



# 2.4 GHz High-Efficiency, High-Gain Power Amplifier Module

## SST12LP14E

### Product Brief

SST12LP14E is a high-efficiency, ultra-compact power amplifier (PA) based on the highly-reliable InGaP/GaAs HBT technology. Designed to operate over the 2.4 - 2.5 GHz frequency band, SST12LP14E typically provides 23.5 dB gain with 33% power-added efficiency at 22 dBm output. This power amplifier has excellent linearity while meeting 802.11g spectrum mask requirements up to 22 dBm. The device typically consumes only 95 mA total current at 18 dBm output power, with linear 54 Mbps 802.11g modulation. This efficiency is desirable in embedded applications such as in hand-held units. The SST12LP14E also features easy, board-level usage along with high-speed power-up/-down control through a single combined reference voltage pin and is offered in both 6- and 8-contact XSON packages.

## Features

- **Excellent RF Stability with Moderate Gain:**
  - Typically 23.5 dB gain across 2.4 – 2.5 GHz
- **High Linear Output Power (at 3.3V):**
  - Meets 802.11g OFDM ACPR requirement up to 22 dBm
  - ~2.5% added EVM up to 18 dBm for 54 Mbps 802.11g signal
  - Meets 802.11b ACPR requirement up to 22 dBm
- **High Power-added Efficiency/Low Operating Current for 802.11b/g/n Applications**
  - ~33% @  $P_{OUT} = 22$  dBm for 802.11g
- **Limited variation over temperature**
  - 2.5 dB gain variation between -40°C to +85°C
  - 1 dB power variation between -40°C to +85°C
- **Low Shut-down Current: <2.5  $\mu$ A (typical)**
- **Temperature and load insensitive on-chip power detector**
  - >15dB dynamic range
  - <+/- 0.3dB variation between 0°C to +85°C
  - <+/- 0.4dB variation with 2:1 VSWR mismatch
  - <+/- 0.3dB variation Ch1 through Ch14
- **Simple input/output matching**
- **Packages Available**
  - 6-contact XSON – 1.5mm x 1.5mm
  - 8-contact XSON – 2mm x 2mm
- **All Non-Pb (lead-free) Devices are RoHS Compliant**

## Applications

- **WLAN (IEEE 802.11b/g/n)**
- **Home RF**
- **Cordless phones**
- **2.4 GHz ISM wireless equipment**

## Block Diagram

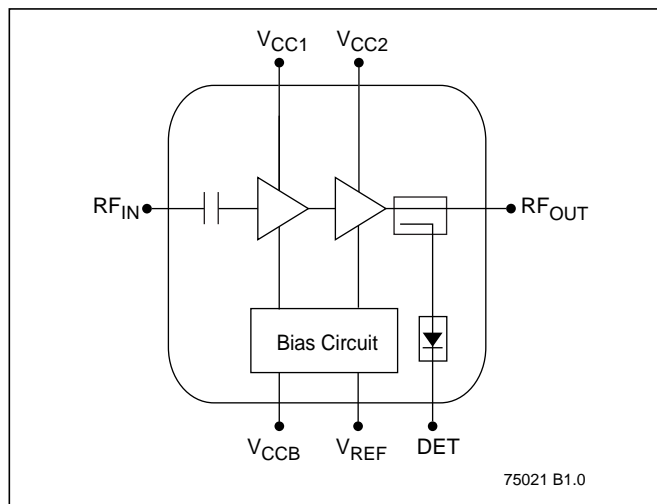

## Product Ordering

### Valid combinations for SST12LP14E

SST12LP14E-QX8E    SST12LP14E-QX6E

### SST12LP14E Evaluation Kits

SST12LP14E-QX8E-K    SST12LP14E-QX6E-K

**Note:** Valid combinations are those products in mass production or will be in mass production. Consult your SST sales representative to confirm availability of valid combinations and to determine availability of new combinations.



A Microchip Technology Company

# 2.4 GHz High-Efficiency, High-Gain Power Amplifier Module SST12LP14E

Product Brief

## Contact Information

Thank you for your interest in Microchip RF products. The data sheet for this device contains proprietary information. To obtain a copy of the data sheet, contact your local Microchip sales representative or distributor at the link below.

### Global Sales and Distribution

**Table 1:**Revision History

Revision	Description	Date
A	• Initial release of Product Brief	Mar 2012

ISBN:978-162076-085-7

© 2012 Silicon Storage Technology, Inc—a Microchip Technology Company. All rights reserved.

SST, Silicon Storage Technology, the SST logo, SuperFlash, MTP, and FlashFlex are registered trademarks of Silicon Storage Technology, Inc. MPF, SQI, Serial Quad I/O, and Z-Scale are trademarks of Silicon Storage Technology, Inc. All other trademarks and registered trademarks mentioned herein are the property of their respective owners.

Specifications are subject to change without notice. Refer to [www.microchip.com](http://www.microchip.com) for the most recent documentation. For the most current package drawings, please see the Packaging Specification located at <http://www.microchip.com/packaging>.

Memory sizes denote raw storage capacity; actual usable capacity may be less.

SST makes no warranty for the use of its products other than those expressly contained in the Standard Terms and Conditions of Sale.

For sales office locations and information, please see [www.microchip.com](http://www.microchip.com).

---

Silicon Storage Technology, Inc.  
A Microchip Technology Company  
[www.microchip.com](http://www.microchip.com)

---

## Looking for pricing, stock, or lifecycle information?

Click below to explore more details on WIN SOURCE:

- ⊖ [View SST12LP14E-QX6E on WIN SOURCE](#)
- ⊖ [Microchip Technology](#) Information

## Optimize Your Supply Chain with WIN SOURCE Solutions

- ✓ Global Sourcing Solution
- ✓ Obsolete Management
- ✓ Cost Control Management
- ✓ Shortage Management
- ✓ Alternative Solution
- ✓ Excess Inventory Management