



2.4 GHz High-Power, High-Gain Power Amplifier

SST12LP07A

Product Brief

The SST12LP07A is a versatile power amplifier based on the highly-reliable InGaP/GaAs HBT technology. It is easily configured for high-power applications with excellent (30.8%) power-added efficiency, operating over the 2.4- 2.5 GHz frequency band and meeting 802.11 b/g spectrum mask at 23.5 dBm. The SST12LP07A has excellent linearity, typically ~2.5% added EVM at 20 dBm output power, which is essential for 54 Mbps 802.g/n operation. The Power Amplifier has an excellent on-chip, single-ended power detector, providing a reliable solution to board-level power control. The SST12LP07A is offered in a 12-contact XQFN package.

Features

- **High Gain:**
 - Typically 28 dB gain across 2.4–2.5 GHz over temperature 0°C to +85°C
- **High linear output power (at 3.3V):**
 - >28 dBm P1dB
 - ~2.5% added EVM up to 20 dBm for 54 Mbps 802.11g signal
 - Meets 802.11g OFDM ACPR requirement up to 24 dBm
 - Meets 802.11b ACPR requirement up to 24 dBm
- **High power-added efficiency/Low operating current for both 802.11 b/g applications**
 - ~30.8% @ $P_{OUT} = 23.5$ dBm for both 802.11g and 802.11b
- **Low shut-down current (~2 μ A)**
- **High temperature stability**
 - ~1.5 dB power variation between -40°C to +85°C
 - ~2.5 dB gain variation between -40°C to +85°C
- **Temperature and load insensitive on-chip power detector**
 - 20 dB dynamic range
- **Simple input/output matching**
- **Packages available**
 - 12-contact XQFN – 2mm x 2mm x 0.45mm
- **All devices are RoHS compliant**

Applications

- **WLAN (IEEE 802.11b/g/n)**
- **Home RF**
- **Cordless phones**
- **2.4 GHz ISM wireless equipment**

Block Diagram

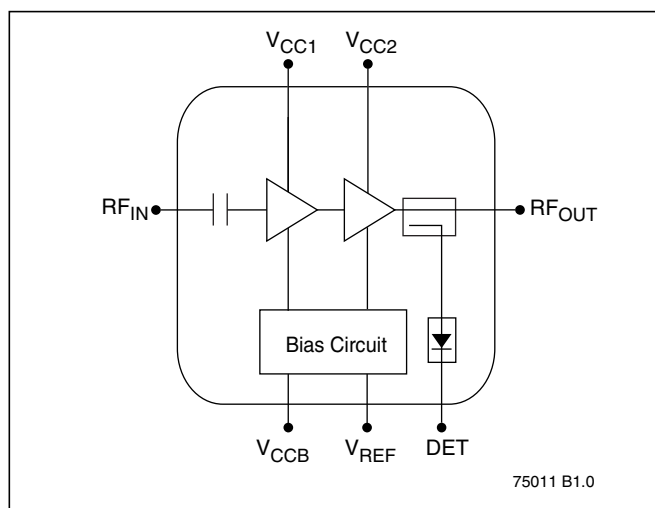

Product Ordering

Valid combinations for SST12LP07A

SST12LP07A-QXBE

SST12LP07A Evaluation Kits

SST12LP07A-QXBE-K

Note: Valid combinations are those products in mass production or will be in mass production. Consult your SST sales representative to confirm availability of valid combinations and to determine availability of new combinations.



A Microchip Technology Company

2.4 GHz High-Power, High-Gain Power Amplifier

SST12LP07A

Product Brief

Contact Information

Thank you for your interest in Microchip RF products. The data sheet for this device contains proprietary information. To obtain a copy of the data sheet, contact your local Microchip sales representative or distributor at the link below.

Global Sales and Distribution

Table 1:Revision History

Revision	Description	Date
A	• Initial release of Product Brief	Oct 2011

ISBN:978-1-61341-736-2

© 2011 Silicon Storage Technology, Inc—a Microchip Technology Company. All rights reserved.

SST, Silicon Storage Technology, the SST logo, SuperFlash, MTP, and FlashFlex are registered trademarks of Silicon Storage Technology, Inc. MPF, SQI, Serial Quad I/O, and Z-Scale are trademarks of Silicon Storage Technology, Inc. All other trademarks and registered trademarks mentioned herein are the property of their respective owners.

Specifications are subject to change without notice. Refer to www.microchip.com for the most recent documentation. For the most current package drawings, please see the Packaging Specification located at <http://www.microchip.com/packaging>.

Memory sizes denote raw storage capacity; actual usable capacity may be less.

SST makes no warranty for the use of its products other than those expressly contained in the Standard Terms and Conditions of Sale.

For sales office locations and information, please see www.microchip.com.

Silicon Storage Technology, Inc.
A Microchip Technology Company
www.microchip.com

Looking for pricing, stock, or lifecycle information?

Click below to explore more details on WIN SOURCE:

 [View SST12LP07A-QXBE on WIN SOURCE](#)

 [Microchip Technology](#) Information

Optimize Your Supply Chain with WIN SOURCE Solutions

-  Global Sourcing Solution
-  Obsolete Management
-  Cost Control Management
-  Shortage Management
-  Alternative Solution
-  Excess Inventory Management