



*SST11LP12 is a high-power, high-gain power amplifier based on the highly-reliable InGaP/GaAs HBT technology. It is configured for high-power, high-efficiency applications with high power-added efficiency while operating over the entire 802.11a frequency band for U.S., European, and Japanese markets (4.9-5.9 GHz). The power amplifier IC features easy board-level usage along with high-speed power-up/down control and is offered in a 16-contact WQFN package*

## Features

- **High gain**
- **High linear output power:**
  - Meets 802.11a OFDM Spectrum Mask requirements up to 24 dBm over the entire band
  - Added EVM <3% up to 20 dBm for 54 Mbps 802.11a signal
  - Meets 802.11n HT40 Spectrum Mask requirements typically up to 20 dBm
- **High power-added efficiency/Low operating current for 6 Mbps 802.11a applications**
  - ~17% @  $P_{OUT} = 23$  dBm for 6 Mbps
- **Built-in Ultra-low  $I_{REF}$  power-up/down control**
  - $I_{REF} < 3$  mA
- **Low idle current**
  - ~150 mA  $I_{CQ}$
- **High speed power up/down**
  - Turn on/off time (10%~90%) <100 ns
  - Typical power-up/down delay with driver delay included <200 ns
- **High temperature stability**
- **Low shut-down current (~2  $\mu$ A)**
- **On-chip power detection**
- **20 dB dynamic range on-chip power detection**
- **Simple input/output matching**
- **Packages available**
  - 16-contact WQFN (3mm x 3mm)
  - Non-Pb (lead-free) packages available

## Applications

- **WLAN (IEEE 802.11a/n)**
- **Japan WLAN**
- **HyperLAN2**
- **Multimedia**



# 4.9-5.9 GHz High-Linearity Power Amplifier

## SST11LP12

### Product Description

SST11LP12 is a high-power, high-gain power amplifier based on the highly-reliable InGaP/GaAs HBT technology.

The SST11LP12 can be easily configured for high-power, high-efficiency applications with superb power-added efficiency while operating over the entire 802.11a frequency band for U.S., European, and Japanese markets (4.9-5.9 GHz).

The SST11LP12 has excellent linearity, typically <3% added EVM at 20 dBm output power which is essential for 54 Mbps 802.11a operation while meeting 802.11a spectrum mask at 24 dBm. SST11LP12 also has wide-range (>20 dB), temperature-stable (~1 dB over 85°C), single-ended/differential power detectors which lower users' cost on power control.

The power amplifier IC also features easy board-level usage along with high-speed power-up/down control. Ultra-low reference current (total  $I_{REF} < 3$  mA) makes the SST11LP12 controllable by an on/off switching signal directly from the baseband chip. These features coupled with low operating current make the SST11LP12 ideal for the final stage power amplification in battery-powered 802.11a WLAN transmitter and access point applications.

The SST11LP12 is offered in 16-contact WQFN package. See Figure 2 for pin assignments and Table 1 for pin descriptions.



### Functional Blocks

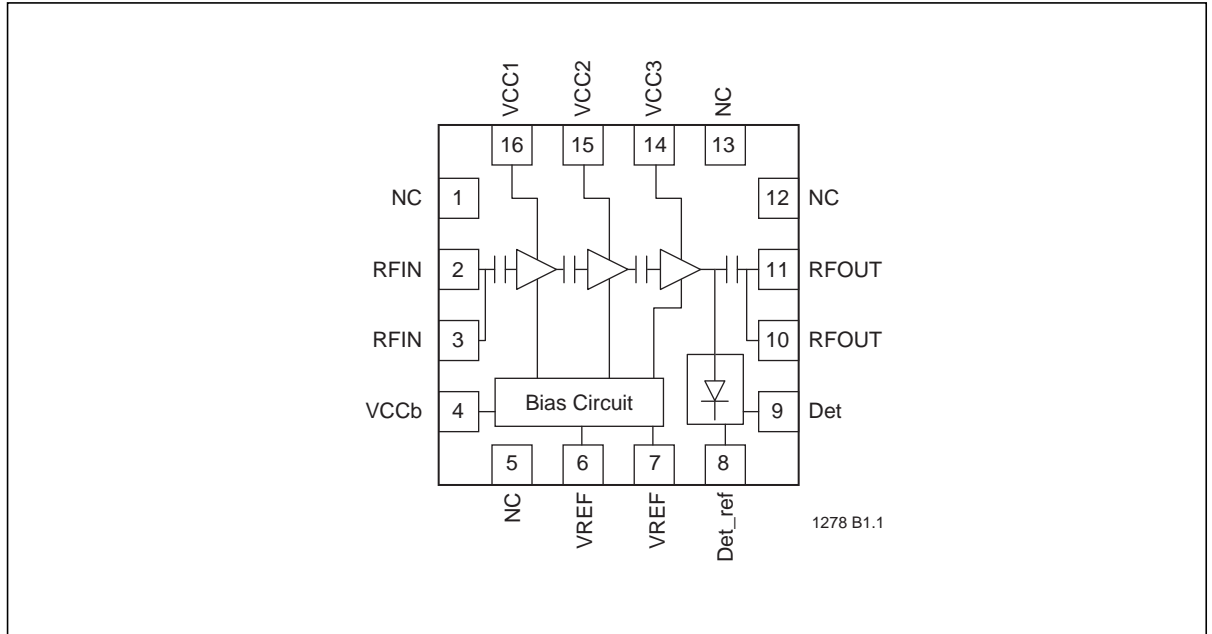

Figure 1: Functional Block Diagram



### Pin Assignments

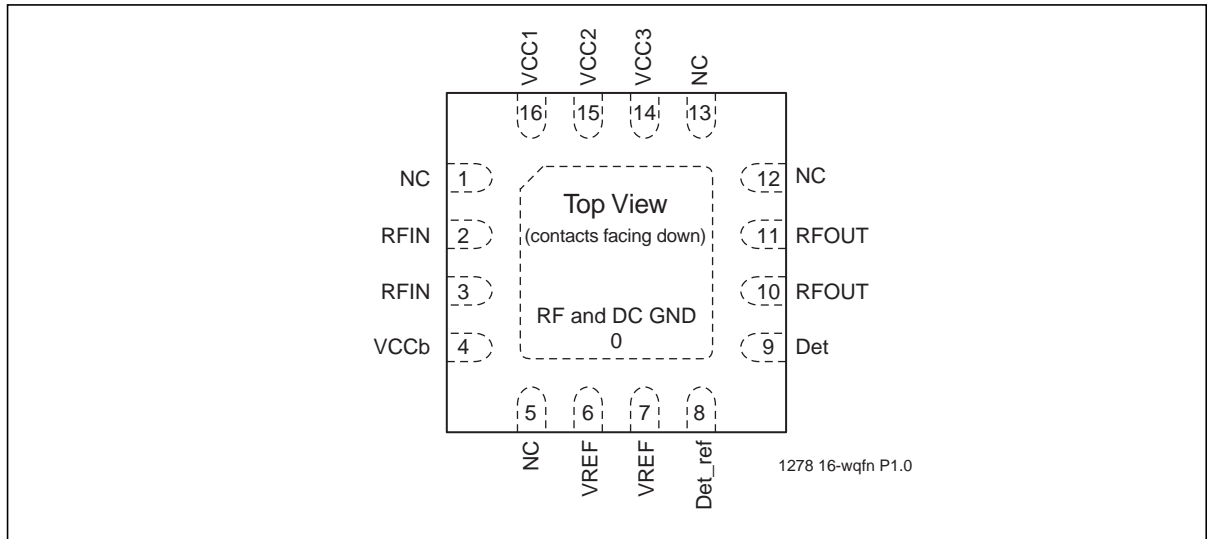

Figure 2: Pin Assignments for 16-contact WQFN

### Pin Descriptions

Table 1: Pin Description

Symbol	Pin No.	Pin Name	Type <sup>1</sup>	Function
GND	0	Ground		The center pad should be connected to RF ground with several low inductance, low resistance vias.
NC	1	No Connection		Unconnected pin
RFIN	2		I	RF input, DC decoupled
RFIN	3		I	RF input, DC decoupled
VCCb	4	Power Supply	PWR	Supply voltage for bias circuit
NC	5	No Connection		Unconnected pin
VREF	6		PWR	Current Control
VREF	7		PWR	Current Control
Det_ref	8		O	On-chip power detector reference
Det	9		O	On-chip power detector
RFOUT	10		O	RF output
RFOUT	11		O	RF output
NC	12	No Connection		Unconnected pin
NC	13	No Connection		Unconnected pin
VCC3	14	Power Supply	PWR	Power supply, 3rd stage
VCC2	15	Power Supply	PWR	Power supply, 2nd stage
VCC1	16	Power Supply	PWR	Power supply, 1st stage

1. I=Input, O=Output



# 4.9-5.9 GHz High-Linearity Power Amplifier SST11LP12

## Electrical Specifications

The AC and DC specifications for the power amplifier interface signals. Refer to Table 3 for the DC voltage and current specifications. Refer to Figures 3 through 8 for the RF performance.

**Absolute Maximum Stress Ratings** (Applied conditions greater than those listed under “Absolute Maximum Stress Ratings” may cause permanent damage to the device. This is a stress rating only and functional operation of the device at these conditions or conditions greater than those defined in the operational sections of this data sheet is not implied. Exposure to absolute maximum stress rating conditions may affect device reliability.)

- Supply Voltage at pins 4, 14, 15, 16 ( $V_{CC}$ ) ..... -0.3V to +4.8V
- DC supply current ( $I_{CC}$ ) ..... 500 mA
- Operating Temperature ( $T_A$ ) ..... -40°C to +85°C
- Storage Temperature ( $T_{STG}$ ) ..... -40°C to +120°C
- Maximum Junction Temperature ( $T_J$ ) ..... +150°C
- Surface Mount Solder Reflow Temperature ..... 260°C for 10 seconds

**Table 2:** Operating Range

Range	Ambient Temp	$V_{CC}$
Industrial	-40°C to +85°C	2.7V to 4.2V

T2.1 75047

**Table 3:** DC Electrical Characteristics

Symbol	Parameter	Min.	Typ	Max.	Unit	Test Conditions
$V_{CC}$	Supply Voltage at pins 4, 14, 15, 16	2.7	3.3	4.2	V	
$I_{CC}$	Supply Current @ $P_{OUT} = 23$ dBm at $V_{CC} = 3.3V$			400	mA	
$I_{CQ}$	$V_{CC}$ quiescent current		150		mA	
$I_{OFF}$	Shut down current		<1.0		$\mu A$	
$V_{REG}$	Reference Voltage for recommended application		2.95	3.1	V	

T3.0 75047



# 4.9-5.9 GHz High-Linearity Power Amplifier

## SST11LP12

Data Sheet

**Table 4:** AC Electrical Characteristics for Configuration<sup>1,2</sup>

Symbol	Parameter	Min	Typ	Max	Unit
F <sub>L-U</sub>	Frequency range	4.9		5.9	GHz
Linearity	Output power with <3% EVM at 54 Mbps OFDM signal when operating at 3.3V V <sub>CC</sub>		20		dBm
	Output power level with 802.11a mask compliance across 4.9-5.8 GHz		23		dBm
	Output power level with 802.11n, HT40 mask compliance across 4.9-5.8 GHz		20		dBm
G	Gain over band (4.9-5.1 MHz)		33		dB
	Gain over band (5.3-5.5 MHz)		31		dB
	Gain over band (5.7-5.8 MHz)		27		dB
Det	Power detector output voltage range	0.5		2.0	V
Det_ref	Power detector output reference	0.5	0.6		V
2f, 3f, 4f, 5f	Harmonics at 22 dBm, without trapping capacitors		-50		dBc

T4.1 75047

1. Performance is only valid using the recommended schematic. V<sub>CC</sub> = 3.3V, V<sub>REG</sub> = 2.95, Temperature = 25°C
2. EVM is measured with Equalizer Channel Estimation set to "sequence only."



### Typical Performance Characteristics

Test Conditions:  $V_{CC} = 3.3V$ ,  $T_A = 25^\circ C$ ,  $V_{REG1,2} = 2.95V$  unless otherwise noted

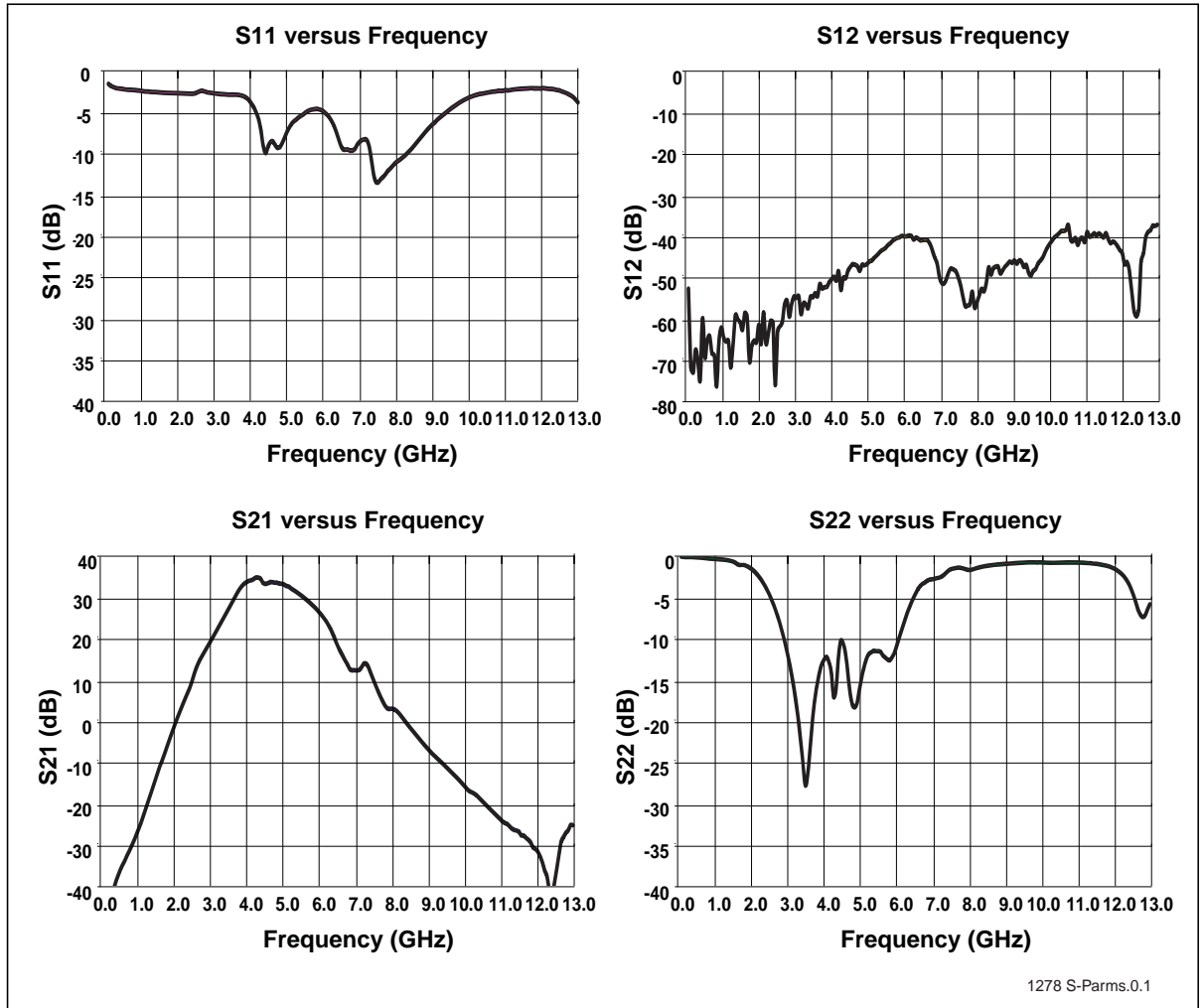

Figure 3: S-Parameters



### Typical Performance Characteristics

Test Conditions:  $V_{CC} = 3.3V$ ,  $T_A = 25^\circ C$ ,  $V_{REG} = 2.95V$  unless otherwise specified  
EVM for 54 Mbps operation

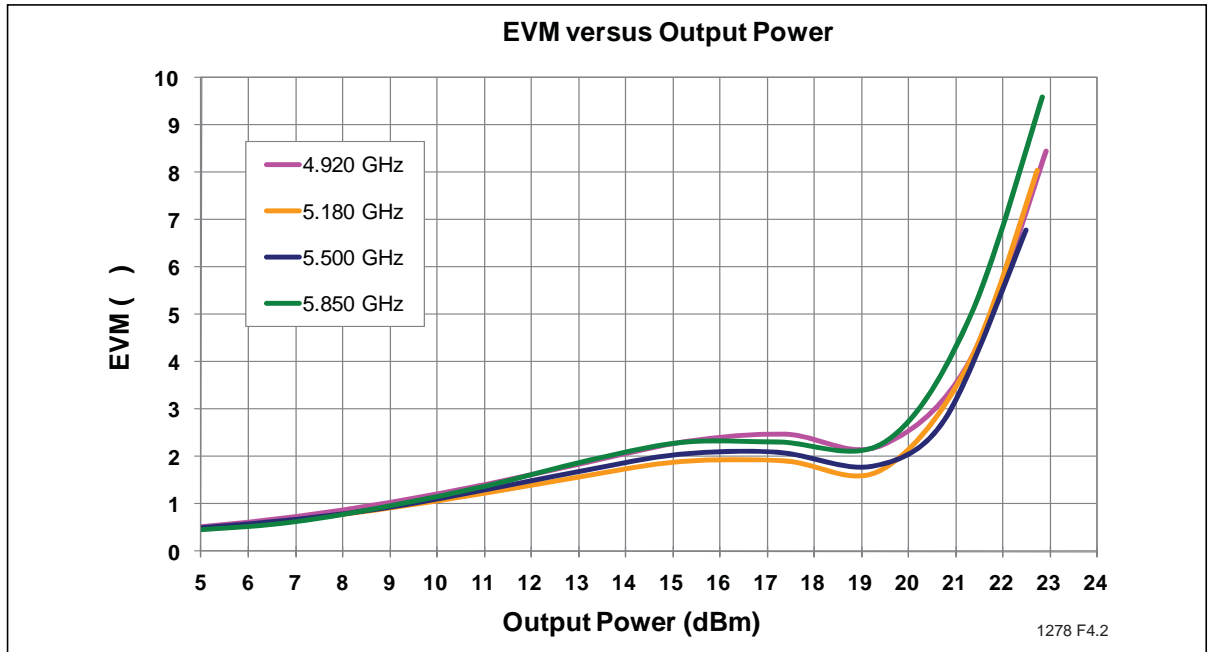

Figure 4: EVM versus Output Power, measured with Equalizer Channel Estimation set to “sequence only”

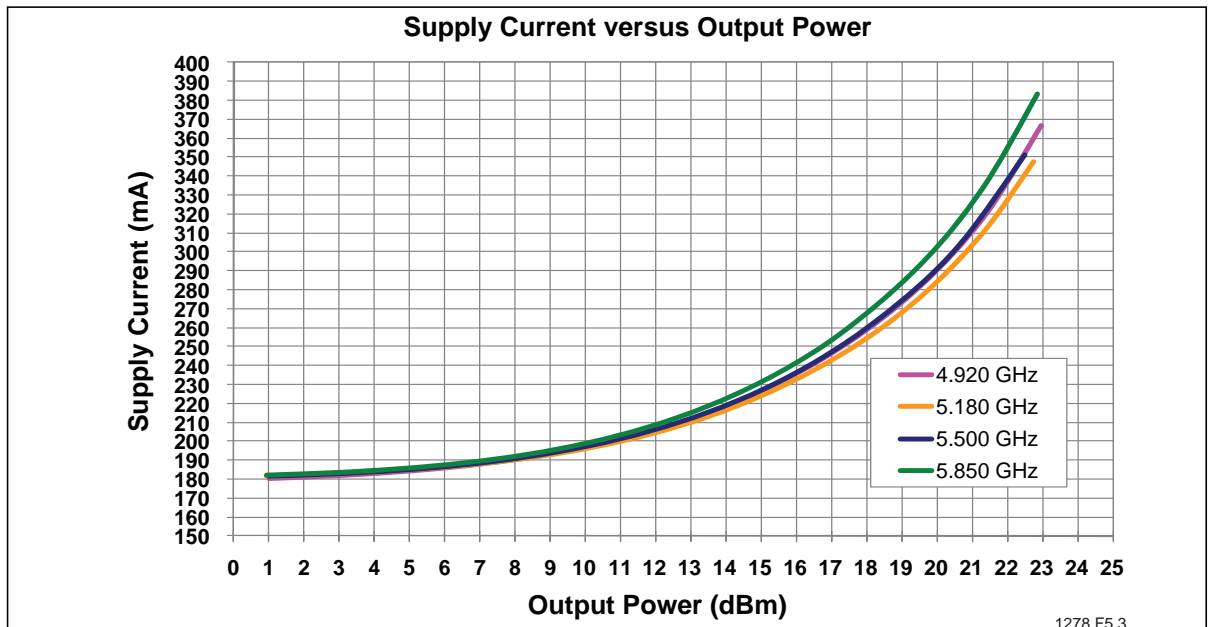

Figure 5: Power Supply Current versus Output Power



# 4.9-5.9 GHz High-Linearity Power Amplifier SST11LP12

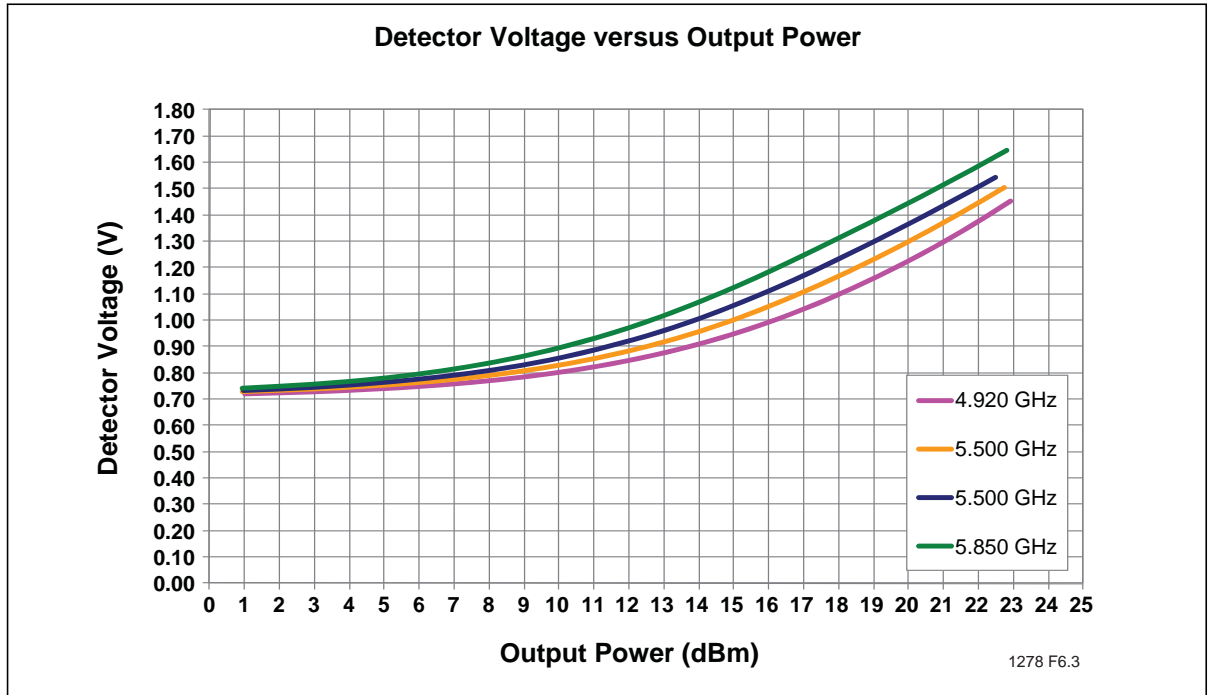

Figure 6: Detector Voltage versus Output Power

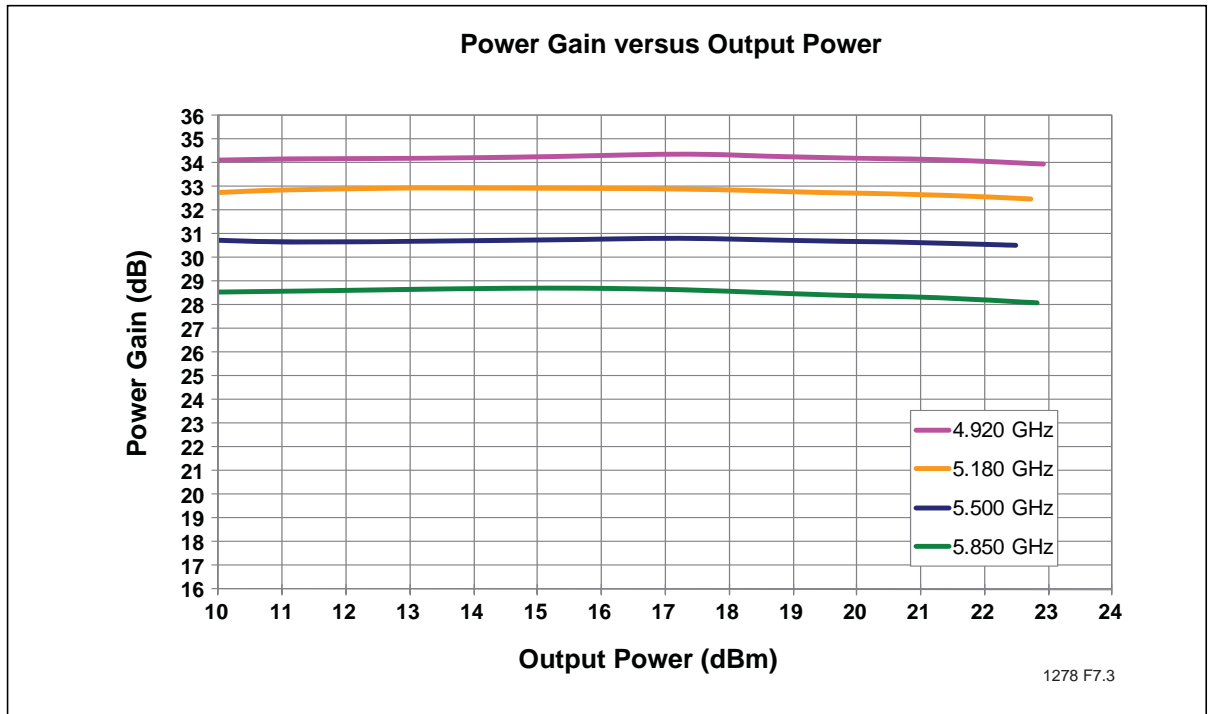
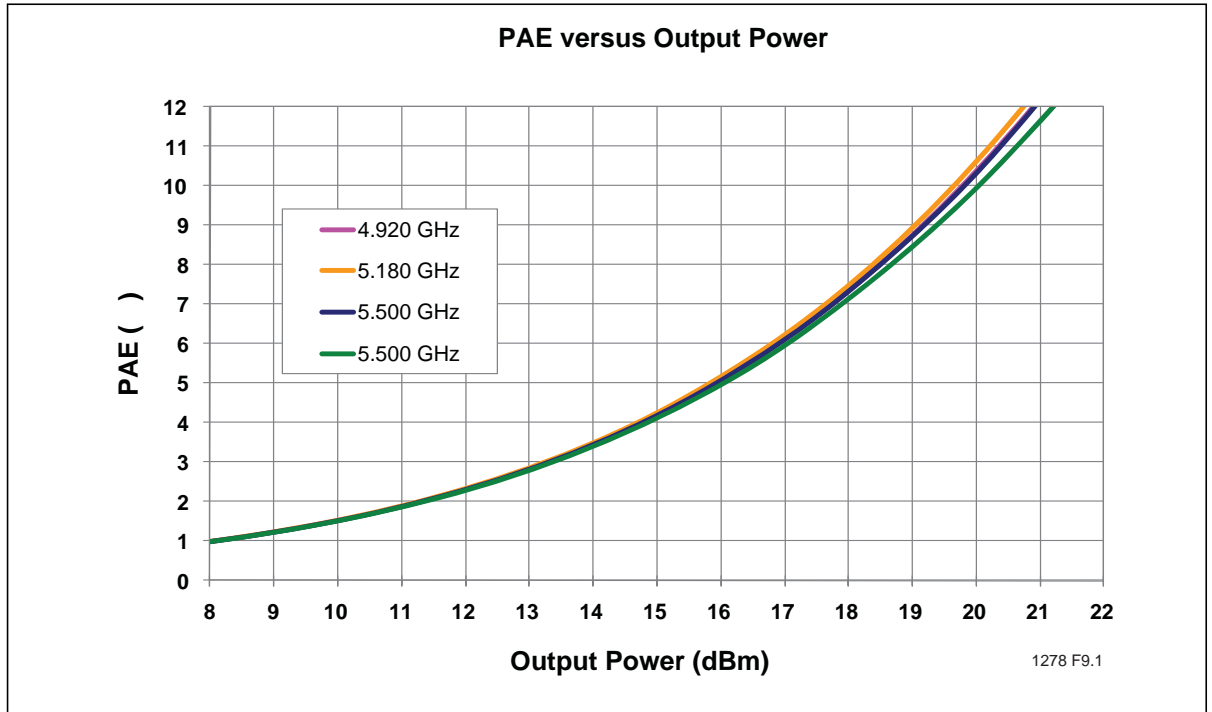

Figure 7: Power Gain versus Output Power



# 4.9-5.9 GHz High-Linearity Power Amplifier SST11LP12



**Figure 8:** PAE versus Output Power

**Table 5:** 802.11a 6Mbps OFDM Mask Compliance Power

Frequency (GHz)	802.11a 6Mbps OFDM Mask Compliance Power (dBm)
4.920	24
5.180	23.8
5.500	23.5
5.805	23

T5.0 75047



# 4.9-5.9 GHz High-Linearity Power Amplifier SST11LP12

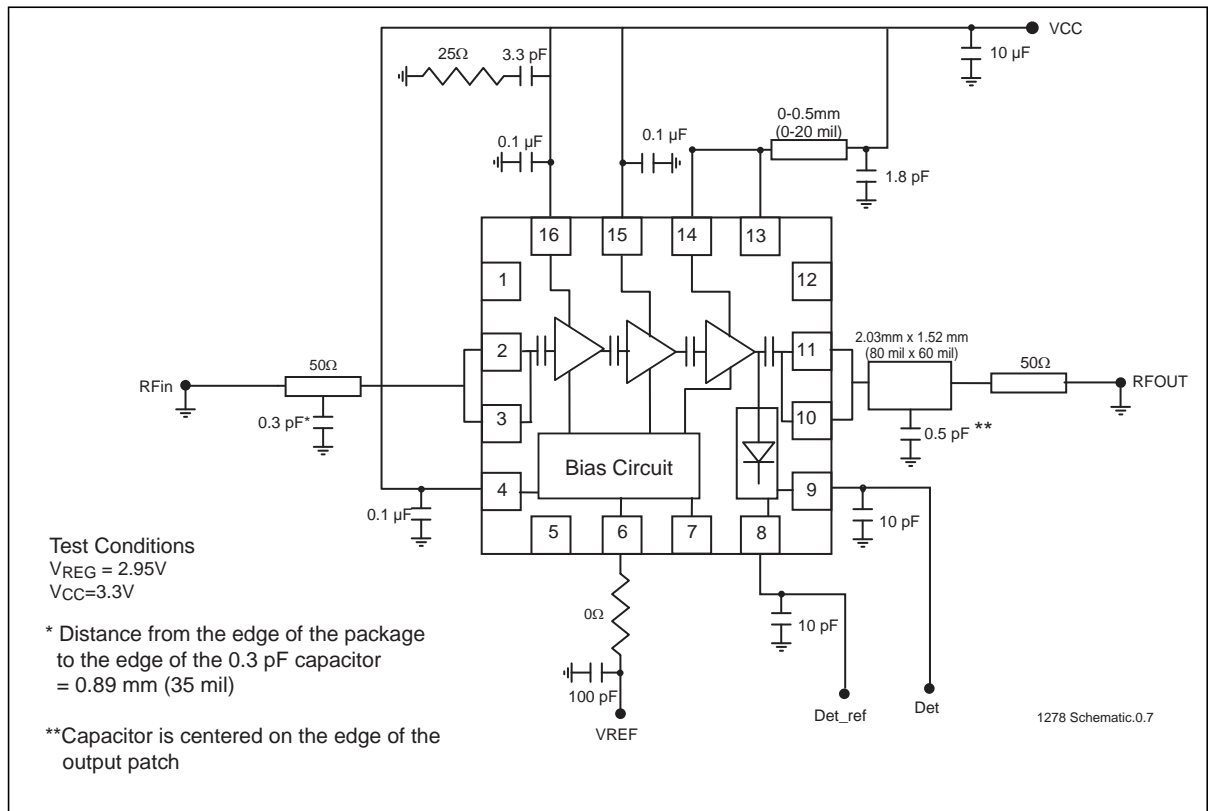

**Figure 9:** Recommended Schematic for High-Power 802.11a Application



### Product Ordering Information

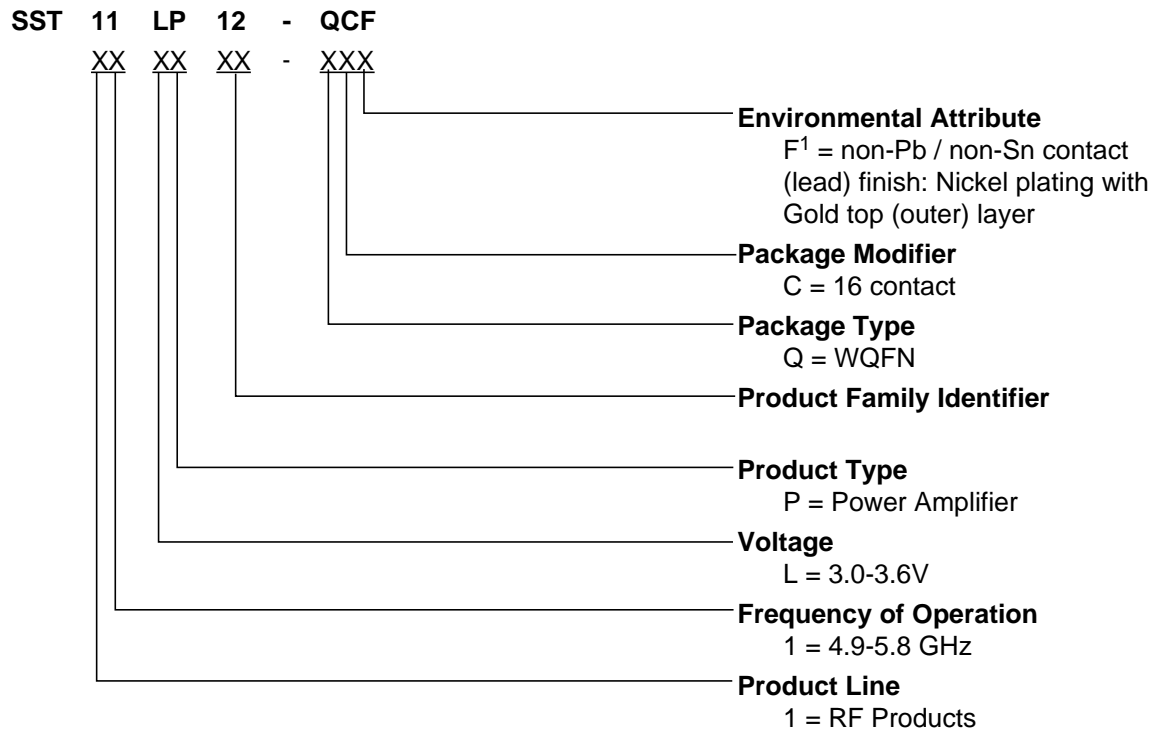

---

1. Environmental suffix "F" denotes non-Pb/non-Sn solder. SST non-Pb/non-Sn solder devices are "RoHS Compliant".

### Valid combinations for SST11LP12

SST11LP12-QCF

### SST11LP12 Evaluation Kits

SST11LP12-QCF-K

**Note:** Valid combinations are those products in mass production or will be in mass production. Consult your SST sales representative to confirm availability of valid combinations and to determine availability of new combinations.



### Packaging Diagrams

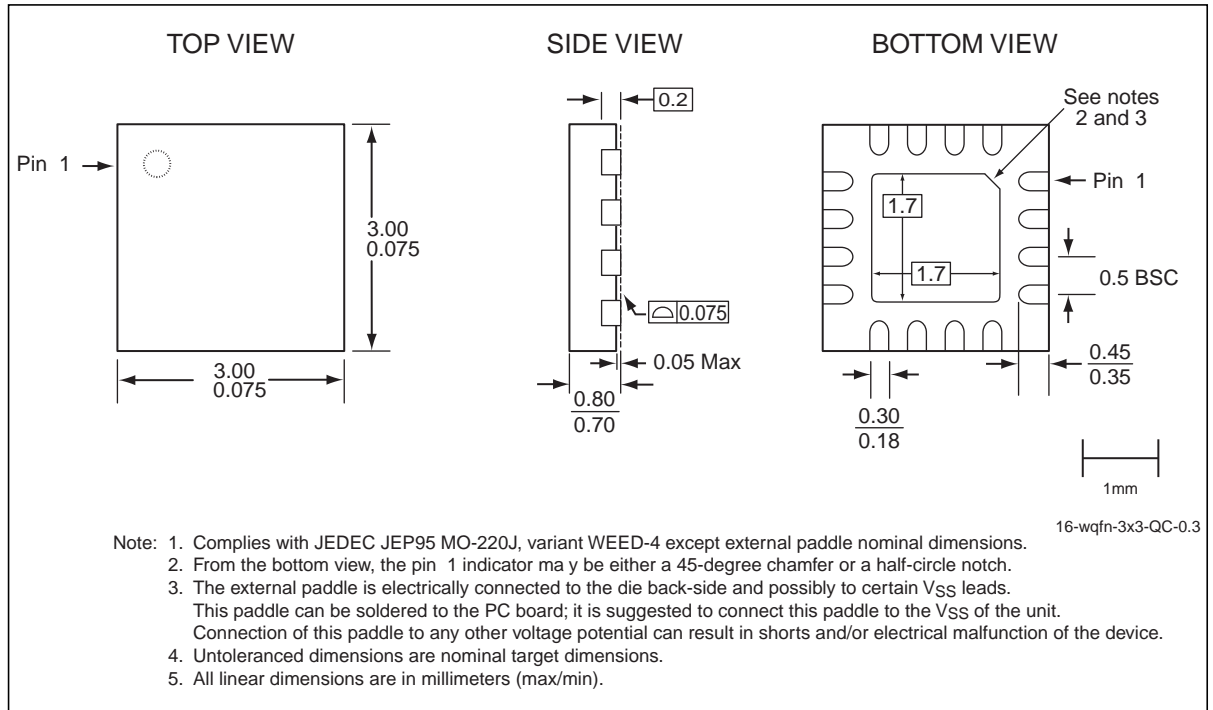

**Figure 10:**16-contact Very-thin Quad Flat No-lead (WQFN)  
SST Package Code: QC



# 4.9-5.9 GHz High-Linearity Power Amplifier SST11LP12

**Table 6:**Revision History

Revision	Description	Date
00	<ul style="list-style-type: none"> <li>S71278: SST conversion of data sheet GP1112</li> </ul>	Jan 2005
01	<ul style="list-style-type: none"> <li>Corrected the spectrum mask value in “Product Description” on page 2 to read 802.11a</li> <li>Corrected the solder reflow temperature under “Absolute Maximum Stress Ratings” on page 5</li> <li>Updated sales and marketing contact information</li> <li>Changed VQFN to WQFN</li> <li>Updated Product Ordering information</li> <li>Updated Table 4 on page 6.</li> </ul>	Jan 2006
02	<ul style="list-style-type: none"> <li>Updated document status from Preliminary Specifications to Data Sheet</li> </ul>	Mar 2008
03	<ul style="list-style-type: none"> <li>Revised gain values in “Features” and “Product Description” on page 2 and in Table 4 on page 6</li> <li>Updated Contact Information</li> </ul>	Feb 2009
04	<ul style="list-style-type: none"> <li>Updated Features, Table 3, Table 4, Table 5, and Figures 4-9 to indicate improved RF performance.</li> </ul>	Dec 2010
A	<ul style="list-style-type: none"> <li>Updated data plots to reflect EVM measurements with Equalizer Channel Estimation set to “sequence only”</li> <li>Updated Table 2 on page 5 and Table 4 on page 6</li> <li>Applied new document format</li> <li>Released document under letter revision system</li> <li>Updated Spec number from S71278 to DS75047</li> </ul>	Jan 2012

ISBN:978-1-61341-948-9

© 2012 Silicon Storage Technology, Inc—a Microchip Technology Company. All rights reserved.

SST, Silicon Storage Technology, the SST logo, SuperFlash, MTP, and FlashFlex are registered trademarks of Silicon Storage Technology, Inc. MPF, SQI, Serial Quad I/O, and Z-Scale are trademarks of Silicon Storage Technology, Inc. All other trademarks and registered trademarks mentioned herein are the property of their respective owners.

Specifications are subject to change without notice. Refer to [www.microchip.com](http://www.microchip.com) for the most recent documentation. For the most current package drawings, please see the Packaging Specification located at <http://www.microchip.com/packaging>.

Memory sizes denote raw storage capacity; actual usable capacity may be less.

SST makes no warranty for the use of its products other than those expressly contained in the Standard Terms and Conditions of Sale.

For sales office locations and information, please see [www.microchip.com](http://www.microchip.com).

---

Silicon Storage Technology, Inc.  
A Microchip Technology Company  
[www.microchip.com](http://www.microchip.com)

---

## Looking for pricing, stock, or lifecycle information?

Click below to explore more details on WIN SOURCE:

- ⊖ [View SST11LP12-QCF on WIN SOURCE](#)
- ⊖ [Microchip Technology Information](#)

## Optimize Your Supply Chain with WIN SOURCE Solutions

- ✓ Global Sourcing Solution
- ✓ Obsolete Management
- ✓ Cost Control Management
- ✓ Shortage Management
- ✓ Alternative Solution
- ✓ Excess Inventory Management