



**THE DATASHEET OF
SSM2377ACBZ-R7**



FEATURES

- Filterless, Class-D amplifier with spread-spectrum Σ - Δ modulation**
- 2.5 W into 4 Ω load and 1.4 W into 8 Ω load at 5.0 V supply with <1% total harmonic distortion plus noise (THD + N)**
- 92% efficiency at 5.0 V, 1.4 W into 8 Ω speaker**
- >100 dB signal-to-noise ratio (SNR)**
- High PSRR at 217 Hz: 80 dB**
- Ultralow EMI emissions**
- Single-supply operation from 2.5 V to 5.5 V**
- Gain select function: 6 dB or 12 dB**
- Fixed input impedance of 80 k Ω**
- 100 nA shutdown current**
- Short-circuit and thermal protection with autorecovery**
- Available in a 9-ball, 1.2 mm \times 1.2 mm WLCSP**
- Pop-and-click suppression**

APPLICATIONS

- Mobile phones**
- MP3 players**
- Portable electronics**

GENERAL DESCRIPTION

The SSM2377 is a fully integrated, high efficiency, Class-D audio amplifier. It is designed to maximize performance for mobile phone applications. The application circuit requires a minimum of external components and operates from a single 2.5 V to 5.5 V supply. It is capable of delivering 2.5 W of continuous output power with <1% THD + N driving a 4 Ω load from a 5.0 V supply.

The SSM2377 features a high efficiency, low noise modulation scheme that requires no external LC output filters. The modulation operates with high efficiency even at low output power.

The SSM2377 operates with 92% efficiency at 1.4 W into 8 Ω from a 5.0 V supply and has an SNR of >100 dB.

Spread-spectrum pulse density modulation (PDM) is used to provide lower EMI-radiated emissions compared with other Class-D architectures. The inherent randomized nature of spread-spectrum PDM eliminates the clock intermodulation (beating effect) of several amplifiers in close proximity.

The SSM2377 produces ultralow EMI emissions that significantly reduce the radiated emissions at the Class-D outputs, particularly above 100 MHz. The SSM2377 passes FCC Class B radiated emission testing with 50 cm, unshielded speaker cable without any external filtering. The ultralow EMI emissions of the SSM2377 are also helpful for antenna and RF sensitivity problems.

The device is configured for either a 6 dB or a 12 dB gain setting by connecting the GAIN pin to the VDD pin or the GND pin, respectively. Input impedance is a fixed value of 80 k Ω , independent of the gain select operation.

The SSM2377 has a micropower shutdown mode with a typical shutdown current of 100 nA. Shutdown is enabled by applying a logic low to the $\overline{\text{SD}}$ pin.

The device also includes pop-and-click suppression circuitry, which minimizes voltage glitches at the output during turn-on and turn-off, reducing audible noise on activation and deactivation. Built-in input low-pass filtering is also included to suppress out-of-band noise interference to the PDM modulator.

The SSM2377 is specified over the industrial temperature range of -40°C to $+85^{\circ}\text{C}$. It has built-in thermal shutdown and output short-circuit protection. It is available in a halide-free, 9-ball, 0.4 mm pitch, 1.2 mm \times 1.2 mm wafer level chip scale package (WLCSP).

FUNCTIONAL BLOCK DIAGRAM

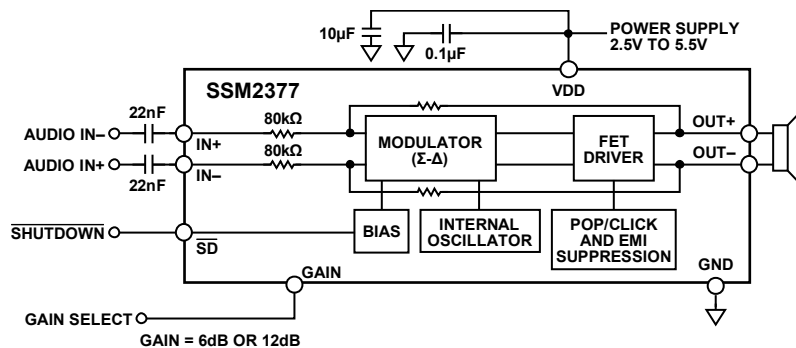

Figure 1.

Rev. 0

Information furnished by Analog Devices is believed to be accurate and reliable. However, no responsibility is assumed by Analog Devices for its use, nor for any infringements of patents or other rights of third parties that may result from its use. Specifications subject to change without notice. No license is granted by implication or otherwise under any patent or patent rights of Analog Devices. Trademarks and registered trademarks are the property of their respective owners.

TABLE OF CONTENTS

Features	1	Theory of Operation	13
Applications.....	1	Overview	13
General Description	1	Gain Selection.....	13
Functional Block Diagram	1	Pop-and-Click Suppression	13
Revision History	2	EMI Noise.....	13
Specifications.....	3	Output Modulation Description	13
Absolute Maximum Ratings.....	5	Layout	14
Thermal Resistance	5	Input Capacitor Selection.....	14
ESD Caution.....	5	Power Supply Decoupling.....	14
Pin Configuration and Function Descriptions.....	6	Outline Dimensions	15
Typical Performance Characteristics	7	Ordering Guide	15
Typical Application Circuits.....	12		

REVISION HISTORY

5/11—Revision 0: Initial Version

SPECIFICATIONS

$V_{DD} = 5.0\text{ V}$, $T_A = 25^\circ\text{C}$, $R_L = 8\ \Omega + 33\ \mu\text{H}$, unless otherwise noted.

Table 1.

Parameter	Symbol	Test Conditions/Comments	Min	Typ	Max	Unit
DEVICE CHARACTERISTICS						
Output Power	P_{OUT}	$f = 1\text{ kHz}$, 20 kHz BW $R_L = 8\ \Omega$, THD = 1%, $V_{DD} = 5.0\text{ V}$ $R_L = 8\ \Omega$, THD = 1%, $V_{DD} = 3.6\text{ V}$ $R_L = 8\ \Omega$, THD = 1%, $V_{DD} = 2.5\text{ V}$ $R_L = 8\ \Omega$, THD = 10%, $V_{DD} = 5.0\text{ V}$ $R_L = 8\ \Omega$, THD = 10%, $V_{DD} = 3.6\text{ V}$ $R_L = 8\ \Omega$, THD = 10%, $V_{DD} = 2.5\text{ V}$ $R_L = 4\ \Omega$, THD = 1%, $V_{DD} = 5.0\text{ V}$ $R_L = 4\ \Omega$, THD = 1%, $V_{DD} = 3.6\text{ V}$ $R_L = 4\ \Omega$, THD = 1%, $V_{DD} = 2.5\text{ V}$ $R_L = 4\ \Omega$, THD = 10%, $V_{DD} = 5.0\text{ V}$ $R_L = 4\ \Omega$, THD = 10%, $V_{DD} = 3.6\text{ V}$ $R_L = 4\ \Omega$, THD = 10%, $V_{DD} = 2.5\text{ V}$		1.41 0.72 0.33 1.78 0.90 0.41 2.49 1.25 0.54 3.17 ¹ 1.56 0.68		W W W W W W W W W W W W
Efficiency	η	$P_{OUT} = 1.4\text{ W}$ into $8\ \Omega$, $V_{DD} = 5.0\text{ V}$		92.4		%
Total Harmonic Distortion Plus Noise	THD + N	$P_{OUT} = 1\text{ W}$ into $8\ \Omega$, $f = 1\text{ kHz}$, $V_{DD} = 5.0\text{ V}$		0.007		%
Input Common-Mode Voltage Range	V_{CM}	$P_{OUT} = 0.5\text{ W}$ into $8\ \Omega$, $f = 1\text{ kHz}$, $V_{DD} = 3.6\text{ V}$	1.0	0.009	$V_{DD} - 1$	V
Common-Mode Rejection Ratio	CMRR	100 mV rms at 1 kHz		51		dB
Average Switching Frequency	f_{SW}			256		kHz
Clock Frequency	f_{OSC}			6.2		MHz
Differential Output Offset Voltage	V_{OOS}	Gain = 6 dB		0.4	5.0	mV
POWER SUPPLY						
Supply Voltage Range	V_{DD}	Guaranteed from PSRR test	2.5		5.5	V
Power Supply Rejection Ratio	$PSRR_{GSM}$	Inputs are ac-grounded, $C_{IN} = 0.1\ \mu\text{F}$, gain = 6 dB $V_{RIPPLE} = 100\text{ mV}$ at 217 Hz		80		dB
	PSRR	$V_{RIPPLE} = 100\text{ mV}$ at 1 kHz		80		dB
Supply Current	I_{SY}	$V_{IN} = 0\text{ V}$, no load, $V_{DD} = 5.0\text{ V}$ $V_{IN} = 0\text{ V}$, no load, $V_{DD} = 3.6\text{ V}$ $V_{IN} = 0\text{ V}$, no load, $V_{DD} = 2.5\text{ V}$ $V_{IN} = 0\text{ V}$, $R_L = 8\ \Omega + 33\ \mu\text{H}$, $V_{DD} = 5.0\text{ V}$ $V_{IN} = 0\text{ V}$, $R_L = 8\ \Omega + 33\ \mu\text{H}$, $V_{DD} = 3.6\text{ V}$ $V_{IN} = 0\text{ V}$, $R_L = 8\ \Omega + 33\ \mu\text{H}$, $V_{DD} = 2.5\text{ V}$		2.5 2.0 1.9 2.5 2.0 1.8		mA mA mA mA mA mA
Shutdown Current	I_{SD}	$\overline{SD} = \text{GND}$		100		nA
GAIN CONTROL						
Closed-Loop Gain	Gain	GAIN = GND GAIN = V_{DD}		12 6		dB dB
Input Impedance	Z_{IN}	$\overline{SD} = V_{DD}$, gain = 6 dB or 12 dB		80		k Ω
SHUTDOWN CONTROL						
Input Voltage High	V_{IH}		1.35			V
Input Voltage Low	V_{IL}				0.35	V
Turn-On Time	t_{WU}	\overline{SD} rising edge from GND to V_{DD}		12.5		ms
Turn-Off Time	t_{SD}	\overline{SD} falling edge from V_{DD} to GND		5		μs
Output Impedance	Z_{OUT}	$\overline{SD} = \text{GND}$	100			k Ω

SSM2377

Parameter	Symbol	Test Conditions/Comments	Min	Typ	Max	Unit
NOISE PERFORMANCE						
Output Voltage Noise	e_n	f = 20 Hz to 20 kHz, inputs are ac-grounded, gain = 6 dB, A-weighted $V_{DD} = 5.0\text{ V}$ $V_{DD} = 3.6\text{ V}$		30 30		μV μV
Signal-to-Noise Ratio	SNR	$P_{OUT} = 1.4\text{ W}$, $R_L = 8\ \Omega$, A-weighted		101		dB

¹ Although the SSM2377 has good audio quality above 3 W, continuous output power beyond 3 W must be avoided due to device packaging limitations.

ABSOLUTE MAXIMUM RATINGS

Absolute maximum ratings apply at 25°C, unless otherwise noted.

Table 2.

Parameter	Rating
Supply Voltage	6 V
Input Voltage	V _{DD}
Common-Mode Input Voltage	V _{DD}
Storage Temperature Range	–65°C to +150°C
Operating Temperature Range	–40°C to +85°C
Junction Temperature Range	–65°C to +165°C
Lead Temperature (Soldering, 60 sec)	300°C
ESD Susceptibility	4 kV

Stresses above those listed under Absolute Maximum Ratings may cause permanent damage to the device. This is a stress rating only; functional operation of the device at these or any other conditions above those indicated in the operational section of this specification is not implied. Exposure to absolute maximum rating conditions for extended periods may affect device reliability.

THERMAL RESISTANCE

Junction-to-air thermal resistance (θ_{JA}) is specified for the worst-case conditions, that is, a device soldered in a printed circuit board (PCB) for surface-mount packages. θ_{JA} is determined according to JEDEC JESD51-9 on a 4-layer PCB with natural convection cooling.

Table 3. Thermal Resistance

Package Type	PCB	θ_{JA}	Unit
9-Ball, 1.2 mm × 1.2 mm WLCSP	2S2P	88	°C/W

ESD CAUTION



ESD (electrostatic discharge) sensitive device. Charged devices and circuit boards can discharge without detection. Although this product features patented or proprietary protection circuitry, damage may occur on devices subjected to high energy ESD. Therefore, proper ESD precautions should be taken to avoid performance degradation or loss of functionality.

PIN CONFIGURATION AND FUNCTION DESCRIPTIONS

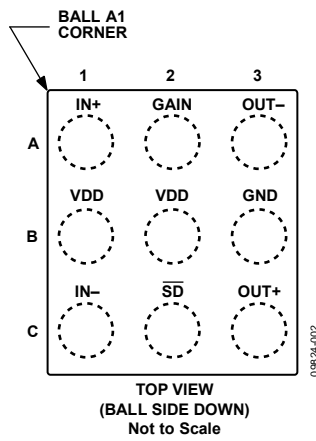

Figure 2. Pin Configuration

Table 4. Pin Function Descriptions

Pin No.	Mnemonic	Description
A1	IN+	Noninverting Input.
B1	VDD	Power Supply.
C1	IN-	Inverting Input.
A2	GAIN	Gain Selection Pin.
B2	VDD	Power Supply.
C2	\overline{SD}	Shutdown Input. Active low digital input.
A3	OUT-	Inverting Output.
B3	GND	Ground.
C3	OUT+	Noninverting Output.

TYPICAL PERFORMANCE CHARACTERISTICS

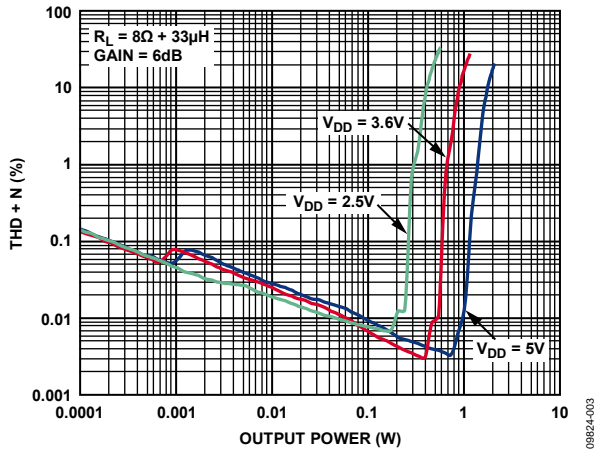

Figure 3. THD + N vs. Output Power into 8 Ω, Gain = 6 dB

09824-003

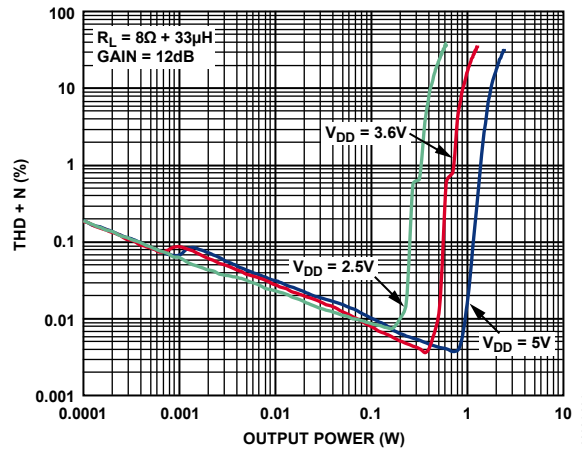

Figure 6. THD + N vs. Output Power into 8 Ω, Gain = 12 dB

09824-004

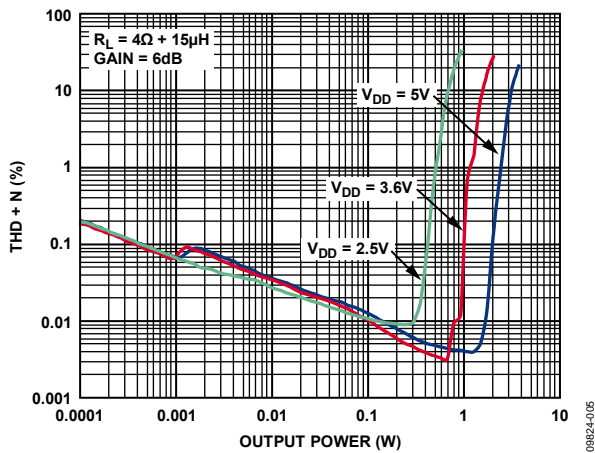

Figure 4. THD + N vs. Output Power into 4 Ω, Gain = 6 dB

09824-005

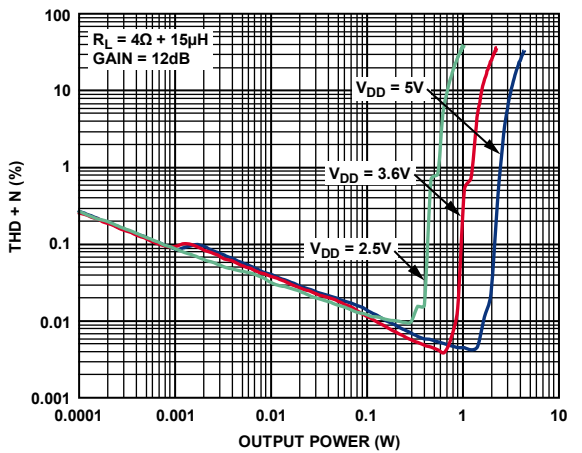

Figure 7. THD + N vs. Output Power into 4 Ω, Gain = 12 dB

09824-006

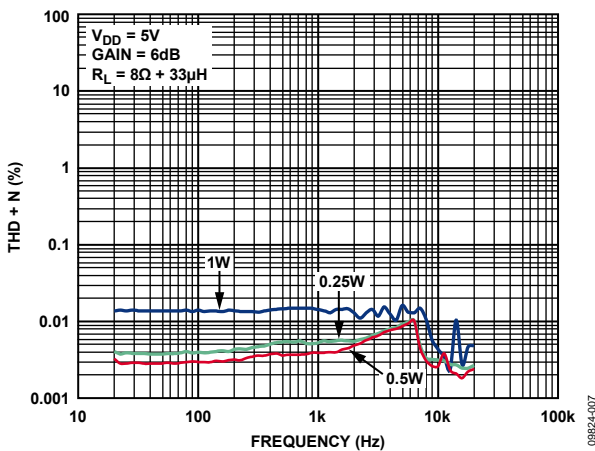

Figure 5. THD + N vs. Frequency, $V_{DD} = 5 V$, $R_L = 8 \Omega$, Gain = 6 dB

09824-007

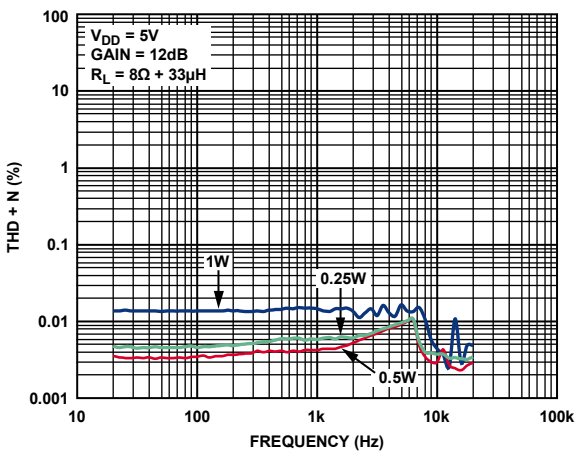

Figure 8. THD + N vs. Frequency, $V_{DD} = 5 V$, $R_L = 8 \Omega$, Gain = 12 dB

09824-008

SSM2377

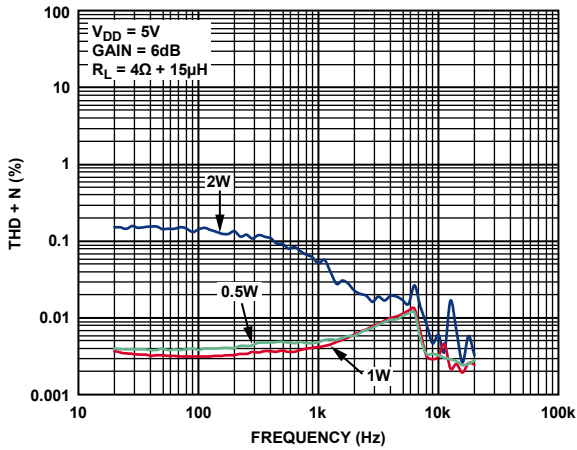

Figure 9. THD + N vs. Frequency, $V_{DD} = 5\text{ V}$, $R_L = 4\ \Omega$, Gain = 6 dB

09824-009

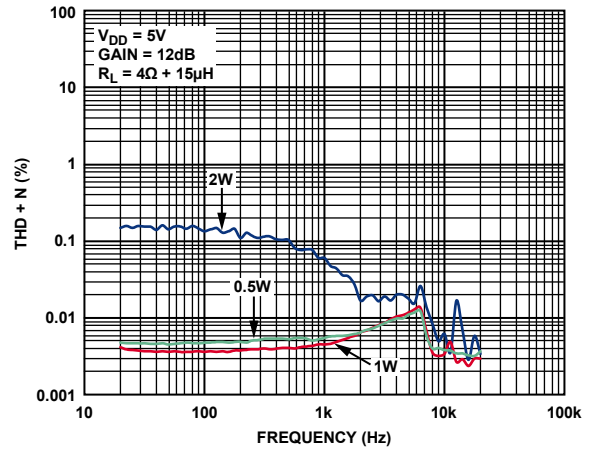

Figure 12. THD + N vs. Frequency, $V_{DD} = 5\text{ V}$, $R_L = 4\ \Omega$, Gain = 12 dB

09824-010

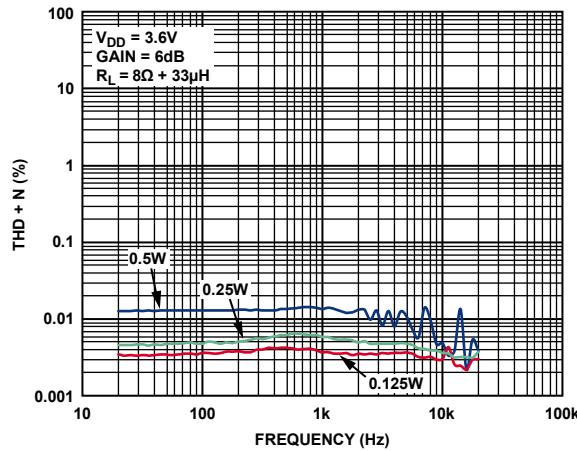

Figure 10. THD + N vs. Frequency, $V_{DD} = 3.6\text{ V}$, $R_L = 8\ \Omega$, Gain = 6 dB

09824-011

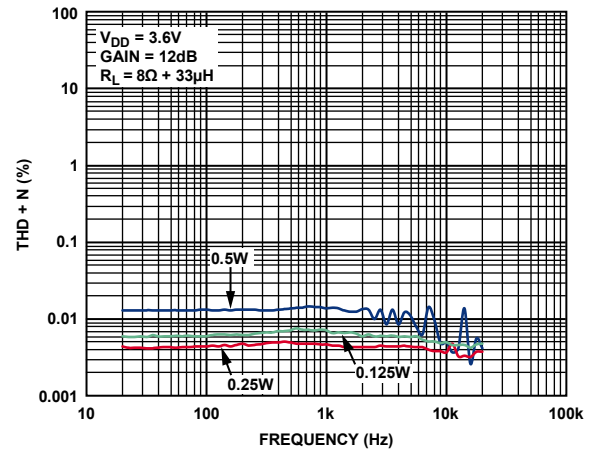

Figure 13. THD + N vs. Frequency, $V_{DD} = 3.6\text{ V}$, $R_L = 8\ \Omega$, Gain = 12 dB

09824-012

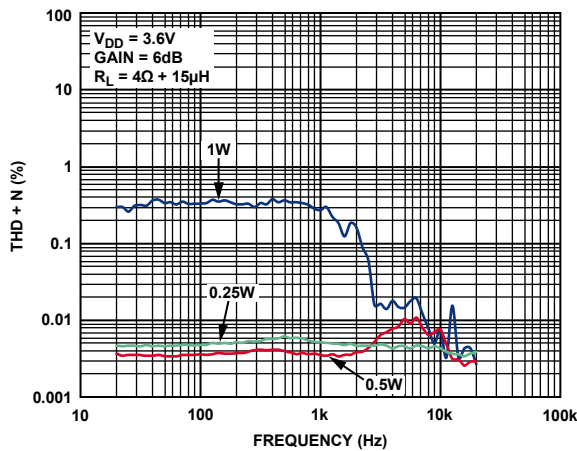

Figure 11. THD + N vs. Frequency, $V_{DD} = 3.6\text{ V}$, $R_L = 4\ \Omega$, Gain = 6 dB

09824-013

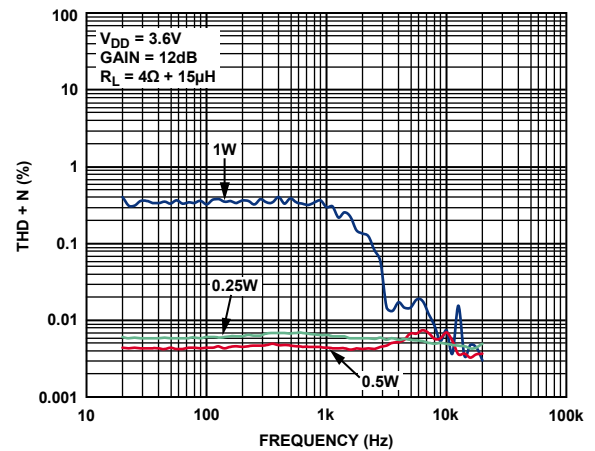

Figure 14. THD + N vs. Frequency, $V_{DD} = 3.6\text{ V}$, $R_L = 4\ \Omega$, Gain = 12 dB

09824-014

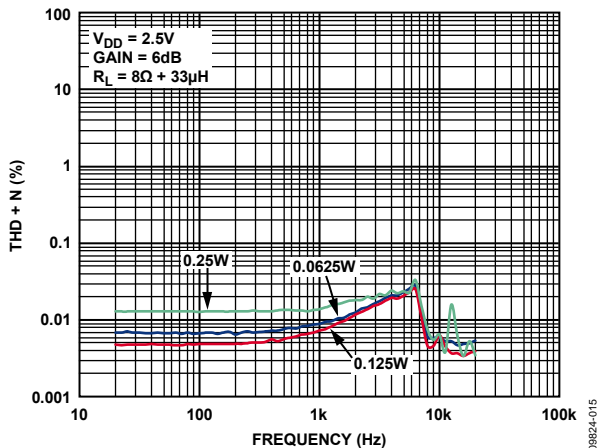

Figure 15. THD + N vs. Frequency, $V_{DD} = 2.5V$, $R_L = 8\Omega$, Gain = 6 dB

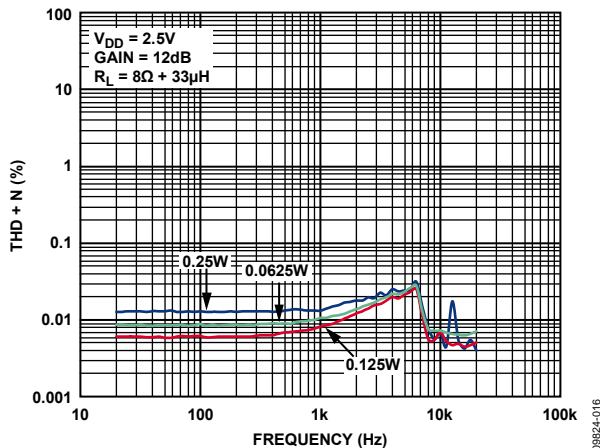

Figure 18. THD + N vs. Frequency, $V_{DD} = 2.5V$, $R_L = 8\Omega$, Gain = 12 dB

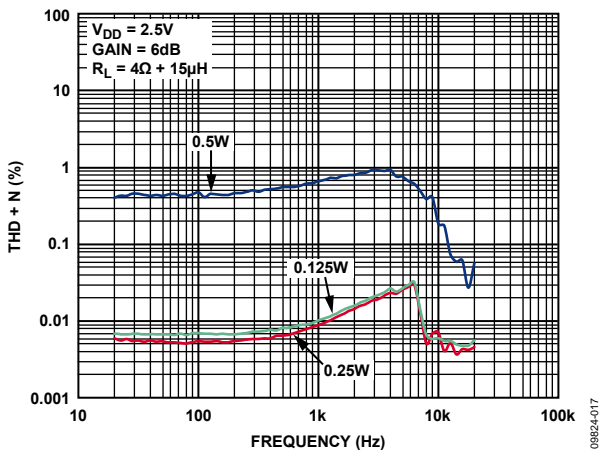

Figure 16. THD + N vs. Frequency, $V_{DD} = 2.5V$, $R_L = 4\Omega$, Gain = 6 dB

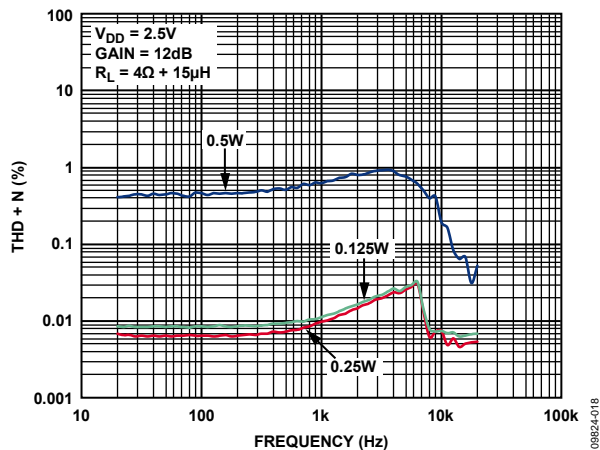

Figure 19. THD + N vs. Frequency, $V_{DD} = 2.5V$, $R_L = 4\Omega$, Gain = 12 dB

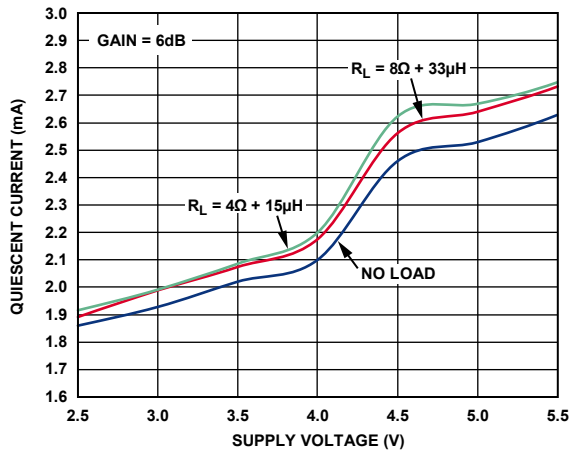

Figure 17. Quiescent Current vs. Supply Voltage, Gain = 6 dB

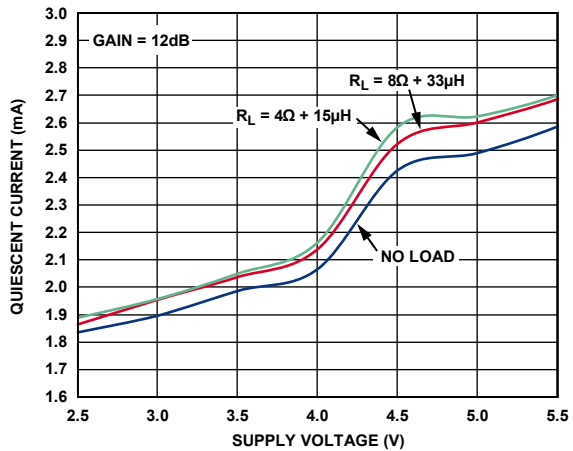

Figure 20. Quiescent Current vs. Supply Voltage, Gain = 12 dB

SSM2377

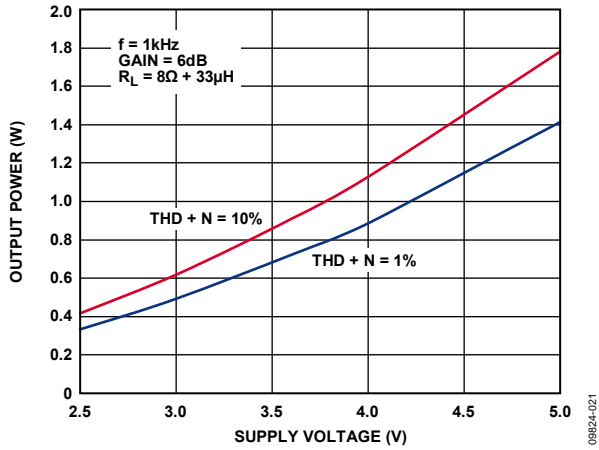

Figure 21. Maximum Output Power vs. Supply Voltage, $R_L = 8 \Omega$, Gain = 6 dB

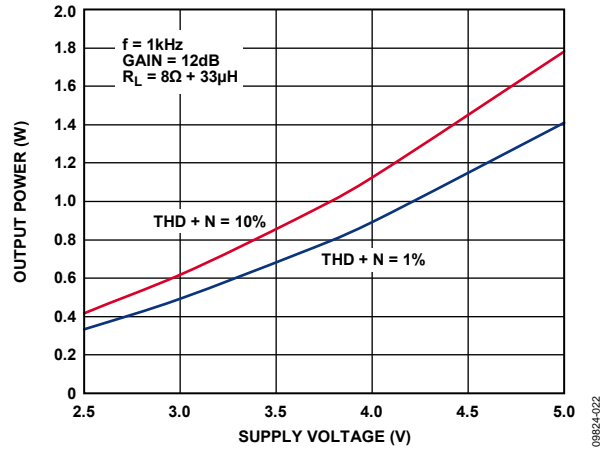

Figure 24. Maximum Output Power vs. Supply Voltage, $R_L = 8 \Omega$, Gain = 12 dB

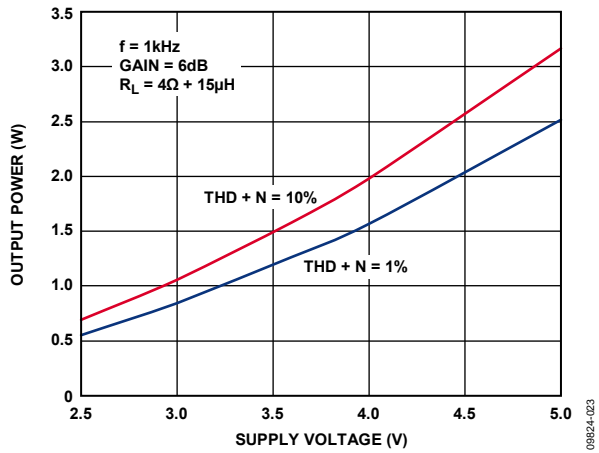

Figure 22. Maximum Output Power vs. Supply Voltage, $R_L = 4 \Omega$, Gain = 6 dB

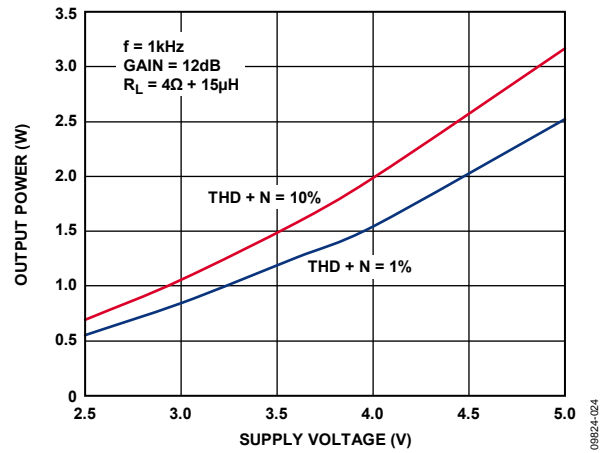

Figure 25. Maximum Output Power vs. Supply Voltage, $R_L = 4 \Omega$, Gain = 12 dB

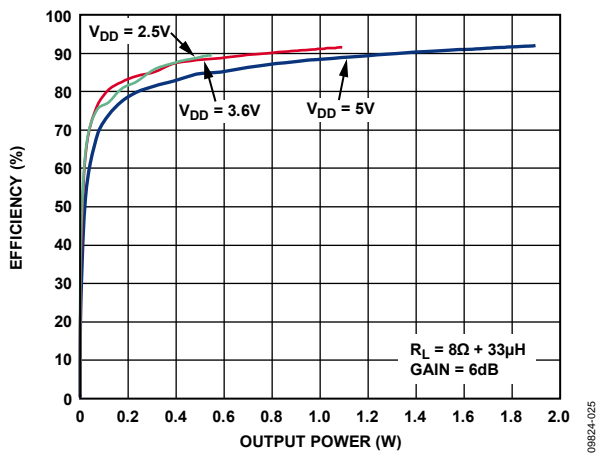

Figure 23. Efficiency vs. Output Power into 8Ω , Gain = 6 dB

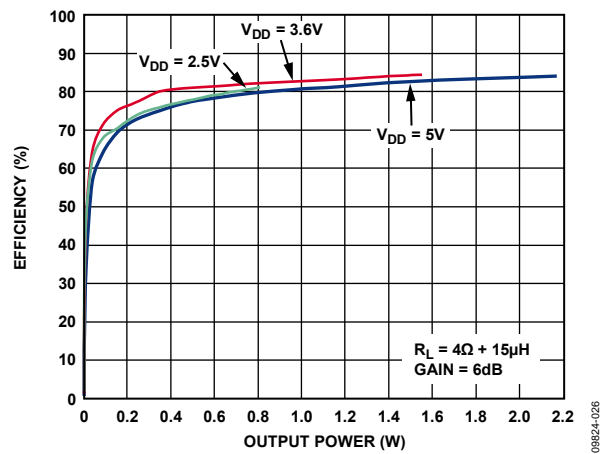

Figure 26. Efficiency vs. Output Power into 4Ω , Gain = 6 dB

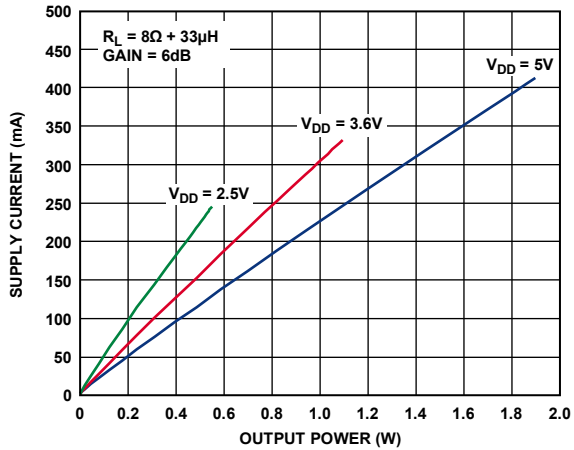

Figure 27. Supply Current vs. Output Power into 8 Ω, Gain = 6 dB

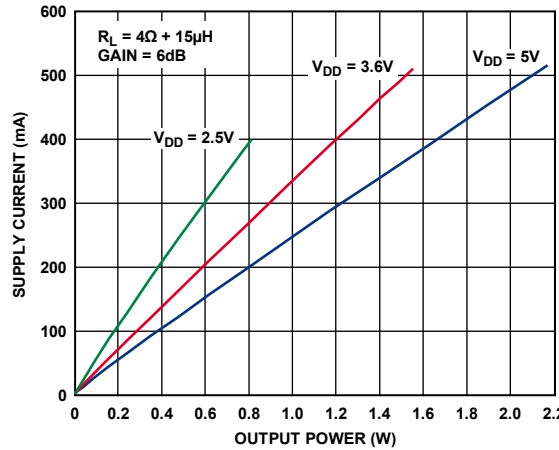

Figure 30. Supply Current vs. Output Power into 4 Ω, Gain = 6 dB

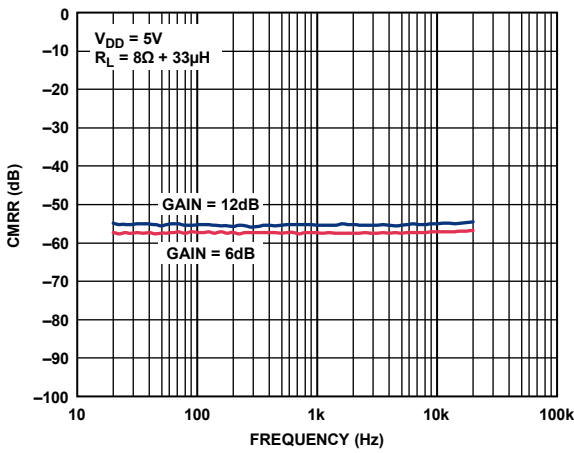

Figure 28. Common-Mode Rejection Ratio (CMRR) vs. Frequency

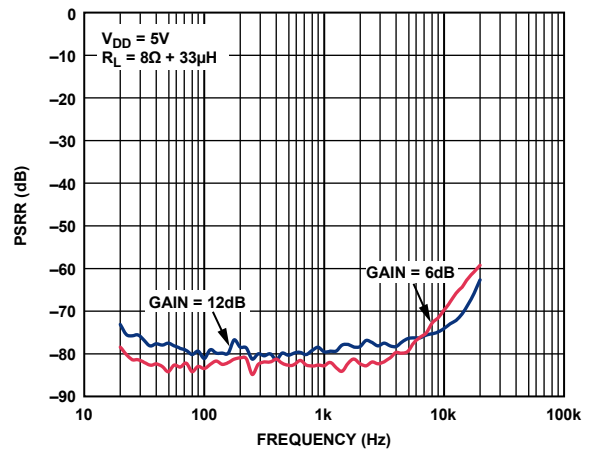

Figure 31. Power Supply Rejection Ratio (PSRR) vs. Frequency

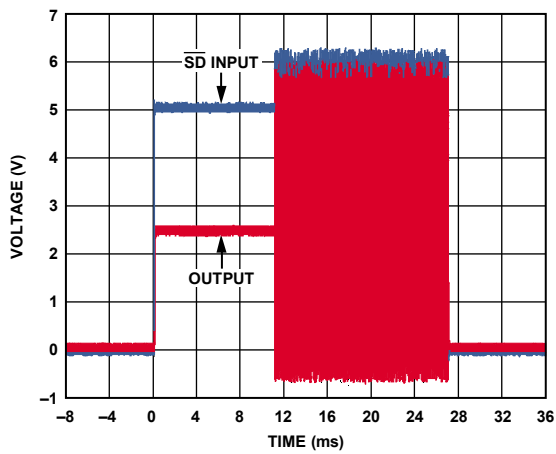

Figure 29. Turn-On Response

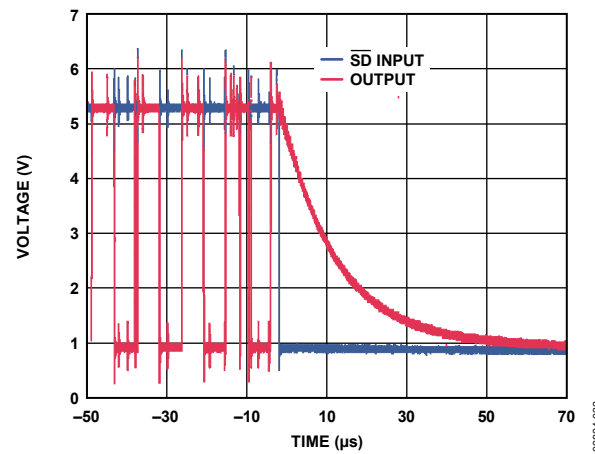

Figure 32. Turn-Off Response

TYPICAL APPLICATION CIRCUITS

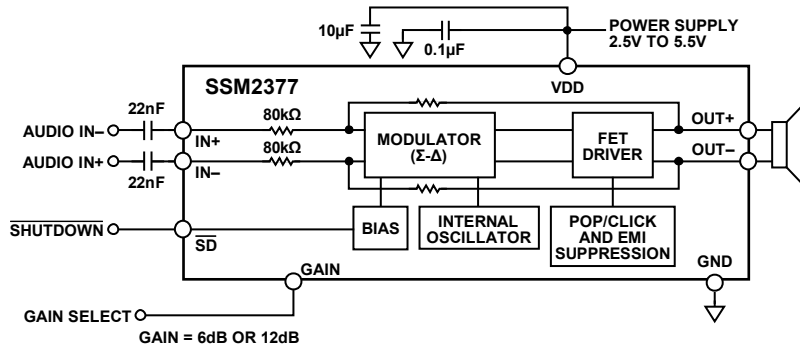

Figure 33. Monaural Differential Input Configuration

09824-033

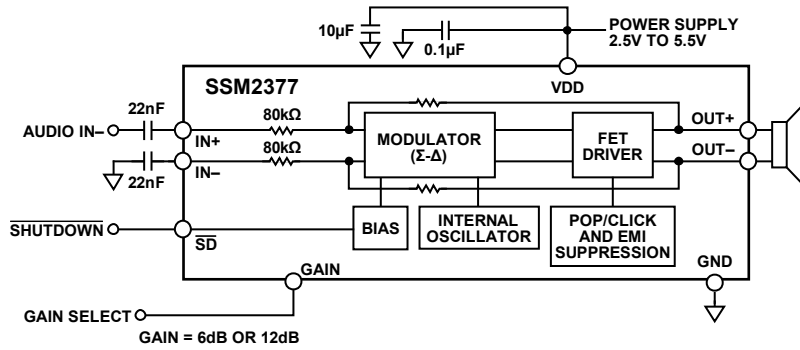

Figure 34. Monaural Single-Ended Input Configuration

09824-034

THEORY OF OPERATION

OVERVIEW

The SSM2377 mono Class-D audio amplifier features a filterless modulation scheme that greatly reduces the external component count, conserving board space and, thus, reducing system cost. The SSM2377 does not require an output filter but, instead, relies on the inherent inductance of the speaker coil and the natural filtering of the speaker and human ear to fully recover the audio component of the square wave output.

Most Class-D amplifiers use some variation of pulse-width modulation (PWM), but the SSM2377 uses Σ - Δ modulation to determine the switching pattern of the output devices, resulting in a number of important benefits.

- Σ - Δ modulators do not produce a sharp peak with many harmonics in the AM frequency band, as pulse-width modulators often do.
- Σ - Δ modulation provides the benefits of reducing the amplitude of spectral components at high frequencies, that is, reducing EMI emissions that might otherwise be radiated by speakers and long cable traces.
- Due to the inherent spread-spectrum nature of Σ - Δ modulation, the need for oscillator synchronization is eliminated for designs that incorporate multiple SSM2377 amplifiers.

The SSM2377 also integrates overcurrent and overtemperature protection.

GAIN SELECTION

The preset gain of the SSM2377 can be set to 6 dB or 12 dB using the GAIN pin, as shown in Table 5.

Table 5. GAIN Pin Function Description

Gain Setting (dB)	GAIN Pin Configuration
6	Tie to VDD
12	Tie to GND

POP-AND-CLICK SUPPRESSION

Voltage transients at the output of audio amplifiers can occur when shutdown is activated or deactivated. Voltage transients as low as 10 mV can be heard as an audible pop in the speaker. Clicks and pops can also be classified as undesirable audible transients generated by the amplifier system and, therefore, as not coming from the system input signal.

The SSM2377 has a pop-and-click suppression architecture that reduces these output transients, resulting in noiseless activation and deactivation from the \overline{SD} control pin.

EMI NOISE

The SSM2377 uses a proprietary modulation and spread-spectrum technology to minimize EMI emissions from the device. For applications that have difficulty passing FCC Class B emission tests or experience antenna and RF sensitivity problems, the ultralow EMI architecture of the SSM2377 significantly reduces the radiated emissions at the Class-D outputs, particularly above 100 MHz. Figure 35 shows the low radiated emissions from the SSM2377 due to its ultralow EMI architecture.

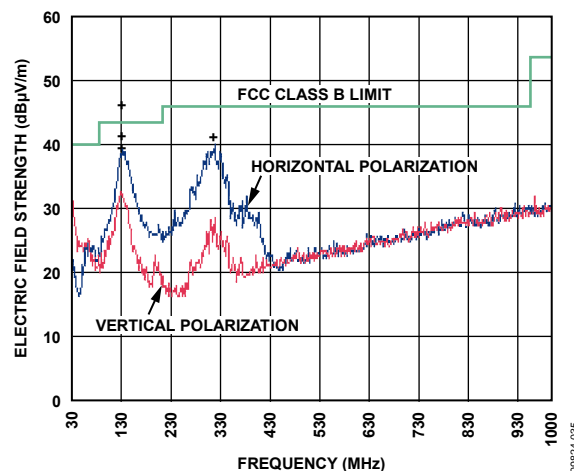

Figure 35. EMI Emissions from the SSM2377

The measurements for Figure 35 were taken in an FCC-certified EMI laboratory with a 1 kHz input signal, producing 1.0 W of output power into an 8 Ω load from a 5.0 V supply. The SSM2377 passed FCC Class B limits with 50 cm, unshielded twisted pair speaker cable. Note that reducing the power supply voltage greatly reduces radiated emissions.

OUTPUT MODULATION DESCRIPTION

The SSM2377 uses three-level, Σ - Δ output modulation. Each output can swing from GND to V_{DD} and vice versa. Ideally, when no input signal is present, the output differential voltage is 0 V because there is no need to generate a pulse. In a real-world situation, noise sources are always present.

Due to the constant presence of noise, a differential pulse is generated, when required, in response to this stimulus. A small amount of current flows into the inductive load when the differential pulse is generated.

Most of the time, however, the output differential voltage is 0 V, due to the Analog Devices, Inc., three-level, Σ - Δ output modulation. This feature ensures that the current flowing through the inductive load is small.

SSM2377

When the user wants to send an input signal, an output pulse (OUT+ and OUT-) is generated to follow the input voltage. The differential pulse density (V_{OUT}) is increased by raising the input signal level. Figure 36 depicts three-level, Σ - Δ output modulation with and without input stimulus.

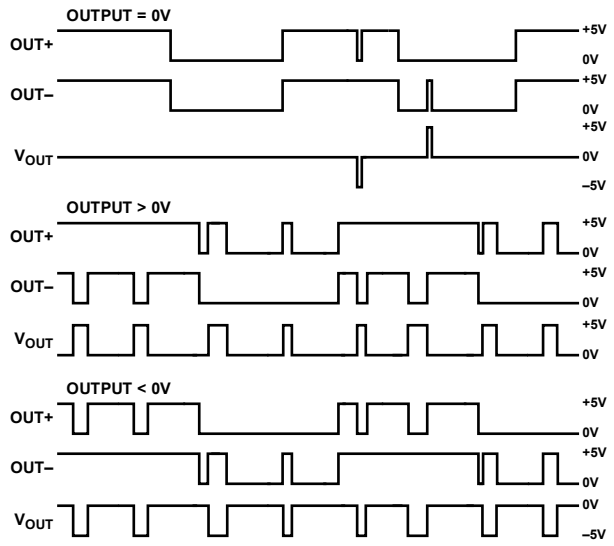

Figure 36. Three-Level, Σ - Δ Output Modulation With and Without Input Stimulus

LAYOUT

As output power increases, care must be taken to lay out PCB traces and wires properly among the amplifier, load, and power supply. A good practice is to use short, wide PCB tracks to decrease voltage drops and minimize inductance. Ensure that track widths are at least 200 mil for every inch of track length for lowest DCR, and use 1 oz or 2 oz copper PCB traces to further reduce IR drops and inductance. A poor layout increases voltage drops, consequently affecting efficiency. Use large traces for the power supply inputs and amplifier outputs to minimize losses due to parasitic trace resistance.

Proper grounding guidelines help to improve audio performance, minimize crosstalk between channels, and prevent switching noise from coupling into the audio signal. To maintain high output swing and high peak output power, the PCB traces that connect the output pins to the load, as well as the PCB traces to the supply pins, should be as wide as possible to maintain the minimum trace resistances. It is also recommended that a large ground plane be used for minimum impedances.

In addition, good PCB layout isolates critical analog paths from sources of high interference. High frequency circuits (analog and digital) should be separated from low frequency circuits.

Properly designed multilayer PCBs can reduce EMI emissions and increase immunity to the RF field by a factor of 10 or more, compared with double-sided boards. A multilayer board allows a complete layer to be used for the ground plane, whereas the ground plane side of a double-sided board is often disrupted by signal crossover.

If the system has separate analog and digital ground and power planes, the analog ground plane should be directly beneath the analog power plane, and, similarly, the digital ground plane should be directly beneath the digital power plane. There should be no overlap between the analog and digital ground planes or between the analog and digital power planes.

INPUT CAPACITOR SELECTION

The SSM2377 does not require input coupling capacitors if the input signal is biased from 1.0 V to $V_{DD} - 1.0$ V. Input capacitors are required if the input signal is not biased within this recommended input dc common-mode voltage range, if high-pass filtering is needed, or if a single-ended source is used. If high-pass filtering is needed at the input, the input capacitor (C_{IN}) and the input impedance of the SSM2377 form a high-pass filter with a corner frequency determined by the following equation:

$$f_c = 1/(2\pi \times 80 \text{ k}\Omega \times C_{IN})$$

The input capacitor value and the dielectric material can significantly affect the performance of the circuit. Not using input capacitors can generate a large dc output offset voltage and degrade the dc PSRR performance.

POWER SUPPLY DECOUPLING

To ensure high efficiency, low total harmonic distortion (THD), and high PSRR, proper power supply decoupling is necessary. Noise transients on the power supply lines are short-duration voltage spikes. These spikes can contain frequency components that extend into the hundreds of megahertz. The power supply input must be decoupled with a good quality, low ESL, low ESR capacitor, with a minimum value of 4.7 μ F. This capacitor bypasses low frequency noises to the ground plane. For high frequency transient noises, use a 0.1 μ F capacitor as close as possible to the VDD pins of the device. Placing the decoupling capacitors as close as possible to the SSM2377 helps to maintain efficient performance.

OUTLINE DIMENSIONS

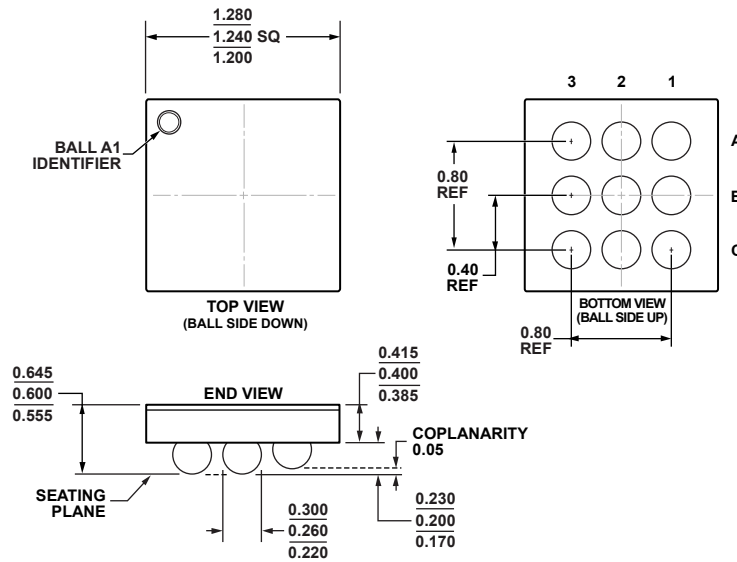

08-23-2010-A

Figure 37. 9-Ball Wafer Level Chip Scale Package [WLCSP]
(CB-9-4)
Dimensions shown in millimeters

ORDERING GUIDE

Model ¹	Temperature Range	Package Description	Package Option ²	Branding
SSM2377ACBZ-RL	-40°C to +85°C	9-Ball Wafer Level Chip Scale Package [WLCSP]	CB-9-4	Y48
SSM2377ACBZ-R7	-40°C to +85°C	9-Ball Wafer Level Chip Scale Package [WLCSP]	CB-9-4	Y48
EVAL-SSM2377Z		Evaluation Board		

¹ Z = RoHS Compliant Part.

² This package option is halide free.

SSM2377

NOTES

Looking for pricing, stock, or lifecycle information?

Click below to explore more details on WIN SOURCE:

 [View SSM2377ACBZ-R7 on WIN SOURCE](#)

 [Analog Devices Inc. Information](#)

Optimize Your Supply Chain with WIN SOURCE Solutions

-  Global Sourcing Solution
-  Obsolete Management
-  Cost Control Management
-  Shortage Management
-  Alternative Solution
-  Excess Inventory Management