



Is Now Part of



ON Semiconductor®

To learn more about ON Semiconductor, please visit our website at
www.onsemi.com

Please note: As part of the Fairchild Semiconductor integration, some of the Fairchild orderable part numbers will need to change in order to meet ON Semiconductor's system requirements. Since the ON Semiconductor product management systems do not have the ability to manage part nomenclature that utilizes an underscore (_), the underscore (_) in the Fairchild part numbers will be changed to a dash (-). This document may contain device numbers with an underscore (_). Please check the ON Semiconductor website to verify the updated device numbers. The most current and up-to-date ordering information can be found at www.onsemi.com. Please email any questions regarding the system integration to Fairchild_questions@onsemi.com.

ON Semiconductor and the ON Semiconductor logo are trademarks of Semiconductor Components Industries, LLC dba ON Semiconductor or its subsidiaries in the United States and/or other countries. ON Semiconductor owns the rights to a number of patents, trademarks, copyrights, trade secrets, and other intellectual property. A listing of ON Semiconductor's product/patent coverage may be accessed at www.onsemi.com/site/pdf/Patent-Marking.pdf. ON Semiconductor reserves the right to make changes without further notice to any products herein. ON Semiconductor makes no warranty, representation or guarantee regarding the suitability of its products for any particular purpose, nor does ON Semiconductor assume any liability arising out of the application or use of any product or circuit, and specifically disclaims any and all liability, including without limitation special, consequential or incidental damages. Buyer is responsible for its products and applications using ON Semiconductor products, including compliance with all laws, regulations and safety requirements or standards, regardless of any support or applications information provided by ON Semiconductor. "Typical" parameters which may be provided in ON Semiconductor data sheets and/or specifications can and do vary in different applications and actual performance may vary over time. All operating parameters, including "Typicals" must be validated for each customer application by customer's technical experts. ON Semiconductor does not convey any license under its patent rights nor the rights of others. ON Semiconductor products are not designed, intended, or authorized for use as a critical component in life support systems or any FDA Class 3 medical devices or medical devices with a same or similar classification in a foreign jurisdiction or any devices intended for implantation in the human body. Should Buyer purchase or use ON Semiconductor products for any such unintended or unauthorized application, Buyer shall indemnify and hold ON Semiconductor and its officers, employees, subsidiaries, affiliates, and distributors harmless against all claims, costs, damages, and expenses, and reasonable attorney fees arising out of, directly or indirectly, any claim of personal injury or death associated with such unintended or unauthorized use, even if such claim alleges that ON Semiconductor was negligent regarding the design or manufacture of the part. ON Semiconductor is an Equal Opportunity/Affirmative Action Employer. This literature is subject to all applicable copyright laws and is not for resale in any manner.

74LCX74

Low Voltage Dual D-Type Positive Edge-Triggered Flip-Flop with 5V Tolerant Inputs

Features

- 5V tolerant inputs
- 2.3V–3.6V V_{CC} specifications provided
- 7.0ns t_{PD} max. ($V_{CC} = 3.3V$), $10\mu A$ I_{CC} max.
- Power down high impedance inputs and outputs
- $\pm 24mA$ output drive ($V_{CC} = 3.0V$)
- Implements proprietary noise/EMI reduction circuitry
- Latch-up performance exceeds JEDEC 78 conditions
- ESD performance:
 - Human body model > 2000V
 - Machine model > 200V
- Leadless Pb-Free DQFN package

General Description

The LCX74 is a dual D-type flip-flop with Asynchronous Clear and Set inputs and complementary (Q, \bar{Q}) outputs. Information at the input is transferred to the outputs on the positive edge of the clock pulse. After the Clock Pulse input threshold voltage has been passed, the Data input is locked out and information present will not be transferred to the outputs until the next rising edge of the Clock Pulse input.

Asynchronous Inputs:

- LOW input to \bar{S}_D (Set) sets Q to HIGH level
- LOW input to \bar{C}_D (Clear) sets Q to LOW level
- Clear and Set are independent of clock
- Simultaneous LOW on \bar{C}_D and \bar{S}_D makes both Q and \bar{Q} HIGH

Ordering Information

| Order Number | Package Number | Package Description |
|---------------------------|----------------|---|
| 74LCX74M | M14A | 14-Lead Small Outline Integrated Circuit (SOIC), JEDEC MS-012, 0.150" Narrow |
| 74LCX74SJ | M14D | 14-Lead Small Outline Package (SOP), EIAJ TYPE II, 5.3mm Wide |
| 74LCX74BQX ⁽¹⁾ | MLP14A | 14-Terminal Depopulated Quad Very-Thin Flat Pack No Leads (DQFN), JEDEC MO-241, 2.5 x 3.0mm |
| 74LCX74MTC | MTC14 | 14-Lead Thin Shrink Small Outline Package (TSSOP), JEDEC MO-153, 4.4mm Wide |

Note:

1. DQFN package available in Tape and Reel only.

Device also available in Tape and Reel. Specify by appending suffix letter "X" to the ordering number.

 All packages are lead free per JEDEC: J-STD-020B standard.

Connection Diagrams

Pin Assignments for SOIC, SOP, and TSSOP

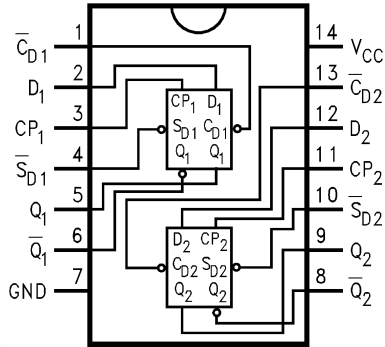

Pad Assignment for DQFN

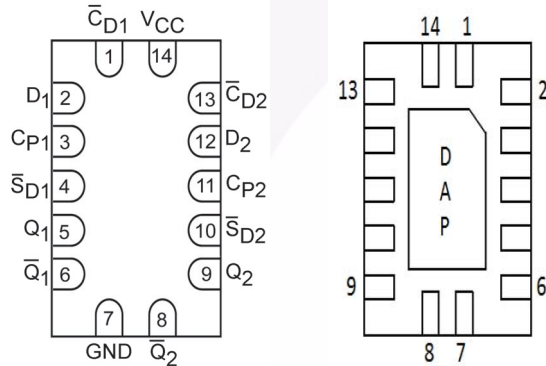

(Top View)

(Bottom View)

Pin Description

| Pin Names | Description |
|---|---------------------|
| D ₁ , D ₂ | Data Inputs |
| CP ₁ , CP ₂ | Clock Pulse Inputs |
| C _{D1} , C _{D2} | Direct Clear Inputs |
| S _{D1} , S _{D2} | Direct Set Inputs |
| Q ₁ , Q ₁ [̄] , Q ₂ , Q ₂ [̄] | Outputs |
| DAP | No Connect |

Note: DAP (Die Attach Pad)

Logic Symbols

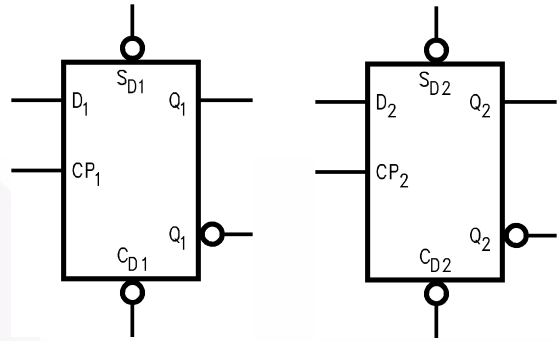

IEEE/IEC

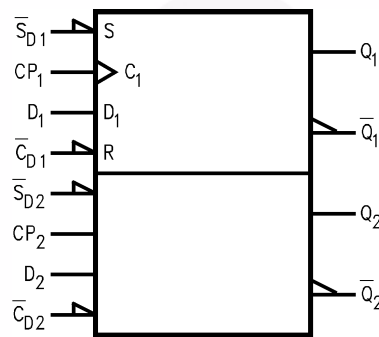

Truth Table

(Each Half)

| Inputs | | | | Outputs | |
|----------------|----------------|----|---|----------------|-----------------------------|
| S _D | C _D | CP | D | Q | Q [̄] |
| L | H | X | X | H | L |
| H | L | X | X | L | H |
| L | L | X | X | H | H |
| H | H | ↗ | H | H | L |
| H | H | ↘ | L | L | H |
| H | H | L | X | Q ₀ | Q ₀ [̄] |

H = HIGH Voltage Level

L = LOW Voltage Level

X = Immaterial

↗ = LOW-to-HIGH Clock Transition

Q₀(Q₀[̄]) = Previous Q(Q[̄]) before LOW-to-HIGH Transition of Clock

Absolute Maximum Ratings

Stresses exceeding the absolute maximum ratings may damage the device. The device may not function or be operable above the recommended operating conditions and stressing the parts to these levels is not recommended. In addition, extended exposure to stresses above the recommended operating conditions may affect device reliability. The absolute maximum ratings are stress ratings only.

| Symbol | Parameter | Rating |
|-----------|---|--------------------------|
| V_{CC} | Supply Voltage | -0.5V to +7.0V |
| V_I | DC Input Voltage | -0.5V to +7.0V |
| V_O | DC Output Voltage, Output in HIGH or LOW State ⁽²⁾ | -0.5V to $V_{CC} + 0.5V$ |
| I_{IK} | DC Input Diode Current, $V_I < GND$ | -50mA |
| I_{OK} | DC Output Diode Current $V_O < GND$ | -50mA |
| | $V_O > V_{CC}$ | +50mA |
| I_O | DC Output Source/Sink Current | $\pm 50mA$ |
| I_{CC} | DC Supply Current per Supply Pin | $\pm 100mA$ |
| I_{GND} | DC Ground Current per Ground Pin | $\pm 100mA$ |
| T_{STG} | Storage Temperature | -65°C to +150°C |

Note:

2. I_O Absolute Maximum Rating must be observed.

Recommended Operating Conditions⁽³⁾

The Recommended Operating Conditions table defines the conditions for actual device operation. Recommended operating conditions are specified to ensure optimal performance to the datasheet specifications. Fairchild does not recommend exceeding them or designing to absolute maximum ratings.

| Symbol | Parameter | Min. | Max. | Units |
|-----------------------|---|------|----------|-------|
| V_{CC} | Supply Voltage Operating | 2.0 | 3.6 | V |
| | Data Retention | 1.5 | 3.6 | |
| V_I | Input Voltage | 0 | 5.5 | V |
| V_O | Output Voltage, HIGH or LOW State | 0 | V_{CC} | V |
| I_{OH} / I_{OL} | Output Current $V_{CC} = 3.0V-3.6V$ | | ± 24 | mA |
| | $V_{CC} = 2.7V-3.0V$ | | ± 12 | |
| | $V_{CC} = 2.3V-2.7V$ | | ± 8 | |
| T_A | Free-Air Operating Temperature | -40 | 85 | °C |
| $\Delta t / \Delta V$ | Input Edge Rate, $V_{IN} = 0.8V-2.0V$, $V_{CC} = 3.0V$ | 0 | 10 | ns/V |

Note:

3. Unused inputs must be held HIGH or LOW. They may not float.

DC Electrical Characteristics

| Symbol | Parameter | V _{CC} (V) | Conditions | T _A = -40°C to +85°C | | Units |
|------------------|---------------------------------------|---------------------|--|---------------------------------|------|-------|
| | | | | Min. | Max. | |
| V _{IH} | HIGH Level Input Voltage | 2.3–2.7 | | 1.7 | | V |
| | | 2.7–3.6 | | 2.0 | | |
| V _{IL} | LOW Level Input Voltage | 2.3–2.7 | | | 0.7 | V |
| | | 2.7–3.6 | | | 0.8 | |
| V _{OH} | HIGH Level Output Voltage | 2.3–3.6 | I _{OH} = -100μA | V _{CC} - 0.2 | | V |
| | | 2.3 | I _{OH} = -8mA | 1.8 | | |
| | | 2.7 | I _{OH} = -12mA | 2.2 | | |
| | | 3.0 | I _{OH} = -18mA | 2.4 | | |
| | | | I _{OH} = -24mA | 2.2 | | |
| V _{OL} | LOW Level Output Voltage | 2.3–3.6 | I _{OL} = 100μA | | 0.2 | V |
| | | 2.3 | I _{OL} = 8mA | | 0.6 | |
| | | 2.7 | I _{OL} = 12mA | | 0.4 | |
| | | 3.0 | I _{OL} = 16mA | | 0.4 | |
| | | | I _{OL} = 24mA | | 0.55 | |
| I _I | Input Leakage Current | 2.3–3.6 | 0 ≤ V _I ≤ 5.5V | | ±5.0 | μA |
| I _{OFF} | Power-Off Leakage Current | 0 | V _I or V _O = 5.5V | | 10 | μA |
| I _{CC} | Quiescent Supply Current | 2.3–3.6 | V _I = V _{CC} or GND | | 10 | μA |
| | | | 3.6V ≤ V _I ≤ 5.5V | | ±10 | |
| ΔI _{CC} | Increase in I _{CC} per Input | 2.3–3.6 | V _{IH} = V _{CC} - 0.6V | | 500 | μA |

AC Electrical Characteristics

| Symbol | Parameter | T _A = -40°C to +85°C, R _L = 500Ω | | | | | | Units |
|---------------------------------------|--|---|------|--|------|---|------|-------|
| | | V _{CC} = 3.3V ± 0.3V, C _L = 50pF | | V _{CC} = 2.7V, C _L = 50pF | | V _{CC} = 2.5V ± 0.2V, C _L = 30pF | | |
| | | Min. | Max. | Min. | Max. | Min. | Max. | |
| f _{MAX} | Maximum Clock Frequency | 150 | | 150 | | 150 | | MHz |
| t _{PHL} , t _{PLH} | Propagation Delay, CP _n to Q _n or \overline{Q}_n | 1.5 | 7.0 | 1.5 | 8.0 | 1.5 | 8.4 | ns |
| t _{PHL} , t _{PLH} | Propagation Delay, \overline{C}_Dn or \overline{S}_Dn to Q _n or \overline{Q}_n | 1.5 | 7.0 | 1.5 | 8.0 | 1.5 | 8.4 | ns |
| t _S | Setup Time | 2.5 | | 2.5 | | 4.0 | | ns |
| t _H | Hold Time | 1.5 | | 1.5 | | 2.0 | | ns |
| t _W | Pulse Width CP | 3.3 | | 3.3 | | 4.0 | | ns |
| t _W | Pulse Width and \overline{C}_D , \overline{S}_D | 3.3 | | 3.6 | | 4.0 | | ns |
| t _{REC} | Recovery Time | 2.5 | | 3.0 | | 4.5 | | ns |
| t _{OSHL} , t _{OSLH} | Output to Output Skew ⁽⁴⁾ | | 1.0 | | | | | ns |

Note:

4. Skew is defined as the absolute value of the difference between the actual propagation delay for any two separate outputs of the same device. The specification applies to any outputs switching in the same direction, either HIGH-to-LOW (t_{OSHL}) or LOW-to-HIGH (t_{OSLH}).

Dynamic Switching Characteristics

| Symbol | Parameter | V _{CC} (V) | Conditions | T _A = 25°C | |
|------------------|---|---------------------|---|-----------------------|------|
| | | | | Typical | Unit |
| V _{OLP} | Quiet Output Dynamic Peak V _{OL} | 3.3 | C _L = 50pF, V _{IH} = 3.3V, V _{IL} = 0V | 0.8 | V |
| | | 2.5 | C _L = 30pF, V _{IH} = 2.5V, V _{IL} = 0V | 0.6 | |
| V _{OLV} | Quiet Output Dynamic Valley V _{OL} | 3.3 | C _L = 50pF, V _{IH} = 3.3V, V _{IL} = 0V | -0.8 | V |
| | | 2.5 | C _L = 30pF, V _{IH} = 2.5V, V _{IL} = 0V | -0.6 | |

Capacitance

| Symbol | Parameter | Conditions | Typical | Units |
|------------------|-------------------------------|--|---------|-------|
| C _{IN} | Input Capacitance | V _{CC} = Open, V _I = 0V or V _{CC} | 7 | pF |
| C _{OUT} | Output Capacitance | V _{CC} = 3.3V, V _I = 0V or V _{CC} | 8 | pF |
| C _{PD} | Power Dissipation Capacitance | V _{CC} = 3.3V, V _I = 0V or V _{CC} , f = 10MHz | 25 | pF |

AC Loading and Waveforms (Generic for LCX Family)

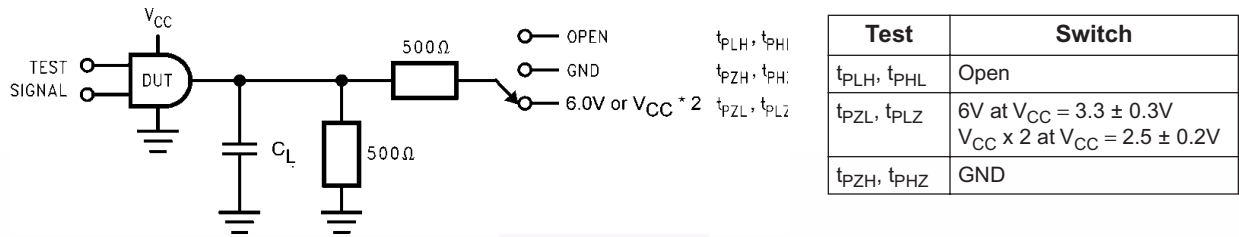
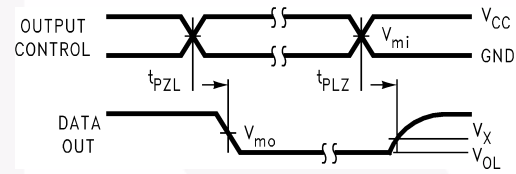
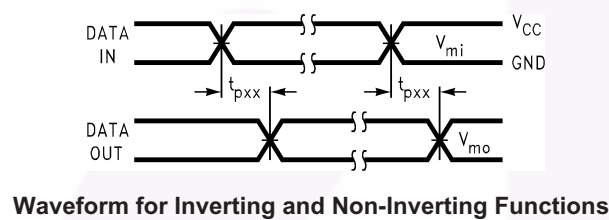
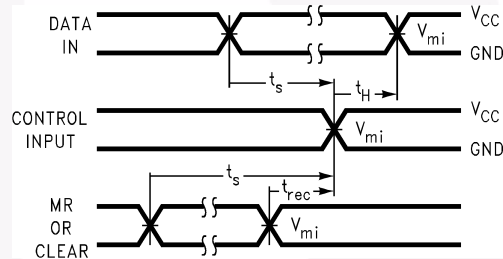
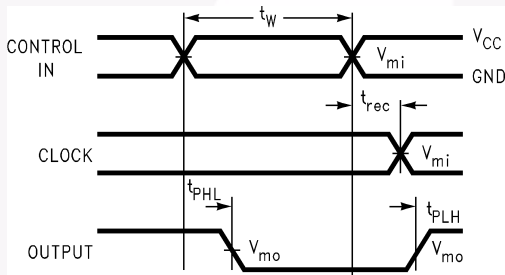

Figure 1. AC Test Circuit (C_L includes probe and jig capacitance)



Waveform for Inverting and Non-Inverting Functions

3-STATE Output Low Enable and Disable Times for Logic



Propagation Delay, Pulse Width and t_{rec} Waveforms

Setup Time, Hold Time and Recovery Time for Logic

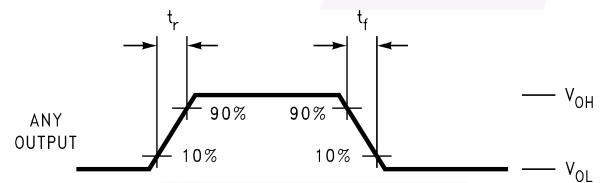
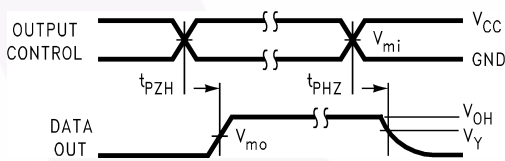

3-STATE Output High Enable and Disable Times for Logic

t_{rise} and t_{fall}

| Symbol | V_{CC} | | |
|----------|-----------------|-----------------|------------------|
| | $3.3V \pm 0.3V$ | 2.7V | $2.5V \pm 0.2V$ |
| V_{mi} | 1.5V | 1.5V | $V_{CC}/2$ |
| V_{mo} | 1.5V | 1.5V | $V_{CC}/2$ |
| V_x | $V_{OL} + 0.3V$ | $V_{OL} + 0.3V$ | $V_{OL} + 0.15V$ |
| V_y | $V_{OH} - 0.3V$ | $V_{OH} - 0.3V$ | $V_{OH} - 0.15V$ |

Figure 2. Waveforms (Input Characteristics; $f = 1MHz, t_r = t_f = 3ns$)

Schematic Diagram (Generic for LCX Family)

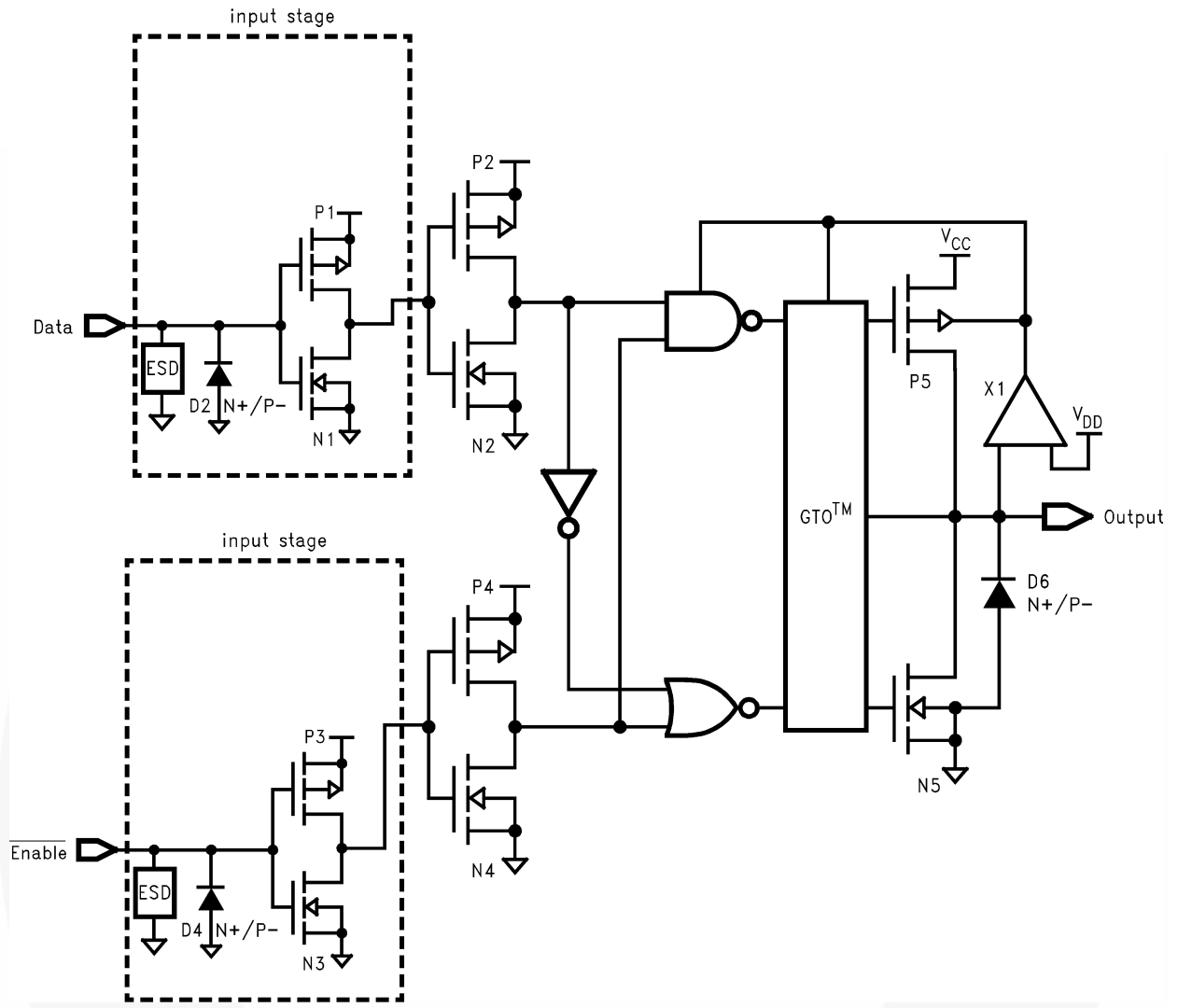

Tape and Reel Specification

Tape Format for DQFN

| Package Designator | Tape Section | Number of Cavities | Cavity Status | Cover Tape Status |
|--------------------|--------------------|--------------------|---------------|-------------------|
| BQX | Leader (Start End) | 125 (Typ.) | Empty | Sealed |
| | Carrier | 3000 | Filled | Sealed |
| | Trailer (Hub End) | 75 (Typ.) | Empty | Sealed |

Tape Dimensions inches (millimeters)

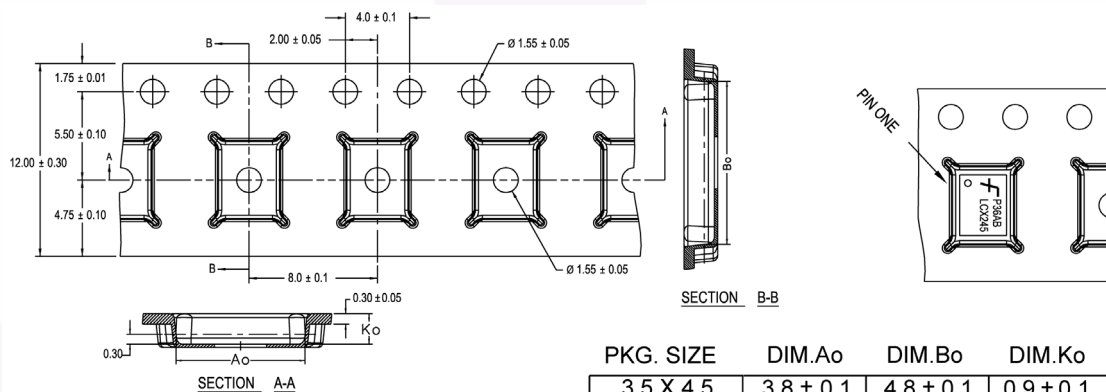

| PKG. SIZE | DIM.Ao | DIM.Bo | DIM.Ko |
|-----------|-----------|-----------|-----------|
| 3.5 X 4.5 | 3.8 ± 0.1 | 4.8 ± 0.1 | 0.9 ± 0.1 |
| 3.0 X 3.0 | 3.3 ± 0.1 | 3.3 ± 0.1 | 0.9 ± 0.1 |
| 2.5 X 4.5 | 2.8 ± 0.1 | 4.8 ± 0.1 | 0.9 ± 0.1 |
| 2.5 X 3.5 | 2.8 ± 0.1 | 3.8 ± 0.1 | 0.9 ± 0.1 |
| 2.5 X 3.0 | 2.8 ± 0.1 | 3.3 ± 0.1 | 0.9 ± 0.1 |
| 2.5 X 2.5 | 2.8 ± 0.1 | 2.8 ± 0.1 | 0.9 ± 0.1 |

DIMENSIONS ARE IN MILLIMETERS

NOTES: unless otherwise specified

1. Cumulative pitch for feeding holes and cavities (chip pockets) not to exceed 0.008[0.20] over 10 pitch span.
2. Smallest allowable bending radius.
3. Thru hole inside cavity is centered within cavity.
4. Tolerance is $\pm 0.002[0.05]$ for these dimensions on all 12mm tapes.
5. A_o and B_o measured on a plane 0.120[0.30] above the bottom of the pocket.
6. K_o measured from a plane on the inside bottom of the pocket to the top surface of the carrier.
7. Pocket position relative to sprocket hole measured as true position of pocket. Not pocket hole.
8. Controlling dimension is millimeter. Dimension in inches rounded.

Reel Dimensions inches (millimeters)

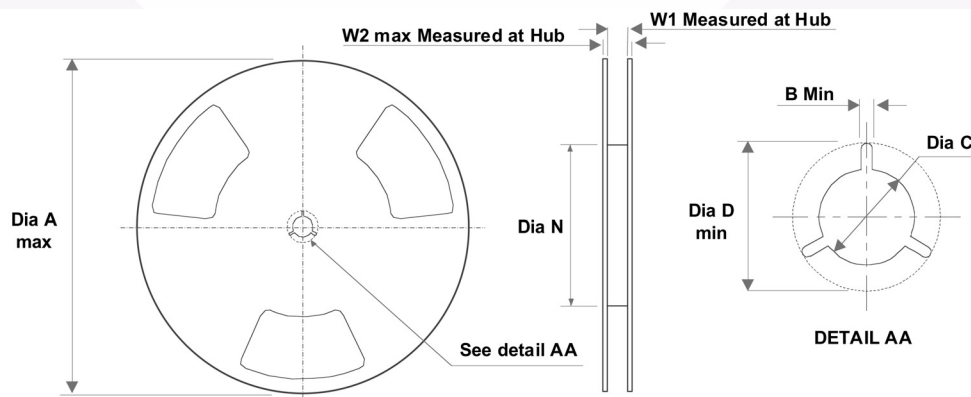

| Tape Size | A | B | C | D | N | W1 | W2 |
|-----------|--------------|--------------|---------------|---------------|---------------|--------------|--------------|
| 12mm | 13.0 (330.0) | 0.059 (1.50) | 0.512 (13.00) | 0.795 (20.20) | 2.165 (55.00) | 0.488 (12.4) | 0.724 (18.4) |

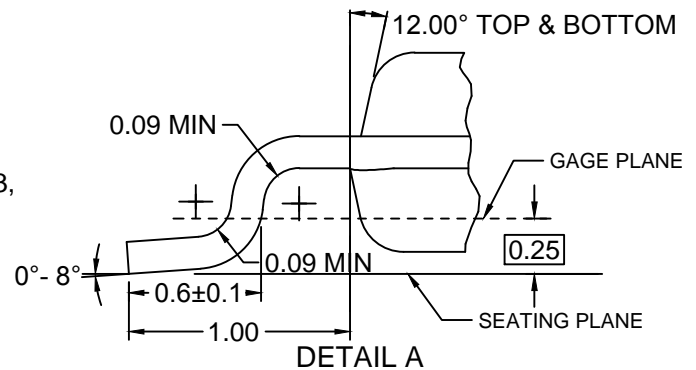
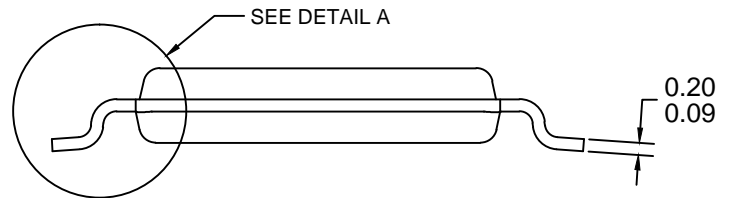
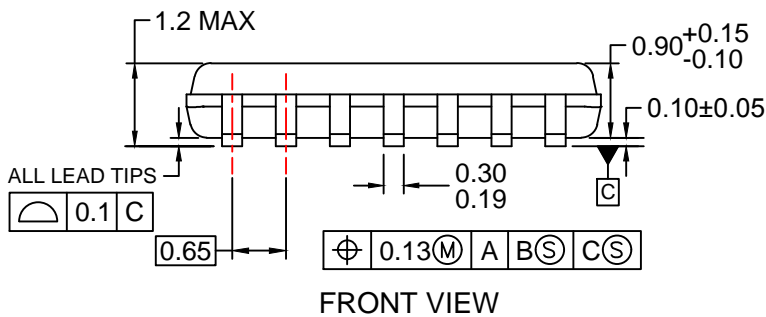
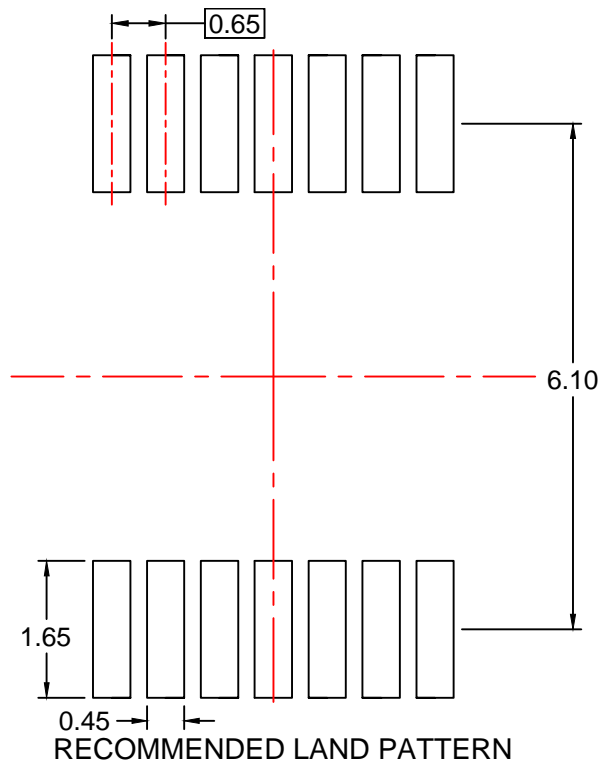
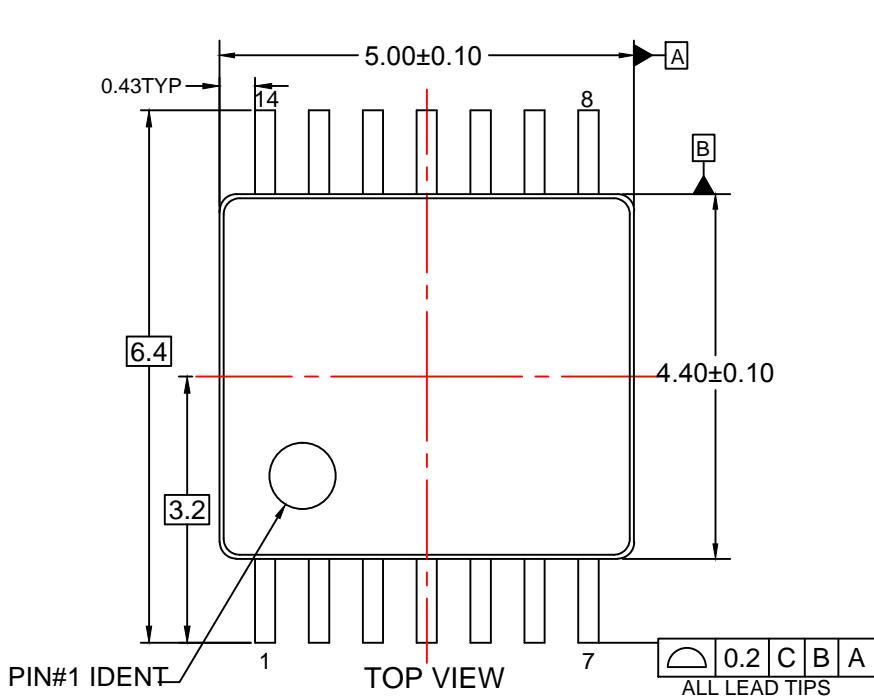

NOTES:

- A. CONFORMS TO JEDEC REGISTRATION MO-153, VARIATION AB, REF NOTE 6
- B. DIMENSIONS ARE IN MILLIMETERS.
- C. DIMENSIONS ARE EXCLUSIVE OF BURRS, MOLD FLASH, AND TIE BAR EXTRUSIONS
- D. DIMENSIONING AND TOLERANCES PER ANSI Y14.5M, 2009.
- E. LANDPATTERN STANDARD: SOP65P640X110-14M.
- F. DRAWING FILE NAME: MKT-MTC14rev7.



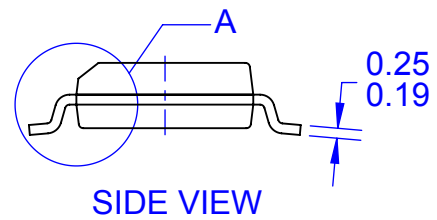
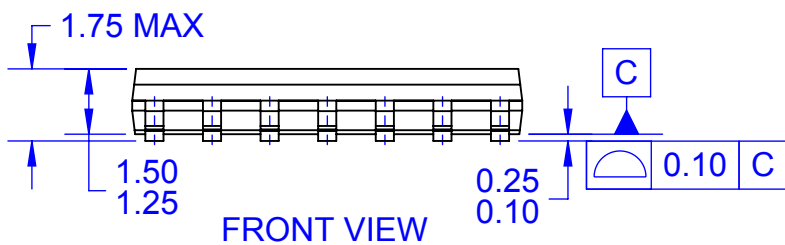
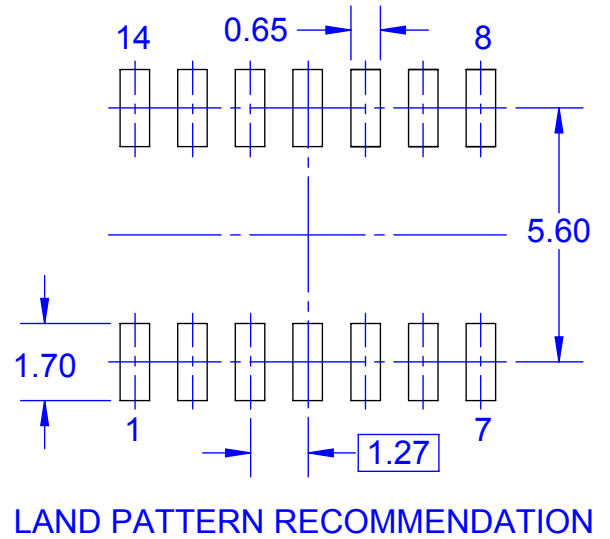
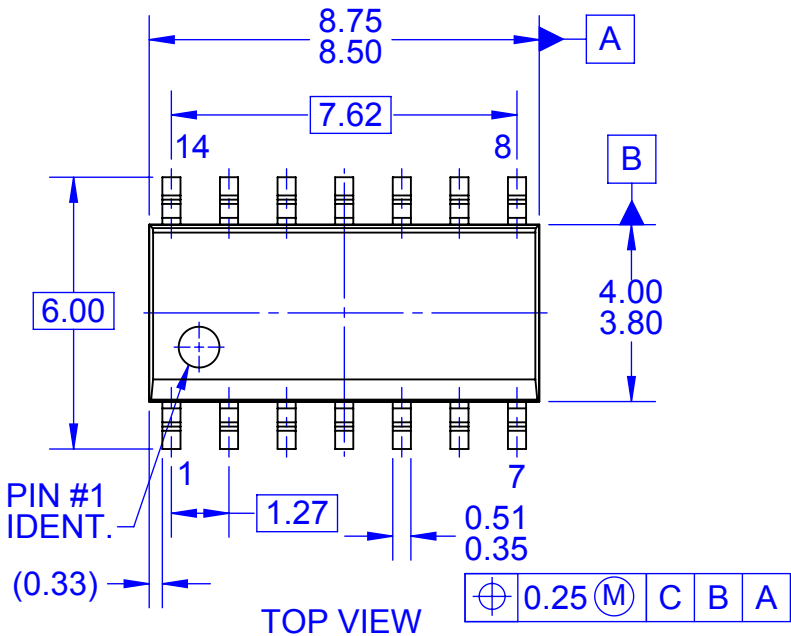

NOTES:

- A. CONFORMS TO JEDEC MS-012, VARIATION AB, ISSUE C
- B. ALL DIMENSIONS ARE IN MILLIMETERS
- C. DIMENSIONS DO NOT INCLUDE MOLD FLASH OR BURRS
- D. LAND PATTERN STANDARD: SOIC127P600X145-14M
- E. CONFORMS TO ASME Y14.5M, 2009
- D. DRAWING FILENAME: MKT-M14Arev14





BOTTOM VIEW

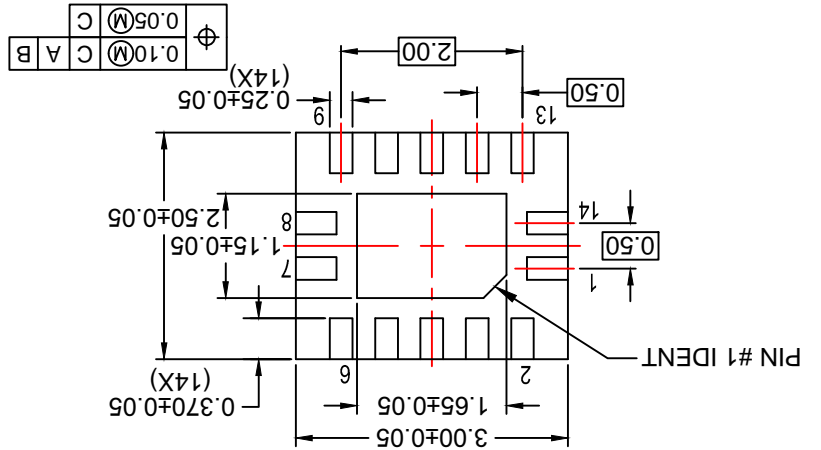

SIDE VIEW

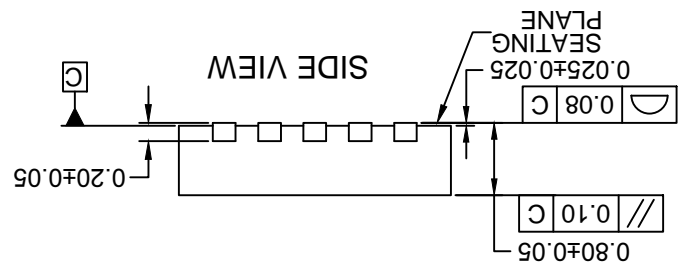

TOP VIEW

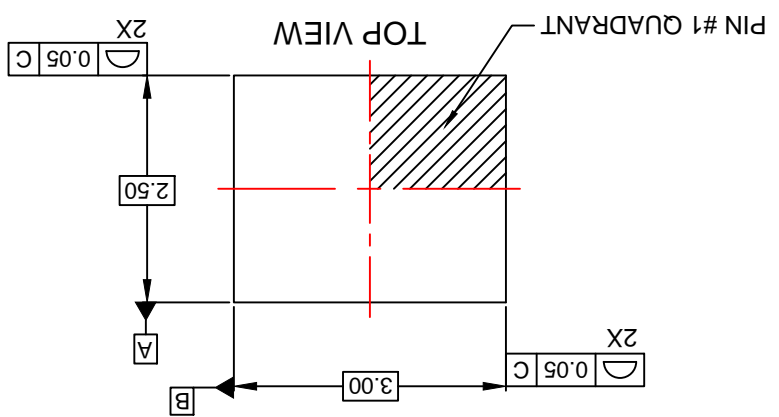

- NOTES:**
 A. CONFORMS TO JEDEC REGISTRATION MO-241, VARIATION AA
 B. DIMENSIONS ARE IN MILLIMETERS.
 C. DIMENSIONS AND TOLERANCES PER ASME Y14.5M, 2009.
 D. LAND PATTERN RECOMMENDATION IS EXISTING INDUSTRY LAND PATTERN.
 E. DRAWING FILENAME: MKT-MLP14Arev2.

RECOMMENDED LAND PATTERN

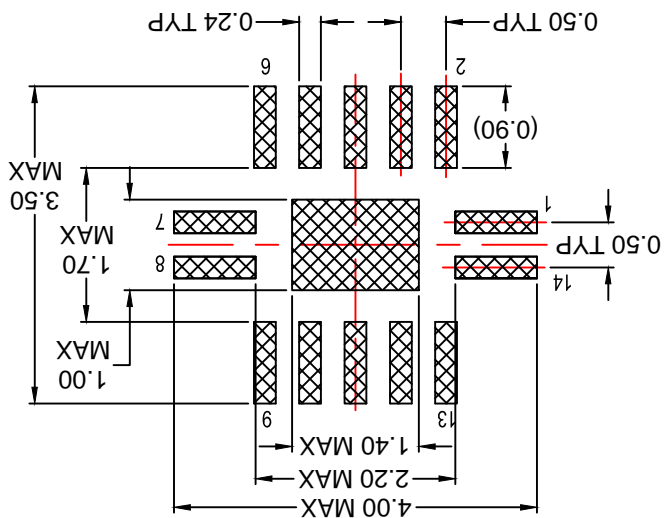

ON Semiconductor and  are trademarks of Semiconductor Components Industries, LLC dba ON Semiconductor or its subsidiaries in the United States and/or other countries. ON Semiconductor owns the rights to a number of patents, trademarks, copyrights, trade secrets, and other intellectual property. A listing of ON Semiconductor's product/patent coverage may be accessed at www.onsemi.com/site/pdf/Patent-Marking.pdf. ON Semiconductor reserves the right to make changes without further notice to any products herein. ON Semiconductor makes no warranty, representation or guarantee regarding the suitability of its products for any particular purpose, nor does ON Semiconductor assume any liability arising out of the application or use of any product or circuit, and specifically disclaims any and all liability, including without limitation special, consequential or incidental damages. Buyer is responsible for its products and applications using ON Semiconductor products, including compliance with all laws, regulations and safety requirements or standards, regardless of any support or applications information provided by ON Semiconductor. "Typical" parameters which may be provided in ON Semiconductor data sheets and/or specifications can and do vary in different applications and actual performance may vary over time. All operating parameters, including "Typicals" must be validated for each customer application by customer's technical experts. ON Semiconductor does not convey any license under its patent rights nor the rights of others. ON Semiconductor products are not designed, intended, or authorized for use as a critical component in life support systems or any FDA Class 3 medical devices or medical devices with a same or similar classification in a foreign jurisdiction or any devices intended for implantation in the human body. Should Buyer purchase or use ON Semiconductor products for any such unintended or unauthorized application, Buyer shall indemnify and hold ON Semiconductor and its officers, employees, subsidiaries, affiliates, and distributors harmless against all claims, costs, damages, and expenses, and reasonable attorney fees arising out of, directly or indirectly, any claim of personal injury or death associated with such unintended or unauthorized use, even if such claim alleges that ON Semiconductor was negligent regarding the design or manufacture of the part. ON Semiconductor is an Equal Opportunity/Affirmative Action Employer. This literature is subject to all applicable copyright laws and is not for resale in any manner.

PUBLICATION ORDERING INFORMATION

LITERATURE FULFILLMENT:



Literature Distribution Center for ON Semiconductor
19521 E. 32nd Pkwy, Aurora, Colorado 80011 USA
Phone: 303-675-2175 or 800-344-3860 Toll Free USA/Canada
Fax: 303-675-2176 or 800-344-3867 Toll Free USA/Canada
Email: orderlit@onsemi.com

N. American Technical Support: 800-282-9855 Toll Free
USA/Canada
Europe, Middle East and Africa Technical Support:
Phone: 421 33 790 2910
Japan Customer Focus Center
Phone: 81-3-5817-1050

ON Semiconductor Website: www.onsemi.com
Order Literature: <http://www.onsemi.com/orderlit>
For additional information, please contact your local
Sales Representative

Looking for pricing, stock, or lifecycle information?

Click below to explore more details on WIN SOURCE:

-  [View 74LCX74MX on WIN SOURCE](#)
-  [Fairchild/ON Semiconductor Information](#)

Optimize Your Supply Chain with WIN SOURCE Solutions

-  Global Sourcing Solution
-  Obsolete Management
-  Cost Control Management
-  Shortage Management
-  Alternative Solution
-  Excess Inventory Management