



**THE DATASHEET OF  
SSL21082AT/1,118**





# SSL21082AT

Mains dimmable LED driver IC

Rev. 6 — 3 October 2013

Product data sheet

## 1. General description

---

The SSL21082AT is a high-voltage Integrated Circuit (IC) for driving retrofit LED lamps in general lighting applications. It enables the implementation of a very compact low-cost system solution. The IC has an integrated internal HV switch and work as Boundary Conduction Mode (BCM) buck converter.

The SSL21082AT is supplied by a start-up bleeder resistor, a  $dV/dt$  supply using capacitive coupling from the drain or any other auxiliary supply. The IC supply current is low. An internal clamp limits the supply voltage.

The IC has an accurate output current control and can be operated using Pulse-Width Modulation (PWM) dimming. In addition, several protection features are available such as easy external temperature feedback.

The main benefits of this IC include:

- Small Printed-Circuit Board (PCB) footprint and compact solution
- High efficiency (up to 90 %) for non-dimmable high power factor solutions
- High power factor ( $>0.9$ )
- Ease of integration and many protection features
- Low electronic Bill Of Material (BOM)
- Mains phase-cut dimmable using external components
- Highly flexible IC for use in buck, buck/boost modes
- Single inductor used for non-isolated configurations because of internal demagnetization detection and  $dV/dt$  supply

The IC is designed to start up directly from the HV supply using an internal high-voltage current source. An internal clamp limits the supply voltage.



## 2. Features and benefits

---

- LED driver IC for driving strings of LEDs or high-voltage LED modules from a rectified mains supply
- Power-efficient boundary conduction mode operation with:
  - ◆ No reverse recovery losses in freewheel diode
  - ◆ Zero-Current Switching (ZCS) for switch turn-on
  - ◆ Zero-voltage or valley switching for switch turn-off
  - ◆ Minimal required inductance value and size
- Fast transient response through cycle-by-cycle current control:
  - ◆ No overshoot or undershoot in the LED current
- Simple high input power factor solution ( $> 0.9$ )
- Internal protection features:
  - ◆ UnderVoltage LockOut (UVLO)
  - ◆ Leading-Edge Blanking (LEB)
  - ◆ OverCurrent Protection (OCP)
  - ◆ Internal OverTemperature Protection (OTP)
  - ◆ Brownout protection
  - ◆ Output Short Protection (OSP)
- Mains phase cut dimmable LED driver solution:
  - ◆ Supports both leading-edge and trailing-edge dimmers
  - ◆ Easy external temperature protection with a single NTC
  - ◆ Open output protection using external components
  - ◆ Compatible with wall switches with built-in indication light during standby
- IC lifetime easily matches or surpasses LED lamp lifetime
- Input current distributed evenly over the phase, reducing required output capacitor size and bleeder dissipation

## 3. Applications

---

The SSL21082AT is intended for mains dimmable compact LED lamps for single mains input voltages. Mains input voltages include 100 V (AC) and 120 V (AC).

## 4. Quick reference data

**Table 1. Quick reference data**

Symbol	Parameter	Conditions	Min	Typ	Max	Unit
V <sub>CC</sub>	supply voltage	operating range	<a href="#">[1]</a> 8	-	16	V
R <sub>DSon</sub>	drain-source on-state resistance	T <sub>j</sub> = 25 °C	2.05	2.3	2.55	Ω
		T <sub>j</sub> = 125 °C	3.05	3.45	3.85	Ω
I <sub>DRAIN</sub>	current on pin DRAIN		-2	-	+2	A
V <sub>DRAIN</sub>	voltage on pin DRAIN		-0.4	-	+300	V
f <sub>conv</sub>	conversion frequency		-	100	-	kHz

[1] An internal clamp sets the supply voltage. The current into the VCC pin must not exceed the maximum I<sub>DD</sub> value (see [Table 4](#)).

## 5. Ordering information

**Table 2. Ordering information**

Type number	Package		Version
	Name	Description	
SSL21082AT	SO12	plastic small package outline body; 12 leads; body width 3.9 mm	SOT1196-1

**6. Block diagram**

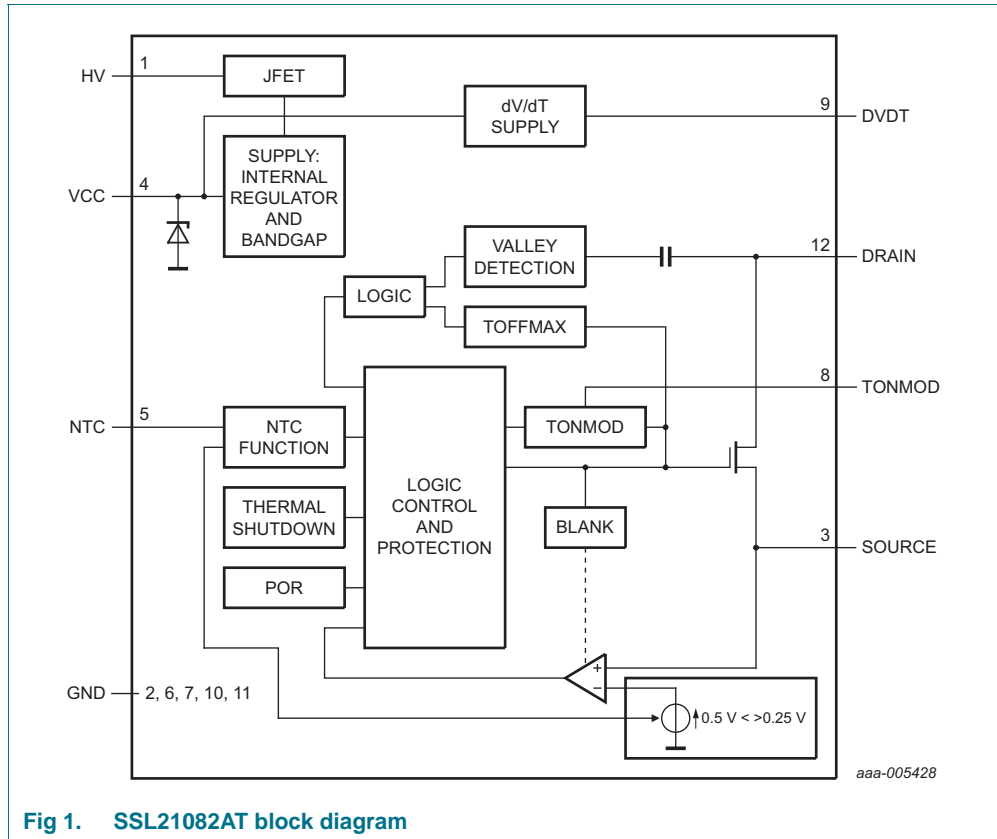

**Fig 1. SSL21082AT block diagram**

## 7. Pinning information

### 7.1 Pinning

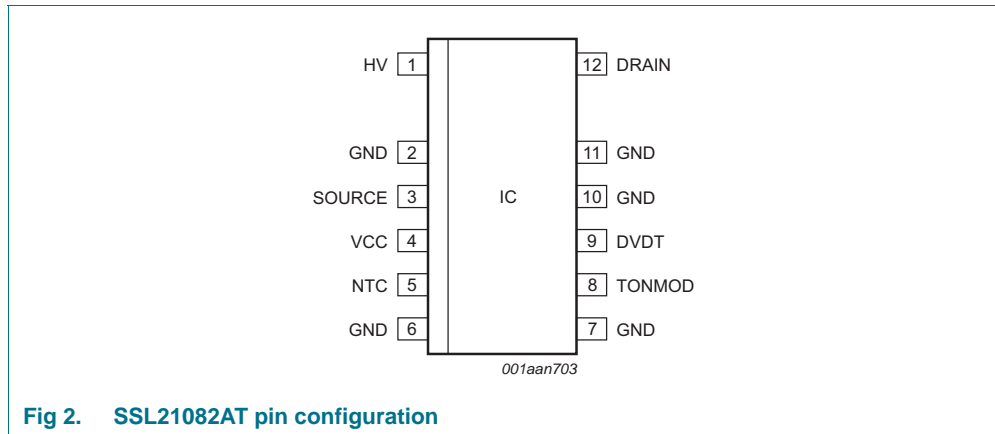

### 7.2 Pin description

Table 3. Pin description

Symbol	Pin	Description
HV	1	high-voltage supply pin
GND	2, 6, 7, 10, 11	ground
SOURCE	3	low-side external switch
VCC	4	supply voltage
NTC	5	temperature protection input
TONMOD	8	on-time modulation input
DVDT	9	AC supply pin
DRAIN	12	high-side external switch

## 8. Functional description

### 8.1 Introduction

The SSL21082AT is a controller IC solution for small form factor mains phase-cut dimmable LED lamps in isolated and non-isolated applications.

### 8.2 Converter operation

The converter in the SSL21082AT is a Boundary Conduction Mode (BCM), peak current controlled system. See [Figure 3](#) for the basic application diagram. See [Figure 4](#) for relevant the waveforms.

This converter type operates at the boundary between continuous and discontinuous mode. Energy is stored in inductor L each period that the switch is on. The inductor current  $I_L$  is zero when the MOSFET is switched on. The amplitude of the current build-up in L is proportional to the voltage drop over the inductor and the time that the MOSFET switch is on. When the MOSFET is switched off, the energy in the inductor is released towards the output. The current then falls at a rate proportional to the value of  $V_O$ . The LED current  $I_{LED}$  depends on the peak current through the inductor (SSL21082AT controlled) and on the dimmer angle while it is optimized for a high-power factor. A new cycle is started once the inductor current  $I_L$  is zero. This quasi-resonant operation results in higher efficiency.

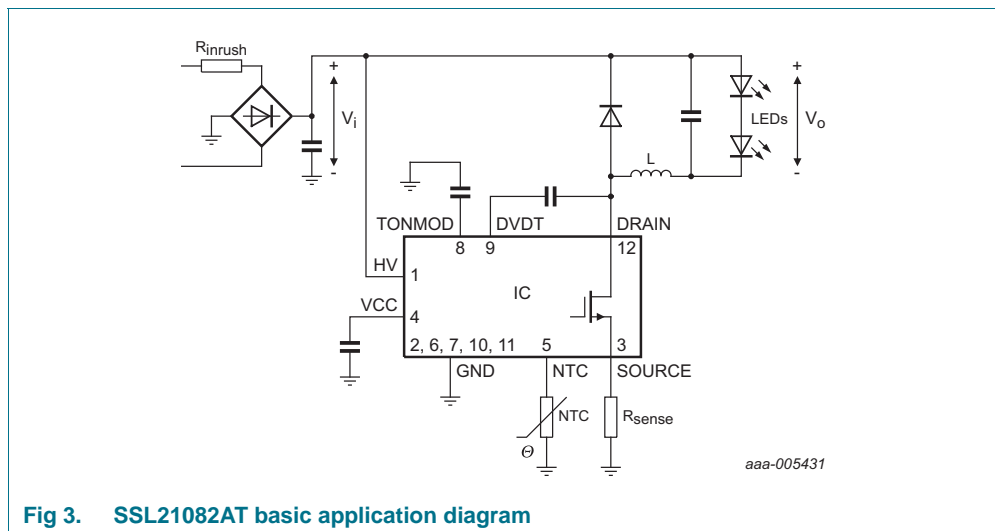

Fig 3. SSL21082AT basic application diagram

### 8.3 Valley detection

A new cycle is started when the primary switch is switched on (see Figure 4). In the following sections, “on” represents the conductive state and off the non-conductive state.

Following time  $t_1$ , when the peak current is detected on the SOURCE pin, the switch is turned off and the secondary stroke starts at  $t_2$ . When the secondary stroke is completed with the coil current at  $t_3$  equaling zero, the drain voltage starts to oscillate at approximately the  $V_i - V_O$  level. The peak-to-peak amplitude equals  $2 \times V_O$ . In a tapped buck topology, this amplitude is multiplied by the ratio of the windings.

A special feature, called valley detection is an integrated part of the SSL21082AT circuitry. Dedicated built-in circuitry connected to the DRAIN pin, senses when the voltage on the drain of the switch reaches its lowest value. The next cycle is then started at  $t_{00}$  and as a result the capacitive switching losses are reduced. If both the frequency of the oscillations and the voltage swing are within the range specified ( $f_{ring}$  and  $\Delta V_{Vrec(min)}$ ) for detection, a valley is detected and accepted. If a valid valley is not detected, the secondary stroke is continued until the maximum off-time ( $t_{off(high)}$ ) is reached. Then the next cycle is started.

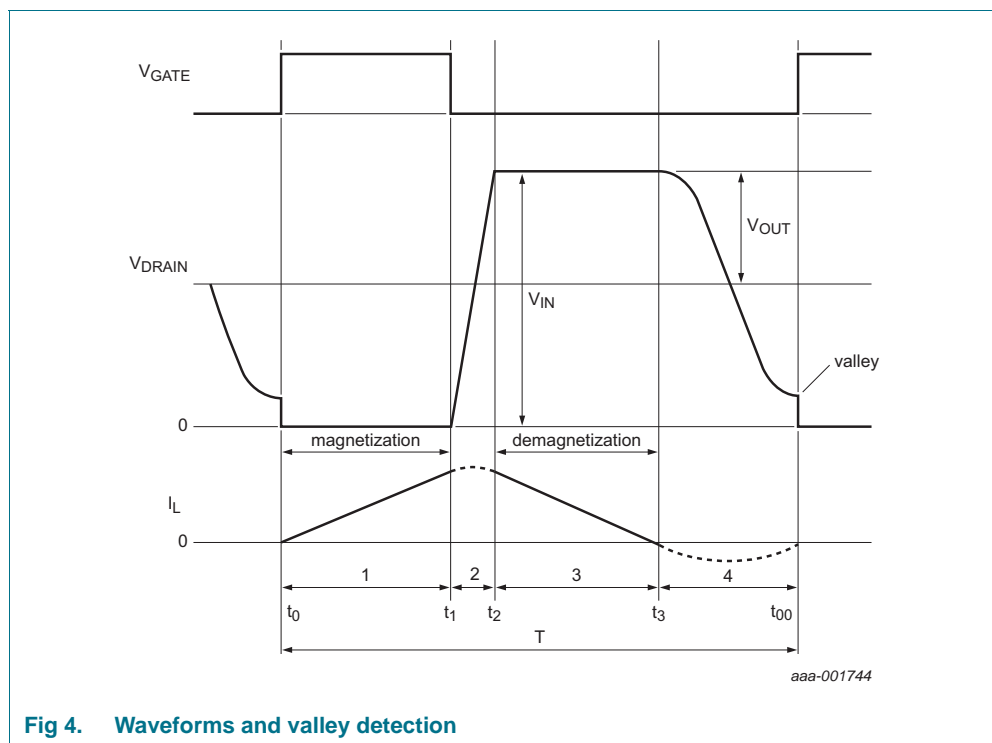

Fig 4. Waveforms and valley detection

## 8.4 Protective features

The IC has the following protective features:

- UnderVoltage LockOut (UVLO)
- Leading-Edge Blanking (LEB)
- OverCurrent Protection (OCP)
- Internal OverTemperature Protection (OTP)
- Brownout protection
- LED OverTemperature Control (OTC) and overtemperature protection
- An optional output OverVoltage Protection (OVP) circuit is implemented using external components and the NTC pin.
- Output Short Protection (OSP)

The internal OTP and LED overtemperature protections are safe-restart protections. The IC halts, causing  $V_{CC}$  to drop below  $V_{CC(stop)}$  and triggers a start-up. When  $V_{CC}$  drops to below  $V_{CC(rst)}$ , the IC resets the latch protection mode. If  $V_{CC}$  drops to below  $V_{CC(stop)}$ , the IC halts. Switching starts only when no fault condition exists.

### 8.4.1 UnderVoltage LockOut (UVLO)

When the voltage on the VCC pin  $< V_{CC(stop)}$ , the IC stops switching. An attempt is then made to restart by supplying  $V_{CC}$  from the HV pin voltage.

### 8.4.2 Leading-Edge Blanking (LEB)

To prevent false detection of the overcurrent, a blanking time following switch-on is implemented. When the MOSFET switch switches on there can be a short current spike due to capacitive discharge of voltage over the drain and source and the charging of the gate to source capacitance. During the LEB time ( $t_{leb}$ ), the spike is disregarded.

### 8.4.3 OverCurrent Protection (OCP)

The SSL21082AT contains a highly accurate peak current detector. It triggers when the voltage on the SOURCE pin reaches the peak level  $V_{th(ocp)SOURCE}$ . The current through the switch is sensed using a resistor connected to the SOURCE pin. The sense circuit is activated following LEB time  $t_{leb}$ . As the LED current is half the peak current (by design), it automatically provides protection for maximum LED current during operation. There is a propagation delay ( $t_{d(ocp-swoff)}$ ) between the overcurrent detection and the actual switching off of the switch. Due to the delay, the actual peak current is slightly higher than the OCP level set by the resistor in series to the SOURCE pin.

### 8.4.4 OverTemperature Protection (OTP)

When the internal OTP function is triggered at a certain IC temperature ( $T_{th(act)otp}$ ), the converter stops operating. The OTP safe-restart protection and the IC restart with switching resuming when the IC temperature drops below  $T_{th(rel)otp}$ .

### 8.4.5 Brownout protection

Brownout protection is designed to limit the lamp power when the input voltage drops close to the output voltage level. The input power must remain constant. The input current would otherwise increase to a level that is too large for the input circuitry. In the SSL21082AT, there is a maximum limit on the on-time of switch  $t_{on(high)}$ .

In buck mode, the rate of current rise in the coil during the on-phase is proportional to the difference between input voltage and output voltage. Therefore, the peak current cannot be reached before  $t_{on(high)}$  and as a result the average output current to the LEDs is reduced.

### 8.4.6 $t_{on}$ control

The  $t_{on(high)}$  can be lowered by connecting a capacitor to the TONMOD pin. The external capacitor is charged during the primary stroke with  $I_{offset(TONMOD)}$ . If the  $V_{th(TONMOD)}$  level is reached before the  $t_{on(high)}$  time, the switch is turned off and the secondary stroke starts. When a capacitor is not connected to the pin,  $V_{th(TONMOD)}$  is reached quickly, shorter than the minimum limit of 1  $\mu$ s. In this case or when the TONMOD pin is grounded, the internal time constant,  $t_{on(high)}$  determines the maximum on-time. This function is used to control the converter operation over the mains cycle which enables the design of a mains dimmable driver.

### 8.4.7 Output Short-circuit Protection (OSP)

During the secondary stroke (switch-off time), if a valley is not detected within the off-time limit ( $t_{off(high)}$ ), then typically the output voltage is less than the minimum limit allowed in the application. This condition can occur either during starting up or due to a short-circuit. A timer  $t_{det(sc)}$  is started when  $t_{off(high)}$  is detected. Timer  $t_{det(sc)}$  is reset when a valid valley detection occurs in one of the subsequent cycles or when  $V_{CC}$  drops below  $V_{CC(stop)}$ .

The timer can also be reset if the maximum limit on the on-time of the switch ( $t_{on(high)}$ ) is reached, which is usually the case at start-up (brownout protection). If no valley is detected and ( $t_{on(high)}$ ) is not reached before  $t_{det(sc)}$ , then it is concluded that a real short-circuit exists. The IC enters latched protection. If  $V_{CC}$  drops to below  $V_{CC(rst)}$ , the IC resets the latched protection mode (see [Figure 5](#)). During PWM dimming, the OSP timer is paused during the off cycle.

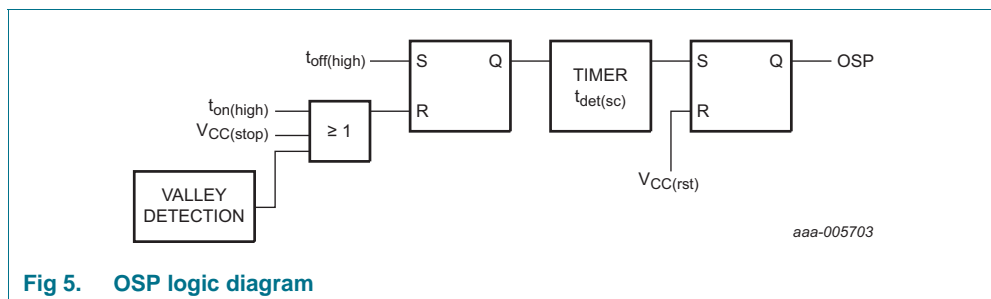

Fig 5. OSP logic diagram

The value of  $t_{on(high)}$  depends on the capacitor connected to the TONMOD pin. An open or shorted TONMOD pin sets  $t_{on(high)}$  to 15  $\mu$ s (see [Section 8.4.6](#) and [Table 6](#)).

## 8.5 VCC supply

The SSL21082AT can be supplied using three methods:

- Under normal operation, the voltage swing on the DVDT pin is internally rectified to provide current on the VCC pin
- At start-up, there is an internal current source connected to the HV pin. The current source provides internal power until either the dV/dt supply or an external current on the VCC pin provides the supply.
- Using an auxiliary winding, the voltage can be rectified and connected to the VCC pin via a series resistor.

The IC starts up when the voltage at the VCC pin exceeds  $V_{CC(\text{startup})}$ . The IC locks out (stops switching) when the voltage on the VCC pin  $< V_{CC(\text{stop})}$ . The hysteresis between the start and stop levels allows the IC to be supplied by a buffer capacitor until the external supply is stable. The SSL21082AT has an internal  $V_{CC}$  clamp, which is an internal active Zener (or shunt regulator). This internal active Zener limits the voltage on the supply VCC pin to the maximum value of  $V_{CC}$ . If the maximum current of the supply minus the current consumption of the IC (determined by the load on the gate drivers), is lower than the maximum value of  $I_{DD}$ , an external Zener diode is not required in the supply circuit.

### 8.5.1 VCC regulator

During supply dips, the input voltage can drop too low to supply the required IC current. Under these conditions, if the VCC voltage drops lower than the  $V_{CC(\text{swon})\text{reg}}$  level, a second regulator is started. Its function is to fill in the required supply current which the external supply does not deliver. It prevents that the IC goes into UVLO. When the VCC voltage exceeds  $V_{CC(\text{swon})\text{reg}}$  level, the regulator is turned off.

## 8.6 DVDT pin supply (dV/dt)

The DVDT pin is connected to an internal single-sided rectification stage. When an alternating voltage with sufficient amplitude is supplied to this pin, the IC can be powered without another external power connection. This provides a compact and effective solution without introducing high power losses and without requiring an additional inductor winding.

## 8.7 NTC functionality and PWM dimming

The NTC pin can be used as a control method for LED thermal protection. Alternatively, the pin can be used as an input to disable/enable light output using a digital signal (PWM dimming). The pin has an internal current source that generates the current of  $I_{\text{offset(NTC)}}$ . An NTC resistor to monitor the LED temperature can be directly connected to the NTC pin. Depending on the resistance value and the corresponding voltage on the NTC pin, the converter reacts as shown in [Figure 6](#).

During start-up, before  $V_{CC}$  reaches  $V_{CC(\text{startup})}$  the voltage on the NTC pin must be less than the minimum value of  $V_{\text{act}(t_{\text{mr}})\text{NTC}}$ . This is valid when the voltage on the NTC pin is derived from the  $V_{CC}$  using a resistive divider and a PTC in series with the resistor between pins VCC and NTC.

If an NTC resistor is connected between the NTC pin and ground, the voltage on the NTC pin is 0 V when  $V_{CC}$  reaches  $V_{CC(\text{startup})}$ .

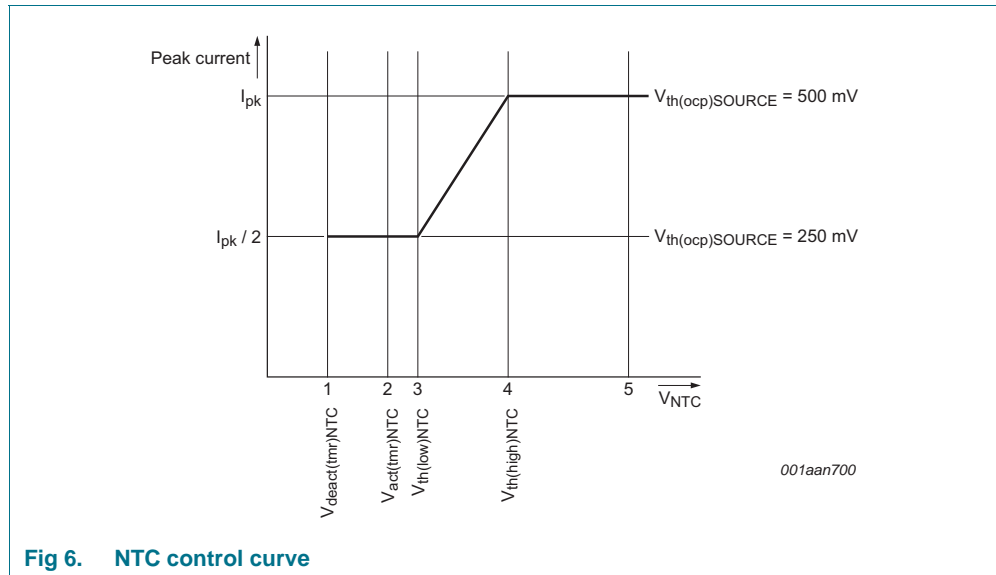

**Fig 6. NTC control curve**

When the voltage on the NTC pin exceeds  $V_{th(high)NTC}$  (see [Figure 6 \(4\)](#)), the converter delivers nominal output current. When the voltage is lower than this level, the peak current is gradually reduced until  $V_{th(low)NTC}$  is reached (see [Figure 6 \(3\)](#)). The peak current is now half the peak current of nominal operation. When  $V_{act(tmr)NTC}$  is passed (see [Figure 6 \(2\)](#)) a timer starts to run to distinguish between the following situations:

- If the low-level  $V_{deact(tmr)NTC}$  is not reached within time  $t_{to(deact)NTC}$  (see [Figure 6 \(1\)](#)) LED overtemperature is detected. The IC stops switching and attempts to restart from the HV pin voltage. The converter restarts from an NTC protection shutdown when the voltage on the NTC pin exceeds  $V_{th(high)NTC}$  (see [Figure 6 \(4\)](#)). It is assumed that the reduction in peak current does not result in a lower NTC temperature and LED OTP is activated.
- If the low-level  $V_{deact(tmr)NTC}$  is reached within the time  $t_{to(deact)NTC}$  (see [Figure 6 \(1\)](#)) it is assumed that the pin is pulled down externally. The restart function is not triggered. Instead, the output current is reduced to zero. PWM dimming can be implemented this way. The output current rises again when the voltage is higher than  $V_{th(low)NTC}$ .

### 8.7.1 Soft-start function

The NTC pin can be used to make a soft start function. During switch-on, the level on the NTC pin is low. By connecting a capacitor (in parallel with the NTC resistor), a time constant can be defined. The time constant causes the level on the NTC pin to increase slowly. When passing level  $V_{th(low)NTC}$  (see [Figure 6 \(3\)](#)), the converter starts with half of the maximum current. The output current slowly increases to maximum when  $V_{th(high)NTC}$  (see [Figure 6 \(4\)](#)) is reached.

## 8.8 Heat sink

In SSL21082AT applications, the PCB copper acts as the heat sink. The IC has thermal leads (GND pins 2, 6, 10 and 11) for enhanced heat transfer from die to the PCB copper heat sink. The thermal lead connection can drastically reduce thermal resistance.

[Equation 1](#) shows the relationship between the maximum allowable power dissipation and the thermal resistance from junction to ambient.

$$R_{th(j-a)} = \frac{(T_{j(max)} - T_{amb})}{P} \quad (1)$$

Where:

$R_{th(j-a)}$  = thermal resistance from junction to ambient

$T_{j(max)}$  = maximum junction temperature

$T_{amb}$  = ambient temperature

P = Power dissipation

## 9. Limiting values

**Table 4. Limiting values**

*In accordance with the Absolute Maximum Rating System (IEC 60134).*

Symbol	Parameter	Conditions	Min	Max	Unit
<b>General</b>					
SR	slew rate	on pin DRAIN	-5	+5	V/ns
P <sub>tot</sub>	total power dissipation	SO12 package	-	1	W
T <sub>amb</sub>	ambient temperature		-40	+125	°C
T <sub>j</sub>	junction temperature		-40	+150	°C
T <sub>stg</sub>	storage temperature		-55	+150	°C
<b>Voltages</b>					
V <sub>CC</sub>	supply voltage	continuous	[1] -0.4	+20	V
V <sub>DRAIN</sub>	voltage on pin DRAIN		-0.4	+300	V
V <sub>HV</sub>	voltage on pin HV	current limited	-0.4	+600	V
V <sub>SOURCE</sub>	voltage on pin SOURCE	current limited	-0.4	+5.2	V
V <sub>NTC</sub>	voltage on pin NTC	current limited	-0.4	+5.2	V
V <sub>TONMOD</sub>	voltage on pin TONMOD	current limited	-0.4	+5.2	V
<b>Currents</b>					
I <sub>DD</sub>	supply current	on pin VCC	[2] -	20	mA
I <sub>DRAIN</sub>	current on pin DRAIN		-2	+2	A
I <sub>SOURCE</sub>	current on pin SOURCE		-2	+2	A
I <sub>DVTD</sub>	current on pin DVDT	duration 20 μs maximum	-	1.3	A
<b>Electrostatic discharge</b>					
V <sub>ESD</sub>	electrostatic discharge voltage	human body model; pins DRAIN and HV	-1	+1	kV
		human body model; all other pins	[3] -2	+2	kV
		charged device	[4] -500	+500	V

[1] The current flowing into the VCC pin must not exceed the maximum I<sub>DD</sub> value.

[2] An internal clamp sets the supply voltage.

[3] Human body model: equivalent to discharging a 100 pF capacitor through a 1.5 kΩ series resistor.

[4] Charged device model: equivalent to charging the IC up to 1 kV and the subsequent discharging of each pin down to 0 V over a 1 Ω resistor.

## 10. Thermal characteristics

**Table 5. Thermal characteristics**

Symbol	Parameter	Conditions	Typ	Unit
$R_{th(j-a)}$	thermal resistance from junction to ambient	in free air; PCB: 2 cm × 3 cm; 2-layer; 35 μm Cu per layer	121	K/W
		in free air; PCB: JEDEC 2s2p	53	K/W
$\Psi_{j-top}$	thermal characterization parameter from junction to top of package	top package temperature measured at the warmest point on top of the case	3.4	K/W

## 11. Characteristics

**Table 6. Characteristics**

Values specified at  $T_{amb} = 25\text{ °C}$  unless otherwise specified; all voltages are measured with respect to ground; currents are positive when flowing into the IC.

Symbol	Parameter	Conditions	Min	Typ	Max	Unit
$f_{conv}$	conversion frequency		-	100	-	kHz
<b>High-voltage</b>						
$I_{leak(DRAIN)}$	leakage current on pin DRAIN	$V_{DRAIN} = 300\text{ V}$	-	-	10	μA
$I_{leak(HV)}$	leakage current on pin HV	$V_{HV} = 300\text{ V}$	-	-	30	μA
<b>Supply</b>						
$V_{CC}$	supply voltage	operating range	<a href="#">11</a> 8	-	16	V
$V_{CC(startup)}$	start-up supply voltage		11	12	13	V
$V_{CC(stop)}$	stop supply voltage		8	9	10	V
$V_{CC(hys)}$	hysteresis of supply voltage	between $V_{CC(startup)}$ and $V_{CC(stop)}$	2	-	4.5	V
$V_{CC(rst)}$	reset supply voltage		4.5	5	5.5	V
$V_{CC(swon)reg}$	regulator switch-on supply voltage		8.75	9.25	9.75	V
$V_{CC(swoff)reg}$	regulator switch-off supply voltage		9.5	10	10.5	V
$V_{CC(reg)hys}$	regulator supply voltage hysteresis	$V_{CC(swoff)reg} - V_{CC(swon)reg}$	0.3	-	-	V
$V_{CC(regswon-stop)}$	supply voltage difference between regulator switch-on and stop	$V_{CC(swon)reg} - V_{CC(stop)}$	0.3	-	-	V
<b>Consumption</b>						
$I_{stb(HV)}$	standby current on pin HV	during start-up or in protection; $V_{HV} = 100\text{ V}$	300	350	400	μA
$I_{CC(INT)}$	internal supply current	normal operation	-	1.3	-	mA
<b>Capability</b>						
$I_{sup(high)HV}$	high supply current on pin HV	Standby: $V_{HV} = 40\text{ V}$ ; $V_{CC} < V_{CC(stop)}$	1	1.3	1.6	mA
		Regulator on: $V_{HV} = 40\text{ V}$ ; $V_{CC} < V_{CC(swon)reg}$ after start-up	2	2.3	2.6	mA

**Table 6. Characteristics ...continued**

Values specified at  $T_{amb} = 25\text{ °C}$  unless otherwise specified; all voltages are measured with respect to ground; currents are positive when flowing into the IC.

Symbol	Parameter	Conditions	Min	Typ	Max	Unit
<b>Current protection</b>						
$V_{th(ocp)SOURCE}$	overcurrent protection threshold voltage on pin SOURCE	$\Delta V/\Delta t = 0.1\text{ V}/\mu\text{s}$	480	500	520	mV
		$\Delta V/\Delta t = 0.1\text{ V}/\mu\text{s}; V_{NTC} = 0.325\text{ V}$	230	250	270	mV
$t_{d(ocp-swoff)}$	delay time from overcurrent protection to switch-off	$\Delta V/\Delta t = 0.1\text{ V}/\mu\text{s}$	-	75	100	ns
$t_{leb}$	leading edge blanking time	overcurrent protection	260	300	340	ns
<b>Valley detection</b>						
$(\Delta V/\Delta t)_{vrec}$	valley recognition voltage change with time	on pin DRAIN	-30	-20	-10	V/ $\mu\text{s}$
$f_{ring}$	ringing frequency		[2] 200	550	1000	kHz
$\Delta V_{vrec(min)}$	minimum valley recognition voltage difference	voltage drop on pin DRAIN	15	20	25	V
$t_{d(vrec-swon)}$	valley recognition to switch-on delay time		-	100	-	ns
<b>Brownout detection</b>						
$V_{th(TONMOD)}$	threshold voltage on pin TONMOD		3.75	4	4.25	V
$I_{offset(TONMOD)}$	offset current on pin TONMOD		-37	-43	-48	$\mu\text{A}$
$t_{on(high)}$	high on-time		12.5	15	17.5	$\mu\text{s}$
<b>MOSFET output stage</b>						
$V_{BR(DRAIN)}$	breakdown voltage on pin DRAIN	$T_j > 0\text{ °C}$	300	-	-	V
$R_{DSon}$	drain-source on-state resistance	$T_j = 25\text{ °C}$	2.05	2.3	2.55	$\Omega$
		$T_j = 125\text{ °C}$	3.05	3.45	3.85	$\Omega$
$(dV/dt)_f(DRAIN)$	fall rate of change of voltage on pin DRAIN	$C_{DRAIN} = 150\text{ pF}; R_{SOURCE} = 2.2\text{ }\Omega$	-	1.2	-	V/ns
<b>NTC functionality</b>						
$V_{th(high)NTC}$	high threshold voltage on pin NTC		0.47	0.5	0.53	V
$V_{th(low)NTC}$	low threshold voltage on pin NTC		0.325	0.35	0.375	V
$V_{act(tmr)NTC}$	timer activation voltage on pin NTC		0.26	0.3	0.325	V
$V_{deact(tmr)NTC}$	timer deactivation voltage on pin NTC		0.17	0.2	0.23	V
$t_{to(deact)NTC}$	deactivation time-out time on pin NTC		33	46	59	$\mu\text{s}$
$I_{offset(NTC)}$	offset current on pin NTC		-	-47	-	$\mu\text{A}$
<b>Temperature protection</b>						
$T_{th(act)otp}$	overtemperature protection activation threshold temperature		160	170	180	$^{\circ}\text{C}$
$T_{th(rel)otp}$	overtemperature protection release threshold temperature		90	100	110	$^{\circ}\text{C}$

[1] An internal clamp sets the supply voltage. The current into the VCC pin must not exceed the maximum  $I_{DD}$  value (see [Table 4](#)).

[2] This parameter is not tested during production. It is guaranteed by design.

## 12. Package outline

SO12: plastic small outline package; 12 leads; body width 3.9 mm

SOT1196-1

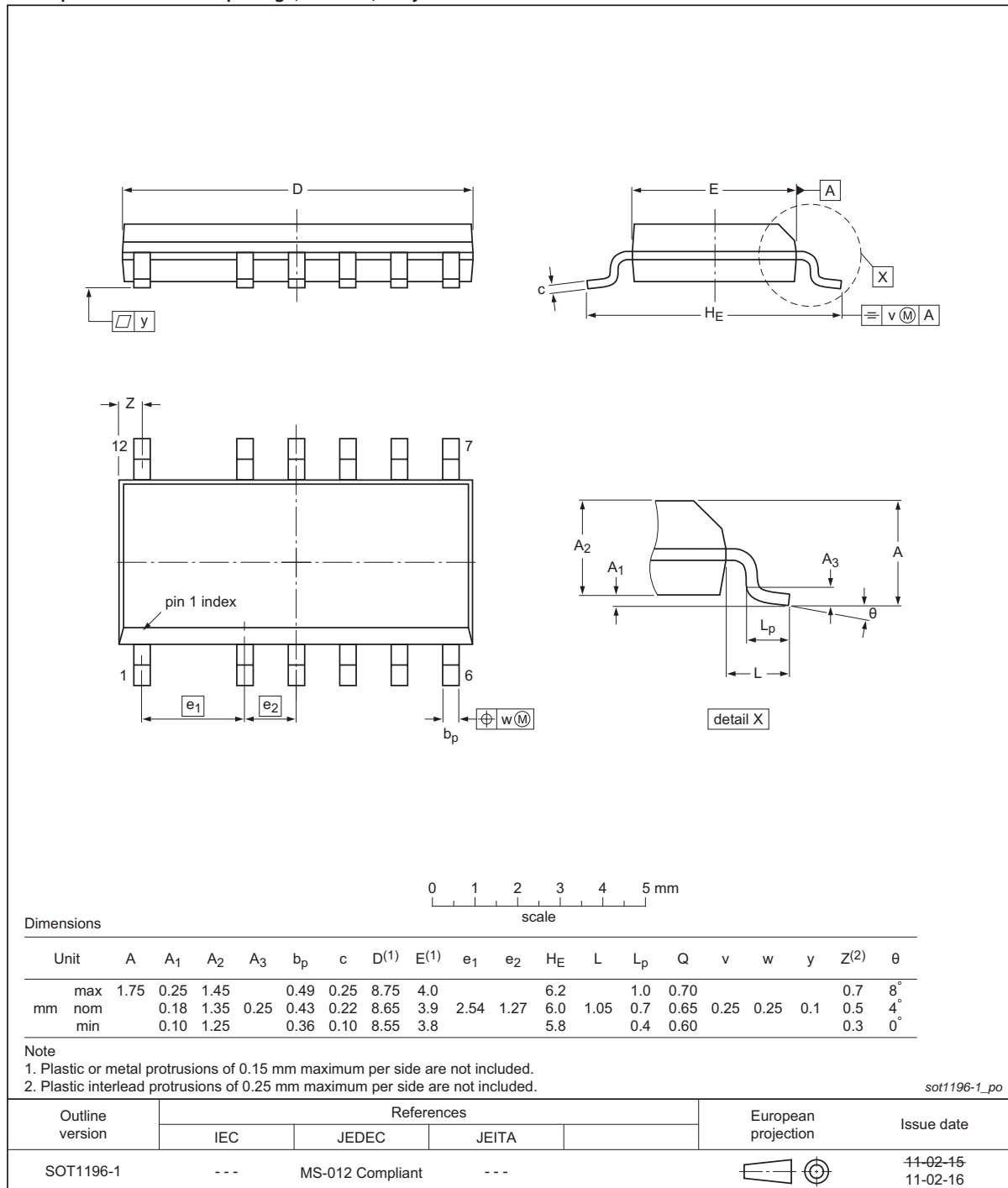

Fig 7. Package outline SOT1196-1 (SO12)

## 13. Abbreviations

---

Table 7. Abbreviations

Acronym	Description
BCM	Boundary Conduction Mode
LEB	Leading-Edge Blanking
LED	Light Emitting Diode
MOSFET	Metal-Oxide Semiconductor Field-Effect Transistor
OCP	OverCurrent Protection
OTP	OverTemperature Protection
PCB	Printed-Circuit Board
PWM	Pulse-Width Modulation
TVS	Transient Voltage Suppression
UVLO	UnderVoltage LockOut
ZCS	Zero-Current Switching

## 14. References

---

- [1] **AN11041** — SSL21081, SSL21083, and SSL2109 non-dimmable buck converter in low ripple configurations
- [2] **AN11263** — 230 V (AC) mains dimmable LED driver using the SSL2129AT or SSL21084AT

## 15. Revision history

**Table 8.** Revision history

Document ID	Release date	Data sheet status	Change notice	Supersedes
SSL21082AT v.6	20131003	Product data sheet	-	SSL21082_SSL21084 v.5
Modifications:	<ul style="list-style-type: none"> <li>Text and drawings have been updated throughout the data sheet.</li> </ul>			
SSL21082_SSL21084 v.5	20121214	Product data sheet	-	SSL2108_SER v.4
SSL2108_SER v.4	20120508	Product data sheet	-	SSL21081T_2T_3T_4T v.3.1
SSL21081T_2T_3T_4T v.3.1	20120222	Product data sheet	-	SSL21081T_2T_3T_4T v.3
SSL21081T_2T_3T_4T v.3	20120214	Product data sheet	-	SSL21081T_2T_3T_4T v.2
SSL21081T_2T_3T_4T v.2	20111206	Preliminary data sheet	-	SSL2108X v.1
SSL2108X v.1	20110909	Preliminary data sheet	-	-

## 16. Legal information

### 16.1 Data sheet status

Document status <sup>[1][2]</sup>	Product status <sup>[3]</sup>	Definition
Objective [short] data sheet	Development	This document contains data from the objective specification for product development.
Preliminary [short] data sheet	Qualification	This document contains data from the preliminary specification.
Product [short] data sheet	Production	This document contains the product specification.

[1] Please consult the most recently issued document before initiating or completing a design.

[2] The term 'short data sheet' is explained in section "Definitions".

[3] The product status of device(s) described in this document may have changed since this document was published and may differ in case of multiple devices. The latest product status information is available on the Internet at URL <http://www.nxp.com>.

### 16.2 Definitions

**Draft** — The document is a draft version only. The content is still under internal review and subject to formal approval, which may result in modifications or additions. NXP Semiconductors does not give any representations or warranties as to the accuracy or completeness of information included herein and shall have no liability for the consequences of use of such information.

**Short data sheet** — A short data sheet is an extract from a full data sheet with the same product type number(s) and title. A short data sheet is intended for quick reference only and should not be relied upon to contain detailed and full information. For detailed and full information see the relevant full data sheet, which is available on request via the local NXP Semiconductors sales office. In case of any inconsistency or conflict with the short data sheet, the full data sheet shall prevail.

**Product specification** — The information and data provided in a Product data sheet shall define the specification of the product as agreed between NXP Semiconductors and its customer, unless NXP Semiconductors and customer have explicitly agreed otherwise in writing. In no event however, shall an agreement be valid in which the NXP Semiconductors product is deemed to offer functions and qualities beyond those described in the Product data sheet.

### 16.3 Disclaimers

**Limited warranty and liability** — Information in this document is believed to be accurate and reliable. However, NXP Semiconductors does not give any representations or warranties, expressed or implied, as to the accuracy or completeness of such information and shall have no liability for the consequences of use of such information. NXP Semiconductors takes no responsibility for the content in this document if provided by an information source outside of NXP Semiconductors.

In no event shall NXP Semiconductors be liable for any indirect, incidental, punitive, special or consequential damages (including - without limitation - lost profits, lost savings, business interruption, costs related to the removal or replacement of any products or rework charges) whether or not such damages are based on tort (including negligence), warranty, breach of contract or any other legal theory.

Notwithstanding any damages that customer might incur for any reason whatsoever, NXP Semiconductors' aggregate and cumulative liability towards customer for the products described herein shall be limited in accordance with the *Terms and conditions of commercial sale* of NXP Semiconductors.

**Right to make changes** — NXP Semiconductors reserves the right to make changes to information published in this document, including without limitation specifications and product descriptions, at any time and without notice. This document supersedes and replaces all information supplied prior to the publication hereof.

**Suitability for use** — NXP Semiconductors products are not designed, authorized or warranted to be suitable for use in life support, life-critical or safety-critical systems or equipment, nor in applications where failure or malfunction of an NXP Semiconductors product can reasonably be expected to result in personal injury, death or severe property or environmental damage. NXP Semiconductors and its suppliers accept no liability for inclusion and/or use of NXP Semiconductors products in such equipment or applications and therefore such inclusion and/or use is at the customer's own risk.

**Applications** — Applications that are described herein for any of these products are for illustrative purposes only. NXP Semiconductors makes no representation or warranty that such applications will be suitable for the specified use without further testing or modification.

Customers are responsible for the design and operation of their applications and products using NXP Semiconductors products, and NXP Semiconductors accepts no liability for any assistance with applications or customer product design. It is customer's sole responsibility to determine whether the NXP Semiconductors product is suitable and fit for the customer's applications and products planned, as well as for the planned application and use of customer's third party customer(s). Customers should provide appropriate design and operating safeguards to minimize the risks associated with their applications and products.

NXP Semiconductors does not accept any liability related to any default, damage, costs or problem which is based on any weakness or default in the customer's applications or products, or the application or use by customer's third party customer(s). Customer is responsible for doing all necessary testing for the customer's applications and products using NXP Semiconductors products in order to avoid a default of the applications and the products or of the application or use by customer's third party customer(s). NXP does not accept any liability in this respect.

**Limiting values** — Stress above one or more limiting values (as defined in the Absolute Maximum Ratings System of IEC 60134) will cause permanent damage to the device. Limiting values are stress ratings only and (proper) operation of the device at these or any other conditions above those given in the Recommended operating conditions section (if present) or the Characteristics sections of this document is not warranted. Constant or repeated exposure to limiting values will permanently and irreversibly affect the quality and reliability of the device.

**Terms and conditions of commercial sale** — NXP Semiconductors products are sold subject to the general terms and conditions of commercial sale, as published at <http://www.nxp.com/profile/terms>, unless otherwise agreed in a valid written individual agreement. In case an individual agreement is concluded only the terms and conditions of the respective agreement shall apply. NXP Semiconductors hereby expressly objects to applying the customer's general terms and conditions with regard to the purchase of NXP Semiconductors products by customer.

**No offer to sell or license** — Nothing in this document may be interpreted or construed as an offer to sell products that is open for acceptance or the grant, conveyance or implication of any license under any copyrights, patents or other industrial or intellectual property rights.

**Export control** — This document as well as the item(s) described herein may be subject to export control regulations. Export might require a prior authorization from competent authorities.

**Quick reference data** — The Quick reference data is an extract of the product data given in the Limiting values and Characteristics sections of this document, and as such is not complete, exhaustive or legally binding.

**Non-automotive qualified products** — Unless this data sheet expressly states that this specific NXP Semiconductors product is automotive qualified, the product is not suitable for automotive use. It is neither qualified nor tested in accordance with automotive testing or application requirements. NXP Semiconductors accepts no liability for inclusion and/or use of non-automotive qualified products in automotive equipment or applications.

In the event that customer uses the product for design-in and use in automotive applications to automotive specifications and standards, customer (a) shall use the product without NXP Semiconductors' warranty of the product for such automotive applications, use and specifications, and (b)

whenever customer uses the product for automotive applications beyond NXP Semiconductors' specifications such use shall be solely at customer's own risk, and (c) customer fully indemnifies NXP Semiconductors for any liability, damages or failed product claims resulting from customer design and use of the product for automotive applications beyond NXP Semiconductors' standard warranty and NXP Semiconductors' product specifications.

**Translations** — A non-English (translated) version of a document is for reference only. The English version shall prevail in case of any discrepancy between the translated and English versions.

## 16.4 Trademarks

Notice: All referenced brands, product names, service names and trademarks are the property of their respective owners.

**GreenChip** — is a trademark of NXP B.V.

## 17. Contact information

For more information, please visit: <http://www.nxp.com>

For sales office addresses, please send an email to: [salesaddresses@nxp.com](mailto:salesaddresses@nxp.com)

## 18. Contents

<b>1</b>	<b>General description</b> . . . . .	<b>1</b>
<b>2</b>	<b>Features and benefits</b> . . . . .	<b>2</b>
<b>3</b>	<b>Applications</b> . . . . .	<b>2</b>
<b>4</b>	<b>Quick reference data</b> . . . . .	<b>3</b>
<b>5</b>	<b>Ordering information</b> . . . . .	<b>3</b>
<b>6</b>	<b>Block diagram</b> . . . . .	<b>4</b>
<b>7</b>	<b>Pinning information</b> . . . . .	<b>5</b>
7.1	Pinning . . . . .	5
7.2	Pin description . . . . .	5
<b>8</b>	<b>Functional description</b> . . . . .	<b>6</b>
8.1	Introduction . . . . .	6
8.2	Converter operation . . . . .	6
8.3	Valley detection . . . . .	7
8.4	Protective features . . . . .	8
8.4.1	UnderVoltage LockOut (UVLO) . . . . .	8
8.4.2	Leading-Edge Blanking (LEB) . . . . .	8
8.4.3	OverCurrent Protection (OCP) . . . . .	8
8.4.4	OverTemperature Protection (OTP) . . . . .	8
8.4.5	Brownout protection . . . . .	9
8.4.6	t <sub>on</sub> control . . . . .	9
8.4.7	Output Short-circuit Protection (OSP) . . . . .	9
8.5	VCC supply . . . . .	10
8.5.1	VCC regulator . . . . .	10
8.6	DVDT pin supply (dV/dt) . . . . .	10
8.7	NTC functionality and PWM dimming . . . . .	10
8.7.1	Soft-start function . . . . .	11
8.8	Heat sink . . . . .	12
<b>9</b>	<b>Limiting values</b> . . . . .	<b>13</b>
<b>10</b>	<b>Thermal characteristics</b> . . . . .	<b>14</b>
<b>11</b>	<b>Characteristics</b> . . . . .	<b>14</b>
<b>12</b>	<b>Package outline</b> . . . . .	<b>16</b>
<b>13</b>	<b>Abbreviations</b> . . . . .	<b>17</b>
<b>14</b>	<b>References</b> . . . . .	<b>17</b>
<b>15</b>	<b>Revision history</b> . . . . .	<b>18</b>
<b>16</b>	<b>Legal information</b> . . . . .	<b>19</b>
16.1	Data sheet status . . . . .	19
16.2	Definitions . . . . .	19
16.3	Disclaimers . . . . .	19
16.4	Trademarks . . . . .	20
<b>17</b>	<b>Contact information</b> . . . . .	<b>20</b>
<b>18</b>	<b>Contents</b> . . . . .	<b>21</b>

Please be aware that important notices concerning this document and the product(s) described herein, have been included in section 'Legal information'.

© NXP B.V. 2013.

All rights reserved.

For more information, please visit: <http://www.nxp.com>

For sales office addresses, please send an email to: [salesaddresses@nxp.com](mailto:salesaddresses@nxp.com)

Date of release: 3 October 2013

Document identifier: SSL21082AT

## Looking for pricing, stock, or lifecycle information?

Click below to explore more details on WIN SOURCE:

 [View SSL21082AT/1,118 on WIN SOURCE](#)

 [NXP / Nexperia Information](#)

## Optimize Your Supply Chain with WIN SOURCE Solutions

-  Global Sourcing Solution
-  Obsolete Management
-  Cost Control Management
-  Shortage Management
-  Alternative Solution
-  Excess Inventory Management