

---

## Developing Embedded Graphics Applications using PIC<sup>®</sup> Microcontrollers with Integrated Graphics Controller

---

*Author: Pradeep Budagutta  
Microchip Technology Inc.*

### INTRODUCTION

Graphic-enabled devices are used extensively in daily life. They are found everywhere, including indoor products, such as telephones, calculators, pagers, MP3 players, digital electric meters, smart remote and UPS displays. They are also used in outdoor products, such as traffic signals, taxi meters, bus displays, advertisement boards, etc. The list is virtually endless. A current trend is that many existing devices are becoming graphic-enabled because it is economically feasible, easy to use and the latest in technology.

This application note is intended to help engineers who are designing their first graphic application. It describes the basic definitions and jargons of graphics applications and it helps the engineer to understand the theory, necessary decision factors, hardware considerations, available microcontrollers and development tools. Software libraries and support are available from Microchip with further literature references for advanced users.

### BASICS OF COLOR SCIENCE

In its purest form, color is associated with the wavelength of light, within human visible range, from about 400 nm (Violet) to 700 nm (Red), with Yellow centered at about 575 nm. That means, if a light of 575 nm wavelength is incident on human eyes, it is perceived as a Yellow light. We have also learned that colors can be derived from three basic colors: Red, Blue and Green. For example, Yellow can be derived by mixing Red and Green lights. Is this true? The answer is both no and yes. It is no because mixing Red and Green lights will constitute a mixture of lights with wavelengths of 700 nm and 560 nm, and there is not a wavelength representing Yellow. The answer is yes because human eyes perceive this mixture as a Yellow colored light. Therefore, we see the mixture of Red and Green lights as a single Yellow light, as shown in [Figure 1](#). This is due to the color recognition properties of the human eye.

**FIGURE 1: RED + GREEN = YELLOW**



Human eyes perceive the light as a Yellow colored light instead of separate Red and Green colored lights. This color recognition property of the human eye is the foundation of the RGB (Red, Green and Blue) model. The model states that the human eye can be made to perceive different colors by mixing appropriate proportions (intensities) of Red, Blue and Green colors. Therefore, a 'colored' light can be formed by mixing different proportions of Red, Green and Blue colors.

- Mixing the same proportions of three RGB colors gives a Gray color
- Mixing a zero amount of all RGB colors gives a Black color
- Mixing a maximum amount of all RGB colors gives a White color

Varying the intensity of light, while keeping the same proportion of RGB, gives different shades of Gray, which is also known as 'Grayscale'. Using a single color (a fixed proportion of RGB) throughout an application gives a 'Monochrome' application, meaning a single color.

Since everything is represented in bits and bytes in a digital system, then how can actual colors be represented as a number in the form of bits or bytes? Each of these three basic colors (RGB) can represent a byte for a number ranging from 0 to 255. Therefore, with 3 bytes, we can represent 16 million colors ( $2^{24}$ ) and this is termed as "True Color". It is also common to use 16 bits to represent colors. With 16 bits, we can represent 64K colors ( $2^{16}$ ), which is sufficient for many graphics applications.

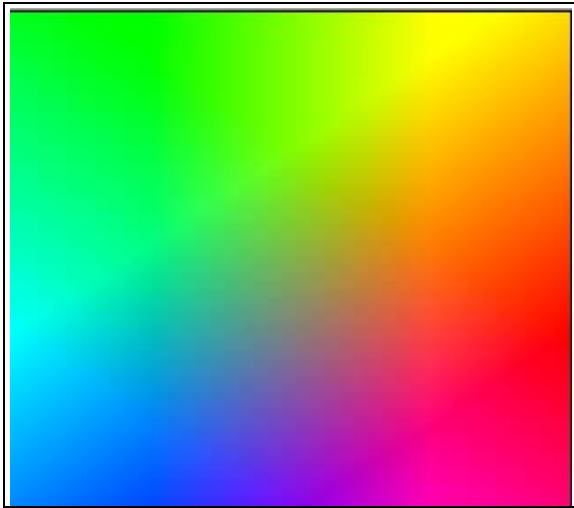
# AN1368

In general, to divide 16 bits among Red, Green and Blue, two schemes are used:

- **Scheme 1 (R<5> G<6> B<5>):** In this scheme, there are 5 bits of Red, followed by 6 bits of Green and 5 bits of Blue. Green is given more bits because of the property of the human eye, which can distinguish more shades of Green than Red and Blue. [Figure 2](#) illustrates these 64K colors.
- **Scheme 2 (T<1> R<5> G<5> B<5>):** In this scheme, there is one transparent bit, followed by 5 bits each of Red, Green and Blue. The transparent bit indicates if the color should be used or not.

Currently, the Microchip Graphics Library (Version 2.11) supports only Scheme 1.

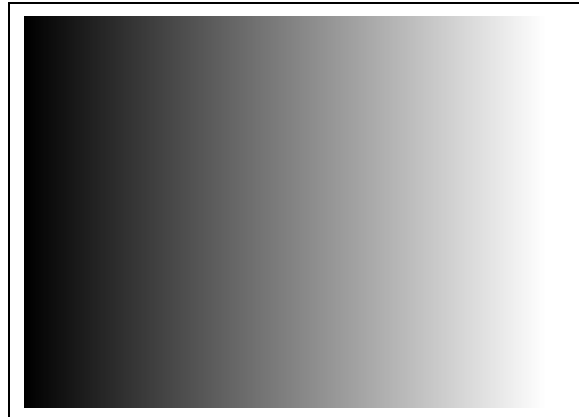
**FIGURE 2: COLORS IN 16-BIT REPRESENTATION**



Grayscale is usually represented in a byte, with 0 as Black, 1-254 as the shades of Black, getting lighter as the number increases, and 255 as White, as shown in [Figure 3](#). Sometimes, only 4 or 2 bits are used to represent 16 or 4 shades of Black, respectively. If only one bit is used to represent either the on or off of a color, then it is called 'Monochrome'.

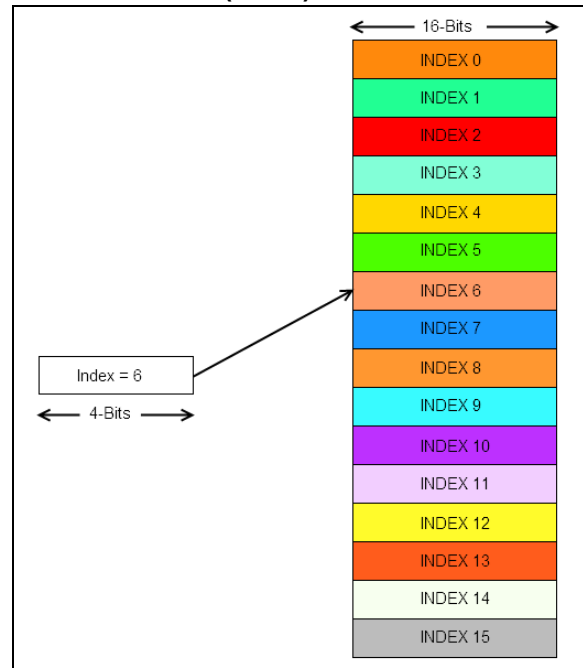
The number of bits required to represent a color is called the 'Color Depth'. For example, a color depth of 16 bits means it requires 16 bits to represent a color, and therefore, we can represent  $2^{16}$  different colors.

**FIGURE 3: GRAYSCALE VALUES OF 0 TO 225**



Alternatively, color may be represented using a Color Look-up Table (CLUT), also called a palette table, where the color is specified by the index of the table, as shown in [Figure 4](#). Depending on the size of the table, the bits used to represent the index will vary as 256 entries of RGB (8-bit index), 16 entries of RGB (4-bit index), 4 entries of RGB (2-bit index) and 2 entries of RGB (1-bit index). This scheme is mainly used to save memory. For more information on this scheme, see [Appendix A: "Color Look-up Table \(CLUT\)"](#).

**FIGURE 4: COLOR LOOK-UP TABLE (CLUT)**



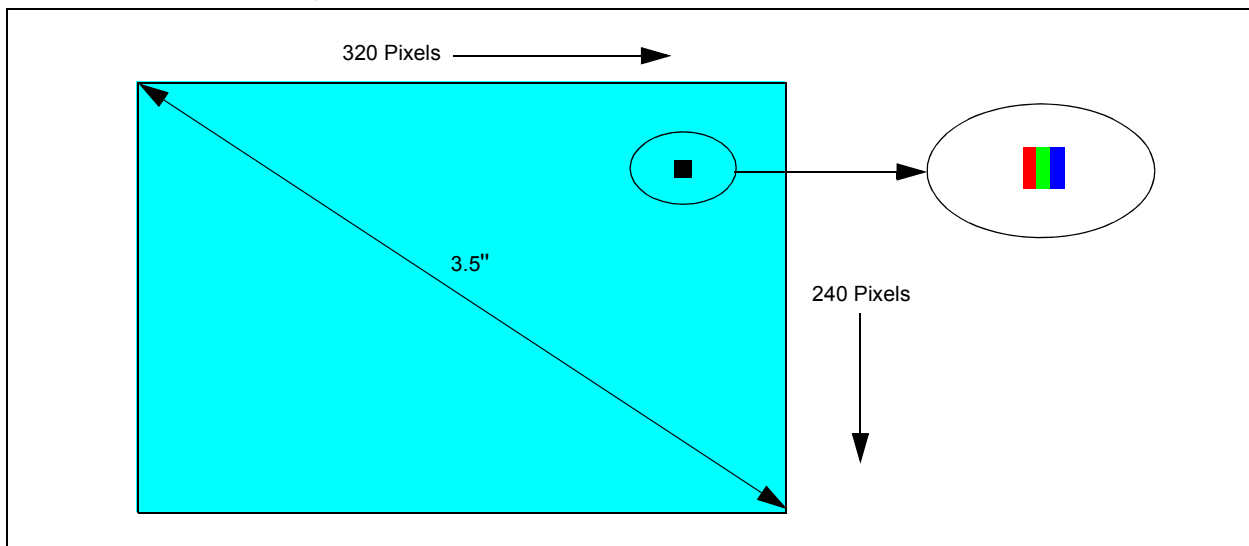
## BASIC DISPLAY TERMINOLOGY

A screen is made up of discrete elements, known as pixels. Every pixel can show one point of color and each pixel is composed of three points: Red, Green and Blue. The colors are arranged next to each other on a color screen, one point of intensity on a grayscale screen or one point that can be set to on/off on a monochrome screen. The number of such pixels in horizontal and vertical directions is called the screen resolution. For example, a resolution of 320x240 means there are 320 pixels horizontally (number of columns) and 240 pixels vertically (number of rows). Standard resolutions are given names, such as QCIF (176x144), CIF (352x288), QVGA (320x240), WQVGA (480x272), VGA (640x480) and WVGA (800x480), etc. While mentioning the resolution, it is always better to refer to the numbers instead of the names.

A screen can be in Landscape mode (width > height) or in Portrait mode (height > width). The ratio of the display screen's visible width to its visible height is called the 'Aspect Ratio'. The most commonly used aspect ratio is 4:3. The diagonal length of the display screen is termed as the length of the display.

For example, a display of 3.5" means that the diagonal length of the display is 3.5", as shown in [Figure 5](#).

**FIGURE 5: A 3.5" QVGA DISPLAY IN LANDSCAPE MODE**



# AN1368

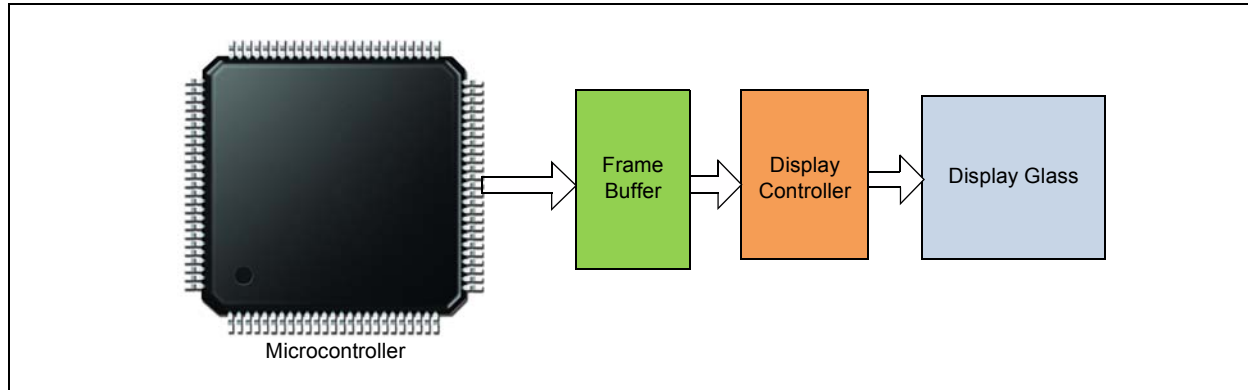
## GRAPHICS SUBSYSTEM HARDWARE

The hardware components required for a graphic application, with their interconnection and design decisions, are described in the following subsections.

## COMPONENTS OF A GRAPHICS SYSTEM

There are four basic components for any embedded graphics system, as illustrated in [Figure 6](#). They consist of the display glass, display controller, frame buffer and the microcontroller.

**FIGURE 6: THE FOUR BASIC COMPONENTS OF A GRAPHICS SYSTEM**



### Display Glass

Display glass is the device which displays a sequence of colors on the pixels and also converts the digital representation of colors to actual colors. The term, color, includes grayscale. Generally, the types of displays used are TFT LCDs, CSTN/MSTN LCDs or OLED/AMOLEDs.

All the LCD modules include gate and source drivers to drive the voltage and current for displaying all the pixels. [Table 1](#) gives a brief comparison of different display technologies.

**TABLE 1: COMPARISON OF DIFFERENT DISPLAY TECHNOLOGIES<sup>(1)</sup>**

Property	TFT LCD	STN (CSTN/MSTN)	AMOLED
Frame Rate	High	Low	High
Ghosting	No	Yes	No
HBLANK and VBLANK	Yes	No	Yes
Backlight	Required	Required	Not Required
Cost	Medium	Low	High
Typical Size for QVGA (320x240) Resolution	1.5" to 5.7"	1.5" to 5.7"	Up to 2.8"
Contrast	Medium	Low	High
Power Consumption	High	Medium	Low
Viewing Angle	Medium	Medium	High

**Note 1:** Data mentioned in this table may change due to constant changes or advancements in the display technology.

Some of the important properties of display technologies are explained as follows:

- **Frame Rate:** The number of times the display screen is refreshed in a second (this parameter does not reflect the refresh capacity of the microcontroller but only the capacity of the display glass).
- **Ghosting:** When the screen is changed, the previous frame is visible with lower intensity for a fraction of time, which appears to be the ghost of the current screen.
- **HBLANK and VBLANK:** Horizontal and vertical blanking periods, where the display is not updated. For more information, refer to **Section 43, “Graphics Controller Module (GFX)”** in the *“PIC24F Family Reference Manual”*.
- **Backlight:** For TFT/STN LCDs, backlight is necessary to view the display. It could be either CCFL or LED type.
- **Contrast:** It is defined as the ratio of intensities of white to black on the display. The higher the contrast, the better is the display quality.
- **Viewing Angle:** It is the horizontal or vertical angle within which the display is properly viewable.

The display glass has no inherent memory and must be constantly updated with pixel data in each row and column, failing which, the display will go blank (similar to DRAM refresh). This refreshing of the display data is handled by the display controller.

## Display Controller

The display glass must be constantly refreshed by feeding the horizontal and vertical pixel data repeatedly from the frame buffer. This task is performed by the display controller. It fetches the data from the frame buffer, decodes it to the required bit format and feeds it to the display glass, along with proper control signals. The display controller must adhere to the timing requirements of the display glass.

## Frame Buffer

The frame buffer is a memory (usually a RAM), which holds the data to be shown on the display screen and acts as the data source for the display controller. The required size of the frame buffer depends on the resolution and color depth. The minimum requirement is that it should hold the data required to display one full frame and must support the scan rate (preferred refresh rate as per the data sheet of the display glass) of the display controller.

### EQUATION 1:

$$\text{Frame Buffer Size Required (Bytes)} = \text{Number of Pixels} \times \text{Color Depth (Bits)/8}$$

### EXAMPLE 1:

For a QVGA (320x240) display using a 16 BPP color depth:

$$\begin{aligned} \text{Frame Buffer} &= 320 \times 240 \times 16/8 \\ &= 153,600 \text{ Bytes} \\ &= 150 \text{ Kbytes} \end{aligned}$$

### EXAMPLE 2:

For a WQVGA (480x272) display using a 16 BPP color depth:

$$\begin{aligned} \text{Frame Buffer} &= 480 \times 272 \times 16/8 \\ &= 261,120 \text{ Bytes} \\ &= 255 \text{ Kbytes} \end{aligned}$$

### EXAMPLE 3:

For a QCIF (176x144) display using an 8 BPP color depth:

$$\begin{aligned} \text{Frame Buffer} &= 176 \times 144 \times 8/8 \\ &= 25,344 \text{ Bytes} \\ &= 24.75 \text{ Kbytes} \end{aligned}$$

# AN1368

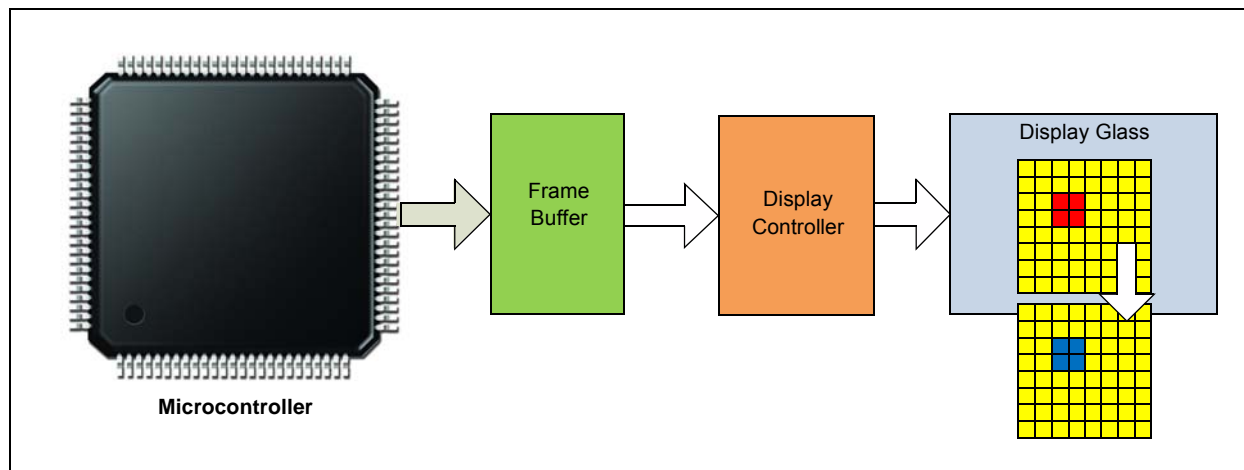
## Microcontroller

The application code running inside the microcontroller decides which data should be stored in the frame buffer, and as the frame buffer changes, the display content also changes. Each pixel's color is calculated and stored in the frame buffer. The microcontroller and the display controller must have the same settings, with respect to the color depth and memory range of the frame buffer being used. The microcontroller must have sufficient processing power (usually measured in MIPS) to render the required shapes in the frame buffer, such that it does not appear to be drawn slowly on the display screen. This is because the display

controller keeps pumping data from the frame buffer concurrently, with the microcontroller rendering pixels into the frame buffer. However, the microcontroller does not render any new shapes into the frame buffer if there is no change on the display screen. If there is a change on the screen, only the changed pixels need to be sent to the frame buffer, thereby minimizing the data transfer to the frame buffer.

In [Figure 7](#), only four pixels will be changed, and at a 16-bit color depth,  $4 * 16/8 = 8$  bytes need to be sent to the frame buffer.

**FIGURE 7: PIXEL DATA UPDATE**



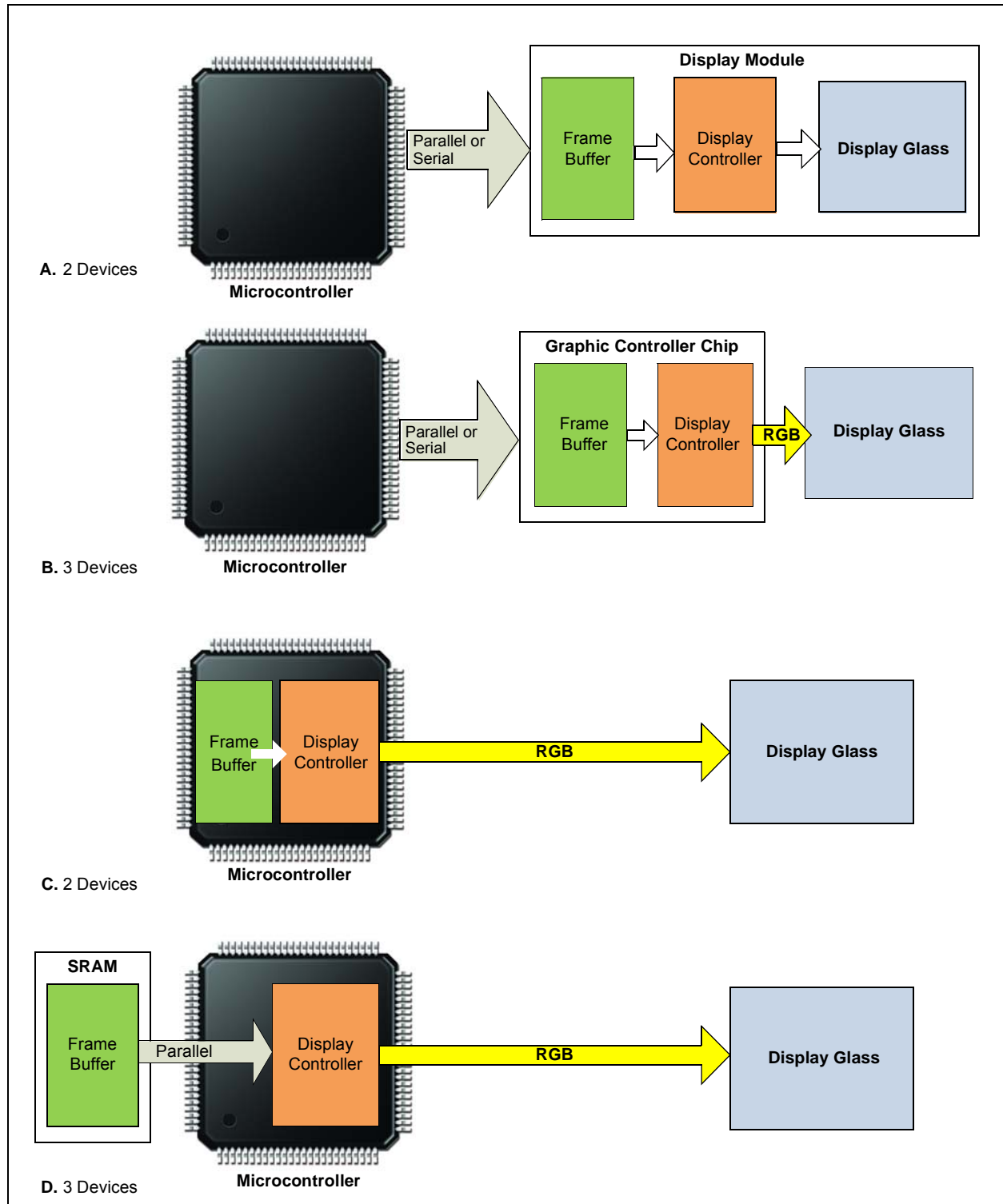
## INTEGRATION OF BASIC COMPONENTS

The choice of how to integrate the four basic components is an important step in designing a graphics application. To make the choice, the designer

needs to understand the types of combinations of these basic components that are possible in the form of ICs. There are four types of possible combinations, as illustrated in [Figure 8](#).

[Table 2](#) lists the advantages and disadvantages of the four combinations of the basic components.

**FIGURE 8: DIFFERENT WAYS OF INTEGRATING BASIC GRAPHICS' COMPONENTS**



# AN1368

**TABLE 2: BASIC COMPONENTS**

Options	Advantages	Disadvantages
<p><b>A.</b> The frame buffer and display controller are housed in a single module, called the 'Display Module'. The microcontroller and display module interface through a serial or parallel interface.<sup>(1)</sup></p>	<ul style="list-style-type: none"> <li>• No specific IC is required for graphics functionality</li> <li>• Less system components and less PCB space</li> </ul>	<ul style="list-style-type: none"> <li>• Generally higher cost</li> <li>• Usually forces a software driver change if the display module is changed</li> <li>• May lack additional memory required for double-buffering, animation, etc.</li> </ul>
<p><b>B.</b> The frame buffer is housed together with the display controller. The microcontroller and graphics controller communicate through a serial or parallel interface, whereas the graphics controller interfaces to the display glass through an RGB interface.<sup>(1)</sup></p>	<ul style="list-style-type: none"> <li>• Software driver change is not required if the display glass is changed. Only a compile-time configuration change may be needed.</li> <li>• Can be cheaper than Option A</li> </ul>	<ul style="list-style-type: none"> <li>• More system components and more PCB space</li> <li>• Display size is limited by the frame buffer inside the display controller</li> </ul>
<p><b>C.</b> The frame buffer and display controller are housed inside the microcontroller. The microcontroller interfaces to the display glass through an RGB interface. Instead of a display controller, a combination of a parallel interface and a DMA engine can be used as well.</p>	<ul style="list-style-type: none"> <li>• Only one IC is required for graphics functionality</li> <li>• Small form factor</li> <li>• Usually the cheapest option</li> <li>• Faster rendering since the memory is inside the microcontroller</li> <li>• Software driver change is not required if the display module is changed. Only a compile-time configuration change may be needed.</li> </ul>	<ul style="list-style-type: none"> <li>• Display size is limited by the frame buffer inside the microcontroller</li> </ul>
<p><b>D.</b> The display controller is housed inside the microcontroller. Separate RAM is used as the frame buffer. The microcontroller interfaces to the display glass (display panel) through an RGB interface and interfaces with the frame buffer through a parallel interface. Instead of a display controller, a combination of a parallel interface and a DMA engine can be used as well.</p>	<ul style="list-style-type: none"> <li>• The microcontroller can support the maximum display size possible as the size of the frame buffer can be selected by the user</li> <li>• Usually cheaper than Option A and B</li> </ul>	<ul style="list-style-type: none"> <li>• Requires an extra IC chip for the frame buffer</li> </ul>

**Note 1:** A serial connection can be used on low resolution displays with low color depth (e.g., 1 BPP, 120x64). With higher resolutions, the speed can be a bottleneck.

For Options A and B, the Microchip Graphics Library currently supports PIC24, dsPIC® and PIC32 microcontrollers with PMP or EPMP. The PIC24FJXXDAXXX family can support Options C and D. PIC24FJ256DA210 contains 96 Kbytes of internal memory and has a graphics controller inside. It also

supports optional external RAM as a frame buffer with a parallel interface through the EPMP module. For more information on the device, refer to the respective device data sheet and also **Section 43. "Graphics Controller Module (GFX)"** (DS39731) from the "PIC24F Family Reference Manual".

## POWER SEQUENCING IN DISPLAY PANELS

Different display panels will have different power supply requirements and timing to enable each of the power signals of the panel. In some display panels, the following power signals can be found:

- Digital Power Signal
- Analog Power Signal
- LCD Power Signal
- Backlight Power Signal

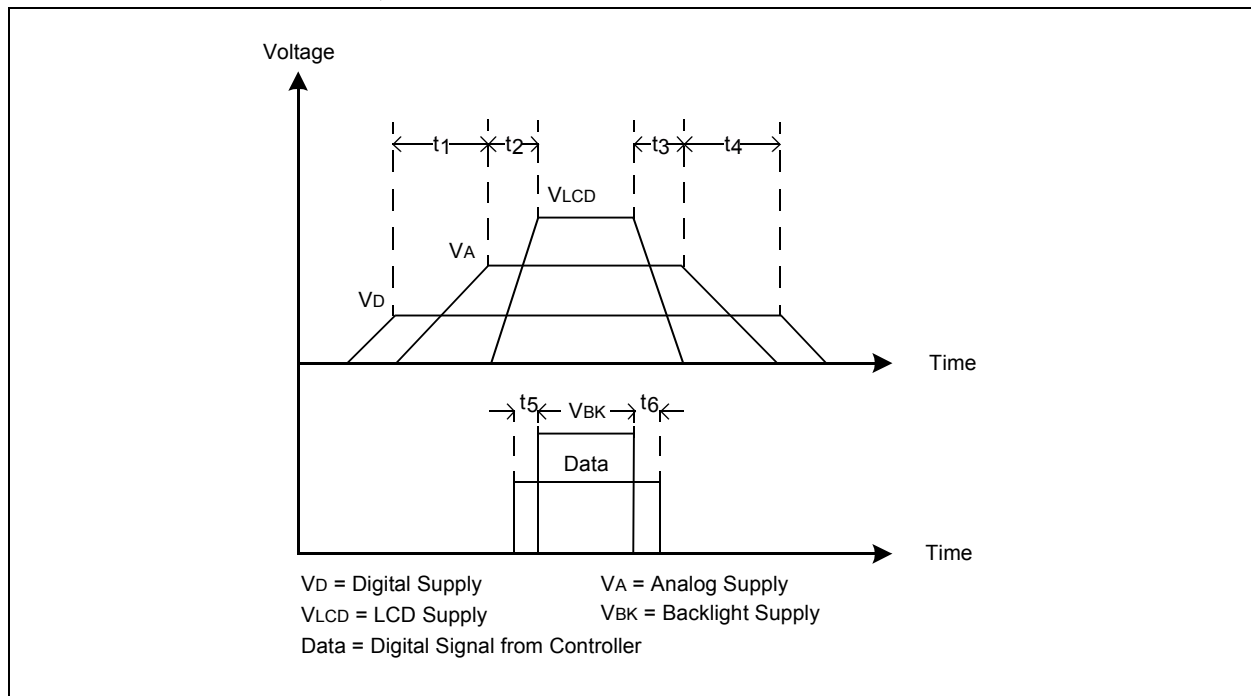
The digital power signal is used to power-up the digital logic on the panel. The analog power signal is used to power the analog portion of the panel. The LCD power signal, also known as the gate voltage, along with the digital data signals are primarily used to control the pixel illumination. In some cases, the LCD power signal is composed of two power signals: the positive LCD power signal and the negative LCD power signal. In some cases, only one signal is available. The backlight illumination is controlled by the backlight power signal.

Depending on the design of the display panel, all four types of the power signals can be found in the panel data sheet. In some cases, only the digital power and backlight signals appear. This means that the panel has integrated an internal circuitry to generate the analog and LCD power signals. This is usually true for small displays (2" to 4"). For larger displays, the analog and LCD power signals tend to be higher in voltage requirements. In these cases, it is not practical for the display panel to integrate such circuitry; therefore, those two power signals, that are specified as inputs, must be externally provided.

The different power signals of the display panel must follow the power sequencing recommended by the manufacturer. If the proper sequence is not followed, the display panel's life cycle can be reduced significantly. The typical power sequence of a panel is shown in [Figure 9](#).

Timing requirements are represented by  $t_1$ ,  $t_2$ ,  $t_3$ ,  $t_4$ ,  $t_5$  and  $t_6$ . In most cases, the requirements are represented as  $t_1 = t_4$ ,  $t_2 = t_3$  and  $t_5 = t_6$ .

**FIGURE 9: POWER SEQUENCE OF A PANEL**



## TOUCH SCREEN

Some applications require the support of a touch screen for the display. This is achieved by using a separate touch screen on the display glass or by selecting a display module with a touch screen. In both cases, the touch signals must be handled by either the microcontroller or a separate touch screen controller (such as Microchip's AR1000 series touch screen controllers). These touch signals are analog and digital signals which must be decoded to sense the touch coordinates. Transparent touch screens are usually of resistive type or capacitive type. Resistive touch screens are the most commonly used and are generally available in 4-wire or 5-wire configurations. The touch point can be detected by measuring the variation of the resistance of the touch screen. Only a 4-wire touch screen is explained here.

## 4-WIRE RESISTIVE TOUCH SCREEN

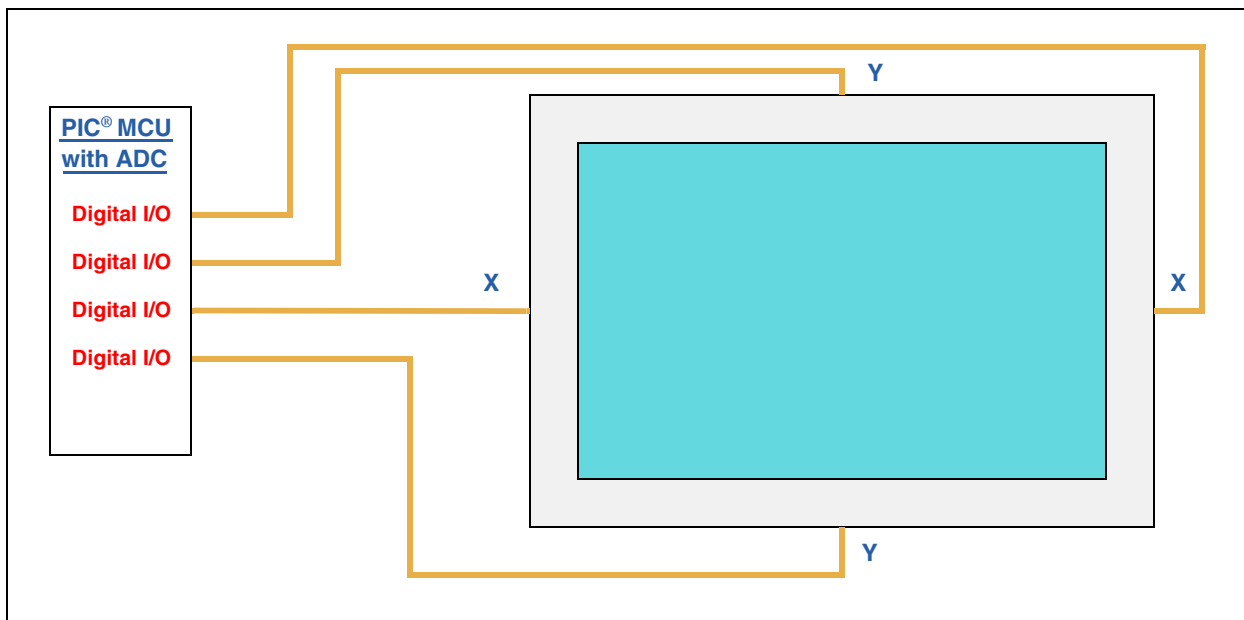
This touch screen has four signals, of which two are purely digital signals. The other two signals are alternately configured as both digital and analog signals.

The four signals can be directly connected to the microcontroller I/O pins with two digital inputs and two digital outputs, or analog pins. Figure 10 illustrates the connections for this scheme.

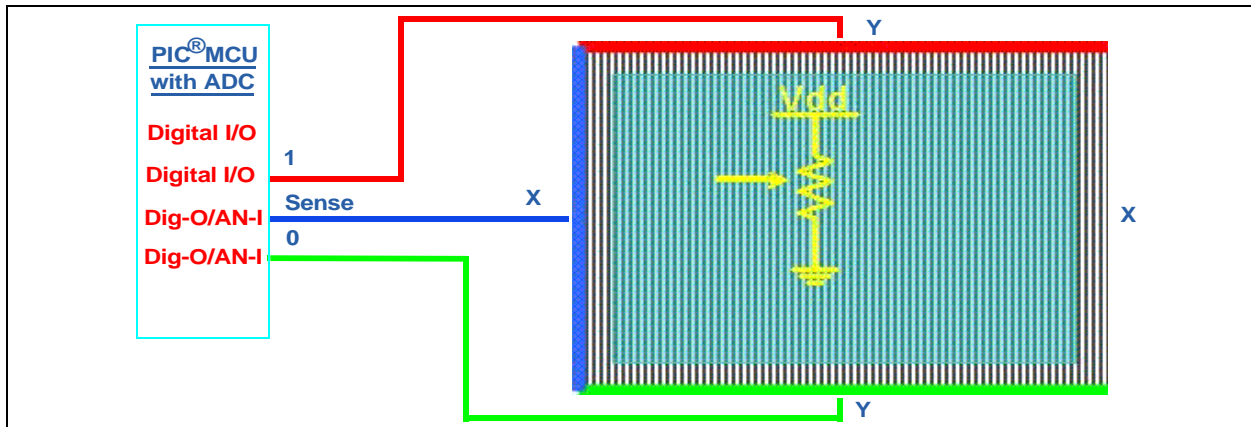
When the user touches the screen, the resistance of the screen changes. By measuring the resistance in horizontal and vertical directions, and comparing them with the calibrated values, the (x, y) coordinates of the point of touch can be obtained.

When a point on the screen is touched, the x-coordinate voltage is obtained by applying voltages across the y-signal and measuring the analog voltage on the x-signal, as shown in Figure 11. The y-coordinate voltage is obtained by applying voltage across x-signals and measuring the analog y-voltage, as shown in Figure 12.

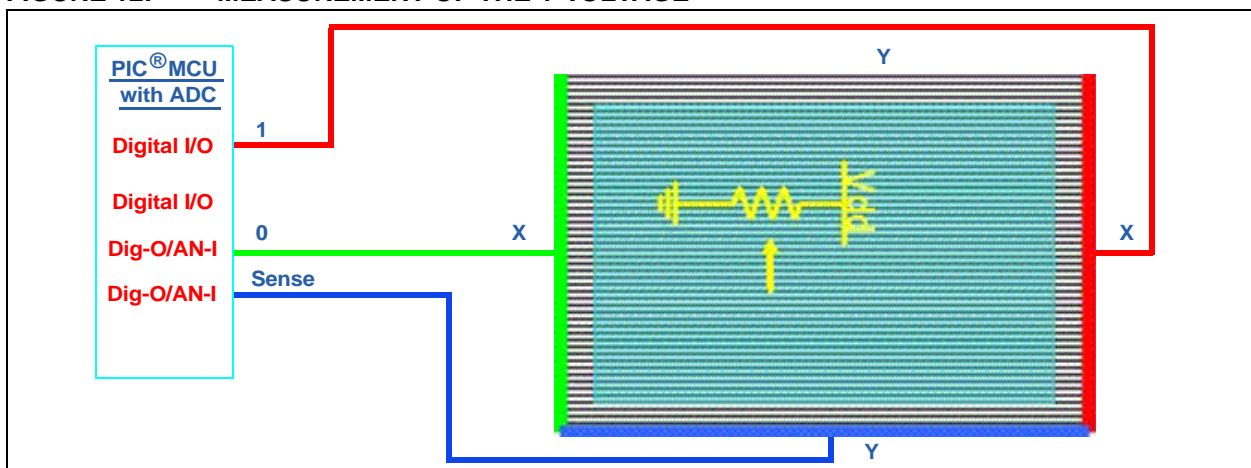
FIGURE 10: 4-WIRE RESISTIVE TOUCH SCREEN



**FIGURE 11: MEASUREMENT OF THE X-VOLTAGE**



**FIGURE 12: MEASUREMENT OF THE Y-VOLTAGE**



## DECISION FACTORS

After understanding the basic definitions and components of a graphics subsystem, the next step is to decide the specifications for the application. Some of the important factors that needs to be considered when deciding on specifications are as follows:

- Display Resolution and Size
- Display Orientation – Portrait or Landscape
- Color Depth (BPP)
- Frame Buffer Size
- Microcontroller Processing Power
- Configuration of Graphics Components
- Frame Rate vs. MIPS
- Interfacing with Unmatched Number of Display RGB Lines

These decision factors are described in the following sections.

## Display Resolution and Size

A particular resolution can be obtained in different display sizes. For example, QVGA (320x240) displays are available in a size range of 1.5" to 5.7". As the size increases, keeping the resolution constant, the pixels will look coarser, that is, curved shapes on the screen will appear blocky.

In an application, if the user needs to look at the display from a short distance (e.g., hand held devices), higher resolution displays are a better choice for larger displays. If the user looks at the display from a long distance (e.g., token number of displays at banks), larger sized displays with lower resolution may be used. If pictures are being displayed, it is better to use a higher resolution. Figure 13 illustrates how 'A' appears on a smaller sized lower resolution display, larger sized lower resolution display and larger sized higher resolution display, respectively.

**FIGURE 13: DISPLAY OF 'A' AT VARIOUS RESOLUTIONS**



## Display Orientation

Displays are available in Landscape (e.g., 320x240) or Portrait (e.g., 240x320) modes. A landscape display can also be used in Portrait mode by setting a 90° rotate function in the graphics library or display controller. Similarly, a portrait display can also be used in Landscape mode. If rotating the pixels is implemented by special hardware features inside the graphics controller, there is no penalty on the performance. However, if the rotation is performed in software (such as the graphics library used), there is a penalty in the software performance. This is because for every (x, y) point, a new rotated (x', y') point has to be calculated, which takes away some of the processing power.

Note the difference in the RGB strip alignment if the display is used in Rotated mode, as shown in Figure 14.

## Color Depth Selection

Along with the resolution of the display, the correct choice of color depth is another decision factor since this determines the size of the frame buffer (cost of RAM). If natural photos are being displayed, it is better to go with 16 BPP or higher. If 256 different colors are enough for the application, then a color depth of 8 BPP can be chosen (with the standard 256 colors provided by the display controller or custom 256 colors using CLUT (See [Appendix A: “Color Look-up Table \(CLUT\)”](#)). This would reduce the RAM requirement by 50%, compared to 16 BPP. If only 16 or 4 different colors are sufficient, 4 BPP or 2 BPP can be used, saving the RAM by 75% and 87.5%, respectively, as compared to 16 BPP. [Table 3](#) lists the RAM requirements for different color depths.

**FIGURE 14: LANDSCAPE AND PORTRAIT DISPLAYS USED IN LANDSCAPE MODE**



**TABLE 3: RAM SIZE REQUIREMENT FOR DIFFERENT COLOR DEPTHS**

BPP for QVGA (320x240)	16 BPP	8 BPP	4 BPP	2 BPP
Number of Colors	65,536	256	16	4
RAM Size (Bytes)	153,600	76,800	38,400	19,200

## Frame Buffer Size

The size of the frame buffer is calculated as follows:

### EQUATION 2:

$$\text{Frame Buffer (Bytes)} = \frac{\text{Total\_number\_of\_pixels} \times \text{Color\_Depth (in BPP)}}{8}$$

Table 3 shows an example for the QVGA (320x240) display. If the double-buffering technique is used, the frame buffer requirement will double (see [Appendix B: “Double-Buffering”](#) for more information).

If the frame buffer is inside the display controller or the smart display module, and if the RAM is fixed, the maximum resolution that can be supported is limited.

## Processing Power (MIPS)

The processing power required is application-specific. It depends on how many graphic elements are displayed on the screen and the complexity of the graphic elements. More processing power is required to draw complex shapes, such as a circle, bevel, text, etc., rather than lines and rectangles. The processing power requirements also depend on if a hardware graphics accelerator is available and used. Processing power requirements also depend on the update rate of the screen elements. For many embedded graphics applications,  $\geq 16$  MIPS processing power could be sufficient. The best way to check the processing power requirements is to evaluate using the standard graphics development tools. (For more information on development tools, see the [“Development Tools”](#) section.

## Configuration of Graphics Components

In [Table 2](#), each configuration has its own advantages and disadvantages.

Most often, the decision to use one or another configuration is not influenced by the technical advantages or disadvantages, but rather by a supply chain advantage or the availability of components. The designer must balance between optimizing a design to meet the requirement and managing the supply chain.

## Frame Rate vs. MIPS

Frame rate refers to the number of different frames that can be displayed in a second. This is a good performance index for display of a video, but not for an embedded GUI application. In general, an embedded application does not always change the entire screen, instead it changes a part of the screen, like a button or a check box. The amount of change depends on the size of the changed widget. The update time also depends on factors, such as if the change belongs to a widget or an image. It is important to consider the worst-case scenario on the planned application. Initial calculation of frame rate and MIPS is important to get the preliminary requirements for the system. In addition to these calculations, it is recommended to evaluate the system using development tools, such as evaluation kits.

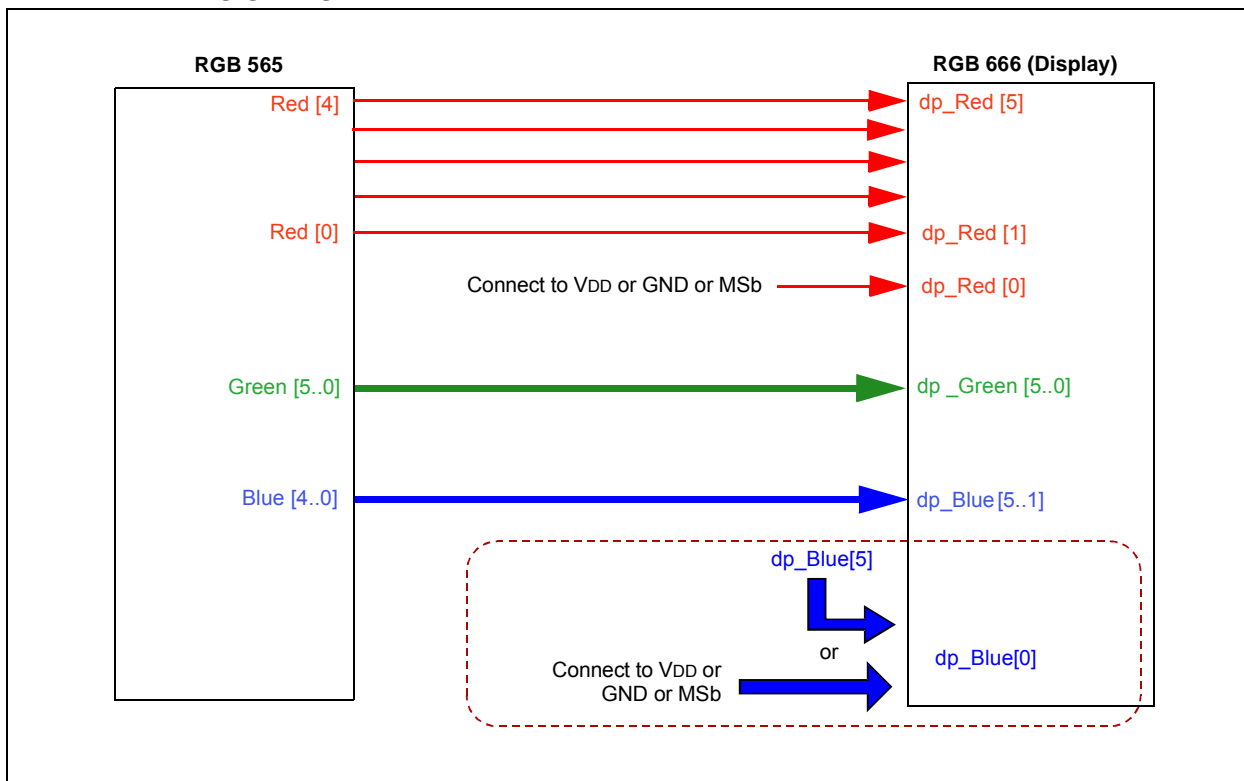
# AN1368

## Interfacing with an Unmatched Number of Display RGB Lines

It is possible that the display controller's number of RGB line outputs is different from the number of RGB line inputs of the display; it is still possible to interface both of them. If the display's RGB input lines are equal to the display controller's RGB line outputs, there will be no color degradation. If not, there may be a slight color degradation because the display panel will be unable to display all the colors generated by the display controller. Usually, the former case is encountered rather than the latter.

In [Figure 15](#), the display panel has more RGB signal lines than the display controller. Here, all the RGB lines of each color of the display controller are connected to the MSBs of the display's display signal lines. The unconnected LSBs may be connected to Ground or VDD, or to the MSb of the same color. Connecting the LSBs to the MSBs is the widely used method, since this enables the display to have a wider range of color values.

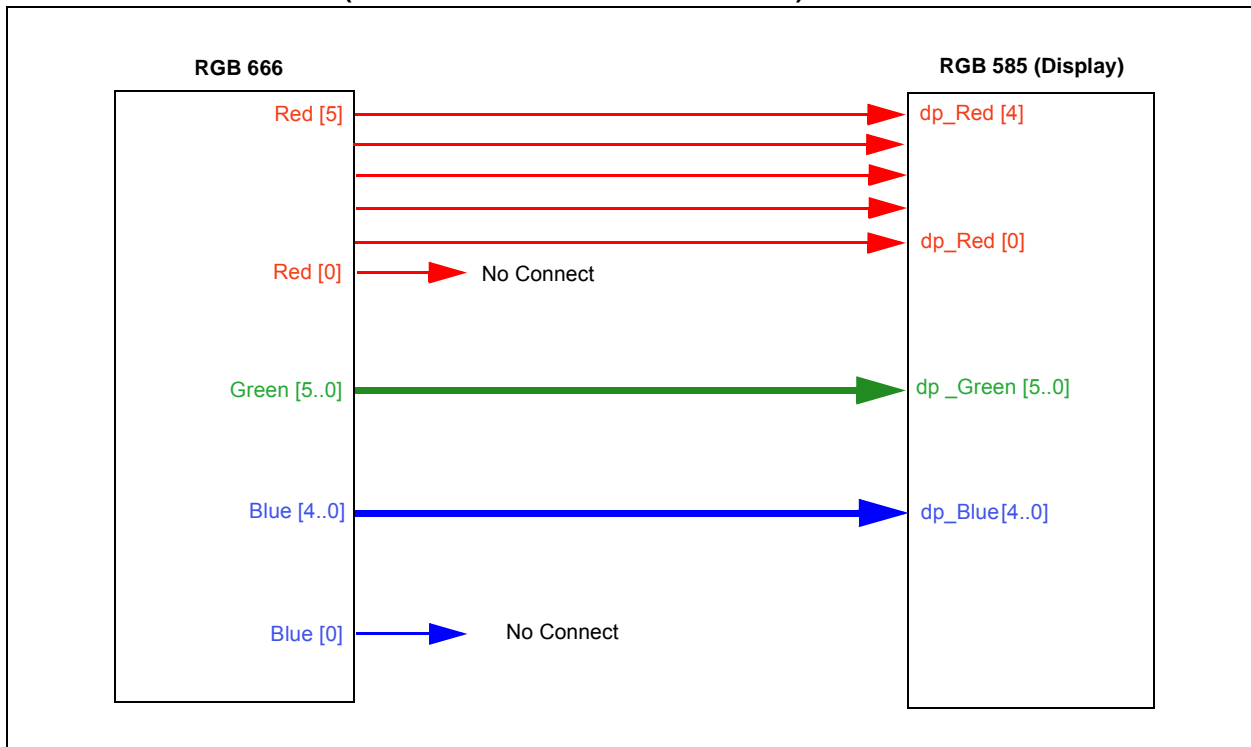
**FIGURE 15: DISPLAY CONTROLLER'S DISPLAY SIGNALS LESS THAN LCD'S DISPLAY SIGNALS**



In Figure 16, the display LCD has less display signal lines than the display controller.

The MSBs of the display lines of each color of the display controller are connected to all the display signal lines of the LCD. The unconnected LSBs may be left unconnected.

**FIGURE 16: DISPLAY CONTROLLER'S DISPLAY SIGNALS ARE MORE THAN LCD'S DISPLAY SIGNALS (POSSIBLE COLOR DEGRADATION)**



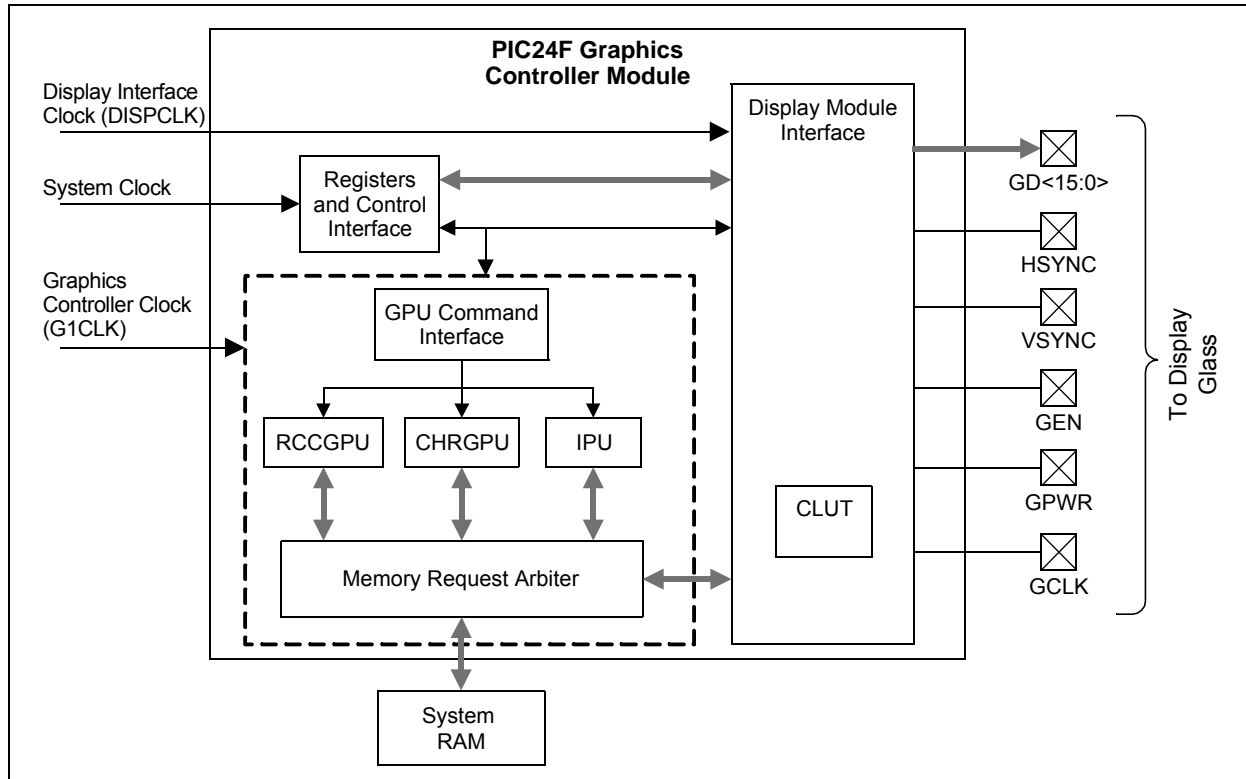
# AN1368

## THE PIC24FJ256DA210 MICROCONTROLLER

The PIC24FJ256DA210 device is a 16-bit microcontroller which supports a processing speed of up to 16 MIPS. The microcontroller includes 96 Kbytes of internal RAM and a built-in display controller with Graphics Processing Units (GPUs) to accelerate the drawing of common 2D shapes.

It can also interface with optional, external parallel RAM through the Enhanced PMP module to increase the size of the frame buffer. The PIC24FJ256DA210 graphics controller module is shown in [Figure 17](#).

**FIGURE 17: PIC24FJ256DA210 GRAPHICS CONTROLLER MODULE**



- DISPCLK is the clock which drives the display glass.
- System clock is the clock speed at which the program accesses the Command/Control/Status registers.
- G1CLK is the clock which drives the GPUs to draw lines, rectangles, render characters and decode compressed data without the involvement of the processor.
- External RAM, up to 16 MB, can be connected through the EPMP module using a parallel interface. The graphics module can use this on its own without any involvement of the processor. The interfaces allowed are limited to an 8-bit or 16-bit parallel connection. For more options and information, refer to **Section 42. “Enhanced Parallel Master Port (EPMP)”** (DS39730) in the *“PIC24F Family Reference Manual”*.
- HSYNC, VSYNC are the horizontal and vertical synchronization signals to the display.
- GCLK is the pixel clock.
- GEN is a signal that varies in function for TFT and STN display types of interfaces. For TFT, this signal indicates that data lines are valid. For STN, this signal toggles per line on the Line Toggle mode and toggles per frame for the Frame Toggle mode. For more information, refer to **Section 43. “Graphics Controller Module (GFX)”** (DS39731) in the *“PIC24F Family Reference Manual”*.
- GD<15:0> carry the display RGB or Gray values as per the graphics module settings. Only the required number of lines is enabled, depending on the interface requirements of the display. (e.g., 16 lined for TFT LCD’s RGB565 input or four lines for MSTN’s grayscale input).

- GPWR is the power supply control signal for the display glass. In some large displays, an external circuitry may be needed. Use this signal to enable or disable the external power circuitry. In displays that include an internal power circuitry, this signal can be connected to the display’s power enable pin. This signal should not be used as a power supply line to the display glass.

**Table 4** lists the number of microcontroller pins required for various display and RAM configurations.

The Graphics Processing Units (GPUs) like the Character Graphical Processing Unit (CHRGPU), Rectangle Copy Graphics Processing Unit (RCCGPU) and Inflate Processing Unit (IPU) are the graphics accelerators. These accelerators are used for rendering characters, rectangles and to decompress the compressed data, respectively.

These GPUs help to free the processing power of the microcontroller, which can be used for the purpose of the application. Instead of the CPU rendering the pixels, the application only needs to issue the commands to draw primitive rendering functions (such as lines, bars and characters) to the screen. After issuing the commands, the CPU is free to perform other application tasks. The application code runs in parallel to the RCCGPU, which concurrently draws the line. However, care should be taken because returning from a function, for example, `Line()`, need not imply that the line is completely drawn. This is called a non-blocking draw. The drawing can also be made blocking by setting the proper compiler switch in the `GraphicsConfig.h` file, as explained in future sections.

**TABLE 4: MICROCONTROLLER PINS**

Configuration	Display Data Pins (RGB)	EPMP Pins	Other (Clock and Sync) Pins	Total
A TFT LCD without External RAM (using CLUT and 16-bit colors)	16	0	5	21
A 256-Color CSTN without External RAM	8	0	5	13
A TFT LCD with External 16-Bit Wide RAM of 256 Kbytes (using 16-bit colors)	16	37	5	58
A 16-Color MSTN without External RAM	4	0	5	9

The GPUs are briefly explained below:

- **CHRGPU:** Renders the characters on the display. A font table must be loaded into the RAM and the CHRGPU must point to that font table. The (x, y) coordinates must also be initialized on the appropriate CHRGPU registers. When a character code and the draw command are given, the character will be rendered on the configured RAM area, which can also be the frame buffer. The user must take care of the display glass orientation as the characters cannot be rotated dynamically by the CHRGPU. The CHRGPU does not support anti-aliased fonts; all the pixels on a character are of the same color. The background and foreground colors are set using the CHRGPU commands. If transparency is enabled, only the foreground color is drawn, and if the transparency is disabled, the background color is also drawn surrounding the character. To use the CHRGPU by default, uncomment the line: `#define USE_DRV_OUTCHAR` in `MicrochipGraphicsModule.h`.
- **RCCGPU:** Used to draw horizontal or vertical lines, rectangles, filled rectangles, and to copy rectangular regions. RCCGPU can perform the following three operations:
  - Copy – Copy a memory block from one part of the RAM to another. Depending on the command parameter, the block of memory can be a contiguous block or a rectangular block.
  - Copy with Solid Fill – Fill a rectangular area with a specific color.
  - Copy with Transparency – Same as the copy option, but a color set apart to indicate transparency will not be copied to the destination, leaving that part of the destination unchanged.

Each operation can use one of the 16 available logical operations, called Raster Operations (ROPs), which is applied while copying.

For example, source can be copied as is or the source can be ORed with the destination area, or the source can be ANDed with a separate region and copied to the destination area. For more information on the Graphics Controller Module (GFX) and the supported ROPs, refer to the **Section 43. “Graphics Controller Module (GFX)”** (DS39731) in the *“PIC24F Family Reference Manual”*.

The RCCGPU can be used to achieve special effects, such as screen animations, like scrolling, peeling, etc. For more information on the advanced usage of the RCCGPU, see **Appendix C: “Advanced Usage of RCCGPU”**.

- **IPU:** Used to decompress a compressed data using the DEFLATE algorithm with Fixed Huffman codes. For example, images can be compressed and kept in the internal Flash or external memory and they can be decompressed into RAM during run time. Similarly, compressed user-specific data can also be decompressed and used during run time with the IPU. It should be noted that decompression can only commence from the beginning of a compressed block and not from the middle. For example, when storing multiple images, compress each image to its own compressed block. The IPU can be used to decompress any images by specifying the location of the desired compressed block. The Microchip Graphics Library will handle this scenario, making it transparent to the users.

**Note:** Bit maps can be compressed by selecting the “IPU” option in the Graphics Resource Converter (GRC) tool while converting the images. GRC is a tool included in the installation of the Graphics Library. The `PutImage()` API automatically decompresses these compressed images using the IPU at run time. The user is required to allocate the required amount of RAM for IPU operation, using compile-time options as described in the Microchip Graphics Library Help file.

For more information on these GPUs and their registers, refer to **Section 43. “Graphics Controller Module (GFX)”** (DS39731) in the *“PIC24F Family Reference Manual”*.

## DEVELOPMENT TOOLS

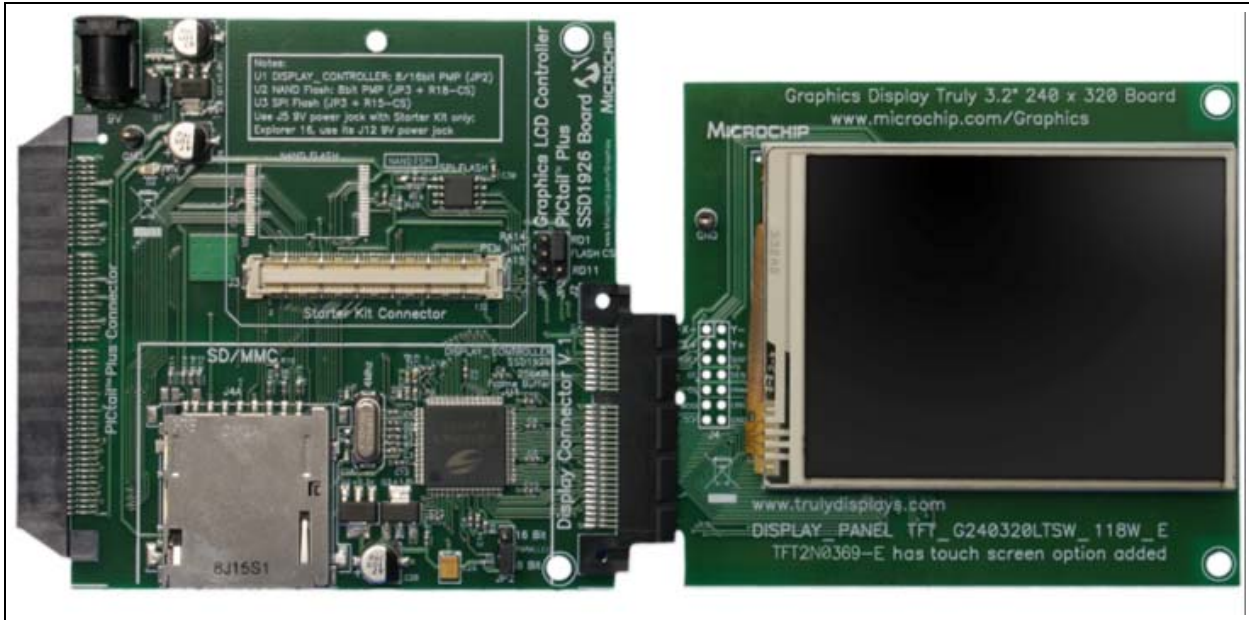
A fast and cost-effective way of evaluating the system specification of an application is through the use of existing development tools. Microchip has several development tools supporting graphics design. Two important tools that can be used for graphics development are:

- Graphics LCD Controller PICtail™ Plus SSD1926 Board (AC164127-5), which is an add-on board to the Microchip's generic development board for 16-bit and 32-bit microcontrollers, such as the Explorer 16 board and PIC32 starter kits.

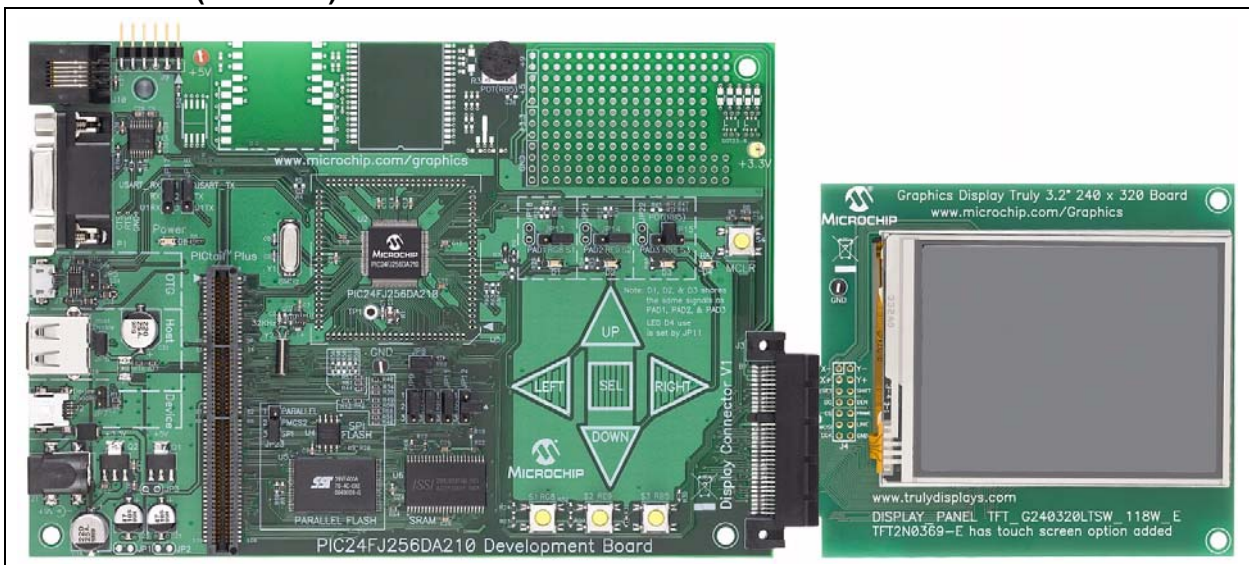
- PIC24FJ256DA210 Development Board (DM240312), which is a stand-alone board.

Both the boards require add-on display modules which are available with displays of various sizes. User-specific display panels can be used with the help of a display prototype board. [Figure 18](#), [Figure 19](#), [Figure 20](#) and [Figure 21](#) illustrate these development tools. For the latest tool set, visit: <http://www.microchip.com/graphics>.

**FIGURE 18: GRAPHICS PICtail™ PLUS DAUGHTER BOARD WITH 3.2" DISPLAY KIT (AC164127-3)**

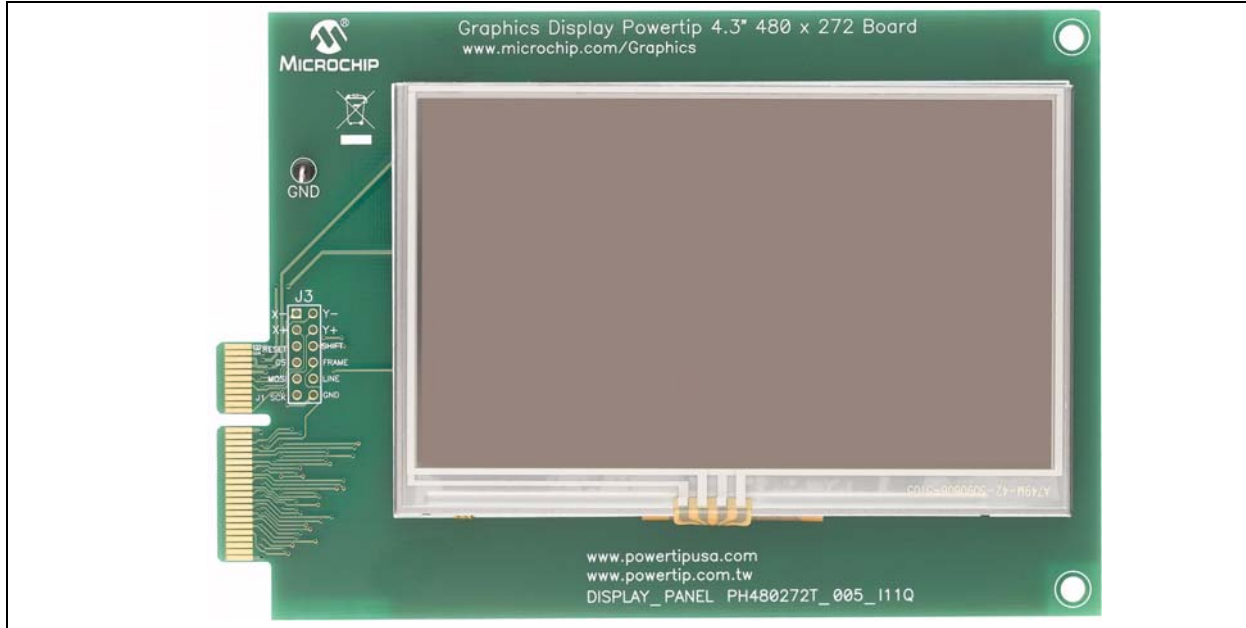


**FIGURE 19: DEVELOPMENT BOARD SUPPLIED WITH PIC24FJ256DA210 DEVELOPMENT KIT (DV164039)**

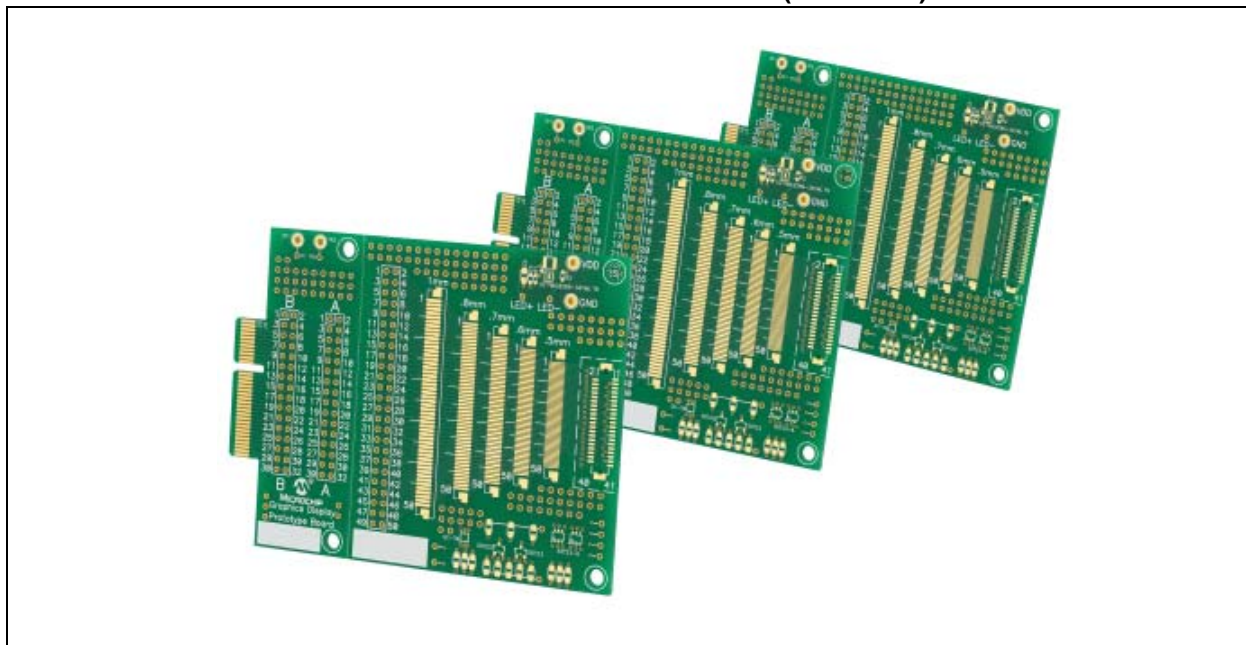


# AN1368

**FIGURE 20: 4.3" WQVGA POWERTIP TFT DISPLAY BOARD (AC164127-6)**



**FIGURE 21: GRAPHICS DISPLAY PROTOTYPE BOARDS (AC164139)**



## SOFTWARE

The basic software component required for any graphics application is a Software Display Driver which provides one basic operation (i.e., setting the color of a pixel). A driver may also implement APIs to draw fundamental shapes, for instance, a line, rectangle, bar, circle, text, image and so on. The Software Display Driver must be written for every separate graphics driver used. More complex graphic elements, like labels, buttons, check boxes, sliders and progress bars are implemented in higher layers, which in turn, use the Software Display Driver.

Microchip provides a 'free to use on PIC MCU' software library, called "Microchip Graphics Library", which contains the above discussed drivers and higher layers. Several demos are distributed with the graphics library which the user can run out of the box on the appropriate development tools.

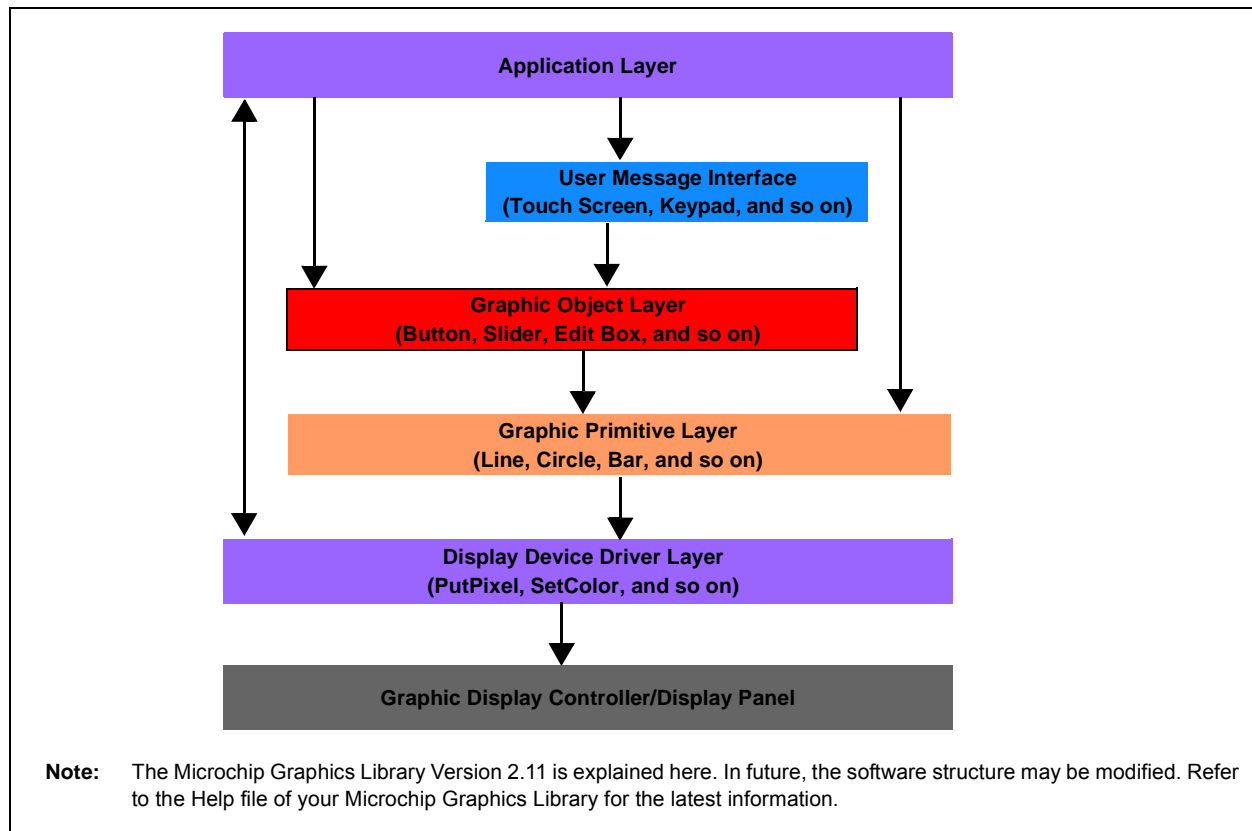
Features of the Microchip Graphics Library are:

- Works with 16-bit and 32-bit PIC<sup>®</sup> MCUs, as well as dsPIC<sup>®</sup> DSCs
- Modular design, compile only what is required
- Supports multiple user interfaces
- Not dependent on display size or resolution
- Low-cost, full-featured development tools
- Utilities to import fonts and images
- Free to Microchip customers
- Includes multiple low-level drivers

The structure of the Microchip Graphics Library is shown in Figure 22.

The Microchip Graphics Library v2.11 is distributed along with the Microchip Applications Library and is available for download at [www.microchip.com/MAL](http://www.microchip.com/MAL).

**FIGURE 22: STRUCTURE OF MICROCHIP GRAPHICS LIBRARY**



The Graphics Display Controller is the hardware module consisting of the frame buffer and Display Controller. The remaining layers are the software layers. The Microchip Graphics Library is organized in a set of folders under the folder, 'Microchip Solutions'. The 'C' files are in the folder, *Microchip Solutions/Microchip/Graphics*, and the header files are in the folder, *Microchip Solutions/Microchip/Include/Graphics*. The

development board-specific files are in the folder, *Microchip Solutions/Board Support Package*. The project path must be set to point to these folders.

Starting from the bottom-most Software layer to the top-most layer, the functionality of each layer and the files responsible for those layers are explained further in the following sections. For more information, refer to the Help file of the Microchip Graphics Library.

## DISPLAY DEVICE DRIVER LAYER

Every hardware display controller has its own set of commands and status information. Therefore, separate software drivers are needed for each supported display controller, which fulfills the requirements of the display driver and the standard APIs defined by the Graphics Library. The list of supported drivers can be found in the Graphics Library Help file. To know if a display module is supported, check if the display driver inside the display module is available in the above mentioned folder.

The main function provided by this layer is the initialization of the driver using the API `ResetDevice()`, painting a pixel using APIs, `SetColor(color)` and `PutPixel(x, y)`, and knowing the color of a pixel using the API `GetPixel(x, y)`. The other functionalities provided are, for example, setting up of clipping area, getting the maximum x and y values for a display screen, etc. An application can be written using only this layer without using any higher layers. In that case, all the shapes must be drawn by the user. To include this layer, the following files must be added to the project:

### HEADER FILES

`Graphics.h`  
`DisplayDriver.h` or `specific <Driver.h>`  
(like `SSD1926.h`)

### CONFIGURATION FILES

`HardwareProfile.h`  
`GraphicsConfig.h`

These files are project-specific and must be inside the project folder.

### SOURCE FILES

`Specific <Driver.c>` (like `SSD1926.c`)

## GRAPHIC PRIMITIVE LAYER

This is a layer above the Display Driver layer and provides most common services through APIs, which are used to draw basic shapes, for instance, line (normal, thick, dashed), bar, rectangle, circle, polygon, bevel and arc. It also provides APIs for drawing text and images. These are generic APIs which work with any given display driver. However, some of these APIs may be implemented by the Driver layer for optimized performance, especially if the driver supports 2D-Accelerations (For example, the Microchip Graphics module and SSD1926). It is possible to write simple applications by using Primitive and Driver layers only and without using higher layers. To include this layer, the following files must be added to the project:

### HEADER FILES

`Primitive.h`

### SOURCE FILES

`Primitive.c`

## GRAPHIC OBJECT LAYER (GOL)

The GOL consists of many selectable objects, called 'widgets', such as Button, TextBox, Check Box, ScrollBar, ProgressBar, Picture, ListBox, GroupBox, Meter, DigitalMeter, Dial, Chart and Grid, which form the basic elements of a complex graphics application. Each of these widgets is implemented in 'C', but with basic object-oriented principles, and can be used as modules. Use of this layer must be enabled at compile time in the 'GraphicsConfig.h' file. The use of individual widgets can be enabled or disabled during compile time in the 'GraphicsConfig.h' file, thereby saving RAM and ROM. For more information, see the "[Configuration](#)" section.

Each kind of widget has a default style scheme which defines the font and the colors used for various parts and states of the widget. For example, a button in a pressed state has a different color than the released button. The style scheme for each widget is explained in detail in the Help file of the Microchip Graphics Library. For each style scheme, some heap memory (dynamically allocated memory) is required to store the style scheme values. Heap is required to store the state information for each enabled widget. The total heap must be greater than the sum of heaps for all the instances of used widgets. Aside from the heap requirement, each widget type also needs to use RAM space for variables when rendering and managing the widgets. This additional RAM requirement is a constant overhead for each type of widget. The difference between the two is that the heap requirement is needed for each instance of a widget, while the RAM requirement is needed for each type of widget. The RAM requirement is constant and not dependent on the number of instances of one type of widget.

For example, if the Release note says:

Module	Button	GOL
Heap for PIC24F	28 (per instance)	20 (per style scheme)
Heap for PIC32	44 (per instance)	24 (per style scheme)
RAM for PIC24F	8	32
RAM for PIC32	12	28
ROM for PIC24F	1002	2076
ROM for PIC32	2748	5400

**Note:** The RAM and ROM requirements for PIC24F and PIC32 devices may be different because of different microcontroller architecture and different compilers.

For a PIC24F application using only two buttons, a RAM of 8 bytes, ROM of 1002 bytes and the required heap memory would be  $2 \times 28 = 56$  Bytes.

If one style scheme is used, then a heap memory of 20 bytes would be required.

### EQUATION 3:

Total Heap (Minimum Required Heap) = 20  
(for the Style Scheme) +  $(2 \times 28) = 76$  bytes  
Total RAM (for Graphics) = 32 (for GOL) + 8 = 40 bytes

**Note:** This example is indicative only. It is recommended to see the release notes of the Microchip Graphics Library to derive the appropriate values for that particular release.

The GOL depends on the Primitive and the Display Driver layers. A function, `GOLDraw()`, must be called continuously in a loop to simplify the drawing of widgets. Additionally, a function, `GOLDrawCallback()`, must be implemented in the application code. This is used for custom drawing which is explained in the Help file. Generally, this function can just return: TRUE.

To include the GOL, along with the files required for the Primitive layer and Display Driver layer, the following files must be added to the project. See the Help file for the latest list of files. If the GOL is used, then in the `GraphicsConfig.h` file, the macro, `#define USE_GOL`, must be defined. Individual macros for the widgets used, such as `#define USE_BUTTON`, must also be defined. If these individual macros are not defined, the widgets will not be compiled even if they are included in the project.

Users can also create their own widgets and add to the graphics library. See "[References](#)" for more details.

File Category	Button
Header Files	<ul style="list-style-type: none"> <li>• GOL.h</li> <li>• Button.h</li> <li>• Chart.h</li> <li>• CheckBox.h</li> <li>• DigitalMeter.h</li> <li>• EditText.h</li> <li>• Grid.h</li> <li>• GroupBox.h</li> <li>• ListBox.h</li> <li>• Meter.h</li> <li>• Picture.h</li> <li>• ProgressBar.h</li> <li>• RadioButton.h</li> <li>• RoundDial.h</li> <li>• Slider.h</li> <li>• StaticText.h</li> <li>• TextEntry.h</li> <li>• Window.h</li> <li>• &lt;CustomWidget.h&gt;</li> </ul>
Configuration Files	<ul style="list-style-type: none"> <li>• GraphicsConfig.h (to select the usage of GOL and its individual widgets)</li> </ul>
Source files	<ul style="list-style-type: none"> <li>• GOL.c</li> <li>• GOLFontDefault.c</li> <li>• Button.c</li> <li>• Chart.c</li> <li>• CheckBox.c</li> <li>• DigitalMeter.c</li> <li>• EditText.c</li> <li>• Grid.c</li> <li>• GroupBox.c</li> <li>• ListBox.c</li> <li>• Meter.c</li> <li>• Picture.c</li> <li>• ProgressBar.c</li> <li>• RadioButton.c</li> <li>• RoundDial.c</li> <li>• Slider.c</li> <li>• StaticText.c</li> <li>• TextEntry.c</li> <li>• Window.c</li> <li>• &lt;CustomWidget.c&gt;</li> </ul>

**Note:** This list is for indication only. Refer to the Microchip Graphics Library Help file for the latest list of files.

## USER MESSAGE INTERFACE

The user message interface is a sublayer of the GOL which is enabled if the GOL is used. This sublayer is used to facilitate the message passing between widgets and user input. For example, if the user presses a button, then a message is sent to a call back function, called `GOLMsgCallback()`, where the message indicating that the button is pressed is checked and an action is taken. This callback function must be present in the application code if the GOL is being used, no matter if message passing is being used or not. If the message passing is not used, the function body must return a '1'.

Similar to `GOLDraw()`, `GOLMsg()` must be called continuously in a loop inside the application code to facilitate message collection and passing.

The usage of `GOLDraw()`, `GOLDrawCallback()`, `GOLMsg()` and `GOLMsgCallback()` are explained in [Example 4](#), [Example 5](#) and [Example 6](#).

## APPLICATION LAYER

In this layer, the user has full control of the application. Initially, the user must initialize the Microchip Graphics Library. The initialization is done by calling `GOLInit()` if all the layers are being used, `InitGraph()` if the GOL is not being used but the Primitive and Display Driver layers are being used, or by calling `ResetDevice()` if only the Display Driver layer is being used. After the initialization routine, the Primitive and Driver layers' APIs can be called to achieve the required draw functionality. To use GOL objects (like buttons), the widgets must be created by calling the widget's create function (e.g., `BtnCreate()`), one by one, until all of the widgets are created. This step will not display the widgets. The created widgets are drawn on the screen when the `GOLDraw()` function is called repeatedly in a while loop. The messages are processed by calling the `GOLMsg()` inside the same loop, as shown in [Example 5](#).

After `GOLDraw()` is done, messages are received from the touch screen driver and hard buttons driver. The obtained message is passed to `GOLMsg()` to process and to output a widget-specific message. For example, it converts a "USER TOUCHED POSITION 100, 100" message to `BUTTON1_PRESSED`.

Additionally, the application must possess the `GOLDrawCallback()` and `GOLMsgCallback()` functions.

If custom drawing is not done, then the draw callback is used, as shown in [Example 4](#).

### EXAMPLE 4:

```
WORD GOLDrawCallback(void)
{
    return (1);
}
```

The message callback handles the processed message sent out by the widgets, as shown in [Example 6](#).

If the application already uses a main loop, `GOLDraw()` and `GOLMsg()` can be called within the loop (see [Example 5](#)).

- Note 1:** Refer to the application note, *AN1136, "How to Use Widgets in Microchip Graphics Library"* for creating a simple application.
- 2:** Refer to the Microchip Graphics Library Help file for the list of related application notes.

## EXAMPLE 5:

```
while(1)
{
    if(GOLDraw())
    {
        // Draw GOL objects
        // Drawing is done here, process messages
        TouchGetMsg(&msg); // Get message from touch screen
        GOLMsg(&msg); // Process message
        SideButtonsMsg(&msg); // Get message from side buttons
        GOLMsg(&msg); // Process message
    }
}
```

## EXAMPLE 6:

```
WORD GOLMsgCallback(WORD objMsg, OBJ_HEADER *pObj, GOL_MSG *pMsg)
{
    // beep if button is pressed
    if(objMsg == BTN_MSG_PRESSED)
    {
        Beep();
    }
}
```

## CONFIGURATION

The configuration of the Microchip Graphics Library is done through two files:

- GraphicsConfig.h
- HardwareProfile.h

### GraphicsConfig.h

The software library related configurations are done in GraphicsConfig.h. The available options are:

1. **USE\_NONBLOCKING\_CONFIG:** If this option is defined, then the Non-Blocking mode of the API calls is used; that is, the APIs with return status values can return without completing their task. The task may complete some time after returning. This is especially useful if 2D-Acceleration is supported by the display driver. In that case, the application can regain control while rendering is being processed in parallel. This reduces Idle time for the microcontroller waiting for the rendering of a primitive command (such as `line()`, `bar()`). If this define is disabled (commented out), then all API calls return only after the completion of their task. For non-blocking configuration, the user must check the return value of the API to know if its execution got completed or not.
2. **USE\_DOUBLE\_BUFFERING:** If this option is defined, two buffers will be used. One buffer will be used as a draw buffer, where the next screen is rendered, and the other as a frame buffer, which holds the visible pixels of the screen. This mode is used to avoid visible slow drawing on the screen, like rendering of a large area or decoding and displaying of an image. This mode uses twice the amount of the frame buffer and the library currently supports this feature only for certain graphics controllers (refer to the documentation of the Microchip Graphics Library). If this option is commented out, then only one buffer is used as the frame buffer and the changes to the screen are visible at the same time.
3. **USE\_PALETTE:** If this option is defined, Palette mode is enabled and the colors are taken from the palette table. This option is available only to controllers that have a built-in, programmable, color look-up table (example: PIC24FJ256DA210 has a graphics module with a color look-up table). The table is required to initialize the palette engine and set a valid palette table before displaying anything on the screen. The library supports this feature only for PIC microcontrollers with a built-in display controller. The `COLOR_DEPTH` setting can be 1, 2, 4 or 8 with the palettes enabled. If disabled, Normal Color mode will be used.
4. **USE\_FOCUS:** If this option is defined, a dashed outline (focus line) is displayed on the selected widget. This focus line is especially useful for navigation and selection of widgets if push buttons are used as user input.
5. **USE\_TOUCHSCREEN:** This option enables the touch screen support for the application by enabling the touch message processing part of the GOL.
6. **USE\_KEYBOARD:** This option enables the physical keys support for the application by enabling the hard key message processing part of the GOL.
7. **USE\_GOL:** This option enables the Graphic Object Layer (GOL). Initially, `GOLInit()` must be called. `GOLDraw()` and `GOLMsg()` must be called repeatedly in a loop and `GOLDrawCallback()` and `GOLMsgCallback()` functions must be implemented by the application.
8. **USE\_BUTTON, USE\_CHECKBOX, USE\_WINDOW, ... , USE\_CUSTOM:** These options are valid only if `USE_GOL` is defined. They enable the support of each widget in the application and each enabled widget will use its share of RAM, ROM and heap.
9. **USE\_MULTIBYTECHAR:** This will make the `XCHAR`, 2 bytes long so that Unicode (UTF16) is supported. Languages other than English characters can be supported by the usage of Unicode. Enable this option if multiple language support is needed in the application and disable (comment out) this option if only ASCII is used. If this option is disabled, `XCHAR` takes one byte per character.
10. **USE\_FONT\_FLASH:** Supports fonts stored in the internal Flash of the microcontroller to be used in the application.
11. **USE\_FONT\_RAM:** Supports fonts stored in the RAM of the microcontroller to be used in the application. This is used as font accelerations in PIC microcontrollers with a built-in display controller.
12. **USE\_FONT\_EXTERNAL:** Supports fonts stored in the external memory (serial or parallel Flash) to be used in the application. The application needs to implement a function, `WORD ExternalMemoryCallback(EXTDATA *memory, LONG offset, WORD nCount, void *buffer)`, to get data from the external memory.
13. **COLOR\_DEPTH:** Specifies the color depth used in the demo in bits-per-pixel and it can take values, such as 1, 2, 4, 8, 16 or 24 (limited by the hardware capabilities).

14. **USE\_BITMAP\_FLASH:** Supports bit map images stored in the internal Flash of the microcontroller to be used in the application.
15. **USE\_BITMAP\_EXTERNAL:** Supports bit map images stored in the external memory (serial or parallel Flash) to be used in the application. The application needs to implement a function, `WORD ExternalMemoryCallback (EXTDATA *memory, LONG offset, WORD nCount, void *buffer)`, to get data from the external memory.

**Note:** Refer to the Microchip Graphics Library Help file for the latest set of configuration options.

### HardwareProfile.h

This file is used to configure hardware for an application and is similar to the usage as in other Microchip software libraries. If a `HardwareProfile.h` already exists in the application, the following definitions can be added to it, and if not, a new file with the following definitions must be created. This file mainly contains the following sections:

1. **GetSystemClock():** This macro must return the frequency of the system clock in Hertz.
2. **GetPeripheralClock():** This macro must return the frequency of the peripheral clock in Hertz. In PIC24 microcontrollers, this is half of the system clock. For more information on PIC32 devices, refer to the respective device data sheet.
3. **GetInstructionClock():** This macro must return the frequency of the instruction clock in Hertz. In PIC24 microcontrollers, this is half of the system clock, and in PIC32 microcontrollers, this is the same as the system clock.
4. **Display Related Settings:** These settings contain a set of `#defines` which defines the various display related parameters, such as the type of the display (TFT or CSTN or MSTN), resolution of the screen, color depth, display clock speed, various display timing parameters, address of the draw buffer and frame buffer among others.
5. **I/O Ports for Keys:** Provide definitions of the I/O pins used in the application. These can be used as inputs for switches or outputs to turn on LEDs, or application controlled pins to enable specific hardware.
6. **External Memory Definitions:** These `#defines` provide the definitions of port pins and/or module initialization, such as for SPI, I<sup>2</sup>C™ or PMP to interface to the microcontroller with the external memory (EEPROM, Flash or SD Card).

7. **Touch Screen Definitions:** These `#defines` provide the definitions and setup information of ADC channels used for sensing a touch in touch screen-enabled applications.
8. **RTCC Definitions:** These `#defines` provide setup information for the RTCC module if an internal Real-Time Clock (RTC) is used in the application.
9. **Communication Definitions:** These `#defines` provide the definitions and setup information of communication modules, such as UART/USB channels used for communication proposes in the application.
10. **Application-Specific Definitions:** Any other application-specific hardware definitions can be included here.

Refer to any graphics demo distributed with the Microchip Graphics Library for specific details or for use as an example.

**Note:** Refer to the Microchip Graphics Library Help file for the latest set of configuration definitions.

### OTHER GRAPHICS LIBRARIES FOR PIC MICROCONTROLLER

Apart from Microchip, there are various third parties that provide a graphics library for PIC MCUs. For example:

- Segger's emWin Graphics Library
- Micrium's  $\mu$ C/GUI

### CONCLUSION

Support for embedded graphics is becoming important in recent user interface applications. Microchip supports their customers in multiple ways by providing development tools, graphic libraries, graphic-enabled microcontrollers (PIC24FJ256DA210) with extensive documentation, demo codes and support. Microchip's graphics solutions can be successfully used for many embedded graphics applications resulting in less time to market and lower cost.

## APPENDIX A: COLOR LOOK-UP TABLE (CLUT)

### A Recap of Basic Concepts

Before understanding the concept of a CLUT, image representations and their data types should be understood.

A digital image consists of pixels, also known as Pels. This is a binary image ('0' or '1') and is represented by a simple on/off of a pixel. It is also called a monochrome image, and for a 640x480 screen size, the image size is  $(640 \times 480 / 8)$  37.5 Kbytes.

Image resolution refers to the number of pixels in an image. Aspect ratio is the ratio of the column/row. In the above example of 640x480, the aspect ratio is 4:3. This above aspect ratio has been found to appear as a natural image.

### 8-Bit Gray Level Image

An 8-bit image is an image where each pixel has an 8-bit value (0-255) represented by a byte, which is also known as Grayscale. Thus, the image can be a 2-dimensional array of values, ranging between (0-255), which is also referred to as a bit map.

For Example: An 8-bit Grayscale of VGA resolution would be the size of 300 Kbytes.

### Image Data Type for Color Images

The common data type for graphics and image file formats is 24-bit color or 8-bit color. In a 24-bit color image data type, each pixel is represented by three

bytes, one for the RGB of each primary color. The other colors are represented as a combination of the RGB values. Because each value is in the range of 0-255, it provides a total of 16,777,216 possible colors; however, this requires a huge storage memory (16 Mbytes).

For example, for a resolution of 640x480, a 24-bit color image would require 900 Kbytes of memory (without any compression).

If memory space is a concern (which is generally the case), by quantizing the 24-bit color information, reasonably accurate 8-bit color information can be achieved. This also means that we have only 256 possible colors.

### 8-Bit Color Image Files

Image files use a special concept to store color information in a CLUT. The image is not represented by colors but a set of bytes. These bytes form the index to a table, which has 3-byte values that specify the color for a pixel. This means the user has to represent the image by choosing the colors that best represent the image and does not exceed the 256 color combinations, as they are indexed by 8-bit values.

One important savings of 8-bit representation over 24-bit representation is in storage space, which is 300 Kbytes vs. 900 Kbytes (with no compression applied).

Figure A-1 can help in understanding the CLUT, which is also known as a palette table.

FIGURE A-1: COLOR LOOK-UP TABLE (CLUT)

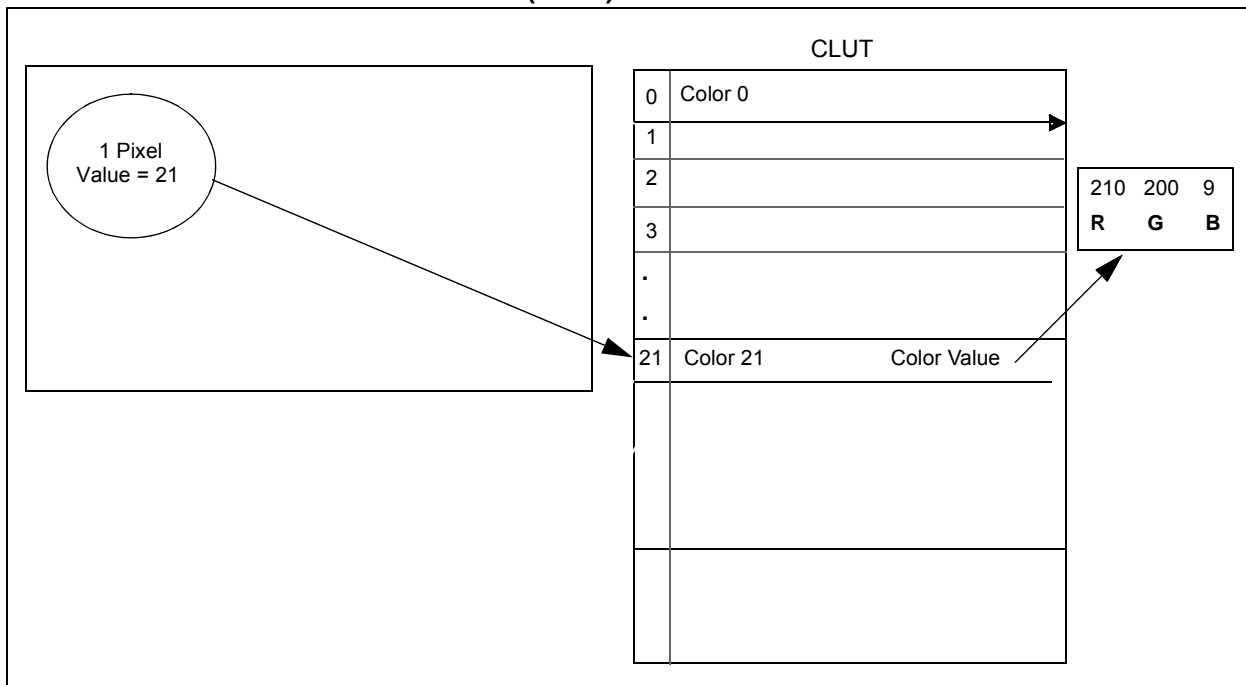


Figure A-1 shows a pixel which has RGB and it is represented by a value of 21. The value, 21, in a look-up table, indexes the 24-bit RGB value for that pixel.

Table A-1 represents the image using indexes instead of RGB values from the palette table, as shown in Table A-2.

**TABLE A-1: CONTENTS OF AN EXAMPLE IMAGE USING INDEXES INSTEAD OF RGB VALUES**

0	0	0	0	1	1	1	1
0	0	0	0	1	1	1	1
0	0	0	0	1	1	1	1
0	0	0	0	1	1	1	1
2	2	2	2	3	3	3	3
2	2	2	2	3	3	3	3
2	2	2	2	3	3	3	3
2	2	2	2	3	3	3	3

**TABLE A-2: PALETTE TABLE (24 BPP)**

Color Index	R	G	B
0	0	255	0
1	255	0	0
2	0	0	255
3	0	255	255
.	.	.	.
.	.	.	.
255	219	200	198

**Note:** A color index refers to one row of CLUT.

A simple color changing type of animation process is possible by changing the CLUT in the above method. This is also known as palette animation.

In the above explanation, we saw a simple way to cluster the image and device a CLUT, but clustering is a slow process.

The other way to device a CLUT is to scale the RGB ranges to generate the 16-bit codes. However, since the human eye is more sensitive to Green, we can give Red and Blue 5 bits each, with 6 bits for Green, and each cell in the image gets replaced by its index. This may lead to edge artifacts in the image. Therefore, this is not suitable for natural images but may be suitable for artificially created images.

PIC24FJ256DA210 supports up to a 256-entry CLUT with 16 BPP per entry.

## Median Cut Algorithm

It is an adaptive method that tries to put most bits where colors are most clustered, so that they can be discriminated. This is the most general algorithm used while converting a RGB image to a CLUT-based color image, such as PC applications (e.g., GIMP).

## APPENDIX B: DOUBLE-BUFFERING

Manipulating pixels on the screen requires direct writes to the frame buffer. While these changes are being executed, the screen is also refreshed. This means that the changes are displayed immediately as the frame buffer is being updated. This is not a suitable scheme when the changes are slow, for example, decoding an image or having a large number of widgets on a screen. The display may appear slow in that case and can cause user dissatisfaction.

One solution to this problem is to use a double-buffering scheme supported by the Microchip Graphics Library. In this scheme, the changes are not directly written to the frame buffer, but instead, they are written to a separate buffer, called the 'Draw Buffer'. After all the changes are made, the draw buffer and frame buffer are exchanged. Now the draw buffer becomes the frame buffer, and because of all the changes drawn there, the changes appear spontaneous to the user. Of course, there will be a delay, as all the changes have to be written to the draw buffer before displaying it. This delay is generally more tolerable than displaying the changes slowly.

After exchanging of the buffers, the latest buffer (which is now the frame buffer) is copied to the new draw buffer in the background, then the new draw buffer is in sync with what is being displayed. New changes are then written to the draw buffer and the cycle continues.

As the double-buffering scheme uses two buffers, the RAM requirement will double.

In the Microchip Graphics Library, if double-buffering is enabled, the frame buffer and draw buffer are exchanged after the changes of all the widgets on a screen are done (i.e., the new screen appears after the whole screen is updated and not after updating an individual widget).

The workflow of double-buffering is as follows:

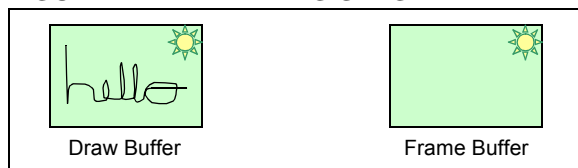
1. In the initial stage, the draw buffer and frame buffer have the same contents, as shown in [Figure B-1](#).

**FIGURE B-1: INITIAL STAGE**



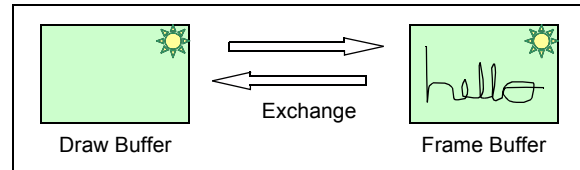
2. In the drawing stage, only the draw buffer is modified, and therefore, the frame buffer is not visible to the user, as shown in [Figure B-2](#).

**FIGURE B-2: DRAWING STAGE**



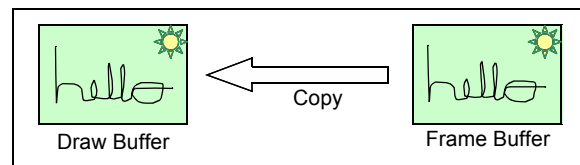
3. In the swap stage, the draw buffer is swapped with the frame buffer (by exchange of pointers), as shown in [Figure B-3](#).

**FIGURE B-3: SWAP STAGE**



4. In the final stage, the frame buffer is copied to the draw buffer, so the buffers have the same contents, as shown in [Figure B-4](#).

**FIGURE B-4: FINAL STAGE**



5. The workflow cycle continues.

### When to Use Double-Buffering?

Use double-buffering when:

- There are large numbers of widgets on a screen
- The decoding and displaying of images are required
- The display resolution is larger than the WQVGA, even if the above points do not hold true

### When Not to Use Double-Buffering?

Do not use double-buffering when:

- The immediate display of changes is required. For example, plotting a graph.
- The RAM available for display is limited.
- The display resolution is smaller than the WQVGA (this is not a hard rule).

### How to Use Double-Buffering?

Double-buffering can be used as follows:

- Enable double-buffering by defining, `USE_DOUBLE_BUFFERING` in the `GraphicsConfig.h`.
- See the section on double-buffering in the Microchip Graphics Library Help file for code examples.

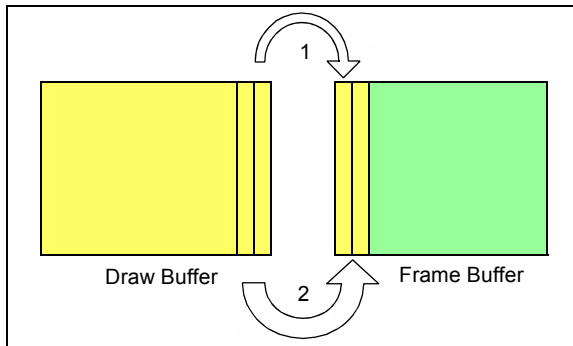
## APPENDIX C: ADVANCED USAGE OF RCCGPU

The RCCGPU can be used to achieve different kinds of graphical effects, for instance, animations and scrolling screens. These effects are achieved using a buffer of memory, that is separate from the frame buffer, which contains the final image to be displayed on the screen. The image from this buffer is then transferred to the frame buffer in special ways which forms the various visual effects on the screen. For example, transferring the image vertically, line by line to the frame buffer, gives the effect of peeling, whereas moving the existing frame buffer, line by line, and filling the moved part with the final image, gives the effect of scrolling the screen.

Some of the effects and their algorithm are as follows:

1. Move from Left to Right: This effect shows the new screen sliding from left to right.

**FIGURE C-1: MOVE FROM LEFT TO RIGHT**



**Algorithm:**

**Step i:** The new screen is completely created in the draw buffer.

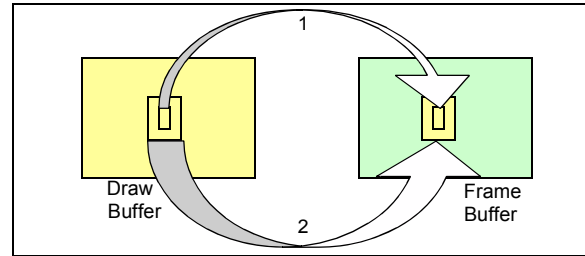
**Step ii:** Move one right line (Height = Screen Height, Width = One Pixel) from the draw buffer to the left side of the frame buffer using the RCCGPU rectangle copy command.

**Step iii:** Move two right lines (Height = Screen Height, Width = 2 Pixels) from the draw buffer to the left side of the frame buffer using the RCCGPU rectangle copy command.

Repeat the above steps until the whole screen is transferred to the frame buffer, as shown in [Figure C-1](#).

2. Expanding Rectangle: This effect shows a rectangle expanding from the middle to the periphery of the screen.

**FIGURE C-2: EXPANDING RECTANGLE**



**Algorithm:**

**Step i:** The new screen is completely created in the draw buffer.

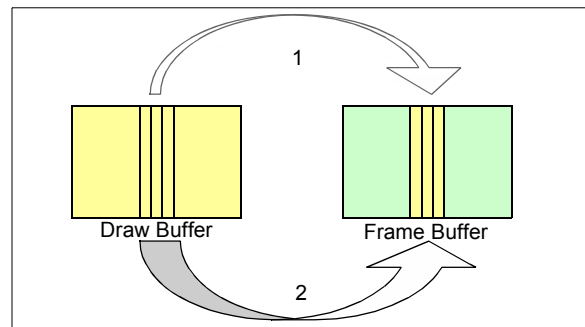
**Step ii:** Move a rectangle of 2x2 from the middle of the draw buffer to the middle of the frame buffer using the RCCGPU rectangle copy command.

**Step iii:** Move a rectangle of 3x3 from the middle of the draw buffer to the middle of the frame buffer using the RCCGPU rectangle copy command.

Repeat the above steps until the whole screen is transferred to the frame buffer, as shown in [Figure C-2](#).

3. Expanding Line: This effect shows a vertical line expanding from the middle to the end in a horizontal direction.

**FIGURE C-3: EXPANDING LINE**



**Algorithm:**

**Step i:** The new screen to be shown is completely created in the draw buffer.

**Step ii:** Move two middle lines (Height = Screen Height, Width = 2 Pixels) from the draw buffer to the middle of the frame buffer using the RCCGPU rectangle copy command.

**Step iii:** Move four middle lines (Height = Screen Height, Width = 4 Pixels) from the draw buffer to the middle of the frame buffer using the RCCGPU rectangle copy command.

Repeat the above steps until the whole screen is transferred to the frame buffer, as shown in [Figure C-3](#). Similarly, many screen transition effects can be achieved easily.

## APPENDIX D: ABBREVIATIONS

Table D-1 lists the abbreviations used in this document.

**TABLE D-1: ABBREVIATIONS**

Abbreviation	Definition
1 Kbyte	1024 Bytes
AMOLED	Active-Matrix Organic Light-Emitting Diode
CCFL	Cold Cathode Fluorescent Lamps
CHRGPU	Character Graphics Processing Unit
CIF	Common Intermediate Format
CLUT	Color Look-up Table
CSTN	Color Super-Twisted Nematic
DRAM	Dynamic Random Access Memory
EPMP	Enhanced Parallel Master Port
GPU	Graphical Processing Unit
GUI	Graphical User Interface
HBLANK	Horizontal Blanking
IC	Integrated Circuit
IPU	Inflate Processing Unit
LCD	Liquid Crystal Display
LED	Light-Emitting Diode
MIPS	Million Instructions per Second
MSTN	Monochrome Super-Twisted Nematic
OLED	Organic Light-Emitting Diode
PCB	Printed Circuit Board
PMP	Parallel Master Port
QCIF	Quarter Common Intermediate Format
QVGA	Quarter Video Graphics Array
RCCGPU	Rectangle Copy Graphics Processing Unit
RGB	Red Green Blue
RTCC	Real-Time Clock and Calendar
STN	Super-Twisted Nematic
TFT-LCD	Thin Film Transistor Liquid Crystal Display
UART	Universal Asynchronous Receiver/Transmitter
USB	Universal Serial Bus
VBLANK	Vertical Blanking
VGA	Video Graphics Array
WQVGA	Wide Quarter Video Graphics Array

## REFERENCES

For additional information on the use of the Microchip Graphics Library, refer to following application notes:

- , AN1136, "How to Use Widgets in Microchip Graphics Library" (DS01136), Paolo Tamayo, Microchip Technology Inc., 2007.
- , AN1246 "How to Create Widgets in Microchip Graphics Library" (DS01246), Paolo Tamayo and Harold Serrano, Microchip Technology Inc., 2009.
- AN1227, "Using a Keyboard with the Microchip Graphics Library" (DS01227), Anton Alkhimenok, Microchip Technology Inc., 2008.
- AN1182 "Fonts in the Microchip Graphics Library" (DS01182), Paolo Tamayo, Microchip Technology Inc., 2010.
- DEFLATE Compressed Data Format Specification (RFC1951) — <http://www.ietf.org/rfc/rfc1951.txt>

**For additional information on Microchip products or graphics applications, refer to the link:**

<http://www.microchip.com/graphics>

---

**Note the following details of the code protection feature on Microchip devices:**

- Microchip products meet the specification contained in their particular Microchip Data Sheet.
- Microchip believes that its family of products is one of the most secure families of its kind on the market today, when used in the intended manner and under normal conditions.
- There are dishonest and possibly illegal methods used to breach the code protection feature. All of these methods, to our knowledge, require using the Microchip products in a manner outside the operating specifications contained in Microchip's Data Sheets. Most likely, the person doing so is engaged in theft of intellectual property.
- Microchip is willing to work with the customer who is concerned about the integrity of their code.
- Neither Microchip nor any other semiconductor manufacturer can guarantee the security of their code. Code protection does not mean that we are guaranteeing the product as “unbreakable.”

Code protection is constantly evolving. We at Microchip are committed to continuously improving the code protection features of our products. Attempts to break Microchip's code protection feature may be a violation of the Digital Millennium Copyright Act. If such acts allow unauthorized access to your software or other copyrighted work, you may have a right to sue for relief under that Act.

---

Information contained in this publication regarding device applications and the like is provided only for your convenience and may be superseded by updates. It is your responsibility to ensure that your application meets with your specifications. MICROCHIP MAKES NO REPRESENTATIONS OR WARRANTIES OF ANY KIND WHETHER EXPRESS OR IMPLIED, WRITTEN OR ORAL, STATUTORY OR OTHERWISE, RELATED TO THE INFORMATION, INCLUDING BUT NOT LIMITED TO ITS CONDITION, QUALITY, PERFORMANCE, MERCHANTABILITY OR FITNESS FOR PURPOSE. Microchip disclaims all liability arising from this information and its use. Use of Microchip devices in life support and/or safety applications is entirely at the buyer's risk, and the buyer agrees to defend, indemnify and hold harmless Microchip from any and all damages, claims, suits, or expenses resulting from such use. No licenses are conveyed, implicitly or otherwise, under any Microchip intellectual property rights.

**Trademarks**

The Microchip name and logo, the Microchip logo, dsPIC, KEELOQ, KEELOQ logo, MPLAB, PIC, PICmicro, PICSTART, PIC<sup>32</sup> logo, rPIC and UNI/O are registered trademarks of Microchip Technology Incorporated in the U.S.A. and other countries.


FilterLab, Hampshire, HI-TECH C, Linear Active Thermistor, MXDEV, MXLAB, SEEVAL and The Embedded Control Solutions Company are registered trademarks of Microchip Technology Incorporated in the U.S.A.

Analog-for-the-Digital Age, Application Maestro, CodeGuard, dsPICDEM, dsPICDEM.net, dsPICworks, dsSPEAK, ECAN, ECONOMONITOR, FanSense, HI-TIDE, In-Circuit Serial Programming, ICSP, Mindi, MiWi, MPASM, MPLAB Certified logo, MPLIB, MPLINK, mTouch, Omniscient Code Generation, PICC, PICC-18, PICDEM, PICDEM.net, PICkit, PICTail, REAL ICE, rLAB, Select Mode, Total Endurance, TSHARC, UniWinDriver, WiperLock and ZENA are trademarks of Microchip Technology Incorporated in the U.S.A. and other countries.

SQTP is a service mark of Microchip Technology Incorporated in the U.S.A.

All other trademarks mentioned herein are property of their respective companies.

© 2011, Microchip Technology Incorporated, Printed in the U.S.A., All Rights Reserved.

 Printed on recycled paper.

ISBN: 978-1-61341-123-0

*Microchip received ISO/TS-16949:2002 certification for its worldwide headquarters, design and wafer fabrication facilities in Chandler and Tempe, Arizona; Gresham, Oregon and design centers in California and India. The Company's quality system processes and procedures are for its PIC<sup>®</sup> MCUs and dsPIC<sup>®</sup> DSCs, KEELOQ<sup>®</sup> code hopping devices, Serial EEPROMs, microperipherals, nonvolatile memory and analog products. In addition, Microchip's quality system for the design and manufacture of development systems is ISO 9001:2000 certified.*

**QUALITY MANAGEMENT SYSTEM  
CERTIFIED BY DNV  
== ISO/TS 16949:2002 ==**



# MICROCHIP

## Worldwide Sales and Service

### AMERICAS

**Corporate Office**  
2355 West Chandler Blvd.  
Chandler, AZ 85224-6199  
Tel: 480-792-7200  
Fax: 480-792-7277  
Technical Support:  
<http://www.microchip.com/support>  
Web Address:  
[www.microchip.com](http://www.microchip.com)

**Atlanta**  
Duluth, GA  
Tel: 678-957-9614  
Fax: 678-957-1455

**Boston**  
Westborough, MA  
Tel: 774-760-0087  
Fax: 774-760-0088

**Chicago**  
Itasca, IL  
Tel: 630-285-0071  
Fax: 630-285-0075

**Cleveland**  
Independence, OH  
Tel: 216-447-0464  
Fax: 216-447-0643

**Dallas**  
Addison, TX  
Tel: 972-818-7423  
Fax: 972-818-2924

**Detroit**  
Farmington Hills, MI  
Tel: 248-538-2250  
Fax: 248-538-2260

**Indianapolis**  
Noblesville, IN  
Tel: 317-773-8323  
Fax: 317-773-5453

**Los Angeles**  
Mission Viejo, CA  
Tel: 949-462-9523  
Fax: 949-462-9608

**Santa Clara**  
Santa Clara, CA  
Tel: 408-961-6444  
Fax: 408-961-6445

**Toronto**  
Mississauga, Ontario,  
Canada  
Tel: 905-673-0699  
Fax: 905-673-6509

### ASIA/PACIFIC

**Asia Pacific Office**  
Suites 3707-14, 37th Floor  
Tower 6, The Gateway  
Harbour City, Kowloon  
Hong Kong  
Tel: 852-2401-1200  
Fax: 852-2401-3431

**Australia - Sydney**  
Tel: 61-2-9868-6733  
Fax: 61-2-9868-6755

**China - Beijing**  
Tel: 86-10-8528-2100  
Fax: 86-10-8528-2104

**China - Chengdu**  
Tel: 86-28-8665-5511  
Fax: 86-28-8665-7889

**China - Chongqing**  
Tel: 86-23-8980-9588  
Fax: 86-23-8980-9500

**China - Hong Kong SAR**  
Tel: 852-2401-1200  
Fax: 852-2401-3431

**China - Nanjing**  
Tel: 86-25-8473-2460  
Fax: 86-25-8473-2470

**China - Qingdao**  
Tel: 86-532-8502-7355  
Fax: 86-532-8502-7205

**China - Shanghai**  
Tel: 86-21-5407-5533  
Fax: 86-21-5407-5066

**China - Shenyang**  
Tel: 86-24-2334-2829  
Fax: 86-24-2334-2393

**China - Shenzhen**  
Tel: 86-755-8203-2660  
Fax: 86-755-8203-1760

**China - Wuhan**  
Tel: 86-27-5980-5300  
Fax: 86-27-5980-5118

**China - Xian**  
Tel: 86-29-8833-7252  
Fax: 86-29-8833-7256

**China - Xiamen**  
Tel: 86-592-2388138  
Fax: 86-592-2388130

**China - Zhuhai**  
Tel: 86-756-3210040  
Fax: 86-756-3210049

### ASIA/PACIFIC

**India - Bangalore**  
Tel: 91-80-3090-4444  
Fax: 91-80-3090-4123

**India - New Delhi**  
Tel: 91-11-4160-8631  
Fax: 91-11-4160-8632

**India - Pune**  
Tel: 91-20-2566-1512  
Fax: 91-20-2566-1513

**Japan - Yokohama**  
Tel: 81-45-471- 6166  
Fax: 81-45-471-6122

**Korea - Daegu**  
Tel: 82-53-744-4301  
Fax: 82-53-744-4302

**Korea - Seoul**  
Tel: 82-2-554-7200  
Fax: 82-2-558-5932 or  
82-2-558-5934

**Malaysia - Kuala Lumpur**  
Tel: 60-3-6201-9857  
Fax: 60-3-6201-9859

**Malaysia - Penang**  
Tel: 60-4-227-8870  
Fax: 60-4-227-4068

**Philippines - Manila**  
Tel: 63-2-634-9065  
Fax: 63-2-634-9069

**Singapore**  
Tel: 65-6334-8870  
Fax: 65-6334-8850

**Taiwan - Hsin Chu**  
Tel: 886-3-6578-300  
Fax: 886-3-6578-370

**Taiwan - Kaohsiung**  
Tel: 886-7-213-7830  
Fax: 886-7-330-9305

**Taiwan - Taipei**  
Tel: 886-2-2500-6610  
Fax: 886-2-2508-0102

**Thailand - Bangkok**  
Tel: 66-2-694-1351  
Fax: 66-2-694-1350

### EUROPE

**Austria - Wels**  
Tel: 43-7242-2244-39  
Fax: 43-7242-2244-393

**Denmark - Copenhagen**  
Tel: 45-4450-2828  
Fax: 45-4485-2829

**France - Paris**  
Tel: 33-1-69-53-63-20  
Fax: 33-1-69-30-90-79

**Germany - Munich**  
Tel: 49-89-627-144-0  
Fax: 49-89-627-144-44

**Italy - Milan**  
Tel: 39-0331-742611  
Fax: 39-0331-466781

**Netherlands - Drunen**  
Tel: 31-416-690399  
Fax: 31-416-690340

**Spain - Madrid**  
Tel: 34-91-708-08-90  
Fax: 34-91-708-08-91

**UK - Wokingham**  
Tel: 44-118-921-5869  
Fax: 44-118-921-5820

02/18/11

## Looking for pricing, stock, or lifecycle information?

Click below to explore more details on WIN SOURCE:

- ⊖ [View AC164127-7 on WIN SOURCE](#)
- ⊖ [Microchip Technology](#) Information

## Optimize Your Supply Chain with WIN SOURCE Solutions

- ✓ Global Sourcing Solution
- ✓ Obsolete Management
- ✓ Cost Control Management
- ✓ Shortage Management
- ✓ Alternative Solution
- ✓ Excess Inventory Management