

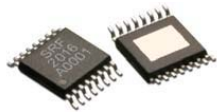

THE DATASHEET OF SRF-2016





RoHS Compliant and Pb-Free Product (Z Part Number)
 Package: TSSOP, 16-Pin, 5.0mmx6.4mmx1.0mm

Product Description

RFMD's SRF-2016 is a quadrature demodulator RFIC designed for UHF and microwave receiver IF applications. This device features switchable gain control, high P1dB, and excellent I/Q amplitude and phase balance. Use of this highly integrated device can result in lower component count, a more compact assembly, and higher transceiver card yields. The device is packaged in an industry standard 16-pin TSSOP with exposed paddle for superb RF and thermal ground.

Features

- Gain Control in 20dB Steps
- Excellent I/Q Amplitude and Phase Balance
- Output $P_{1dB} > +4$ dBm Over All Gain Settings

Applications

- Digital and Spread Spectrum Communication Systems
- Cellular, PCS, DCS, 2G, 2.5G, 3G Transceivers
- ISM Band Transceivers
- Point-to-Point Microwave Receivers
- Broadband Wireless Systems

Optimum Technology Matching® Applied

- GaAs HBT
- GaAs MESFET
- InGaP HBT
- SiGe BiCMOS
- Si BiCMOS
- SiGe HBT
- GaAs pHEMT
- Si CMOS
- Si BJT
- GaN HEMT
- RF MEMS

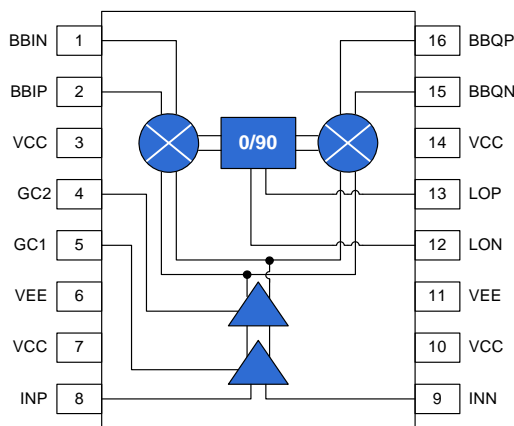

Parameter	Specification			Unit	Condition
	Min.	Typ.	Max.		
I/Q Output					
I/Q Output Frequency Range	DC		500	MHz	
I/Q Output Amplitude Balance	-0.2		0.2	dB	
I/Q Output Phase Balance	-2		+2	°C	
I/Q Output Common-mode Voltage		2.5		V	
I/Q Output Return Loss		20		dB	50Ω nominal differential output
LO Input					
LO Frequency Range	200		600	MHz	
LO Input Level	-3	0	+3	dBm	
LO Return Loss		20		dB	50Ω nominal differential input, Note 1
IF Input					
IF Frequency Range	200		600	MHz	
INP/INN Return Loss		20		dB	50Ω nominal differential input, Note 2
INP/INN Common Mode Voltage		2		V	Internally generated
Gain	28	30	32	dB	High gain setting GC1=GC2=+5V
Input P1dB	-27	-25		dBm	
Input IP2		+13		dBm	
Input IP3		-14		dBm	
DSB Noise Figure		14		dB	

Note 1: To achieve 20dB port match above 100MHz the parasitic inductance of the package must be matched out.

Note 2: To achieve 20dB of port match the parasitic inductance of the package, board, and L4, L5 must be matched out at the center frequency with a series capacitor.

Absolute Maximum Ratings

Parameter	Rating	Unit
Supply Voltage	6.0	VDC
LO Input	+10	dBm
IF Input	+10	dBm
Operating Temperature	-40 to +85	°C
Storage Temperature	-65 to +150	°C

Operation of this device beyond any one of these limits may cause permanent damage. For reliable continuous operation, the device voltage and current must not exceed the maximum operating values specified in the table on page one.



Caution! ESD sensitive device.

Exceeding any one or a combination of the Absolute Maximum Rating conditions may cause permanent damage to the device. Extended application of Absolute Maximum Rating conditions to the device may reduce device reliability. Specified typical performance or functional operation of the device under Absolute Maximum Rating conditions is not implied.

RoHS status based on EU Directive 2002/95/EC (at time of this document revision).

The information in this publication is believed to be accurate and reliable. However, no responsibility is assumed by RF Micro Devices, Inc. ("RFMD") for its use, nor for any infringement of patents, or other rights of third parties, resulting from its use. No license is granted by implication or otherwise under any patent or patent rights of RFMD. RFMD reserves the right to change component circuitry, recommended application circuitry and specifications at any time without prior notice.

Parameter	Specification			Unit	Condition
	Min.	Typ.	Max.		
IF Input, cont.					
Gain	10	12	14	dB	Medium gain setting GC1 = +5V GC2 = +0V
Input P1dB	-9	-7		dBm	
Input IP2		+41		dBm	
Input IP3		+3		dBm	
DSB Noise Figure		17		dB	
Gain	-7	-5	-3	dB	Low gain setting GC1 = GC2 = 0V
Input P1dB	10	12		dBm	
Input IP2		+49		dBm	
Input IP3		+24		dBm	
DSB Noise Figure		33		dB	
Miscellaneous					
Supply Voltage (V _{CC})	+4.75	+5.00	+5.25	V	
Supply Current (I _{CC})		195		mA	
Thermal Resistance		35	45	°C/W	Hot spot on die to lead
GC1, GC2 Input V _{IL}	0		0.3xV _{CC}	V	Logic level zero
GC1, GC2 Input V _{IH}	0.7xV _{CC}		V _{CC}	V	Logic level one
GC1, GC2 Input Impedance	40			kΩ	

Test Conditions

Gain State	GC1 Voltage	GC2 Voltage	IF Power
Low Gain	0V	0V	0dBm
Medium Gain	+5V	0V	-20dBm
High Gain	+5V	+5V	-40dBm

V_{CC} = +5V_{DC}, T = +25°C, LO input = 0dBm, 400MHz, IF input = 401MHz

The SRF-2016 is a variable gain I-Q demodulator designed for use in receiver IF sections, as shown in the figure below. It consists of five subcircuits: two cascaded switched gain stages, a matched pair of mixers, and a LO quadrature generator. This part is also available in a higher frequency version, the SRF-1016.

The gain stages are broadband differential amplifiers each with a digital control pin to set the gain. The gain control pins act independently of each other. Since the amplifiers have approximately the same gain, setting GC1 high and GC2 low results in approximately the same gain as setting GC1 low and GC2 high. The former setting is preferred because it offers better noise figure. The IF input is differential with internal bias circuitry to set the common mode voltage. The use of blocking capacitors to facilitate AC coupling is highly recommended to avoid changing the common mode voltage. Either input may be driven single-ended if the other input is connected to ground through an AC short such as a 1000pF capacitor. This typically results in slightly lower input P_{1dB} .

The two matched mixers are configured with the quadrature LO generator to provide in-phase and quadrature baseband outputs. These can be fed through ADCs to a DSP engine, or can be fed into a low frequency 90° hybrid for image rejection. Alternatively, the IF signal can be extracted from the BBI port by injecting DC into the LO port.

The LO and IF ports offer a differential 50Ω impedance. The package (and in the case of the input port, the parallel L-R network) adds inductance that tends to degrade return loss. This can easily be matched out with a series capacitor. The 8.2pF capacitor on the evaluation board is appropriate for 400MHz operation; larger capacitors should be used for lower frequencies.

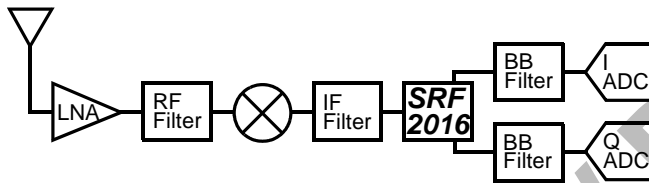

Typical use for the SRF-2016 in a receiver employing digital I/Q demodulation.

The SRF-2016 has high gain at UHF frequencies, so instability can result if there is poor power supply decoupling or undesired coupling from the input to the output. The following considerations should be observed when laying out a PC board:

Follow the general layout of the evaluation board, keeping the power supply decoupling capacitors as close to the package as possible. The back of the package, the two ground pins and the decoupling capacitors should connect directly to ground, preferably to a large dedicated ground plane. Use the parallel L-R circuits on the input pins. Ensure that the input signal tracks are routed far from the output tracks. The V_{CC} pins are not internally connected, so all must be connected together externally with the specified decoupling capacitors.

The figures on page 4 illustrate a typical SRF-2016's performance with respect to temperature. Note that these numbers include the effect of the R-L network in the IF port.

The frequency response of the IF and LO ports is dominated by the L-R network on the input. When de-embedded, the gain and P_{1dB} response is within 0.5dB from 200MHz to 600MHz.

The SRF-2016 features immunity from changes in LO power. The gain typically changes by less than 0.6dB over a 6dB range of LO power. Also note the excellent I/Q balance, which typically falls within 0.15dB and 1.5° from 200MHz to 600MHz, and varies less than 0.05dB and 0.5° over temperature (-40 to +85C).

The package dimensions are shown on page 5. Note that heat is removed from the part via the heat slug, so this slug must be properly soldered to a copper plane under the part.

Evaluation boards are available for this device and a description of the board are shown on page 6. Note that the evaluation board uses baluns on the I/Q outputs, and these baluns limit the low frequency response of the device. For true baseband operation, the baluns should be removed, and the differential signals used directly.

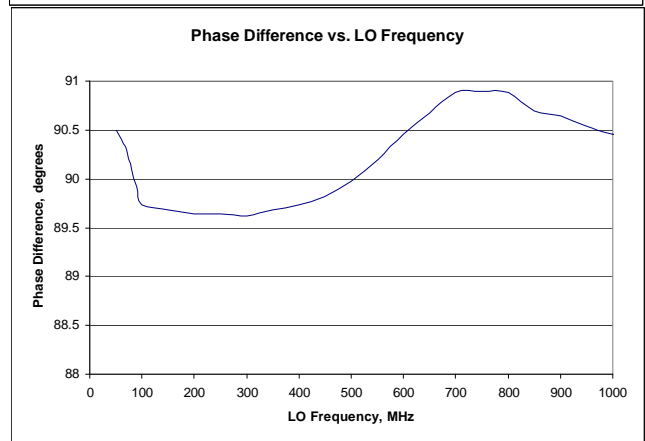
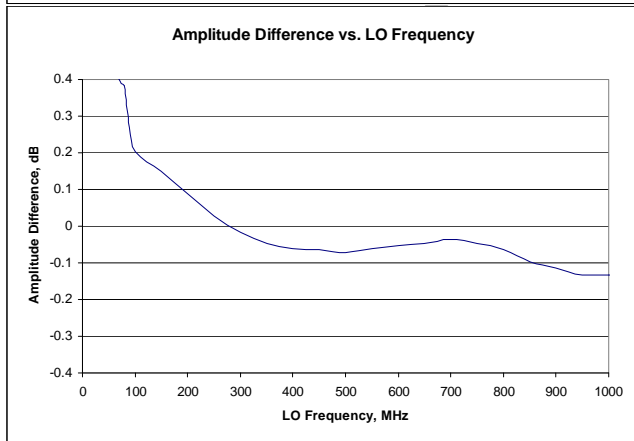
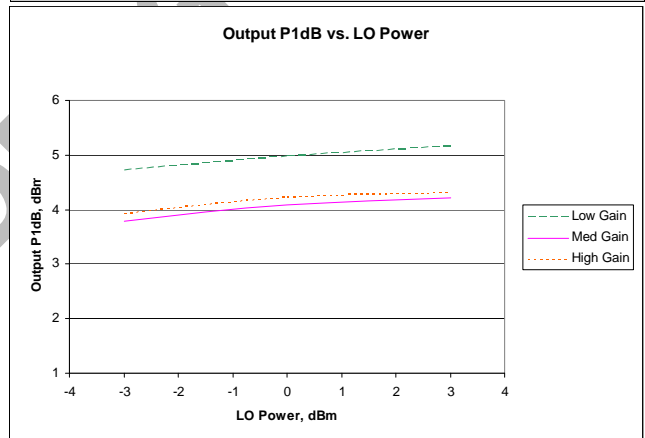
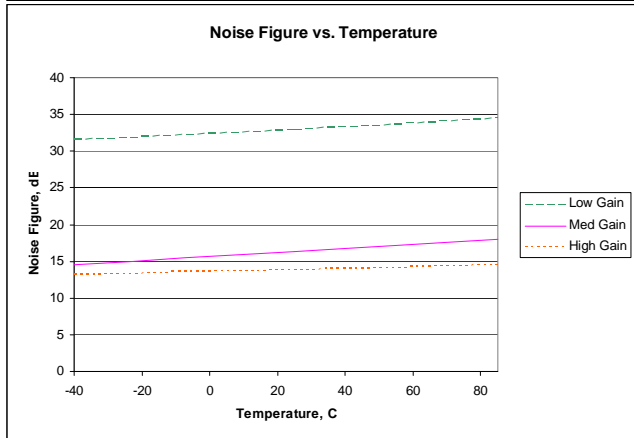
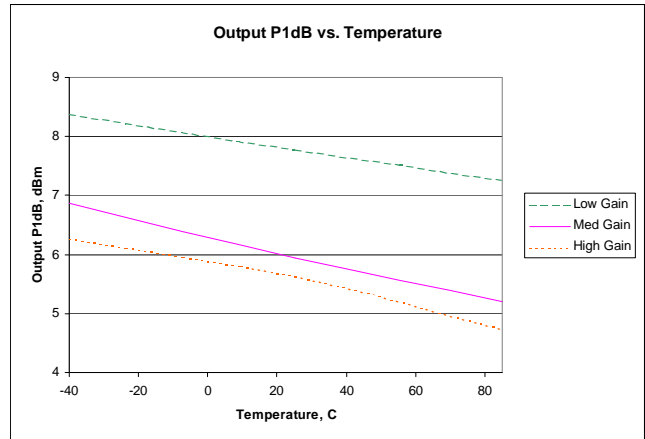
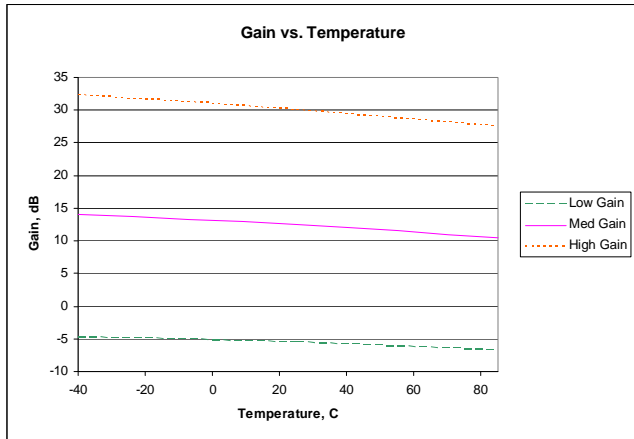

Pin	Function	Description
1	BBIN	Baseband i-axis output (-). Self-biasing.
2	BBIP	Baseband I-axis output (+). Self-biasing.
3, 7, 10, 14	VCC	Positive power supply.
4	GC2	Gain control input, stage 2. 5V CMOS levels.
5	GC1	Gain control input, stage 1. 5V CMOS levels.
6, 11	VEE	Ground.
8	INP	IF input (+). Self-biasing; AC-couple.
9	INN	IF input (-). Self-biasing; AC-couple.
12	LON	LO input (-). Self-biasing; AC-couple.
13	LOP	LO input (+). Self-biasing; AC-couple.
15	BBQN	Baseband Q-axis output (-). Self-biasing.
16	BBQP	Baseband Q-axis output (+). Self-biasing.

Suggested Pad Layout

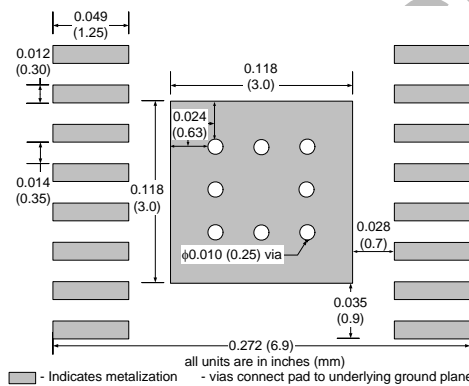

Package Drawing

Dimensions in inches (millimeters)

Refer to drawing posted at www.rfmd.com for tolerances.

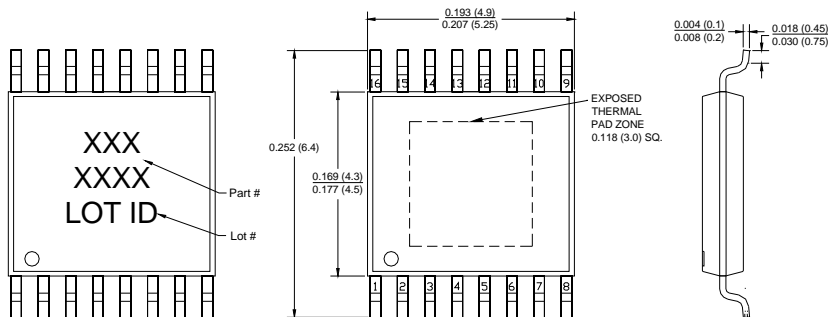

- NOTES:
1. PACKAGE BODY SIZES EXCLUDE MOLD FLASH PROTRUSIONS OR GATE BURRS.
 2. TOLERANCE ±0.1MM UNLESS OTHERWISE SPECIFIED.
 3. COPLANARITY: 0.1MM
 4. CONTROLLING DIMENSION IS MILLIMETER. CONVERTED INCH DIMENSIONS ARE NOT NECESSARILY EXACT.
 5. FOLLOWED FROM JEDEC MO-153.

Fully Assembled PCB

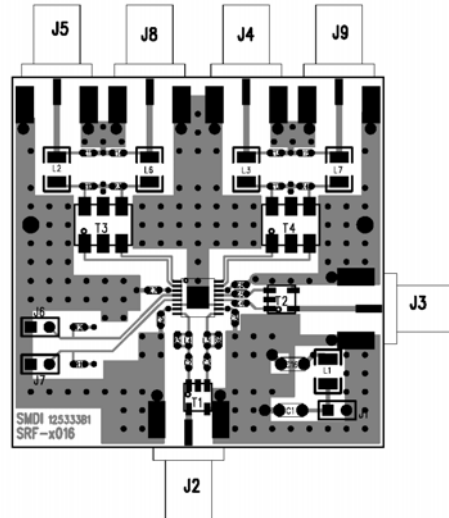

Evaluation Board Schematic

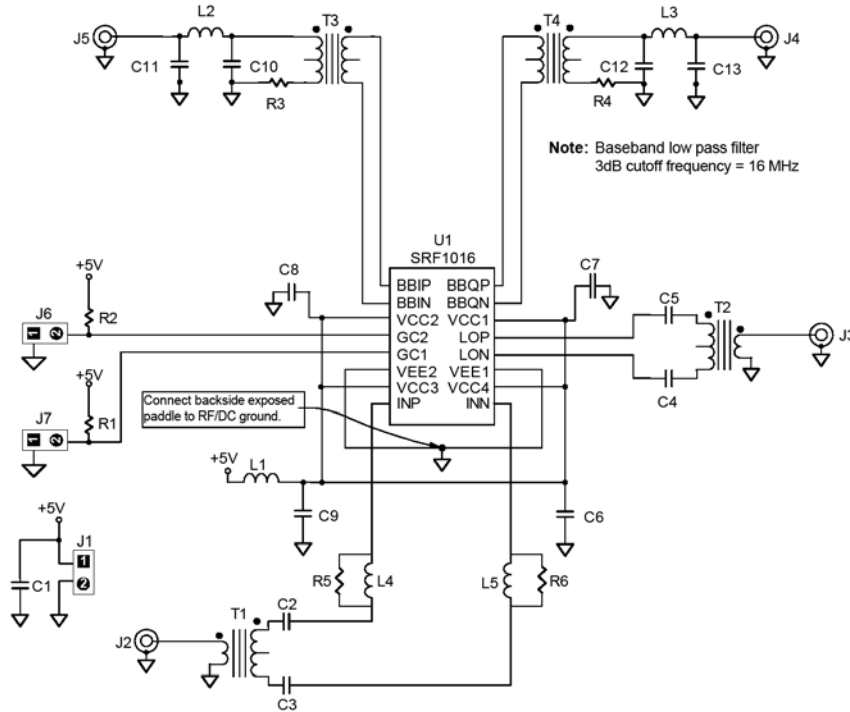

NO1

Bill of Materials (P/N SRF2016EVB, 400 MHz Evaluation Board)

Component Designator	Value	Qty	Vendor	Part Number	Description
PCB		1	SMDI	125333B1	Printed Circuit Board
U1		1	SMDI	SRF-2016	IF receiver
J1, J6, J7		3	Sullins	S1312-02-ND	2 pin 0.1" header
J2, J3, J4, J5		4	Johnson Components	142-0701-851	SMA end launch connector
T1, T2		2	Mini-Circuits	TC1-1	IF Transformer
T3, T4		2	Mini-Circuits	ADT1-6T	Baseband Transformer
C1	1uF	1	Venkel	C1206Y5V160-105ZNE	1206 size supply bypass capacitor
C2, C3	8.2pF	2	Venkel	C0603COG500-8R2JNE	0603 size coupling capacitor
C4, C5	15pF	2	Venkel	C0603COG500-150JNE	0603 size coupling capacitor
C9	100pF	1	Venkel	C0603COG500-101JNE	0603 size bypass capacitor
C6, C7, C8	22pF	3	Venkel	C0603COG500-220JNE	0603 size bypass capacitor
C10, C11, C12, C13	220pF	4	Venkel	C0603COG500-221JNE	0603 size filter capacitor
L1, L2, L3	1uH	5	Panasonic	PCD1008TR-ND	1210 size filter inductor
R1, R2	1kOhm	2	Venkel	CR0603-16W-102JT	0603 size pull-up resistor
R3, R4	0Ohm	2	Venkel	CR0603-16W-000T	0603 jumper
R5, R6	500hm	2	Venkel	CR0603-16W-500JT	0603 size stability resistor
L4, L5	10nH	2	Toko	LL1608 FS10NJ	0603 size stability inductor

Bill of Materials (P/N SRF-2016EVB-1, 300 MHz Evaluation Board)

Component Designator	Value	Qty	Vendor	Part Number	Description
PCB		1	SMDI	125333B1	Printed Circuit Board
U1		1	SMDI	SRF-2016	IF receiver
J1, J6, J7		3	Sullins	S1312-02-ND	2 pin 0.1" header
J2, J3, J4, J5		4	Johnson Components	142-0701-851	SMA end launch connector
T1, T2		2	Mini-Circuits	TC1-1	IF Transformer
T3, T4		2	Mini-Circuits	ADT1-6T	Baseband Transformer
C1	1 uF	1	Venkel	C1206Y5V160-105ZNE	1206 size supply bypass capacitor
C2, C3	12 pF	2	Murata	GRM39COG120J050AD	0603 size coupling capacitor
C4, C5	18 pF	2	Murata	GRM39COG180J050AD	0603 size coupling capacitor
C9	100 pF	1	Venkel	C0603COG500-101JNE	0603 size bypass capacitor
C6, C7, C8	22 pF	3	Venkel	C0603COG500-220JNE	0603 size bypass capacitor
C10, C11, C12, C13	220 pF	4	Venkel	C0603COG500-221JNE	0603 size filter capacitor
L1, L2, L3	1 uH	5	Panasonic	PCD1008TR-ND	1210 size filter inductor
R1, R2	1 kOhm	2	Venkel	CR0603-16W-102JT	0603 size pull-up resistor
R3, R4	0 Ohm	2	Venkel	CR0603-16W-000T	0603 jumper
R5, R6	50 Ohm	2	Venkel	CR0603-16W-500JT	0603 size stability resistor
L4, L5	10 nH	2	Toko	LL1608 FS10NJ	0603 size stability inductor

Ordering Information

Part Number	Reel Size	Devices/Reel
SRF-2016	7"	1000
SRF-2016Z	7"	1000

NOT FOR NEW DESIGNS

Looking for pricing, stock, or lifecycle information?

Click below to explore more details on WIN SOURCE:

-  [View SRF-2016 on WIN SOURCE](#)
-  [RF Micro Devices Information](#)

Optimize Your Supply Chain with WIN SOURCE Solutions

-  Global Sourcing Solution
-  Obsolete Management
-  Cost Control Management
-  Shortage Management
-  Alternative Solution
-  Excess Inventory Management