



**THE DATASHEET OF  
SRDA3.3-4.TBT**



**PROTECTION PRODUCTS**
**Description**

RailClamp® TVS arrays are low capacitance ESD protection devices designed to protect sensitive components from overvoltage caused by electrostatic discharge (ESD), electrical fast transients (EFT), and lightning surge. It offers desirable characteristics for board level protection including fast response time, low operating and clamping voltage, and no device degradation.

The unique design incorporates surge rated, low capacitance steering diodes and a TVS diode in a single package. During transient conditions, the steering diodes direct the transient current to ground via the internal low voltage TVS. The TVS diode clamps the transient voltage to a safe level. The low capacitance array configuration allows the user to protect up to four data lines.

The SRDA3.3-4 is constructed using Semtech's proprietary EPD process technology. The EPD process provides low stand-off voltages with significant reductions in leakage current and capacitance over silicon avalanche diode processes. They feature a true operating voltage of 3.3 volts for superior protection. These devices are in a 8-pin SOIC package. It measures 3.9 x 4.9mm. The high surge capability ( $I_{pp}=25A$ ,  $t_p=8/20\mu s$ ) means it can be used in high threat environments in applications such as CO/CPE equipment, telecommunication lines, and video lines.

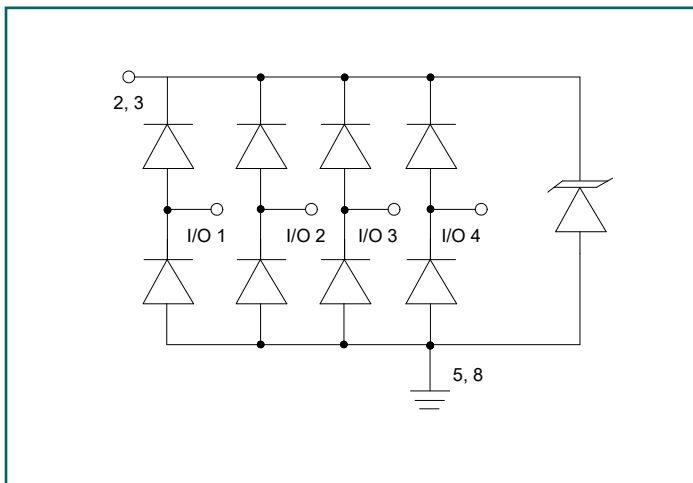
**Circuit Diagram**

**Features**

- Transient protection for high-speed data lines to
  - ♦ IEC 61000-4-2 (ESD)  $\pm 15kV$  (air),  $\pm 8kV$  (contact)
  - ♦ IEC 61000-4-4 (EFT) 40A (5/50ns)
  - ♦ IEC 61000-4-5 (Lightning) 25A (8/20 $\mu s$ )
- Array of surge rated diodes with internal TVS diode
- Protects four I/O lines
- Low capacitance (<15pF)
- Low operating voltage: 3.3V
- Low clamping voltage
- Solid-state technology

**Mechanical Characteristics**

- JEDEC SOIC-8 Package
- Pb-Free, Halogen Free, RoHS/WEEE Compliant
- Lead Finish: Matte Sn
- Marking : Marking Code
- Packaging : Tape and Reel

**Applications**

- T1/E1 secondary IC Side Protection
- T3/E3 secondary IC Side Protection
- Analog Video Protection
- Microcontroller Input Protection
- Base stations
- I<sup>2</sup>C Bus Protection

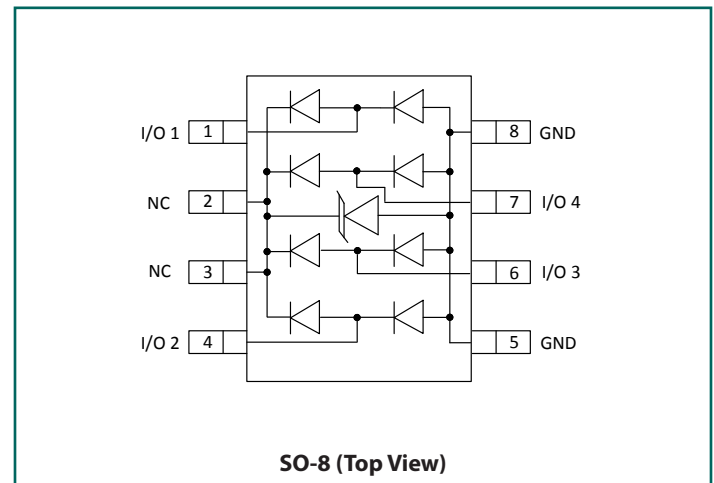
**Schematic and Pin Configuration**

## Absolute Maximum Ratings

Rating	Symbol	Value	Units
Peak Pulse Power (tp = 8/20μs)	P <sub>PK</sub>	500	W
Peak Pulse Current (tp = 8/20μs)	I <sub>PP</sub>	25	A
Lead Soldering Temperature	T <sub>L</sub>	260 (10 sec.)	°C
Operating Temperature	T <sub>OP</sub>	-40 to +85	°C
Storage Temperature	T <sub>STG</sub>	-55 to +150	°C

## Electrical Characteristics (T=25°C unless otherwise specified)

Parameter	Symbol	Conditions	Min.	Typ.	Max.	Units	
Reverse Stand-Off Voltage	V <sub>RWM</sub>				3.3	V	
Punch-Through Voltage	V <sub>PT</sub>	I <sub>PT</sub> = 2μA	3.5			V	
Snap-Back Voltage	V <sub>SB</sub>	I <sub>SB</sub> = 50mA	2.8			V	
Reverse Leakage Current	I <sub>R</sub>	V <sub>RWM</sub> = 3.3V			1	μA	
Clamping Voltage	V <sub>C</sub>	tp = 8/20μs	I <sub>PP</sub> = 1A			5.3	V
			I <sub>PP</sub> = 10A			10	
			I <sub>PP</sub> = 25A			15	
Junction Capacitance	C <sub>J</sub>	V <sub>R</sub> = 0V, f = 1MHz	I/O to GND		8	15	pF
			I/O to I/O		4		

# Typical Characteristics

Non-Repetitive Peak Pulse Power vs. Pulse Time

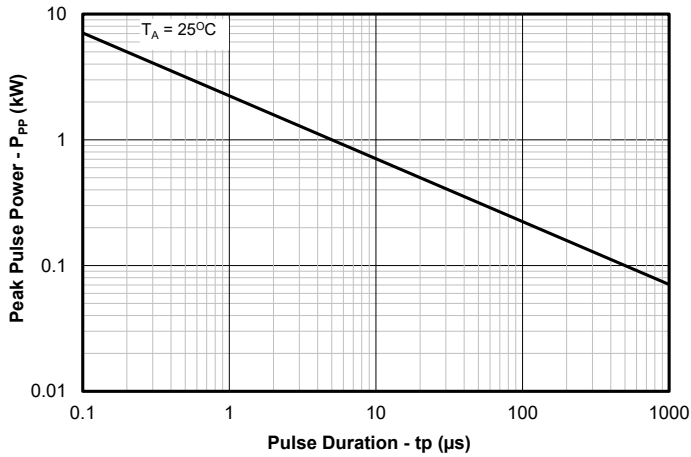

Power Derating Curve

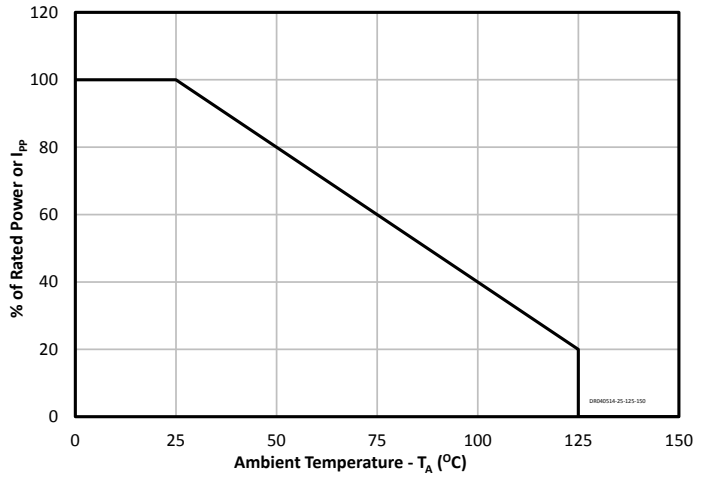

Clamping Voltage vs. Peak Pulse Current

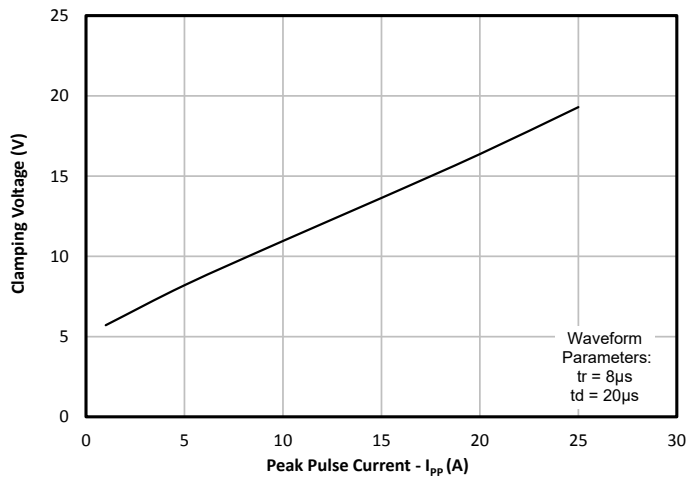

Normalized Junction Capacitance vs. Reverse Voltage

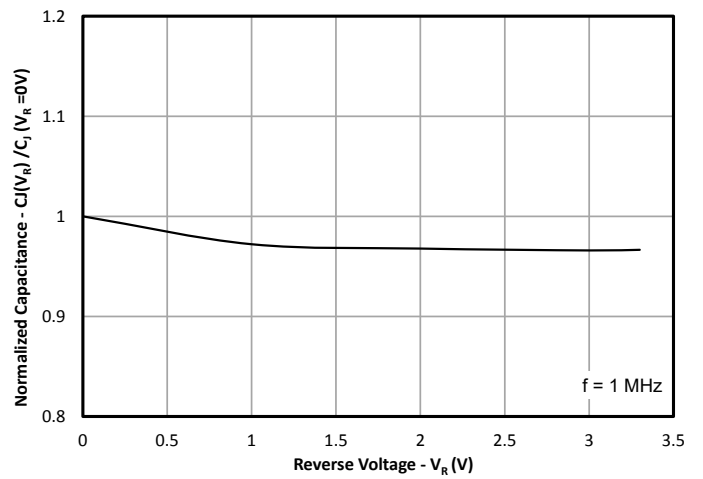

# Application Information

## Device Connection Options for Protection of Four High-Speed Data Lines

These devices are designed to protect low voltage data lines operating at 3.3 V. When the voltage on the protected line exceeds the punch-through or “turn-on” voltage of the TVS diode, the steering diodes are forward biased, conducting the transient current away from the sensitive circuitry.

Data lines are connected at pins 1, 4, 6 and 7. Pins 5 and 8 should be connected directly to a ground plane. The path length is kept as short as possible to minimize parasitic inductance.

Note that pins 2 and 3 are connected internally to the cathode of the low voltage TVS. It is not recommended that these pins be directly connected to a DC source greater than the snap-back voltage ( $V_{SB}$ ) as the device can latch on as described below.

### Data Line Protection Using Internal TVS Diode as Reference

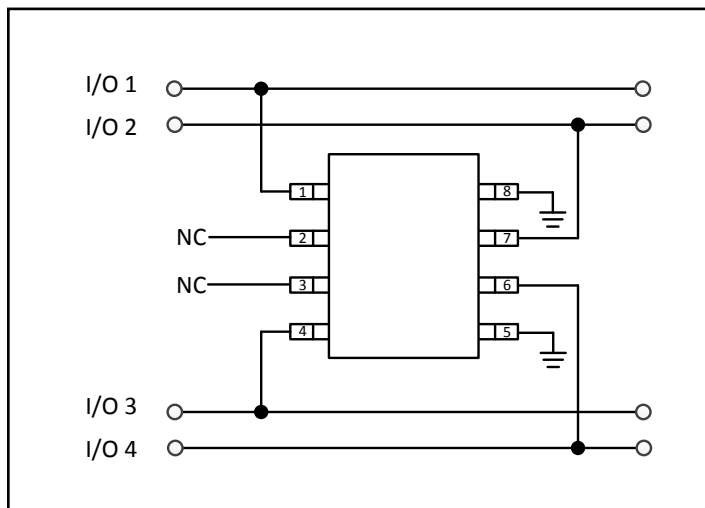

### EPD TVS IV Characteristic Curve

These devices are constructed using Semtech’s proprietary EPD technology. By utilizing the EPD technology, the SRDA3.3-4 can effectively operate at 3.3V while maintaining excellent electrical characteristics.

The EPD TVS employs a complex npnp structure in contrast to the pn structure normally found in traditional silicon-avalanche TVS diodes. Since the EPD TVS devices use a 4-layer structure, they exhibit a slightly different IV

characteristic curve when compared to conventional devices. During normal operation, the device represents a high-impedance to the circuit up to the device working voltage ( $V_{RWM}$ ). During an ESD event, the device will begin to conduct and will enter a low impedance state when the punch through voltage ( $V_{PT}$ ) is exceeded. Unlike a conventional device, the low voltage TVS will exhibit a slight negative resistance characteristic as it conducts current. This characteristic aids in lowering the clamping voltage of the device, but must be considered in applications where DC voltages are present.

When the TVS is conducting current, it will exhibit a slight “snap-back” or negative resistance characteristics due to its structure. This point is defined on the curve by the snap-back voltage ( $V_{SB}$ ) and snap-back current ( $I_{SB}$ ). To return to a non-conducting state, the current through the device must fall below the  $I_{SB}$  (approximately <50mA) and the voltage must fall below the  $V_{SB}$  (normally 2.8 V for a 3.3 V device). If a 3.3 V TVS is connected to 3.3V DC source, it will never fall below the snap-back voltage of 2.8V and will therefore stay in a conducting state.

EPD TVS IV Characteristic Curve

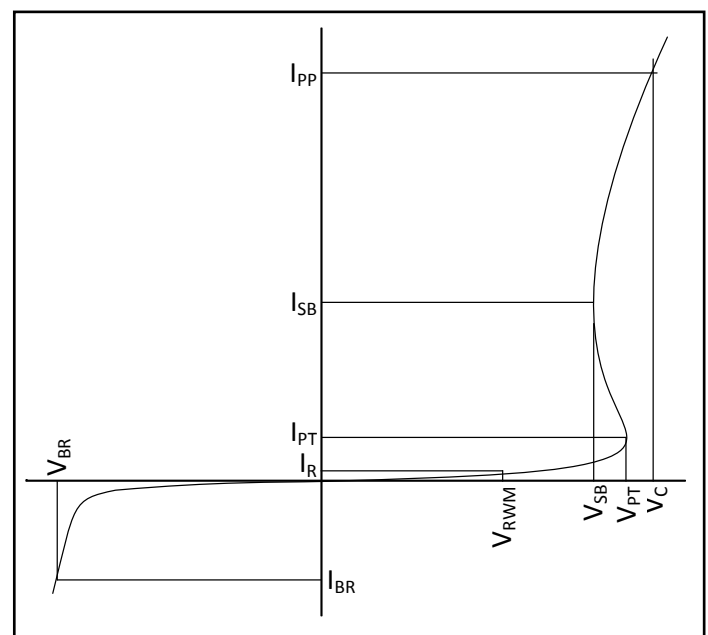

# Typical Application

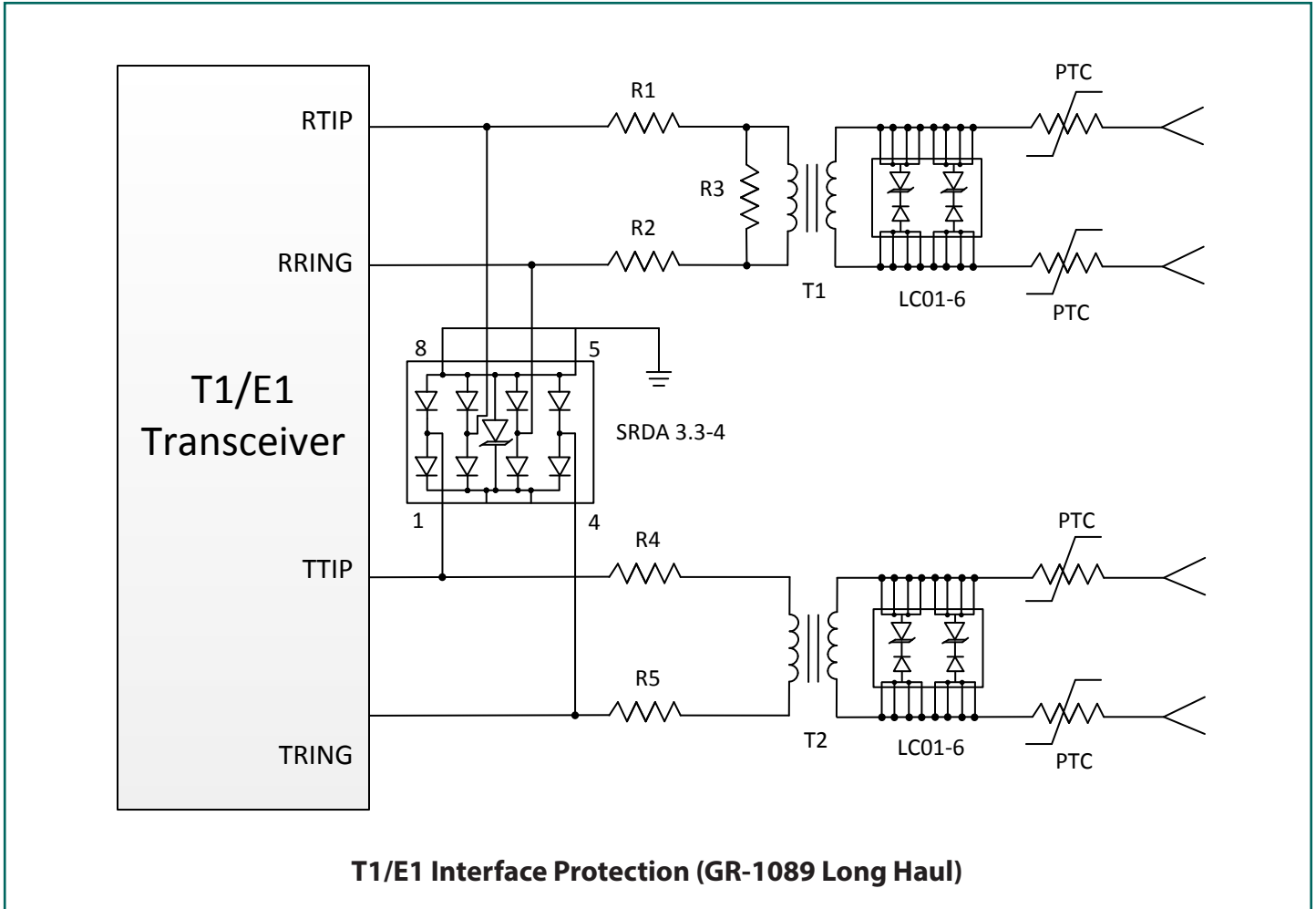

# Outline Drawing - SO-8

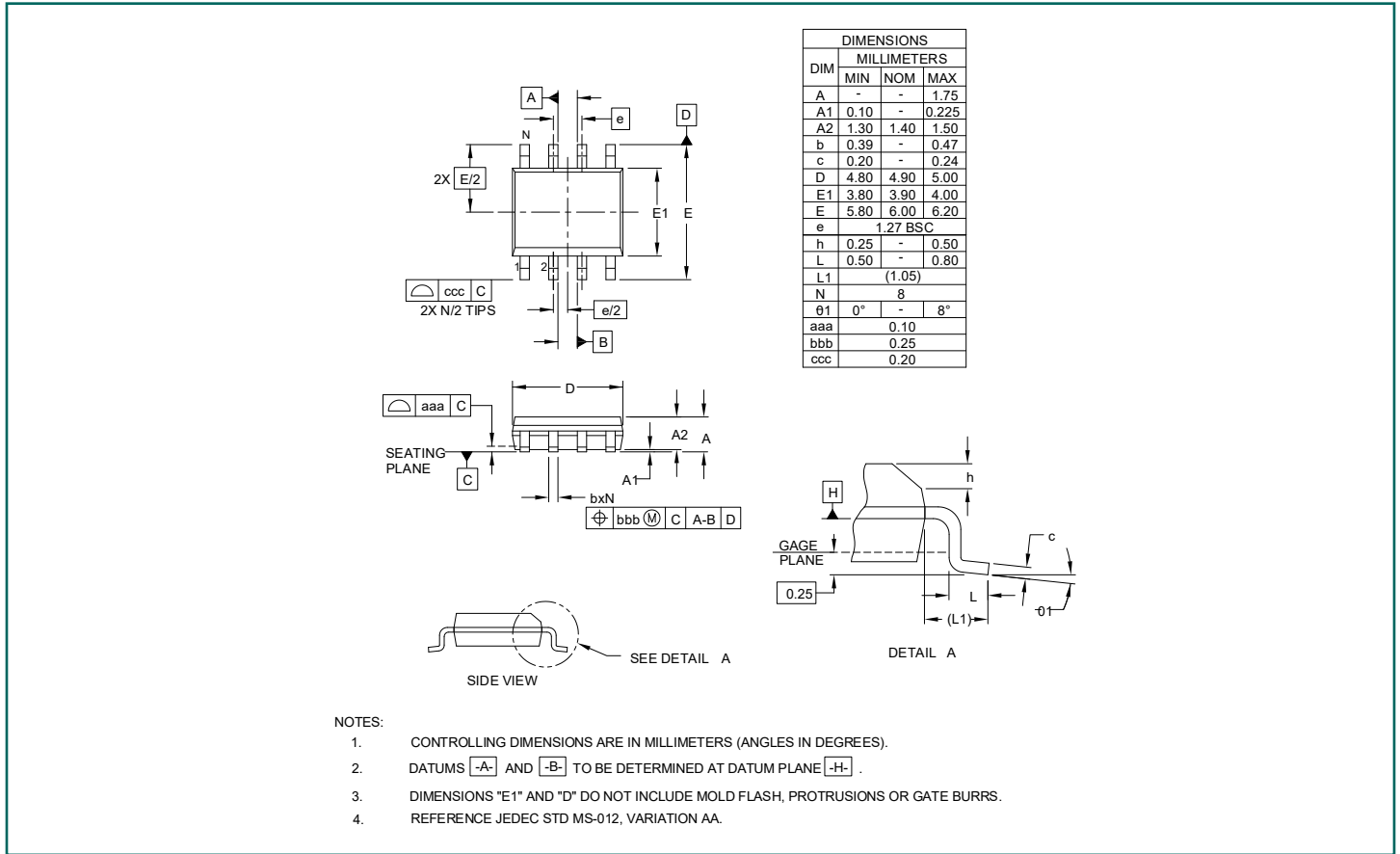

# Land Pattern - SO-8

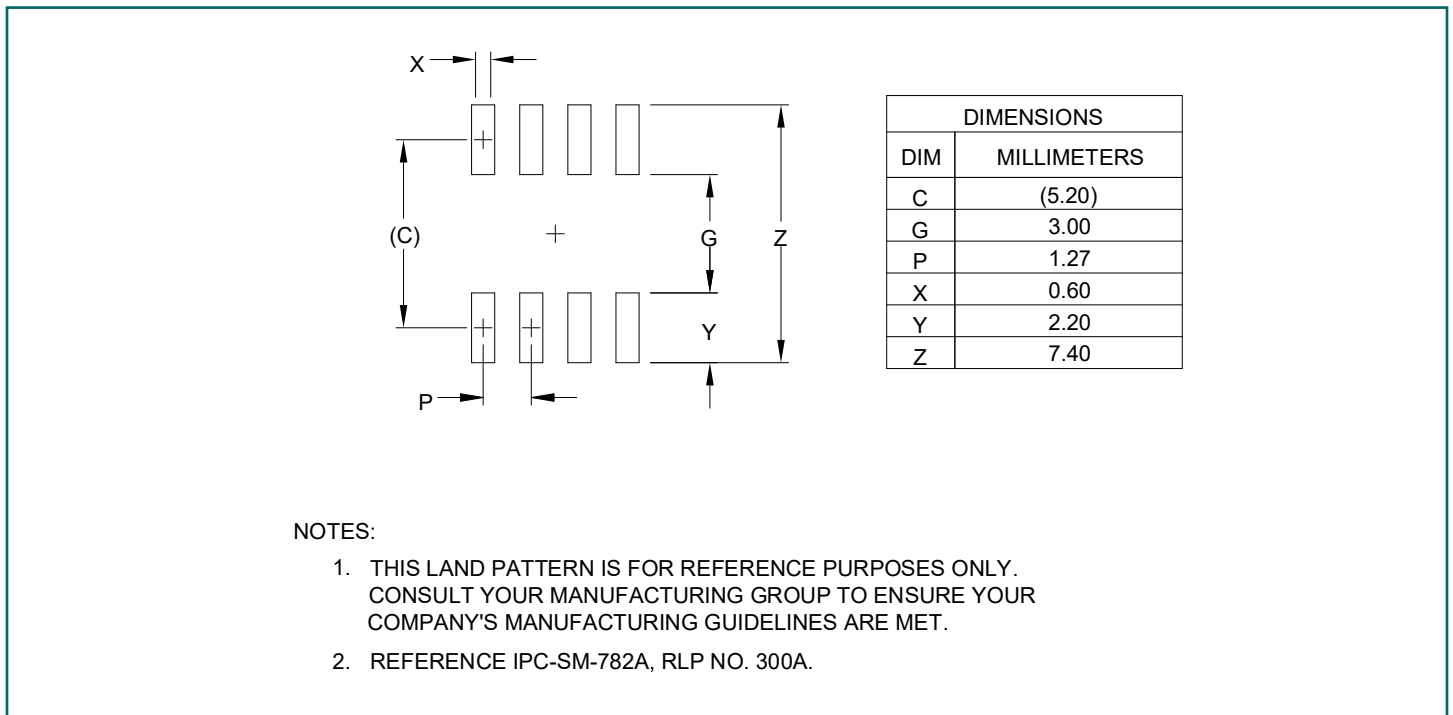

# Marking Code

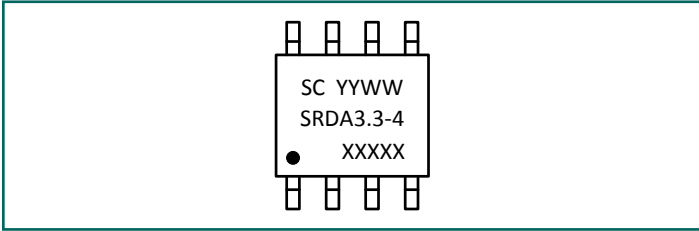

Notes:  
 YYWW = Date Code  
 XXXXX = Country of Assembly

# Tape and Reel Specification

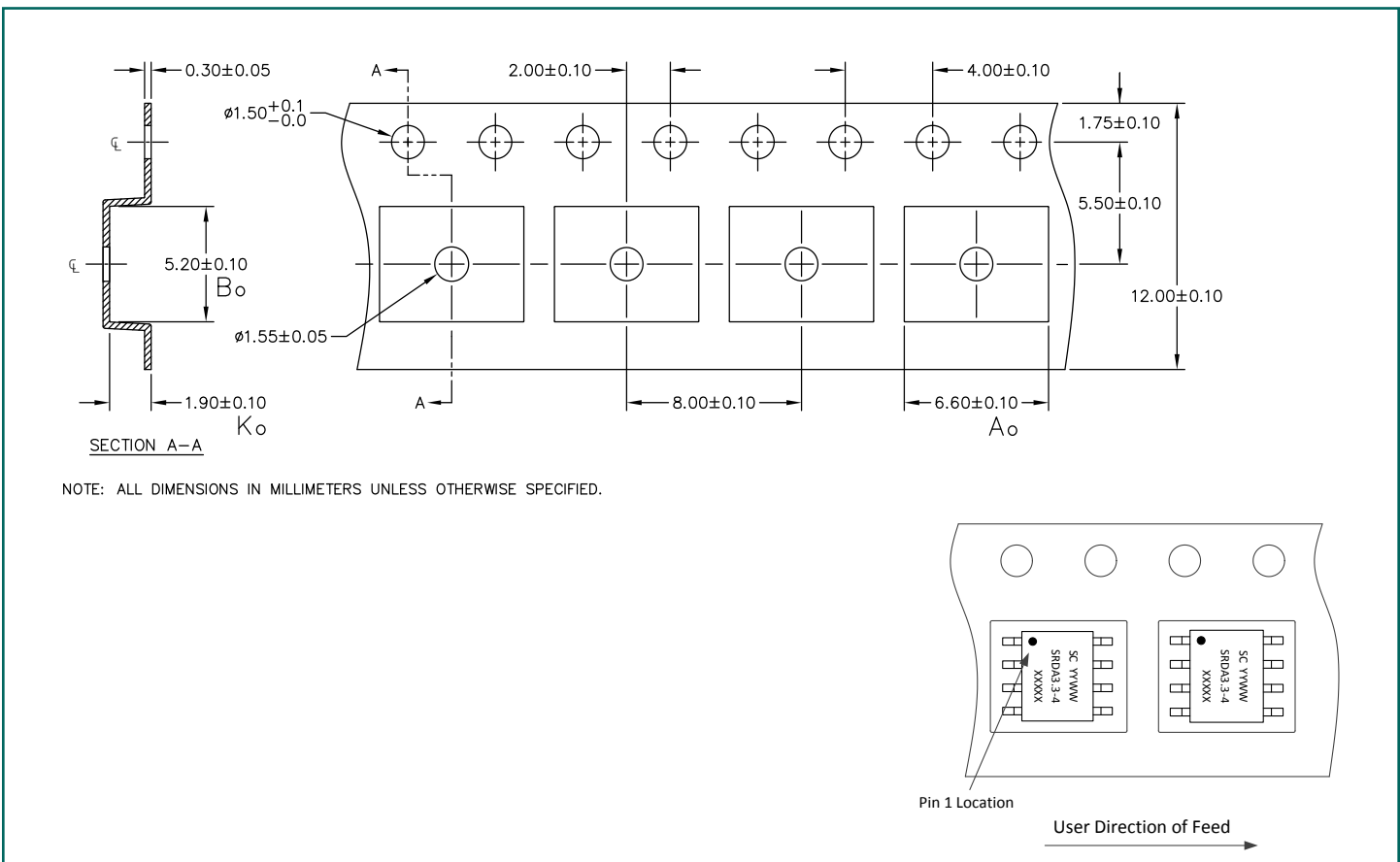

# Ordering Information

Part Number	Lead Finish	Qty per Reel	Reel Size
SRDA3.3-4.TLT	Matte Sn	3000	13 Inch



---

## Important Notice

Information relating to this product and the application or design described herein is believed to be reliable, however such information is provided as a guide only and Semtech assumes no liability for any errors in this document, or for the application or design described herein. Semtech reserves the right to make changes to the product or this document at any time without notice. Buyers should obtain the latest relevant information before placing orders and should verify that such information is current and complete. Semtech warrants performance of its products to the specifications applicable at the time of sale, and all sales are made in accordance with Semtech's standard terms and conditions of sale.

SEMTECH PRODUCTS ARE NOT DESIGNED, INTENDED, AUTHORIZED OR WARRANTED TO BE SUITABLE FOR USE IN LIFE-SUPPORT APPLICATIONS, DEVICES OR SYSTEMS, OR IN NUCLEAR APPLICATIONS IN WHICH THE FAILURE COULD BE REASONABLY EXPECTED TO RESULT IN PERSONAL INJURY, LOSS OF LIFE OR SEVERE PROPERTY OR ENVIRONMENTAL DAMAGE. INCLUSION OF SEMTECH PRODUCTS IN SUCH APPLICATIONS IS UNDERSTOOD TO BE UNDERTAKEN SOLELY AT THE CUSTOMER'S OWN RISK. Should a customer purchase or use Semtech products for any such unauthorized application, the customer shall indemnify and hold Semtech and its officers, employees, subsidiaries, affiliates, and distributors harmless against all claims, costs damages and attorney fees which could arise.

The Semtech name and logo are registered trademarks of the Semtech Corporation. All other trademarks and trade names mentioned may be marks and names of Semtech or their respective companies. Semtech reserves the right to make changes to, or discontinue any products described in this document without further notice. Semtech makes no warranty, representation or guarantee, express or implied, regarding the suitability of its products for any particular purpose. All rights reserved.

© Semtech 2017



---

## Contact Information

Semtech Corporation  
200 Flynn Road, Camarillo, CA 93012  
Phone: (805) 498-2111, Fax: (805) 498-3804  
[www.semtech.com](http://www.semtech.com)

## Looking for pricing, stock, or lifecycle information?

Click below to explore more details on WIN SOURCE:

-  [View SRDA3.3-4.TBT](#) on WIN SOURCE
-  [Semtech Corporation](#) Information

## Optimize Your Supply Chain with WIN SOURCE Solutions

-  Global Sourcing Solution
-  Obsolete Management
-  Cost Control Management
-  Shortage Management
-  Alternative Solution
-  Excess Inventory Management