



# THE DATASHEET OF SPF7211



# 2-ph Stepper-motor Driver ICs SPF7211

## Features

- Low output saturation voltage (high-side: 1.5V max.; low-side: 0.8V max.)
- Built-in recovery diode
- Built-in standby function
- Built-in overcurrent and thermal protection circuits and low voltage input shutoff function
- Built-in overload and disconnection detection function

## Absolute Maximum Ratings

Parameter	Symbol	Ratings	Unit	Remarks
Main power supply voltage	V <sub>BB</sub>	40	V	
Input voltage	V <sub>IN</sub>	-0.3 to 15	V	V <sub>IN</sub> ≤ V <sub>BB</sub>
Output current	I <sub>o</sub>	±0.8	A	
	I <sub>oPeak</sub>	±1.0	A	T <sub>w</sub> < 1mS
Flag terminal withstand voltage	V <sub>Flag</sub>	7	V	V <sub>Flag</sub> ≤ V <sub>BB</sub>
Flag terminal current	I <sub>Flag</sub>	3	mA	
Detect voltage	V <sub>Rs</sub>	-2 to 2	V	
Power dissipation	P <sub>D</sub>	4.1	W	For Ta = 25°C *1
		39	W	For Tc (Ttab) = 25°C
Junction temperature	T <sub>J</sub>	150	°C	
Operating temperature	Top	-40 to 110	°C	
Storage temperature	T <sub>stg</sub>	-40 to 150	°C	

Note: \*1: With glass epoxy + copper foil board (size 5.0\*7.4cm; t: glass epoxy = 1.6mm/copper foil = 18μm)

## Recommended Operation Range

Parameter	Symbol	Ratings	Unit	Remarks
Main power supply voltage	V <sub>BB</sub>	6 to 18	V	
Input voltage	V <sub>IN</sub>	-0.3 to 7.0	V	V <sub>IN</sub> ≤ V <sub>BB</sub>
Output current	I <sub>o</sub>	±0.5	A	Continuous
Flag terminal withstand voltage	V <sub>Flag</sub>	0 to 7.0	V	V <sub>Flag</sub> ≤ V <sub>BB</sub>
Flag terminal current	I <sub>Flag</sub>	0 to 1.0	mA	
Detect voltage	V <sub>Rs</sub>	-1 to 1	V	
Operating temperature	Top	-40 to 110	°C	

## Electrical Characteristics

Parameter	Symbol	Ratings			Unit	Conditions	
		min	typ	max			
Main power supply current	I <sub>BB</sub>			50	mA	In ordinary operation (no load)	
	I <sub>BBs</sub>			50	μA	At sleep	
Low voltage protection operation voltage	V <sub>VULO</sub>	3.5		4.5	V		
UVLO hysteresis voltage	V <sub>VULOys</sub>		0.5		V		
	I <sub>leakL</sub>			100	μA	V <sub>BB</sub> = 40V, V <sub>o</sub> = 0V	
Output leak current	I <sub>leakH</sub>	-100			μA	V <sub>BB</sub> = V <sub>o</sub> = 40V	
	V <sub>satL</sub>			0.5	V	I <sub>o</sub> = 0.5A	
Output saturation voltage				0.8	V	I <sub>o</sub> = 0.8A	
				1.2	V	I <sub>o</sub> = -0.5A	
				1.5	V	I <sub>o</sub> = -0.8A	
Recovery diode forward voltage	V <sub>F-L</sub>			1.2	V	I <sub>o</sub> = 0.5A	
	V <sub>F-H</sub>			1.3	V	I <sub>o</sub> = -0.5A	
	V <sub>F-GO</sub>	1.2			V	I <sub>o</sub> = -0.5A	
Input terminal	Input voltage			0.8	V		
	Hysteresis voltage	V <sub>thys</sub>	2.0		V		
Ph terminal	Input current	I <sub>IL</sub>	-5	5	μA		
		I <sub>IH</sub>	-5	5	μA		
Ixx, Set terminals	Input current	I <sub>IL</sub>	-30		μA		
		I <sub>IH</sub>		50	μA	V <sub>IL</sub> = 0.8V	
Detect voltage			660	700	mV	V <sub>IH</sub> = 2.0V	
			420	450	480	mV	I <sub>x0</sub> = Low, I <sub>x1</sub> = High
			40	70	90	mV	I <sub>x0</sub> = High, I <sub>x1</sub> = Low
Oscillation frequency	F <sub>osc</sub>	28.8	48	72	kHz		
PWM frequency	F <sub>FWM</sub>	14.4	24	36	kHz	Ct = 2200pF ± 20%	
Ct terminal threshold voltage	V <sub>ctL</sub>		0.5		V		
	V <sub>ctH</sub>		1.5		V		
Ct terminal current	I <sub>ctsink</sub>		720		μA	*1	
	I <sub>ctsource</sub>		-120		μA		
Overcurrent detection voltage	V <sub>ocpL</sub>	1.5	3.0	4.2	V	Out voltage	
	V <sub>ocpH</sub>	V <sub>BB</sub> -2.5	V <sub>BB</sub> -2.0	V <sub>BB</sub> -1.7	V	Out voltage	
	V <sub>ocpL</sub>	1.0		1.85	V	V <sub>BB</sub> = 5.5V	
	V <sub>ocpH</sub>	V <sub>BB</sub> -2.3		V <sub>BB</sub> -1.5	V	V <sub>BB</sub> = 5.5V	
Open detection voltage	V <sub>open</sub>		-60		mV	Sence voltage	
Flag terminal leak current	I <sub>leakFlag</sub>			10	μA	V <sub>Flag</sub> = 7V	
Flag terminal saturation voltage	V <sub>FlagL</sub>			0.5	V	I <sub>Flag</sub> = 1mA	
Flag terminal current	I <sub>Flag</sub>			3	mA		
Set terminal	Response pulse width	T <sub>pw</sub>	10		μS	In ordinary operation	
		T <sub>pws</sub>	100		μS	At sleep	
	Pulse rate	F <sub>clock</sub>	17	24	31	Hz	Ct = 2200pF
Flag response time	Pulse number	Pulse		256			
	OCP operation	t <sub>ocp1</sub>	2.5	5.0	10.0	μS	In ordinary operation; Ct = 2200pF
		t <sub>ocp2</sub>	5.0	10.0	20.0	μS	At switching the phase
t <sub>ocp3</sub>		5.0	10.0	20.0	μS	When I <sub>xx</sub> shifts from L to H	
Open operation	t <sub>open1</sub>	2.5	5.0	10.0	μS	In ordinary operation	
	t <sub>open2</sub>	2.5	5.0	10.0	μS	When I <sub>xx</sub> shifts from L to H	
	t <sub>onH1</sub>		1.5		μS		
I/O propagation time	t <sub>offH1</sub>		1.5		μS		
	t <sub>onH2</sub>		100		μS		
	t <sub>offH2</sub>		100		μS		
	t <sub>onL1</sub>		2.0		μS		
	t <sub>offL1</sub>		0.5		μS		
	t <sub>onL2</sub>		100		μS		
	t <sub>offL2</sub>		100		μS		
	T <sub>J</sub>		150		°C		
	Thermal protection hysteresis	ΔT <sub>J</sub>		20		°C	*2
	Thermal alarm temperature	T <sub>alarm</sub>	120	130	140	°C	
Thermal alarm hysteresis	ΔT <sub>alarm</sub>		20		°C		

Note:

- \*1: The Ct terminal threshold voltage and current are the design values. Warranty is based on the oscillation frequency.  
\*2: Thermal protection and alarm temperatures are design values.

## External Dimensions (unit: mm)

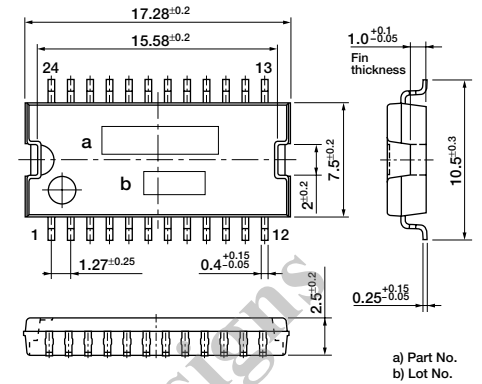

## Standard Circuit Diagram

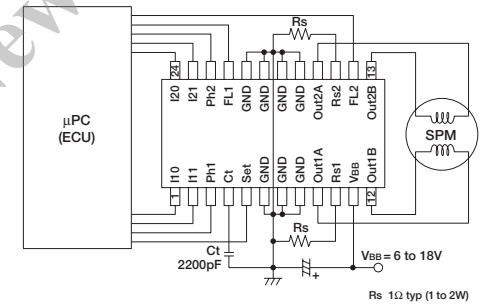

## Excitation Signal Time Chart

2-phase excitation

Clock	0	1	2	3	0	1
Ph1	L	H	H	L	L	H
I10, I11	H	H	H	H	H	H
Ph2	L	L	L	H	L	L
I20, I21	L	H	H	H	H	H

1 to 2-phase excitation

Clock	0	1	2	3	4	5	6	7	0	1	2	3
Ph1	L	H	H	H	H	L	L	L	L	H	H	H
I10, I11	H	L	H	H	H	H	H	H	H	H	L	H
Ph2	L	L	L	H	H	H	H	L	L	L	L	L
I20, I21	H	H	H	L	H	H	H	L	H	H	H	L

\* For the 1 to 2-phase excitation application, switch the Ph signal in the step of 1-ph excitation (I<sub>xx</sub> turns from high to low).  
The OPEN detection function is invalid except in this sequence.

Electrical Characteristics

■ Vsat Temperature Characteristics (Io=0.5A)

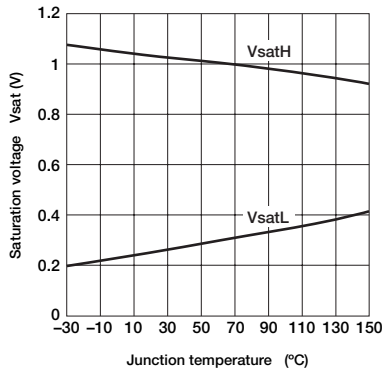

■ Diode Vf Characteristics (If=0.5A)

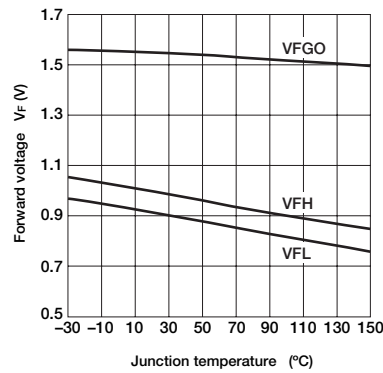

■ OSC Temperature Characteristics

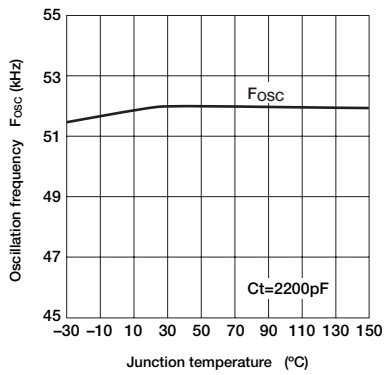

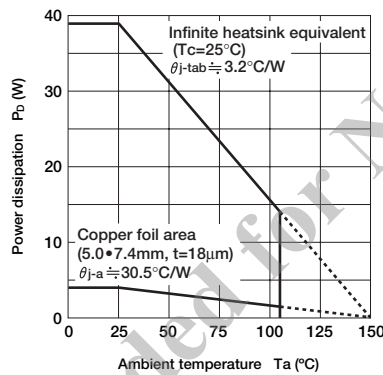

■ Ta-Pd Characteristics









Not Recommended for New Designs

## Looking for pricing, stock, or lifecycle information?

Click below to explore more details on WIN SOURCE:

-  [View SPF7211 on WIN SOURCE](#)
-  [Sanken Information](#)

## Optimize Your Supply Chain with WIN SOURCE Solutions

-  Global Sourcing Solution
-  Obsolete Management
-  Cost Control Management
-  Shortage Management
-  Alternative Solution
-  Excess Inventory Management