

SP720 Series 3pF 4kV Diode Array

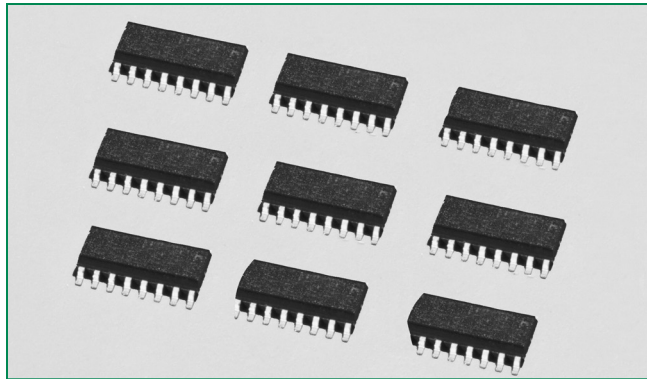

Pinout

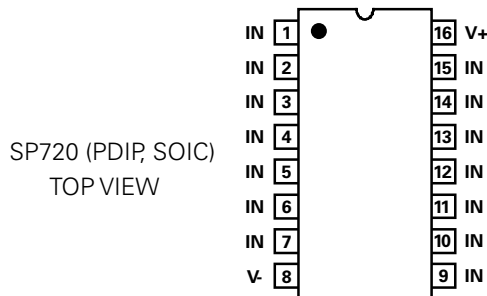

Functional Block Diagram

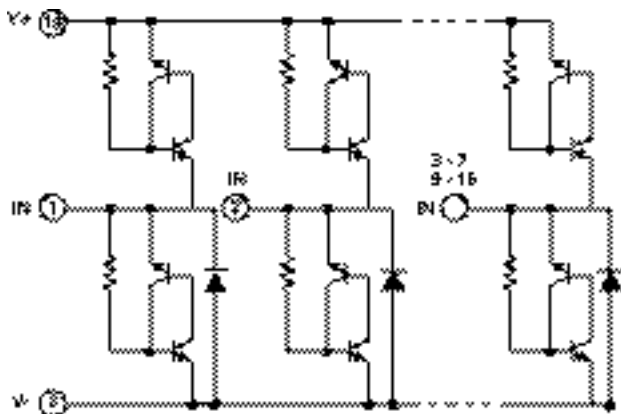

Additional Information



Life Support Note:

Not Intended for Use in Life Support or Life Saving Applications

The products shown herein are not designed for use in life sustaining or life saving applications unless otherwise expressly indicated.

Description

The SP720 is an array of SCR/Diode bipolar structures for ESD and over-voltage protection to sensitive input circuits. The SP720 has 2 protection SCR/Diode device structures per input. A total of 14 available inputs can be used to protect up to 14 external signal or bus lines. Over-voltage protection is from the IN (pins 1-7 and 9-15) to V+ or V-.

The SCR structures are designed for fast triggering at a threshold of one $+V_{BE}$ diode threshold above V+ (Pin 16) or a $-V_{BE}$ diode threshold below V- (Pin 8). From an IN input, a clamp to V+ is activated if a transient pulse causes the input to be increased to a voltage level greater than one V_{BE} above V+. A similar clamp to V- is activated if a negative pulse, one V_{BE} less than V-, is applied to an IN input. Standard ESD Human Body Model (HBM) Capability is:

Features

- ESD Interface Capability for HBM Standards
 - MIL STD 3015.7 15kV
 - IEC 61000-4-2, Direct Discharge,
 - Single Input 4kV (Level 2)
 - Two Inputs in Parallel 8kV (Level 4)
 - IEC 61000-4-2, Air Discharge 15kV (Level 4)
- High Peak Current Capability
 - IEC 61000-4-5 (8/20 μ s) \pm 3A
 - Single Pulse, 100 μ s Pulse Width \pm 2A
 - Single Pulse, 4 μ s Pulse Width \pm 5A
- Designed to Provide Over-Voltage Protection
 - Single-Ended Voltage Range to +30V
 - Differential Voltage Range to \pm 15V
- Fast Switching 2ns Risetime
- Low Input Leakages 1nA at 25° (Typ)
- Low Input Capacitance 3pF (Typ)
- An Array of 14 SCR/Diode Pairs
- Operating Temperature Range -40°C to 105°C

Applications

- Microprocessor/Logic Input Protection
- Analog Device Input Protection
- Data Bus Protection
- Voltage Clamp

Absolute Maximum Ratings

Parameter	Rating	Units
Continuous Supply Voltage, (V+) - (V-)	+35	V
Forward Peak Current, I_{IN} to V_{CC} , I_{IN} to GND (Refer to Figure 5)	$\pm 2, 100\mu s$	A

CAUTION: Stresses above those listed in "Absolute Maximum Ratings" may cause permanent damage to the device. This is a stress only rating and operation of the device at these or any other conditions above those indicated in the operational sections of this specification is not implied.

Note:
ESD Ratings and Capability - See Figure 1, Table 1
Load Dump and Reverse Battery (Note 2)

Thermal Information

Parameter	Rating	Units
Thermal Resistance (Typical, Note 1)	θ_{JA}	$^{\circ}C/W$
PDIP Package	90	$^{\circ}C/W$
SOIC Package	130	$^{\circ}C/W$
Maximum Storage Temperature Range	-65 to 150	$^{\circ}C$
Maximum Junction Temperature (Plastic Package)	150	$^{\circ}C$
Maximum Lead Temperature (Soldering 20-40s) (SOIC Lead Tips Only)	260	$^{\circ}C$

1. θ_{JA} is measured with the component mounted on an evaluation PC board in free air.

Electrical Characteristics $T_A = -40^{\circ}C$ to $105^{\circ}C$, $V_{IN} = 0.5V_{CC}$, Unless Otherwise Specified

Parameter	Symbol	Test Conditions	Min	Typ	Max	Units
Operating Voltage Range, $V_{SUPPLY} = [(V+) - (V-)]$	V_{SUPPLY}		-	2 to 30	-	V
Forward Voltage Drop:		$I_{IN} = 1A$ (Peak Pulse)				
IN to V-	V_{FWDL}		-	2	-	V
IN to V+	V_{FWDH}		-	2	-	V
Input Leakage Current	I_{IN}		-20	5	20	nA
Quiescent Supply Current	$I_{QUIESCENT}$		-	50	200	nA
Equivalent SCR ON Threshold		Note 3	-	1.1	-	V
Equivalent SCR ON Resistance		V_{FWD}/I_{FWD} ; Note 3	-	1	-	Ω
Input Capacitance	C_{IN}		-	3	-	pF
Input Switching Speed	t_{ON}		-	2	-	ns

- Notes:
- In automotive and battery operated systems, the power supply lines should be externally protected for load dump and reverse battery. V+ and V- pins are connected to the same supply voltage source as the device or control line under protection, a current limiting resistor should be connected in series between the external supply and the SP720 supply pins to limit reverse battery current to within the rated maximum limits. Bypass capacitors of typically 0.01 μF or larger from the V+ and V- pins to ground are recommended.
 - Refer to the Figure 3 graph for definitions of equivalent "SCR ON Threshold" and "SCR ON Resistance." These characteristics are given here for thumb-rule information to determine peak current and dissipation under EOS conditions.

Typical Application of the SP720

(Application as an Input Clamp for Over-voltage, greater than $1V_{BE}$ Above V+ or less than $-1V_{BE}$ below V-)

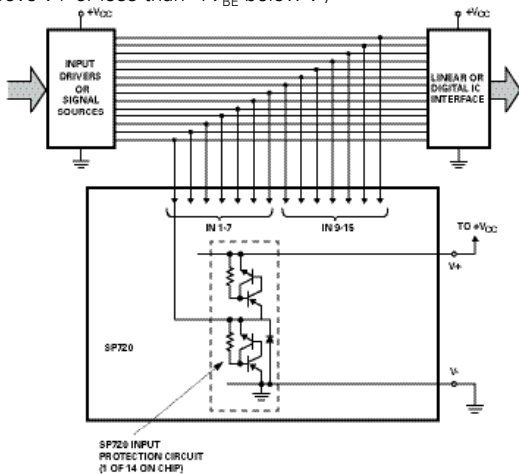

ESD Capability

ESD capability is dependent on the application and defined test standard. The evaluation results for various test standards and methods based on Figure 1 are shown in Table 1.

For the “Modified” MIL-STD-3015.7 condition that is defined as an “in-circuit” method of ESD testing, the V+ and V- pins have a return path to ground and the SP720 ESD capability is typically greater than 15kV from 100pF through 1.5kΩ. By strict definition of MIL-STD-3015.7 using “pin-to-pin” device testing, the ESD voltage capability is greater than 6kV. The MIL-STD-3015.7 results were determined from AT&T ESD Test Lab measurements.

The HBM capability to the IEC 61000-4-2 standard is greater than 15kV for air discharge (Level 4) and greater than 4kV for direct discharge (Level 2). Dual pin capability (2 adjacent pins in parallel) is well in excess of 8kV (Level 4).

For ESD testing of the SP720 to EIAJ IC121 Machine Model (MM) standard, the results are typically better than 1kV from 200pF with no series resistance.

Figure 1: Electrostatic Discharge Test

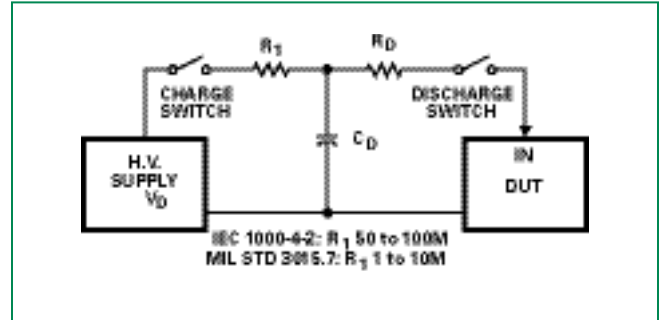

Table 1: ESD Test Conditions

Standard	Type/Mode	R _D	C _D	±V _D
MIL STD 3015.7	Modified HBM	1.5kΩ	100pF	15kV
	Standard HBM	1.5kΩ	100pF	6kV
IEC 61000-4-2	HBM, Air Discharge	330Ω	150pF	15kV
	HBM, Direct Discharge	330Ω	150pF	4kV
	HBM, Direct Discharge, Two Parallel Input Pins	330Ω	150pF	8kV
EIAJ IC121	Machine Model	0kΩ	200pF	1kV

Figure 2: Low Current SCR Forward Voltage Drop Curve

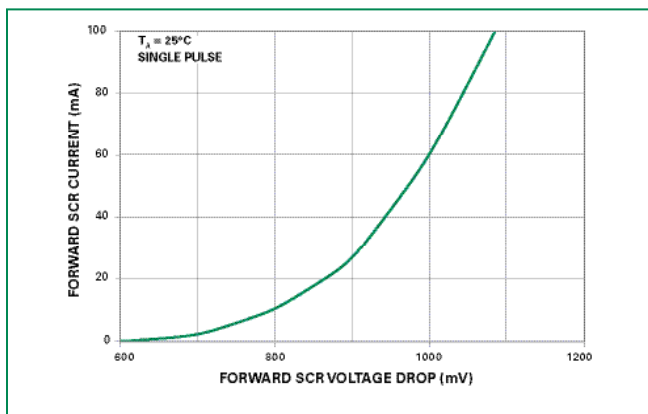
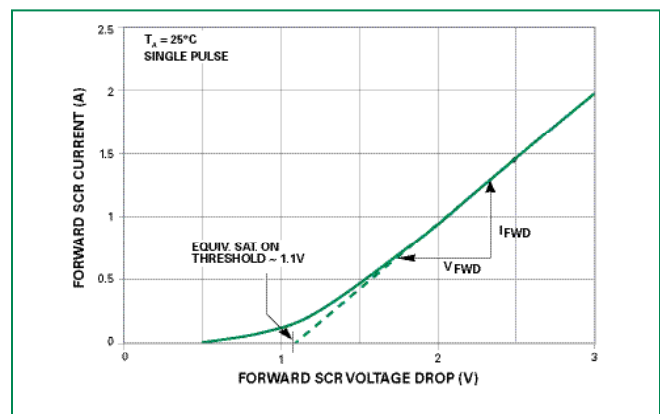

Figure 3: High Current SCR Forward Voltage Drop Curve



Peak Transient Current Capability for Long Duration Surges

The peak transient current capability rises sharply as the width of the current pulse narrows. Destructive testing was done to fully evaluate the SP720's ability to withstand a wide range of transient current pulses. The circuit used to generate current pulses is shown in Figure 4.

The test circuit of Figure 4 is shown with a positive pulse input. For a negative pulse input, the (-) current pulse input goes to an SP720 'IN' input pin and the (+) current pulse input goes to the SP720 V- pin. The V+ to V- supply of the SP720 must be allowed to float. (i.e., It is not tied to the ground reference of the current pulse generator.) Figure 5 shows the point of overstress as defined by increased leakage in excess of the data sheet published limits.

The maximum peak input current capability is dependent on the V+ to V- voltage supply level, improving as the supply voltage is reduced. Values of 0, 5, 15 and 30 voltages are shown. The safe operating range of the transient peak current should be limited to no more than 75% of the measured overstress level for any given pulse width as shown in Figure 5.

When adjacent input pins are paralleled, the sustained peak current capability is increased to nearly twice that of a single pin. For comparison, tests were run using dual pin combinations 1+2, 3+4, 5+6, 7+9, 10+11, 12+13 and 14+15.

The overstress curve is shown in Figure 5 for a 15V supply condition. The dual pins are capable of 10A peak current for a 10µs pulse and 4A peak current for a 1ms pulse. The complete for single pulse peak current vs. pulse width time ranging up to 1 second are shown in Figure 5.

Figure 4: Typical SP720 Peak Current Test Circuit with a Variable Pulse Width Input

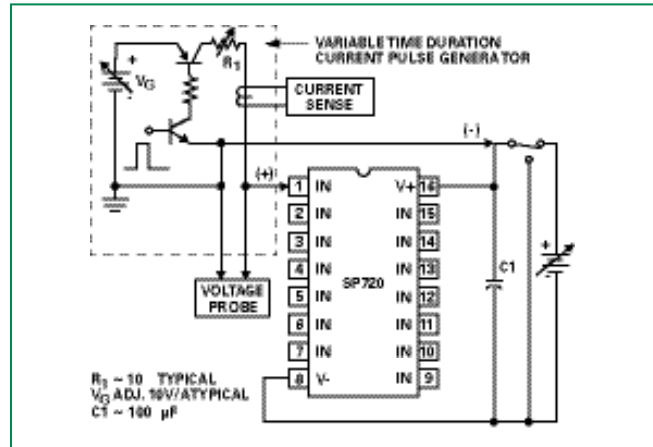
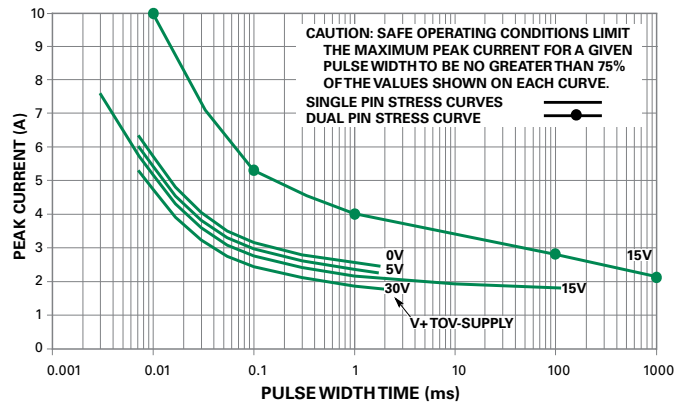

Figure 5: SP720 Typical Nonrepetitive Peak Current Pulse Capability

Showing the Measured Point of Overstress in Amperes vs pulse width time in milliseconds ($T_A = 25^\circ C$)



Soldering Parameters

Reflow Condition		Pb – Free assembly
Pre Heat	- Temperature Min ($T_{s(min)}$)	150°C
	- Temperature Max ($T_{s(max)}$)	200°C
	- Time (min to max) (t_s)	60 – 180 secs
Average ramp up rate (Liquidus) Temp (T_L) to peak		5°C/second max
$T_{s(max)}$ to T_L - Ramp-up Rate		5°C/second max
Reflow	- Temperature (T_L) (Liquidus)	217°C
	- Temperature (t_l)	60 – 150 seconds
Peak Temperature (T_p)		260 ^{+0/-5} °C
Time within 5°C of actual peak Temperature (t_p)		20 – 40 seconds
Ramp-down Rate		5°C/second max
Time 25°C to peak Temperature (T_p)		8 minutes Max.
Do not exceed		260°C

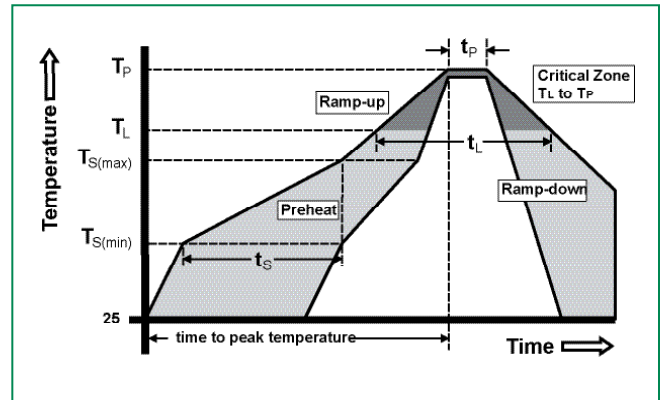

Package Dimensions Dual-In-Line Plastic Packages (PDIP)

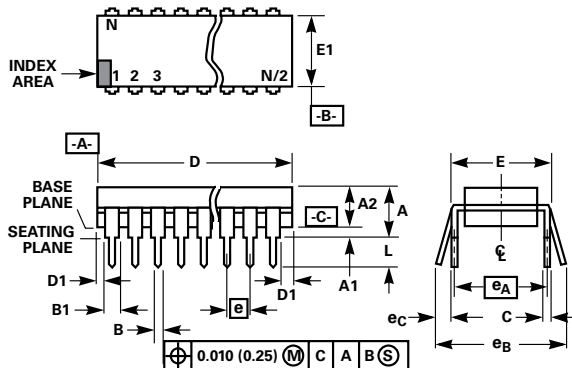

Notes:

- Controlling Dimensions: INCH. in case of conflict between English and Metric dimensions, the inch dimensions control.
- Dimensioning and tolerancing per ANSI Y14.5M-1982.
- Symbols are defined in the "MO Series Symbol List" in Section 2.2 of Publication No. 95.
- Dimensions A, A1 and L are measured with the package seated in JEDEC seating plane gauge GS-3.
- D, D1, and E1 dimensions do not include mold flash or protrusions. Mold flash or protrusions shall not exceed 0.010 inch (0.25mm).
- E and e_A are measured with the leads constrained to be perpendicular to datum $-C-$.
- e_B and e_C are measured at the lead tips with the leads unconstrained. e_C must be zero or greater.
- B1 maximum dimensions do not include dambar protrusions. Dambar protrusions shall not exceed 0.010 inch (0.25mm).
- N is the maximum number of terminal positions.
- Corner leads (1, N, N/2 and N/2 + 1) for E8.3, E16.3, E18.3, E28.3, E42.6 will have a B1 dimension of 0.030 - 0.045 inch (0.76 - 1.14mm).

Package	PDIP				Notes
Pins	16 Lead Dual-in-Line				
JEDEC	MS-001				
	Millimeters		Inches		
	Min	Max	Min	Max	
A	-	5.33	-	0.210	4
A1	0.39	-	0.015	-	4
A2	2.93	4.95	0.115	0.195	-
B	0.356	0.558	0.014	0.022	-
B1	1.15	1.77	0.045	0.070	8, 10
C	0.204	0.355	0.008	0.014	-
D	18.66	19.68	0.735	0.775	5
D1	0.13	-	0.005	-	5
E	7.62	8.25	0.300	0.325	6
E1	6.10	7.11	0.240	0.280	5
e	2.54 BSC		0.100 BSC		-
e_A	7.62 BSC		0.300 BSC		6
e_B	-	10.92	-	0.430	7
L	2.93	3.81	0.115	0.150	4
N	16		16		9

Package Dimensions — Small Outline Plastic Packages (SOIC)

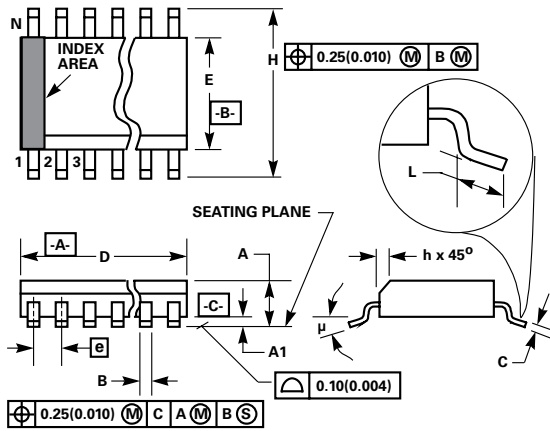

- Notes:
- Symbols are defined in the "MO Series Symbol List" in Section 2.2 of Publication Number 95.
 - Dimensioning and tolerancing per ANSI Y14.5M-1982.
 - Dimension "D" does not include mold flash, protrusions or gate burrs. Mold flash, protrusion and gate burrs shall not exceed 0.15mm (0.006 inch) per side.
 - Dimension "E" does not include interlead flash or protrusions. Interlead flash and protrusions shall not exceed 0.25mm (0.010 inch) per side.
 - The chamfer on the body is optional. If it is not present, a visual index feature must be located within the crosshatched area.
 - "L" is the length of terminal for soldering to a substrate.
 - "N" is the number of terminal positions.
 - Terminal numbers are shown for reference only.
 - The lead width "B" as measured 0.36mm (0.014 inch) or greater above the seating plane, shall not exceed a maximum value of 0.61mm (0.024 inch).
 - Controlling dimension:MILLIMETER. Converted inch dimensions are not necessarily exact.

Package	SOIC				
Pins	16				
JEDEC	MS-012				
	Millimeters		Inches		Notes
	Min	Max	Min	Max	
A	1.35	1.75	0.0532	0.0688	-
A1	0.10	0.25	0.0040	0.0098	-
B	0.33	0.51	0.013	0.020	9
C	0.19	0.25	0.0075	0.0098	-
D	9.80	10.00	0.3859	0.3937	3
E	3.80	4.00	0.1497	0.1574	4
e	1.27 BSC		0.050 BSC		-
H	5.80	6.20	0.2284	0.2440	-
h	0.25	0.50	0.0099	0.0196	5
L	0.40	1.27	0.016	0.050	6
N	16		16		7
μ	0°	8°	0°	8°	-

Product Characteristics

Lead Plating	Matte Tin
Lead Material	Copper Alloy
Lead Coplanarity	0.004 inches (0.102mm)
Substitute Material	Silicon
Body Material	Molded Epoxy
Flammability	UL 94 V-0

Part Numbering System

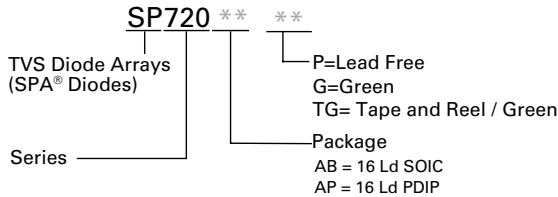

See Ordering Information section for specific options available

Ordering Information

Part Number	Temp. Range (°C)	Package	Environmental Informaton	Marking	Min. Order
SP720APP	-40 to 105	16 Ld PDIP	Lead-free	SP720AP(P) ¹	1500
SP720ABG	-40 to 105	16 Ld SOIC	Green	SP720A(B)G ²	1920
SP720ABTG	-40 to 105	16 Ld SOIC Tape and Reel	Green	SP720A(B)G ²	2500

- Notes:
- SP720AP(P) means device marking either SP720AP or SP720APP.
 - SP720A(B)G means device marking either SP720AG or SP720ABG which are good for types SP720ABG and SP720ABTG.

Disclaimer Notice - Information furnished is believed to be accurate and reliable. However, users should independently evaluate the suitability of and test each product selected for their own applications. Littelfuse products are not designed for, and may not be used in, all applications. Read complete Disclaimer Notice at www.littelfuse.com/disclaimer-electronics.

Looking for pricing, stock, or lifecycle information?

Click below to explore more details on WIN SOURCE:

 [View SP720ABG on WIN SOURCE](#)

 [Littelfuse Inc. Information](#)

Optimize Your Supply Chain with WIN SOURCE Solutions

-  Global Sourcing Solution
-  Obsolete Management
-  Cost Control Management
-  Shortage Management
-  Alternative Solution
-  Excess Inventory Management