



**THE DATASHEET OF  
SP3243EEA-L**





## General Description

The SP3243E products (SP3243E, SP3243EB, SP3243EH, and SP3243EU) are 3 driver / 5 receiver RS-232 transceiver solutions intended for portable or hand-held applications such as notebook and palmtop computers. The SP3243E includes one complementary receiver that remains alert to monitor an external device's Ring Indicate signal while the device is shutdown. The SP3243E and EB devices feature slew-rate limited outputs for reduced crosstalk and EMI. The "EU" and "EH" series are optimized for high speed with data rates up to 1Mbps, easily meeting the demands of high speed RS-232 applications. The SP3243E series uses an internal high-efficiency charge-pump power supply that requires only 0.1 $\mu$ F capacitors in 3.3V operation. This charge pump and MaxLinear's driver architecture allow the SP3243E series to deliver compliant RS-232 performance from a single power supply ranging from +3.0V to +5.5V. The AUTO ON-LINE feature allows the device to automatically "wake-up" during a shutdown state when an RS-232 cable is connected and a connected peripheral is turned on. Otherwise, the device automatically shuts itself down, drawing less than 1 $\mu$ A.

## Features

- Meets true EIA / TIA-232-F standards from a +3.0V to +5.5V power supply
- Interoperable with EIA / TIA-232 and adheres to EIA / TIA-562 down to a +2.7V power source
- AUTO ON-LINE<sup>®</sup> circuitry automatically wakes up from a 1 $\mu$ A shutdown
- Regulated Charge Pump yields stable RS-232 outputs regardless of  $V_{CC}$  variations
- Enhanced ESD specifications:
  - $\pm 15$ kV Human Body Model
  - $\pm 15$ kV IEC61000-4-2 Air Discharge
  - $\pm 8$ kV IEC61000-4-2 Contact Discharge
- 250kbps minimum transmission rate (EB)
- 1000kbps minimum transmission rate (EU)
- Ideal for high speed RS-232 applications

Ordering Information - [page 23](#)

## Selection Table

**Table 1: SP3243E Selection Table**

Device	Power Supplies	RS-232 Drivers	RS-232 Receivers	External Components	Auto On-Line Circuitry	TTL 3-State	# of Pins	Data Rate (kbps)	ESD Rating
SP3243E	+3.0V to +5.5V	3	5	4 capacitors	Yes	Yes	28	120	15kV
SP3243EB	+3.0V to +5.5V	3	5	4 capacitors	Yes	Yes	28	250	15kV
SP3243EH	+3.0V to +5.5V	3	5	4 capacitors	Yes	Yes	28	460	15kV
SP3243EU	+3.0V to +5.5V	3	5	4 capacitors	Yes	Yes	28	1000	15kV

## Revision History

Revision	Release Date	Change Description
--	02/05/06	Legacy Sipex Datasheet
1.0.0	7/23/09	Convert to Exar Format, Update ordering information and change revision to 1.0.0.
1.0.1	11/10/09	Add missing (EH) model identification for Driver output Skew and Transition-Region Slew Rate specification and change revision to 1.0.1.
1.0.2	06/06/11	Remove obsolete devices per PDN 110510-01 and change ESD rating to IEC61000-4-2.
1.0.3	5/24/19	Convert to MaxLinear format. Update Ordering Information and remove obsolete devices. Move pinouts to Pin Information section. Add ESD rating table to Absolute Maximum section. Remove obsolete WSOIC28 package information.

# Table of Contents

<b>General Description</b> .....	<b>i</b>
<b>Features</b> .....	<b>i</b>
<b>Selection Table</b> .....	<b>i</b>
<b>Specifications</b> .....	<b>1</b>
Absolute Maximum Ratings.....	1
ESD Ratings.....	1
Electrical Characteristics .....	2
<b>Typical Performance Characteristics</b> .....	<b>4</b>
<b>Pin Information</b> .....	<b>5</b>
Pin Configuration.....	5
Pin Descriptions .....	6
<b>Typical Operating Circuit</b> .....	<b>7</b>
<b>Description</b> .....	<b>8</b>
<b>Theory of Operation</b> .....	<b>9</b>
Drivers .....	9
Receivers .....	10
Charge Pump .....	10
Phase 1: $V_{SS}$ Charge Storage.....	10
Phase 2: $V_{SS}$ Transfer.....	10
Phase 3: $V_{DD}$ Charge Storage .....	11
Phase 4: $V_{DD}$ Transfer .....	11
AUTO ONLINE Circuitry.....	11
ESD Tolerance .....	15
<b>Mechanical Dimensions</b> .....	<b>17</b>
QFN32.....	17
<b>Recommended Land Pattern and Stencil</b> .....	<b>18</b>
QFN32.....	18
<b>Mechanical Dimensions</b> .....	<b>19</b>
SSOP28 .....	19
<b>Recommended Land Pattern and Stencil</b> .....	<b>20</b>
SSOP28 .....	20
<b>Mechanical Dimensions</b> .....	<b>21</b>
TSSOP28 .....	21

---

<b>Recommended Land Pattern and Stencil</b> .....	<b>22</b>
TSSOP28 .....	22
<b>Ordering Information</b> .....	<b>23</b>

## List of Figures

Figure 1: Transmitter Skew vs. Load Capacitance .....	4
Figure 2: Transmitter Output Voltage vs. Supply Voltage for the SP3243EU.....	4
Figure 3: Transmitter Output Voltage vs. Load Capacitance for the SP3243EU.....	4
Figure 4: Supply Current vs. Load Capacitance for the SP3243EU .....	4
Figure 5: Supply Current vs. Supply Voltage for the SP3243EU.....	4
Figure 6: Transmitter Output Voltage vs. Load Capacitance for the SP3243EB .....	4
Figure 7: Slew Rate vs. Load Capacitance.....	5
Figure 8: SP3243E Pinout (Top View) SSOP / TSSOP.....	5
Figure 9: SP3243E Pinout (Top View) QFN32 .....	5
Figure 10: SP3243E Typical Operating Circuit .....	7
Figure 11: Interface Circuitry Controlled by Microprocessor Supervisory Circuit .....	8
Figure 12: Loopback Test Circuit for RS-232 Driver Data Transmission Rates .....	9
Figure 13: Loopback Test Results at 1Mbps .....	9
Figure 14: Loopback Test Results at 250kbps .....	9
Figure 15: Charge Pump — Phase 1.....	10
Figure 16: Charge Pump — Phase 2.....	10
Figure 17: Charge Pump — Phase 3.....	11
Figure 18: Charge Pump — Phase 4.....	11
Figure 19: AUTO ON-LINE Timing Waveforms .....	12
Figure 20: SP3243E Driver Output Voltages vs. Load Current per Transmitter .....	12
Figure 21: Mouse Drive Application.....	13
Figure 22: Attaching SP3243E to a DB-9 Connector.....	13
Figure 23: Stage I of AUTO ON-LINE Circuitry .....	14
Figure 24: Stage II of AUTO ON-LINE Circuitry .....	14
Figure 25: ESD Test Circuit for Human Body Model .....	16
Figure 26: ESD Test Circuit for IEC61000-4-2 .....	16
Figure 27: ESD Test Waveform for IEC61000-4-2 .....	16
Figure 28: Mechanical Dimensions, QFN32 .....	17
Figure 29: Recommended Land Pattern and Stencil, QFN32 .....	18
Figure 30: Mechanical Dimensions, SSOP28.....	19
Figure 31: Recommended Land Pattern and Stencil, SSOP28.....	20
Figure 32: Mechanical Dimensions, TSSOP28 .....	21
Figure 33: Recommended Land Pattern and Stencil, TSSOP28.....	22
Figure 34: Part Nomenclature.....	24

## List of Tables

Table 1: SP3243E Selection Table.....	i
Table 2: Absolute Maximum Ratings .....	1
Table 3: ESD Ratings .....	1
Table 4: Electrical Characteristics .....	2
Table 5: Device Pin Descriptions.....	6
Table 6: SP3243E SHUTDOWN Truth Table .....	10
Table 7: Minimum Recommended Charge Pump Capacitor Value .....	11
Table 8: AUTO ON-LINE Logic.....	14
Table 9: Transceiver ESD Tolerance Levels .....	16
Table 10: Ordering Information.....	23

## Specifications

### Absolute Maximum Ratings

**Important:** These are stress ratings only and functional operation of the device at these ratings or any other above those indicated in the operation sections of the specifications below is not implied. Exposure to absolute maximum ratings conditions for extended periods of time may affect reliability and cause permanent damage to the device.

**Table 2: Absolute Maximum Ratings**

Parameter	Minimum	Maximum	Units
$V_{CC}$	-0.3	6.0	V
$V_{+}^{(1)}$	-0.3	7.0	V
$V_{-}^{(1)}$	+0.3	-7.0	V
$V_{+} +  V_{-} ^{(1)}$		+13	V
$I_{CC}$ (DC $V_{CC}$ or GND current)		$\pm 100$	mA
Input Voltages			
TxIN, <u>ONLINE</u> , <u>SHUTDOWN</u>	-0.3	$V_{CC} + 6.0$	V
RxIN		$\pm 15$	V
Output Voltages			
TxOUT		$\pm 13.2$	V
RxOUT, <u>STATUS</u>	-0.3	$V_{CC} + 0.3$	V
Short-Circuit Duration			
TxOUT		Continuous	
Temperature			
Storage temperature	-65	150	$^{\circ}\text{C}$
Power Dissipation per Package			
28-pin SSOP (derate 11.2mW/ $^{\circ}\text{C}$ above +70 $^{\circ}\text{C}$ )		900	mW
28-pin TSSOP (derate 13.2mW/ $^{\circ}\text{C}$ above +70 $^{\circ}\text{C}$ )		1059	mW
32-pin QFN (derate 29.4mW/ $^{\circ}\text{C}$ above +70 $^{\circ}\text{C}$ )		2352	mW

1.  $V_{+}$  and  $V_{-}$  can have maximum magnitudes of 7V, but their absolute difference cannot exceed 13V.

### ESD Ratings

**Table 3: ESD Ratings**

Parameter	Level	Value	Units
HBM — Human Body Model (driver outputs and receiver inputs)		$\pm 15$	kV
IEC61000-4-2 Air Discharge (driver outputs and receiver inputs)	4	$\pm 15$	kV
IEC61000-4-2 Contact Discharge (driver outputs and receiver inputs)	4	$\pm 8$	kV

## Electrical Characteristics

Unless otherwise noted, the following specifications apply for  $V_{CC} = +3.0V$  to  $+5.5V$  with  $T_{AMB} = T_{MIN}$  to  $T_{MAX}$ ,  $C1 - C4 = 0.1\mu F$ . Typical values apply at  $V_{CC} = +3.3V$  or  $+5.0V$  and  $T_{AMB} = 25^{\circ}C$ .

**Table 4: Electrical Characteristics**

Parameter	Test Condition	Minimum	Typical	Maximum	Units
DC Characteristics					
Supply current, AUTO ON-LINE	All RxIN open, $\overline{ONLINE} = GND$ , $\overline{SHUTDOWN} = V_{CC}$ , $V_{CC} = 3.3V$ , $T_{AMB} = 25^{\circ}C$ , $TxIN = GND$ or $V_{CC}$		1.0	10	$\mu A$
Supply current, shutdown	$\overline{SHUTDOWN} = GND$ , $V_{CC} = 3.3V$ , $T_{AMB} = 25^{\circ}C$ , $TxIN = V_{CC}$ or $GND$		1.0	10	$\mu A$
Supply current, AUTO ON-LINE disabled	$\overline{ONLINE} = \overline{SHUTDOWN} = V_{CC}$ , no load, $V_{CC} = 3.3V$ , $T_{AMB} = +25^{\circ}C$ , $TxIN = GND$ or $V_{CC}$		0.3	1.0	mA
Logic Inputs and Receiver Outputs					
Input logic threshold	Low	$V_{CC} = 3.3V$ or $5.0V$ , $TxIN$ , $\overline{ONLINE}$ , $\overline{SHUTDOWN}$		0.8	V
	High		2.4		V
Input leakage current	$TxIN$ , $\overline{ONLINE}$ , $\overline{SHUTDOWN}$ , $T_{AMB} = +25^{\circ}C$ , $V_{IN} = 0V$ to $V_{CC}$		$\pm 0.01$	$\pm 1.0$	$\mu A$
Output leakage current	Receivers disabled, $V_{OUT} = 0V$ to $V_{CC}$		$\pm 0.05$	$\pm 10$	$\mu A$
Output voltage Low	$I_{OUT} = 1.6mA$			0.4	V
Output voltage High	$I_{OUT} = -1.0mA$	$V_{CC} - 0.6$	$V_{CC} - 0.1$		V
Driver Outputs					
Output voltage swing	All driver outputs loaded with $3k\Omega$ to GND, $T_{AMB} = +25^{\circ}C$	$\pm 5.0$	$\pm 5.4$		V
Output resistance	$V_{CC} = V+ = V- = 0V$ , $V_{OUT} = \pm 2V$	300			$\Omega$
Output short-circuit current	$V_{OUT} = 0V$		$\pm 35$	$\pm 60$	mA
Output leakage current	$V_{CC} = 0V$ or $3.0V$ to $5.5V$ , $V_{OUT} = \pm 12V$ , drivers disabled			$\pm 25$	$\mu A$
Receiver Inputs					
Input voltage range		-15		15	V
Input threshold Low	$V_{CC} = 3.3V$	0.6	1.2		V
	$V_{CC} = 5.0V$	0.8	1.5		V
Input threshold High	$V_{CC} = 3.3V$		1.5	2.4	V
	$V_{CC} = 5.0V$		1.8	2.4	V
Input hysteresis			0.3		V
Input resistance		3	5	7	k $\Omega$

**Table 4: (Continued) Electrical Characteristics**

Parameter	Test Condition	Minimum	Typical	Maximum	Units	
AUTO ON-LINE Circuitry Characteristics ( $\overline{\text{ONLINE}} = \text{GND}$ , $\overline{\text{SHUTDOWN}} = V_{\text{CC}}$ ) 25°C						
STATUS output voltage Low	$I_{\text{OUT}} = 1.6\text{mA}$			0.4	V	
STATUS output voltage High	$I_{\text{OUT}} = -1.0\text{mA}$	$V_{\text{CC}} - 0.6$			V	
Receiver threshold to drivers enabled ( $t_{\text{ONLINE}}$ )	Figure 19		350		$\mu\text{s}$	
Receiver positive or negative threshold to STATUS High ( $t_{\text{STSH}}$ )	Figure 19		0.2		$\mu\text{s}$	
Receiver positive or negative threshold to STATUS Low ( $t_{\text{STSL}}$ )	Figure 19		30		$\mu\text{s}$	
Timing Characteristics						
Maximum data rate	U	$R_{\text{L}} = 3\text{k}\Omega$ , $C_{\text{L}} = 250\text{pF}$ , one driver active	1000			kbps
	H	$R_{\text{L}} = 3\text{k}\Omega$ , $C_{\text{L}} = 1000\text{pF}$ , one driver active	460			kbps
	B	$R_{\text{L}} = 3\text{k}\Omega$ , $C_{\text{L}} = 1000\text{pF}$ , one driver active	250			kbps
	-	$R_{\text{L}} = 3\text{k}\Omega$ , $C_{\text{L}} = 1000\text{pF}$ , one driver active	120			kbps
Receiver propagation delay	$t_{\text{PHL}}$	Receiver input to receiver output, $C_{\text{L}} = 150\text{pF}$		0.15		$\mu\text{s}$
	$t_{\text{PLH}}$			0.15		$\mu\text{s}$
Receiver output enable time		Normal operation		200		ns
Receiver output disable time		Normal operation		200		ns
Driver skew	E, EB	$ t_{\text{PHL}} - t_{\text{PLH}} $		100	500	ns
	EH, EU			50	100	ns
Receiver skew		$ t_{\text{PHL}} - t_{\text{PLH}} $		50		ns
Transition-region slew rate	EH, EU	$V_{\text{CC}} = 3.3\text{V}$ , $R_{\text{L}} = 3\text{k}\Omega$ , $T_{\text{AMB}} = 25^\circ\text{C}$ , measurements taken from -3.0V to +3.0V or +3.0V to -3.0V		90		V/ $\mu\text{s}$
	E, EB		6		30	V/ $\mu\text{s}$

# Typical Performance Characteristics

Unless otherwise noted, the following performance characteristics apply for  $V_{CC} = +3.3V$ , 1000kbps data rate, all drivers loaded with  $3k\Omega$ ,  $0.1\mu F$  charge pump capacitors, and  $T_{AMB} = +25^{\circ}C$ .



**Figure 1: Transmitter Skew vs. Load Capacitance**

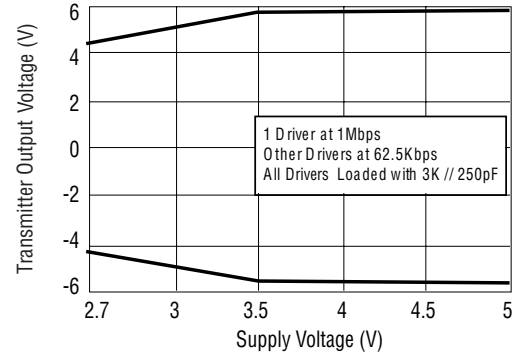

**Figure 2: Transmitter Output Voltage vs. Supply Voltage for the SP3243EU**

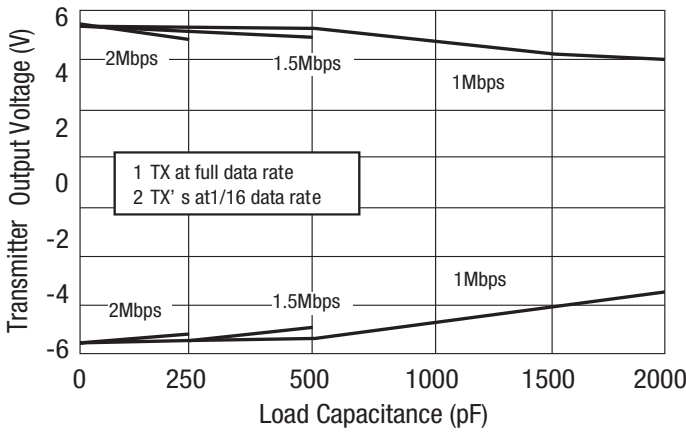

**Figure 3: Transmitter Output Voltage vs. Load Capacitance for the SP3243EU**

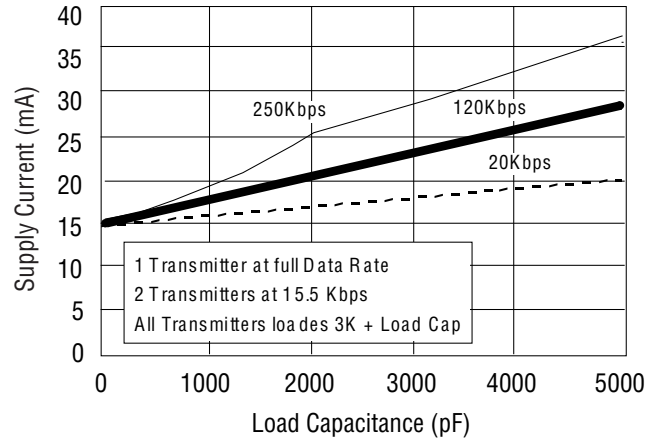

**Figure 4: Supply Current vs. Load Capacitance for the SP3243EU**

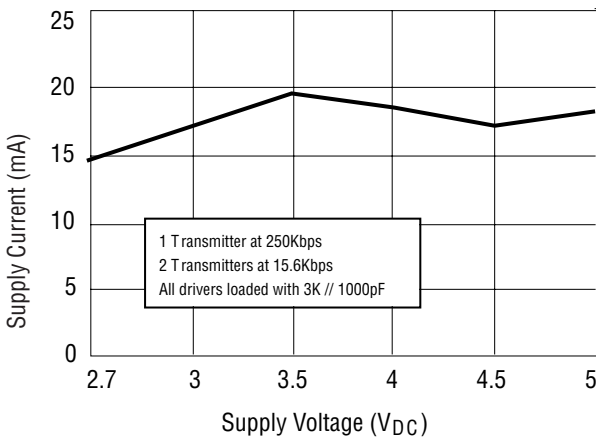

**Figure 5: Supply Current vs. Supply Voltage for the SP3243EU**

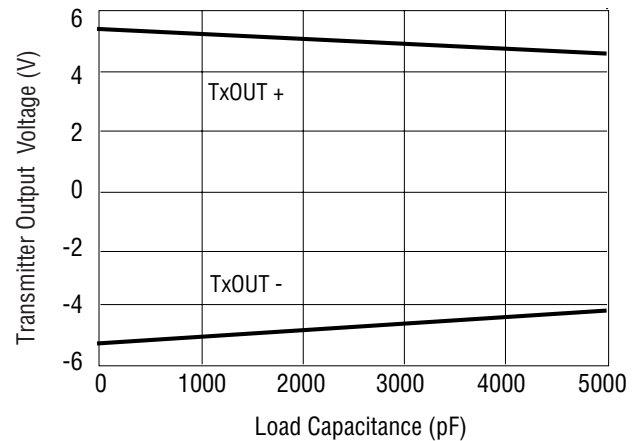

**Figure 6: Transmitter Output Voltage vs. Load Capacitance for the SP3243EB**



**Figure 7: Slew Rate vs. Load Capacitance**

## Pin Information

### Pin Configuration

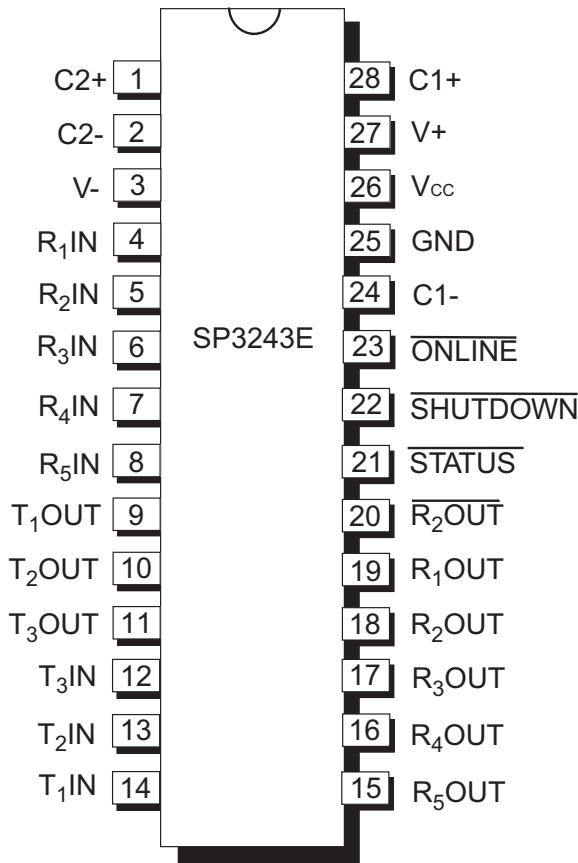

**Figure 8: SP3243E Pinout (Top View) SSOP / TSSOP**



**Figure 9: SP3243E Pinout (Top View) QFN32**

## Pin Descriptions

**Table 5: Device Pin Descriptions**

Name	Function	Pin Number	
		SP3243E SSOP and TSSOP	SP3243EUCR QFN
C1+	Positive terminal of the voltage doubler charge-pump capacitor	28	28
V+	Regulated +5.5V output generated by the charge pump	27	26
C1-	Negative terminal of the voltage doubler charge-pump capacitor	24	22
C2+	Positive terminal of the inverting charge-pump capacitor	1	29
C2-	Negative terminal of the inverting charge-pump capacitor	2	31
V-	Regulated -5.5V output generated by the charge pump	3	32
R <sub>1</sub> IN	RS-232 receiver input	4	2
R <sub>2</sub> IN	RS-232 receiver input	5	3
R <sub>3</sub> IN	RS-232 receiver input	6	4
R <sub>4</sub> IN	RS-232 receiver input	7	5
R <sub>5</sub> IN	RS-232 receiver input	8	6
R <sub>1</sub> OUT	TTL / CMOS receiver output	19	17
R <sub>2</sub> OUT	TTL / CMOS receiver output	18	16
$\overline{R_2}$ OUT	Non-inverting receiver-2 output, active in shutdown	20	18
R <sub>3</sub> OUT	TTL / CMOS receiver output	17	15
R <sub>4</sub> OUT	TTL / CMOS receiver output	16	14
R <sub>5</sub> OUT	TTL / CMOS receiver output	15	13
$\overline{STATUS}$	TTL / CMOS output indicating online and shutdown status	21	19
T <sub>1</sub> IN	TTL / CMOS driver input	14	12
T <sub>2</sub> IN	TTL / CMOS driver input	13	11
T <sub>3</sub> IN	TTL / CMOS driver input	12	10
$\overline{ONLINE}$	Apply logic HIGH to override AUTO ON-LINE circuitry keeping drivers active ( $\overline{SHUTDOWN}$ must also be logic HIGH, refer to <a href="#">Table 6</a> )	23	21
T <sub>1</sub> OUT	RS-232 driver output	9	7
T <sub>2</sub> OUT	RS-232 driver output	10	8
T <sub>3</sub> OUT	RS-232 driver output	11	9
GND	Ground	25	23
V <sub>CC</sub>	+3.0V to +5.5V supply voltage	26	25
$\overline{SHUTDOWN}$	Apply logic LOW to $\overline{SHUTDOWN}$ driver and charge pump. This overrides all AUTO ON-LINE circuitry and $\overline{ONLINE}$ (Refer to <a href="#">Table 6</a> )	22	20
NC	No connection	-	1, 24, 27, 30

## Typical Operating Circuit

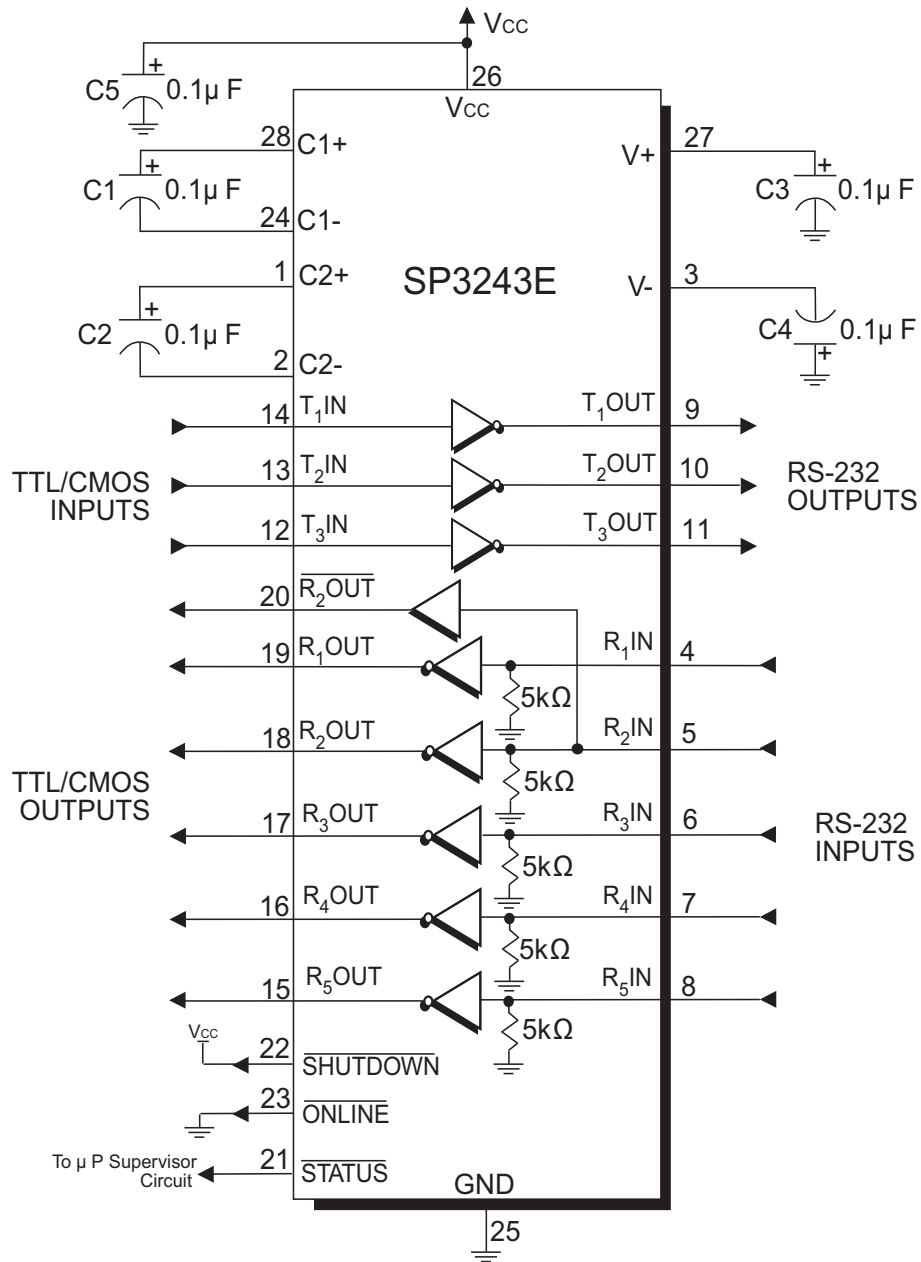

**Figure 10: SP3243E Typical Operating Circuit**

## Description

The SP3243E transceivers meet the EIA / TIA-232 and ITU-T V.28 / V.24 communication protocols and can be implemented in battery-powered, portable or hand-held applications such as notebook or palmtop computers. The SP3243E devices feature MaxLinear's proprietary and patented (U.S. 5,306,954) on-board charge pump circuitry that generates  $\pm 5.5V$  RS-232 voltage levels from a single +3.0V to +5.5V power supply. The SP3243EU device can operate at a data rate of 1000kbps fully loaded.

The SP3243E is a 3-driver / 5-receiver device, ideal for portable or hand-held applications. The SP3243E includes one complementary always-active receiver that can monitor an external device (such as a modem) in shutdown. This aids in protecting the UART or serial

controller IC by preventing forward biasing of the protection diodes where  $V_{CC}$  may be disconnected.

The SP3243E series is an ideal choice for power sensitive designs. The SP3243E devices feature AUTO ON-LINE circuitry which reduces the power supply drain to a  $1\mu A$  supply current.

In many portable or hand-held applications, an RS-232 cable can be disconnected or a connected peripheral can be turned off. Under these conditions, the internal charge pump and the drivers will be shut down. Otherwise, the system automatically comes online. This feature allows design engineers to address power saving concerns without major design changes.

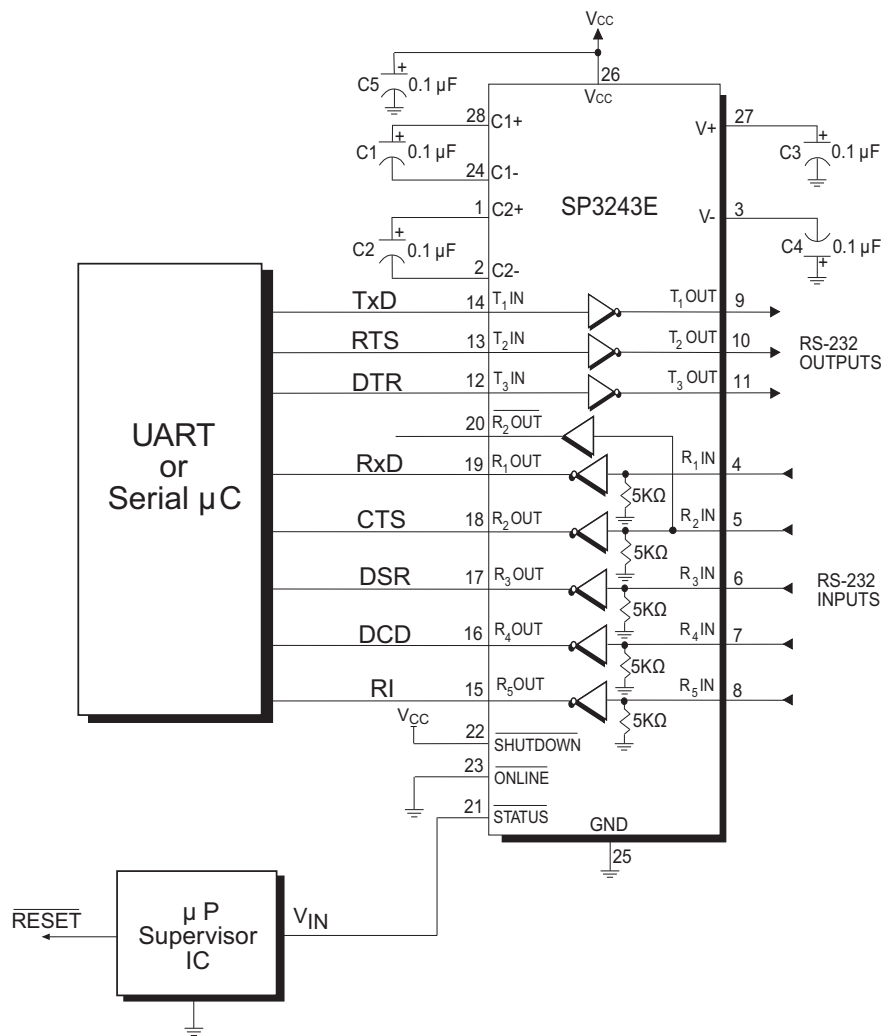

**Figure 11: Interface Circuitry Controlled by Microprocessor Supervisory Circuit**

# Theory of Operation

The SP3243E series is made up of four basic circuit blocks:

1. Drivers
2. Receivers
3. The MaxLinear proprietary charge pump
4. AUTO ON-LINE circuitry

## Drivers

The drivers are inverting level transmitters that convert TTL or CMOS logic levels to 5.0V EIA / TIA-232 levels with an inverted sense relative to the input logic levels. Typically, the RS-232 output voltage swing is  $\pm 5.4V$  with no load and  $\pm 5V$  minimum fully loaded. The driver outputs are protected against infinite short-circuits to ground without degradation in reliability. These drivers comply with the EIA-TIA-232-F and all previous RS-232 versions. Unused drivers inputs should be connected to GND or  $V_{CC}$ .

The drivers have a minimum data rate of 250kbps (EB) or 1000kbps (EU) fully loaded.

Figure 12 shows a loopback test circuit used to test the RS-232 Drivers. Figure 13 shows the test results where one driver was active at 1Mbps and all three drivers were loaded with an RS-232 receiver in parallel with a 250pF capacitor. Figure 14 shows the test results of the loopback circuit with all drivers active at 250kbps with typical RS-232 loads in parallel with 1000pF capacitors. A superior RS-232 data transmission rate of 1Mbps makes the SP3243EU an ideal match for high speed LAN and personal computer peripheral applications.

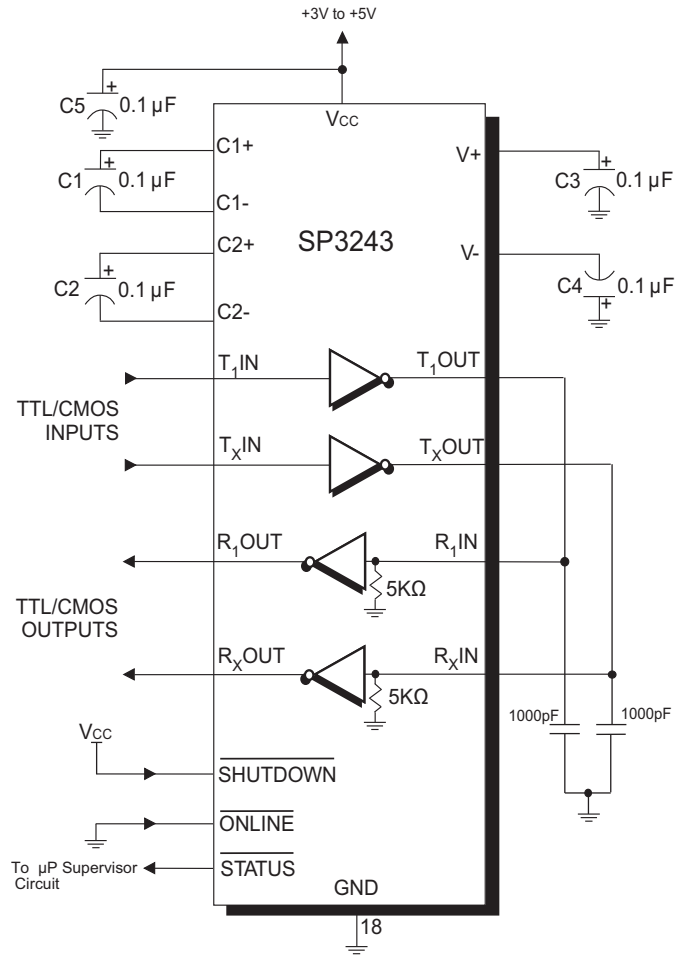

**Figure 12: Loopback Test Circuit for RS-232 Driver Data Transmission Rates**

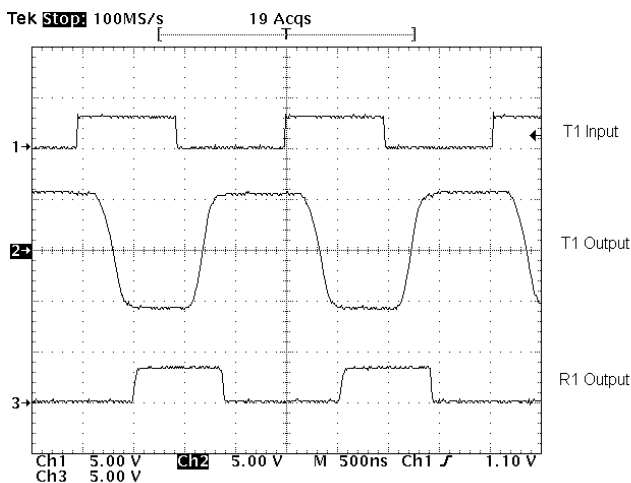

**Figure 13: Loopback Test Results at 1Mbps**

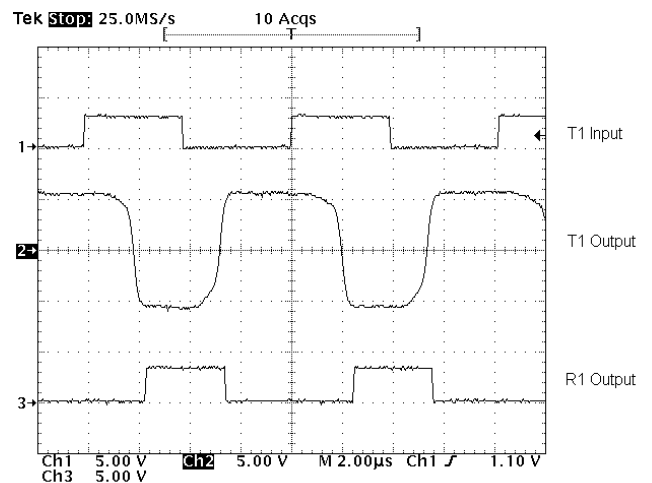

**Figure 14: Loopback Test Results at 250kbps**

## Receivers

The receivers convert  $\pm 5.0\text{V}$  EIA / TIA-232 levels to TTL or CMOS logic output levels. Receivers are High-Z when the AUTO ON-LINE circuitry is enabled or when in shutdown. The truth table logic of the SP3243 driver and receiver outputs can be found in [Table 6](#).

**Table 6: SP3243E SHUTDOWN Truth Table**

SHUTDOWN	TxOUT	RxOUT	R2OUT
0	High-Z	High-Z	Active
1	Active	Active	Active

1. In AUTO ON-LINE Mode where  $\overline{\text{ONLINE}} = \text{GND}$  and  $\overline{\text{SHUTDOWN}} = V_{\text{CC}}$ , the device will shut down if there is no activity present at the receiver inputs.

The SP3243E includes an additional non-inverting receiver with an output  $\overline{\text{R}}_2\text{OUT}$ .  $\overline{\text{R}}_2\text{OUT}$  is an extra output that remains active and monitors activity while the other receiver outputs are forced into high impedance. This allows a Ring Indicator (RI) signal from a peripheral to be monitored without forward biasing the TTL / CMOS inputs of the other devices connected to the receiver outputs.

Since receiver input is usually from a transmission line where long cable lengths and system interference can degrade the signal, the inputs have a typical hysteresis margin of 300mV. This ensures that the receiver is virtually immune to noisy transmission lines. Should an input be left unconnected, an internal 5k $\Omega$  pull-down resistor to ground will commit the output of the receiver to a HIGH state.

## Charge Pump

The charge pump is a MaxLinear-patented design (U.S. 5,306,954) and uses a unique approach compared to older, less-efficient designs. The charge pump still requires four external capacitors, but uses a four-phase voltage shifting technique to attain symmetrical 5.5V power supplies. The internal power supply consists of a regulated dual charge pump that provides output voltages of 5.5V regardless of the input voltage ( $V_{\text{CC}}$ ) over the +3.0V to +5.5V range. This is important to maintain compliant RS-232 levels regardless of power supply fluctuations.

The charge pump operates in a discontinuous mode using an internal oscillator. If the output voltages are less than a magnitude of 5.5V, the charge pump is enabled. If the output voltages exceed a magnitude of 5.5V, the charge

pump is disabled. This oscillator controls the four phases of the voltage shifting. A description of each phase follows.

### Phase 1: $V_{\text{SS}}$ Charge Storage

During this phase of the clock cycle, the positive side of capacitors  $C_1$  and  $C_2$  are initially charged to  $V_{\text{CC}}$ .  $C_1^+$  is then switched to GND and the charge in  $C_1^-$  is transferred to  $C_2^-$ . Since  $C_2^+$  is connected to  $V_{\text{CC}}$ , the voltage potential across capacitor  $C_2$  is now 2 times  $V_{\text{CC}}$ .

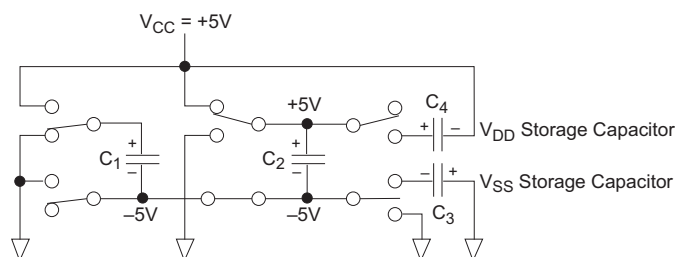

**Figure 15: Charge Pump — Phase 1**

### Phase 2: $V_{\text{SS}}$ Transfer

Phase two of the clock connects the negative terminal of  $C_2$  to the  $V_{\text{SS}}$  storage capacitor and the positive terminal of  $C_2$  to GND. This transfers a negative generated voltage to  $C_3$ . This generated voltage is regulated to a minimum voltage of -5.5V. Simultaneous with the transfer of the voltage to  $C_3$ , the positive side of capacitor  $C_1$  is switched to  $V_{\text{CC}}$  and the negative side is connected to GND.

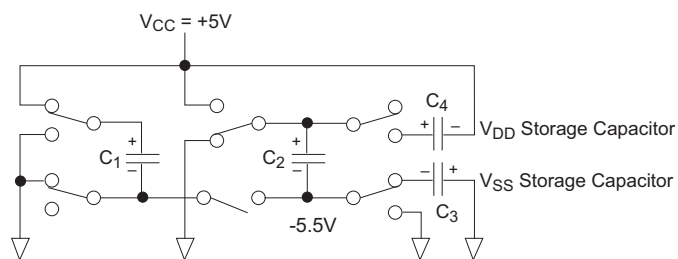

**Figure 16: Charge Pump — Phase 2**

## Phase 3: $V_{DD}$ Charge Storage

The third phase of the clock is identical to the first phase — the charge transferred in  $C_1$  produces  $-V_{CC}$  in the negative terminal of  $C_1$ , which is applied to the negative side of capacitor  $C_2$ . Since  $C_2^+$  is at  $V_{CC}$ , the voltage potential across  $C_2$  is 2 times  $V_{CC}$ .

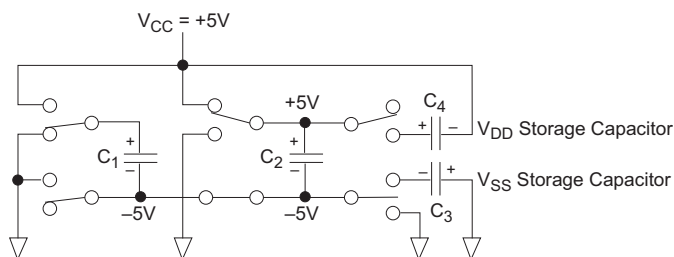

**Figure 17: Charge Pump — Phase 3**

## Phase 4: $V_{DD}$ Transfer

The fourth phase of the clock connects the negative terminal of  $C_2$  to GND, and transfers this positive generated voltage across  $C_2$  to  $C_4$ , the  $V_{DD}$  storage capacitor. This voltage is regulated to +5.5V. At this voltage, the internal oscillator is disabled. Simultaneous with the transfer of the voltage to  $C_4$ , the positive side of capacitor  $C_1$  is switched to  $V_{CC}$  and the negative side is connected to GND, allowing the charge pump cycle to begin again. The charge pump cycle will continue as long as the operational conditions for the internal oscillator are present.



**Figure 18: Charge Pump — Phase 4**

Since both  $V^+$  and  $V^-$  are separately generated from  $V_{CC}$ , in a no-load condition  $V^+$  and  $V^-$  will be symmetrical. Older charge pump approaches that generate  $V^-$  from  $V^+$  will show a decrease in the magnitude of  $V^-$  compared to  $V^+$  due to the inherent inefficiencies in the design. The

clock rate for the charge pump typically operates at greater than 250kHz. The external capacitors can be as low as  $0.1\mu\text{F}$  with a 16V breakdown voltage rating.

**Table 7: Minimum Recommended Charge Pump Capacitor Value**

Input Voltage $V_{CC}$	Charge Pump Capacitor Value
3.0V to 3.6V	$C_1 - C_4 = 0.1\mu\text{F}$
4.5V to 5.5V	$C_1 = 0.047\mu\text{F}$ , $C_2 - C_4 = 0.33\mu\text{F}$
3.0V to 5.5V	$C_1 - C_4 = 0.22\mu\text{F}$

The MaxLinear-patented charge pumps are designed to operate reliably with a range of low cost capacitors. Either polarized or non polarized capacitors may be used. If polarized capacitors are used they should be oriented as shown in the Typical Operating Circuit. The  $V^+$  capacitor may be connected to either ground or  $V_{CC}$  (polarity reversed.)

The charge pump operates with  $0.1\mu\text{F}$  capacitors for 3.3V operation. For other supply voltages, see the table for required capacitor values. Do not use values smaller than those listed. Increasing the capacitor values (for example, by doubling in value) reduces ripple on the transmitter outputs and may slightly reduce power consumption.  $C_2$ ,  $C_3$ , and  $C_4$  can be increased without changing  $C_1$ 's value.

For best charge pump efficiency, locate the charge pump and bypass capacitors as close as possible to the IC. Surface mount capacitors are best for this purpose. Using capacitors with lower equivalent series resistance (ESR) and self-inductance, along with minimizing parasitic PCB trace inductance, will optimize charge pump operation. Designers are also advised to consider that capacitor values may shift over time and operating temperature.

## AUTO ONLINE Circuitry

The SP3243E devices have a patent pending AUTO ONLINE circuitry on board that saves power in applications such as laptop computers, palmtop (PDA) computers and other portable systems.

The SP3243E devices incorporate an AUTO ON-LINE circuit that automatically enables itself when the external transmitters are enabled and the cable is connected. Conversely, the AUTO ON-LINE circuit also disables most of the internal circuitry when the device is not being used and goes into a standby mode where the device typically draws  $1\mu\text{A}$ . This function is externally controlled by the ONLINE pin. When this pin is tied to a logic LOW, the

AUTO ON-LINE function is active. Once active, the device is enabled until there is no activity on the receiver inputs. The receiver input typically sees at least  $\pm 3V$ , which is generated from the transmitters at the other end of the cable with a  $\pm 5V$  minimum.

When the external transmitters are disabled or the cable is disconnected, the receiver inputs will be pulled down by their internal  $5k\Omega$  resistors to ground. When this occurs over a period of time, the internal transmitters will be disabled and the device goes into a shutdown or standby mode. When ONLINE is HIGH, the AUTO ON-LINE mode is disabled.

The AUTO ON-LINE circuit has two stages:

1. Inactive Detection
2. Accumulated Delay

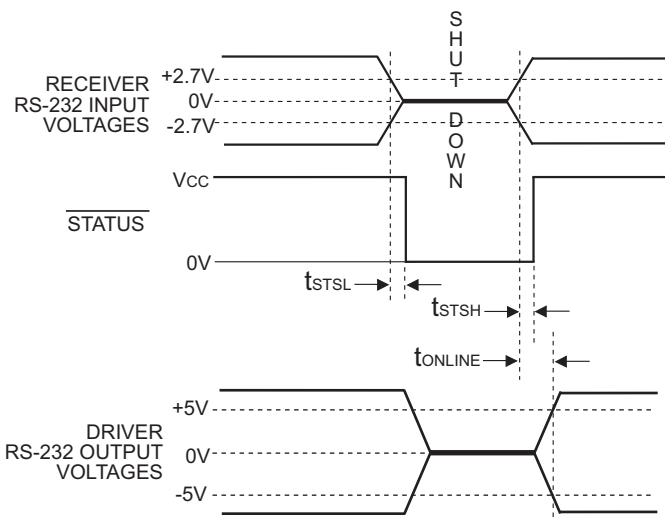

**Figure 19: AUTO ON-LINE Timing Waveforms**

The first stage, shown in Figure 23, detects an inactive input. A logic HIGH is asserted on  $R_XINACT$  if the cable is disconnected or the external transmitters are disabled. Otherwise,  $R_XINACT$  will be at a logic LOW. This circuit is duplicated for each of the other receivers.

The second stage of the AUTO ON-LINE circuitry, shown in Figure 24, processes all the receiver's  $R_XINACT$  signals with an accumulated delay that disables the device to a  $1\mu A$  supply current.

The STATUS pin goes to a logic LOW when the cable is disconnected, the external transmitters are disabled, or the SHUTDOWN pin is invoked. The typical accumulated delay is around  $20\mu s$ .

When the SP3243E drivers or internal charge pump are

disabled, the supply current is reduced to  $1\mu A$ . This can commonly occur in hand-held or portable applications where the RS-232 cable is disconnected or the RS-232 drivers of the connected peripheral are turned off.

The AUTO ON-LINE mode can be disabled by the SHUTDOWN pin. If this pin is a logic LOW, the AUTO ON-LINE function will not operate regardless of the logic state of the ONLINE pin. Table 8 summarizes the logic of the AUTO ON-LINE operating modes. The truth table logic of the SP3243E driver and receiver outputs can be found in Table 6.

The STATUS pin outputs a logic LOW signal if the device is shutdown. This pin goes to a logic HIGH when the external transmitters are enabled and the cable is connected.

When the SP3243E devices are shut down, the charge pumps are turned off.  $V^+$  charge pump output decays to  $V_{CC}$ , the  $V^-$  output decays to GND. The decay time will depend on the size of capacitors used for the charge pump. Once in shutdown, the time required to exit the shutdown state and have valid  $V^+$  and  $V^-$  levels is typically  $200\mu s$ .

For easy programming, the STATUS can be used to indicate DSR or a Ring Indicator signal. Tying ONLINE and SHUTDOWN together will bypass the AUTO ON-LINE circuitry so this connection acts like a shutdown input pin.

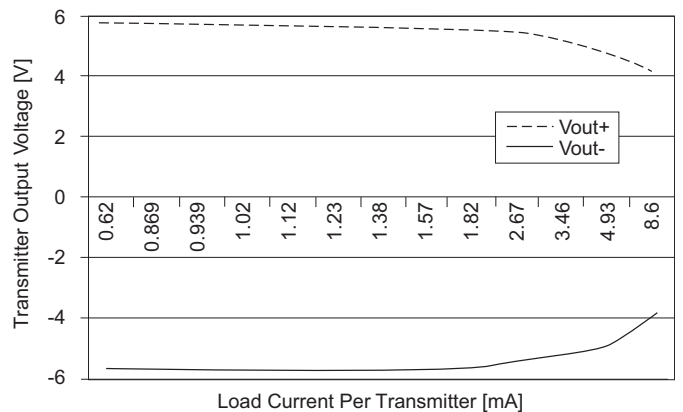
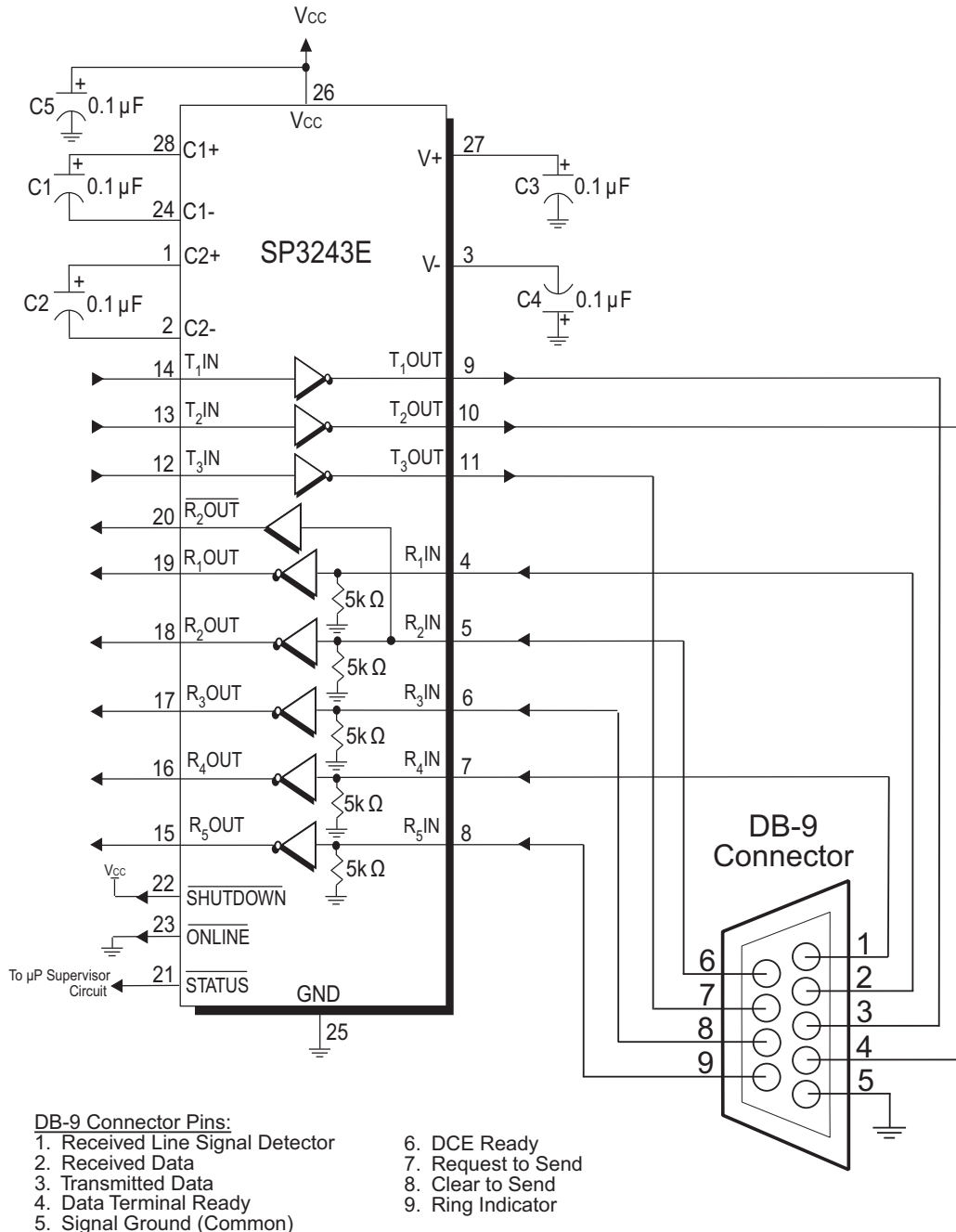

**Figure 20: SP3243E Driver Output Voltages vs. Load Current per Transmitter**

The SP3243E driver outputs are able to maintain voltage under loading of up to  $2.5mA$  per driver, ensuring sufficient output for mouse-driving applications.



**Figure 21: Mouse Drive Application**



**Figure 22: Attaching SP3243E to a DB-9 Connector**

**Table 8: AUTO ON-LINE Logic**

RS-232 Signal at Receiver Input	SHUTDOWN Input	ONLINE Input	STATUS Output	Transceiver Status
Yes	High	Low	High	Normal operation <i>(Auto-Online)</i>
No	High	High	Low	Normal operation
No	High	Low	Low	Shutdown <i>(Auto-Online)</i>
Yes	Low	High / Low	High	Shutdown
No	Low	High / Low	Low	Shutdown



**Figure 23: Stage I of AUTO ON-LINE Circuitry**

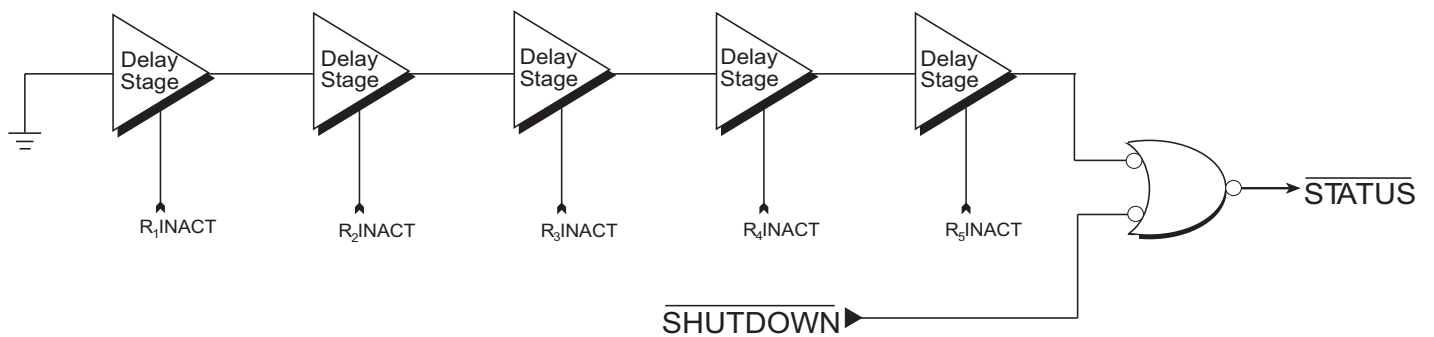

**Figure 24: Stage II of AUTO ON-LINE Circuitry**

## ESD Tolerance

The SP3243E series incorporates ruggedized ESD cells on all driver output and receiver input pins. The ESD structure is improved over our previous family for more rugged applications and environments sensitive to electro-static discharges and associated transients. The improved ESD tolerance is at least  $\pm 15\text{kV}$  without damage nor latch-up.

There are different methods of ESD testing applied:

- a. MIL-STD-883, Method 3015.7
- b. IEC61000-4-2 Air-Discharge
- c. IEC61000-4-2 Direct Contact

The Human Body Model has been the generally accepted ESD testing method for semiconductors. This method is also specified in MIL-STD-883, Method 3015.7 for ESD testing. The premise of this ESD test is to simulate the human body's potential to store electro-static energy and discharge it to an integrated circuit. The simulation is performed by using a test model as shown in [Figure 25](#). This method will test the IC's capability to withstand an ESD transient during normal handling such as in manufacturing areas where the ICs tend to be handled frequently.

The IEC-61000-4-2, formerly IEC801-2, is generally used for testing ESD on equipment and systems. For system manufacturers, they must guarantee a certain amount of ESD protection since the system itself is exposed to the outside environment and human presence. The premise with IEC61000-4-2 is that the system is required to withstand an amount of static electricity when ESD is applied to points and surfaces of the equipment that are accessible to personnel during normal usage. The transceiver IC receives most of the ESD current when the ESD source is applied to the connector pins. The test circuit for IEC61000-4-2 is shown on [Figure 26](#). There are two methods within IEC61000-4-2, the Air Discharge method and the Contact Discharge method.

With the Air Discharge Method, an ESD voltage is applied to the equipment under test (EUT) through air. This simulates an electrically charged person ready to connect a cable onto the rear of the system only to find an unpleasant zap just before the person touches the back panel. The high energy potential on the person discharges through an arcing path to the rear panel of the system before he or she even touches the system. This energy, whether discharged directly or through air, is predominantly a function of the discharge current rather than the discharge voltage. Variables with an air discharge such as approach speed of the object carrying the ESD potential to the system and

humidity will tend to change the discharge current. For example, the rise time of the discharge current varies with the approach speed.

The Contact Discharge Method applies the ESD current directly to the EUT. This method was devised to reduce the unpredictability of the ESD arc. The discharge current rise time is constant since the energy is directly transferred without the air-gap arc. In situations such as hand held systems, the ESD charge can be directly discharged to the equipment from a person already holding the equipment. The current is transferred on to the keypad or the serial port of the equipment directly and then travels through the PCB and finally to the IC.

The circuit models in [Figure 25](#) and [Figure 26](#) represent the typical ESD testing circuit used for all three methods. The  $C_S$  is initially charged with the DC power supply when the first switch (SW1) is on. Now that the capacitor is charged, the second switch (SW2) is on while SW1 switches off. The voltage stored in the capacitor is then applied through  $R_S$ , the current limiting resistor, onto the device under test (DUT). In ESD tests, the SW2 switch is pulsed so that the device under test receives a duration of voltage.

For the Human Body Model, the current limiting resistor ( $R_S$ ) and the source capacitor ( $C_S$ ) are  $1.5\text{k}\Omega$  and  $100\text{pF}$ , respectively. For IEC-61000-4-2, the current limiting resistor ( $R_S$ ) and the source capacitor ( $C_S$ ) are  $330\Omega$  and  $150\text{pF}$ , respectively.

The higher  $C_S$  value and lower  $R_S$  value in the IEC61000-4-2 model are more stringent than the Human Body Model. The larger storage capacitor injects a higher voltage to the test point when SW2 is switched on. The lower current limiting resistor increases the current charge onto the test point.



**Figure 25: ESD Test Circuit for Human Body Model**

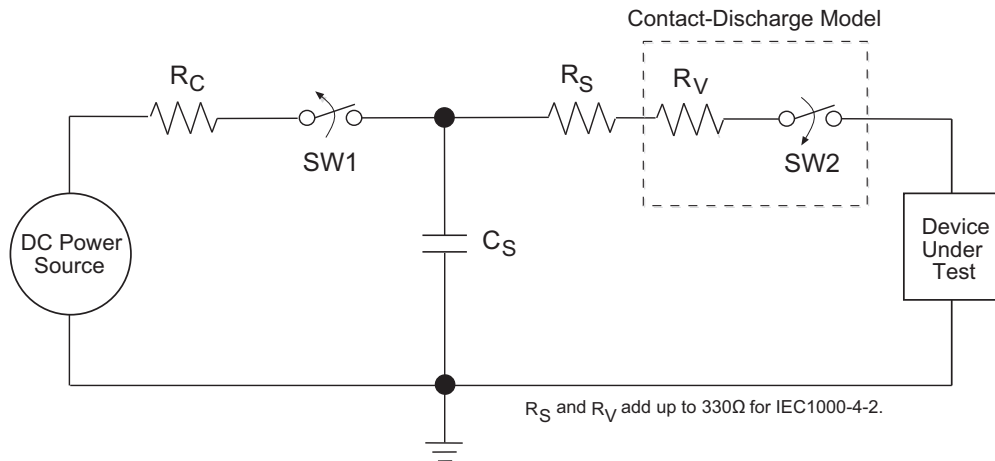

**Figure 26: ESD Test Circuit for IEC61000-4-2**

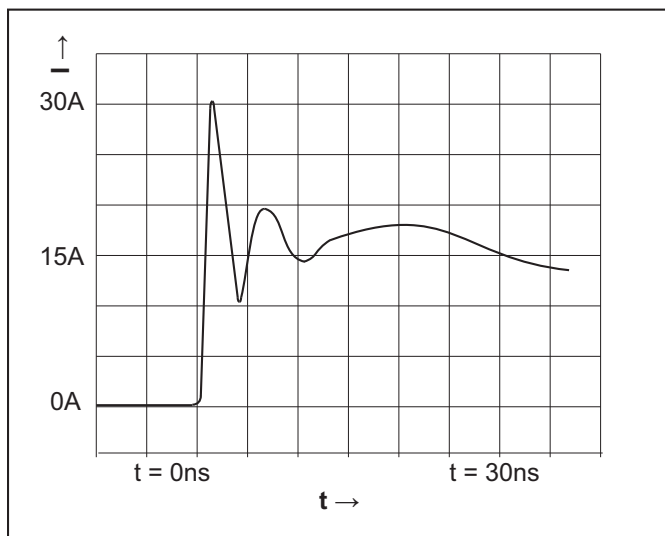

**Figure 27: ESD Test Waveform for IEC61000-4-2**

**Table 9: Transceiver ESD Tolerance Levels**

Device Pin Tested	Human Body Model	IEC 61000-4-2		
		Air Discharge	Direct Contact	Level
Driver outputs	$\pm 15kV$	$\pm 15kV$	$\pm 8kV$	4
Receiver inputs	$\pm 15kV$	$\pm 15kV$	$\pm 8kV$	4

# Mechanical Dimensions

## QFN32



DIM SYMBOL	MIN	NOM	MAX
A	0.80	0.90	1.00
A1	0.00	0.02	0.05
A3	---	0.20Ref	---
b	0.18	0.25	0.30
D	5.00 BSC		
E	5.00 BSC		
e	0.50 BSC		
D2	3.00	3.10	3.20
E2	3.00	3.10	3.20
L	0.35	0.40	0.45
K	0.20	-	-
aaa		0.15	
bbb		0.10	
ccc		0.10	
ddd		0.05	
eee		0.08	
fff		0.10	
N		32	

**TERMINAL DETAILS**

- ALL DIMENSIONS ARE IN MILLIMETERS, ANGLES ARE IN DEGREES.
- DIMENSIONS AND TOLERANCE PER JEDEC MO-220.

Drawing No.: POD-00000036

Revision: B

**Figure 28: Mechanical Dimensions, QFN32**

# Recommended Land Pattern and Stencil

## QFN32



**TYPICAL RECOMMENDED LAND PATTERN**



**TYPICAL RECOMMENDED STENCIL**

Drawing No.: POD-00000036

Revision: B

**Figure 29: Recommended Land Pattern and Stencil, QFN32**

# Mechanical Dimensions

## SSOP28

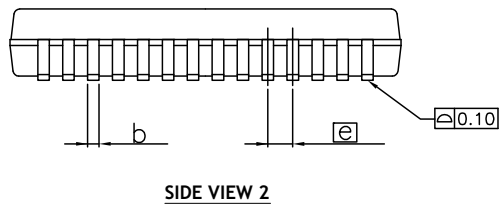
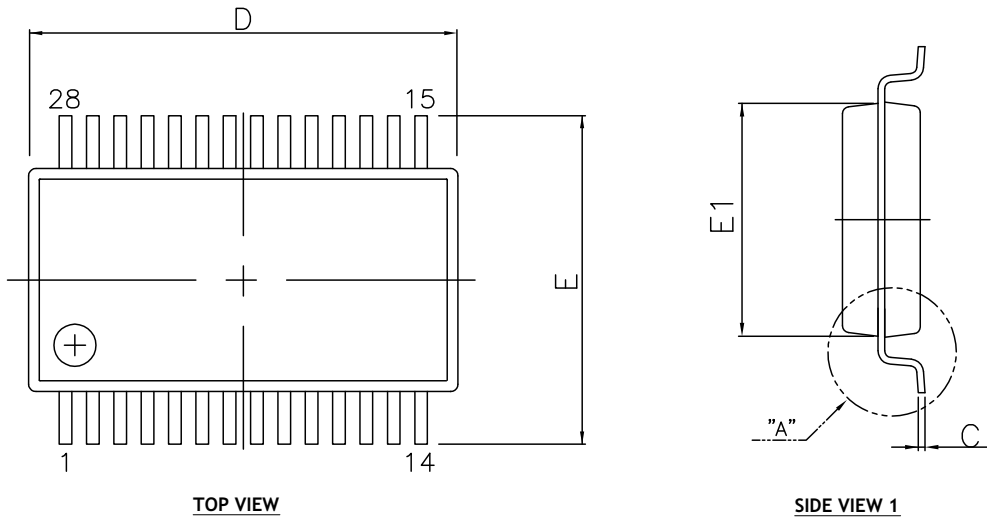

DIM SYMBOL	MIN	NOM	MAX
A	-	-	2.00
A1	0.05	-	-
A2	1.65	1.75	1.85
b	0.22	-	0.38
L1	1.25 REF		
L2	0.25 BSC		
e	0.65 BSC		
c	0.09	-	0.25
E	7.40	7.80	8.20
E1	5.00	5.30	5.60
L	0.55	0.75	0.95
R	0.09	-	-
$\theta$	0	4	8
D	9.90	10.20	10.50
N	28		

TERMINAL DETAILS

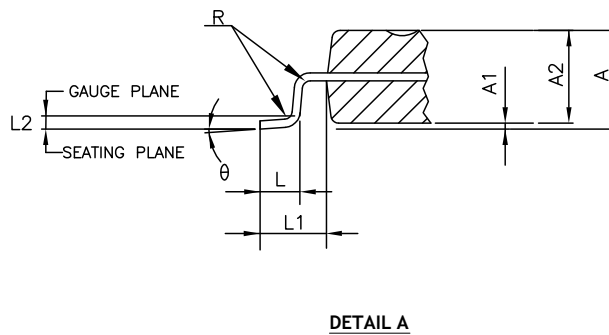

- ALL DIMENSIONS ARE IN MILLIMETERS, ANGLES ARE IN DEGREES.
- DIMENSIONS AND TOLERANCE PER JEDEC MD-150 AH.

Drawing No.: POD-000000 133

**Figure 30: Mechanical Dimensions, SSOP28**

# Recommended Land Pattern and Stencil

## SSOP28



TYPICAL RECOMMENDED LAND PATTERN



TYPICAL RECOMMENDED STENCIL

Drawing No.: POD-000000 133

Revision: A

**Figure 31: Recommended Land Pattern and Stencil, SSOP28**

# Mechanical Dimensions

## TSSOP28



DIM SYMBOL	MIN	NOM	MAX
A	-	-	1.20
A1	0.05	-	0.15
A2	0.80	1.00	1.05
b	0.19	-	0.30
L1	1.00 REF		
L2	0.25 BSC		
e	0.65 BSC		
c	0.09	-	0.20
E	6.40 BSC		
E1	4.30	4.40	4.50
L	0.45	0.60	0.75
R	0.09	-	-
D	9.60	9.70	9.80
θ1	0	4	8
θ2	12 REF		
N	28		

**TERMINAL DETAILS**

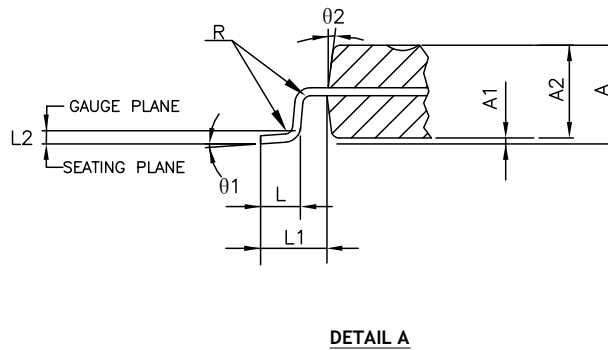

- ALL DIMENSIONS ARE IN MILLIMETERS, ANGLES ARE IN DEGREES.
- DIMENSIONS AND TOLERANCE PER JEDEC MD-153.

Drawing No.: POD-000000134

Revision: A

**Figure 32: Mechanical Dimensions, TSSOP28**

# Recommended Land Pattern and Stencil

## TSSOP28



TYPICAL RECOMMENDED LAND PATTERN



TYPICAL RECOMMENDED STENCIL

Drawing No.: POD-000000 134

Revision: A

**Figure 33: Recommended Land Pattern and Stencil, TSSOP28**

## Ordering Information

**Table 10: Ordering Information<sup>(1)</sup>**

Ordering Part Number	Operating Temperature Range	Package	Packaging Method	Lead-Free <sup>(2)</sup>
120kbps Data Rate				
SP3243ECA-L	0°C to 70°C	28-pin SSOP	Tube	Yes
SP3243ECA-L/TR	0°C to 70°C	28-pin SSOP	Reel	Yes
SP3243ECY-L/TR	0°C to 70°C	28-pin TSSOP	Reel	Yes
SP3243EEA-L	-40°C to 85°C	28-pin SSOP	Tube	Yes
SP3243EEA-L/TR	-40°C to 85°C	28-pin SSOP	Reel	Yes
SP3243EEY-L	-40°C to 85°C	28-pin TSSOP	Tube	Yes
SP3243EEY-L/TR	-40°C to 85°C	28-pin TSSOP	Reel	Yes
250kbps Data Rate				
SP3243EBCA-L/TR	0°C to 70°C	28-pin SSOP	Reel	Yes
SP3243EBCY-L/TR	0°C to 70°C	28-pin TSSOP	Reel	Yes
SP3243EBEA-L/TR	-40°C to 85°C	28-pin SSOP	Reel	Yes
SP3243EBEY-L	-40°C to 85°C	28-pin TSSOP	Tube	Yes
SP3243EBEY-L/TR	-40°C to 85°C	28-pin TSSOP	Reel	Yes
460kbps Data Rate				
SP3243EHCA-L/TR	0°C to 70°C	28-pin SSOP	Reel	Yes
SP3243EHEA-L/TR	-40°C to 85°C	28-pin SSOP	Reel	Yes
1Mbps Data Rate				
SP3243EUCA-L/TR	0°C to 70°C	28-pin SSOP	Reel	Yes
SP3243EUCY-L/TR	0°C to 70°C	28-pin TSSOP	Reel	Yes
SP3243EUEA-L/TR	-40°C to 85°C	28-pin SSOP	Reel	Yes
SP3243EUEY-L/TR	-40°C to 85°C	28-pin TSSOP	Reel	Yes
SP3243EUER-L/TR	-40°C to 85°C	32-pin QFN	Reel	Yes

1. Refer to [www.maxlinear.com/SP3243E](http://www.maxlinear.com/SP3243E), [www.maxlinear.com/SP3243EB](http://www.maxlinear.com/SP3243EB), [www.maxlinear.com/SP3243EH](http://www.maxlinear.com/SP3243EH), [www.maxlinear.com/SP3243EU](http://www.maxlinear.com/SP3243EU) for most up-to-date Ordering Information.

2. Visit [www.maxlinear.com](http://www.maxlinear.com) for additional information on Environmental Rating.



**Figure 34: Part Nomenclature**



MaxLinear, Inc.  
 5966 La Place Court, Suite 100  
 Carlsbad, CA 92008  
 760.692.0711 p.  
 760.444.8598 f.  
[www.maxlinear.com](http://www.maxlinear.com)

The content of this document is furnished for informational use only, is subject to change without notice, and should not be construed as a commitment by MaxLinear, Inc. MaxLinear, Inc. assumes no responsibility or liability for any errors or inaccuracies that may appear in the informational content contained in this guide. Complying with all applicable copyright laws is the responsibility of the user. Without limiting the rights under copyright, no part of this document may be reproduced into, stored in, or introduced into a retrieval system, or transmitted in any form or by any means (electronic, mechanical, photocopying, recording, or otherwise), or for any purpose, without the express written permission of MaxLinear, Inc.

MaxLinear, Inc. does not recommend the use of any of its products in life support applications where the failure or malfunction of the product can reasonably be expected to cause failure of the life support system or to significantly affect its safety or effectiveness. Products are not authorized for use in such applications unless MaxLinear, Inc. receives, in writing, assurances to its satisfaction that: (a) the risk of injury or damage has been minimized; (b) the user assumes all such risks; (c) potential liability of MaxLinear, Inc. is adequately protected under the circumstances.

MaxLinear, Inc. may have patents, patent applications, trademarks, copyrights, or other intellectual property rights covering subject matter in this document. Except as expressly provided in any written license agreement from MaxLinear, Inc., the furnishing of this document does not give you any license to these patents, trademarks, copyrights, or other intellectual property.

MaxLinear, the MaxLinear logo, and any MaxLinear trademarks, MxL, Full-Spectrum Capture, FSC, G.now, AirPHY and the MaxLinear logo are all on the products sold, are all trademarks of MaxLinear, Inc. or one of MaxLinear's subsidiaries in the U.S.A. and other countries. All rights reserved. Other company trademarks and product names appearing herein are the property of their respective owners.

## Looking for pricing, stock, or lifecycle information?

Click below to explore more details on WIN SOURCE:

 [View SP3243EEA-L on WIN SOURCE](#)

 [Exar Corporation](#) Information

## Optimize Your Supply Chain with WIN SOURCE Solutions

-  Global Sourcing Solution
-  Obsolete Management
-  Cost Control Management
-  Shortage Management
-  Alternative Solution
-  Excess Inventory Management