



**THE DATASHEET OF  
SP3232EBEA-L/TR**





# SP3222EB/SP3232EB

## True +3.0V to +5.5V RS-232 Transceivers

### FEATURES

- Meets true EIA/TIA-232-F Standards from a +3.0V to +5.5V power supply
- 250kbps Transmission Rate Under Load
- 1 $\mu$ A Low Power Shutdown with Receivers active (**SP3222EB**)
- Interoperable with RS-232 down to a +2.7V power source
- Enhanced ESD Specifications:
  - $\pm$ 15kV Human Body Model
  - $\pm$ 15kV IEC61000-4-2 Air Discharge
  - $\pm$ 8kV IEC61000-4-2 Contact Discharge

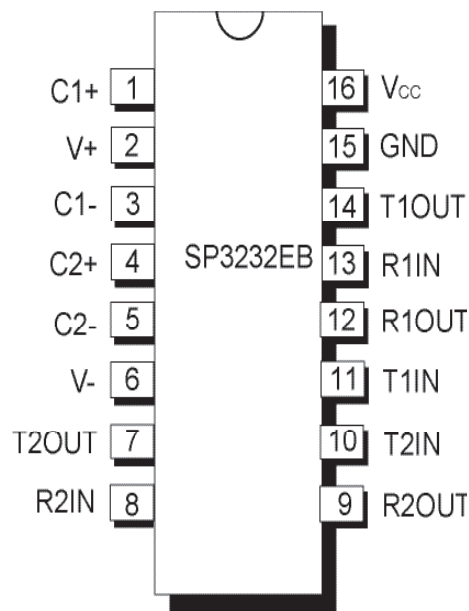

### DESCRIPTION

The SP3222EB/SP3232EB series is an RS-232 transceiver solution intended for portable or hand-held applications such as notebook or laptop computers. The SP3222EB/SP3232EB series has a high-efficiency, charge-pump power supply that requires only 0.1 $\mu$ F capacitors in 3.3V operation. This charge pump allows the SP3222EB/SP3232EB series to deliver true RS-232 performance from a single power supply ranging from +3.0V to +5.5V. The SP3222EB/SP3232EB are 2-driver/2-receiver devices. The ESD tolerance of the SP3222EB/SP3232EB devices is over  $\pm$ 15kV for both Human Body Model and IEC61000-4-2 Air discharge test methods. The SP3222EB device has a low-power shutdown mode where the devices' driver outputs and charge pumps are disabled. During shutdown, the supply current falls to less than 1 $\mu$ A.

### SELECTION TABLE

Device	Power Supplies	RS-232 Drivers	RS-232 Receivers	External Components	Shutdown	TTL 3-State	# of Pins
SP3222EB	+3.0V to +5.5V	2	2	4 Capacitors	Yes	Yes	18, 20
SP3232EB	+3.0V to +5.5V	2	2	4 Capacitors	No	No	16

## ABSOLUTE MAXIMUM RATINGS

These are stress ratings only and functional operation of the device at these ratings or any other above those indicated in the operation sections of the specifications below is not implied. Exposure to absolute maximum rating conditions for extended periods of time may affect reliability and cause permanent damage to the device.

V <sub>CC</sub> .....	-0.3V to +6.0V
V+ (NOTE 1).....	-0.3V to +7.0V
V- (NOTE 1).....	+0.3V to -7.0V
V+ +  V-  (NOTE 1).....	+13V
I <sub>CC</sub> (DC V <sub>CC</sub> or GND current).....	±100mA

### Input Voltages

TxIN, EN.....	-0.3V to +6.0V
RxIN.....	+25V

### Output Voltages

TxOUT.....	±13.2V
RxOUT, .....	-0.3V to (V <sub>CC</sub> +0.3V)

### Short-Circuit Duration

TxOUT.....	Continuous
Storage Temperature.....	-65°C to +150°C

### Power Dissipation per package

20-pin SSOP (derate 9.25mW/°C above +70°C).....	750mW
18-pin SOIC (derate 15.7mW/°C above +70°C).....	1260mW
20-pin TSSOP (derate 11.1mW/°C above +70°C).....	890mW
16-pin SSOP (derate 9.69mW/°C above +70°C).....	775mW
16-pin Wide SOIC (derate 11.2mW/°C above +70°C).....	900mW
16-pin TSSOP (derate 10.5mW/°C above +70°C).....	850mW
16-pin nSOIC (derate 13.57mW/°C above +70°C).....	1086mW

Maximum Junction Temperature .....	+125°C
Thermal Resistance (16-pin TSSOP) $\theta_{JA}$ .....	100.4°C/W
Thermal Resistance (16-pin TSSOP) $\theta_{JC}$ .....	19.0°C/W
Thermal Resistance (16-pin QFN) $\theta_{JA}$ .....	44.0°C/W
Thermal Resistance (16-pin QFN) $\theta_{JC}$ .....	7.3°C/W

**NOTE 1:** V+ and V- can have maximum magnitudes of 7V, but their absolute difference cannot exceed 13V.

**NOTE 2:** Driver Input hysteresis is typically 250mV.

## ELECTRICAL CHARACTERISTICS

Unless otherwise noted, the following specifications apply for V<sub>CC</sub> = +3.0V to +5.5V with T<sub>AMB</sub> = T<sub>MIN</sub> to T<sub>MAX</sub>, C1 - C4 = 0.1µF.

PARAMETER	MIN.	TYP.	MAX.	UNITS	CONDITIONS
<b>DC CHARACTERISTICS</b>					
Supply Current		0.3	1.0	mA	no load, V <sub>CC</sub> = 3.3V, T <sub>AMB</sub> = 25°C, TxIN = GND or V <sub>CC</sub>
Shutdown Supply Current		1.0	10	µA	$\overline{\text{SHDN}}$ = GND, V <sub>CC</sub> = 3.3V, T <sub>AMB</sub> = 25°C, TxIN = V <sub>CC</sub> or GND
<b>LOGIC INPUTS AND RECEIVER OUTPUTS</b>					
Input Logic Threshold LOW	GND		0.8	V	TxIN, $\overline{\text{EN}}$ , $\overline{\text{SHDN}}$ , Note 2
Input Logic Threshold HIGH	2.0		V <sub>CC</sub>	V	V <sub>CC</sub> = 3.3V, Note 2
Input Logic Threshold HIGH	2.4		V <sub>CC</sub>	V	V <sub>CC</sub> = 5.0V, Note 2
Input Leakage Current		±0.01	±1.0	µA	TxIN, $\overline{\text{EN}}$ , $\overline{\text{SHDN}}$ , T <sub>AMB</sub> = +25°C, V <sub>IN</sub> = 0V to V <sub>CC</sub>
Output Leakage Current		±0.05	±10	µA	Receivers disabled, V <sub>OUT</sub> = 0V to V <sub>CC</sub>
Output Voltage LOW			0.4	V	I <sub>OUT</sub> = 1.6mA
Output Voltage HIGH	V <sub>CC</sub> -0.6	V <sub>CC</sub> -0.1		V	I <sub>OUT</sub> = -1.0mA
<b>DRIVER OUTPUTS</b>					
Output Voltage Swing	±5.0	±5.4		V	All driver outputs loaded with 3kΩ to GND, T <sub>AMB</sub> = +25°C

## ELECTRICAL CHARACTERISTICS

Unless otherwise noted, the following specifications apply for  $V_{CC} = +3.0V$  to  $+5.5V$  with  $T_{AMB} = T_{MIN}$  to  $T_{MAX}$ ,  $C1 - C4 = 0.1\mu F$ . Typical values apply at  $V_{CC} = +3.3V$  or  $+5.0V$  and  $T_{AMB} = 25^{\circ}C$ .

PARAMETER	MIN.	TYP.	MAX.	UNITS	CONDITIONS
<b>DRIVER OUTPUTS (continued)</b>					
Output Resistance	300			$\Omega$	$V_{CC} = V+ = V- = 0V, V_{OUT} = \pm 2V$
Output Short-Circuit Current		$\pm 35$	$\pm 60$	mA	$V_{OUT} = 0V$
Output Leakage Current			$\pm 25$	$\mu A$	$V_{CC} = 0V$ or $3.0V$ to $5.5V, V_{OUT} = \pm 12V$ , Drivers disabled
<b>RECEIVER INPUTS</b>					
Input Voltage Range	-15		15	V	
Input Threshold LOW	0.6	1.2		V	$V_{CC} = 3.3V$
Input Threshold LOW	0.8	1.5		V	$V_{CC} = 5.0V$
Input Threshold HIGH		1.5	2.4	V	$V_{CC} = 3.3V$
Input Threshold HIGH		1.8	2.4	V	$V_{CC} = 5.0V$
Input Hysteresis		0.3		V	
Input Resistance	3	5	7	k $\Omega$	
<b>TIMING CHARACTERISTICS</b>					
Maximum Data Rate	250			kbps	$R_L = 3k\Omega, C_L = 1000pF$ , one driver active
Receiver Propagation Delay, $t_{PHL}$		0.15		$\mu s$	Receiver input to Receiver output, $C_L = 150pF$
Receiver Propagation Delay, $t_{PLH}$		0.15		$\mu s$	Receiver input to Receiver output, $C_L = 150pF$
Receiver Output Enable Time		200		ns	
Receiver Output Disable Time		200		ns	
Driver Skew		100		ns	$ t_{PHL} - t_{PLH} , T_{AMB} = 25^{\circ}C$
Receiver Skew		50		ns	$ t_{PHL} - t_{PLH} $
Transition-Region Slew Rate			30	V/ $\mu s$	$V_{CC} = 3.3V, R_L = 3k\Omega, C_L = 1000pF, T_{AMB} = 25^{\circ}C$ , measurements taken from $-3.0V$ to $+3.0V$ or $+3.0V$ to $-3.0V$

## TYPICAL PERFORMANCE CHARACTERISTICS

Unless otherwise noted, the following performance characteristics apply for  $V_{CC} = +3.3V$ , 1000kbps data rate, all drivers loaded with 3k $\Omega$ , 0.1 $\mu F$  charge pump capacitors, and  $T_{AMB} = +25^{\circ}C$ .

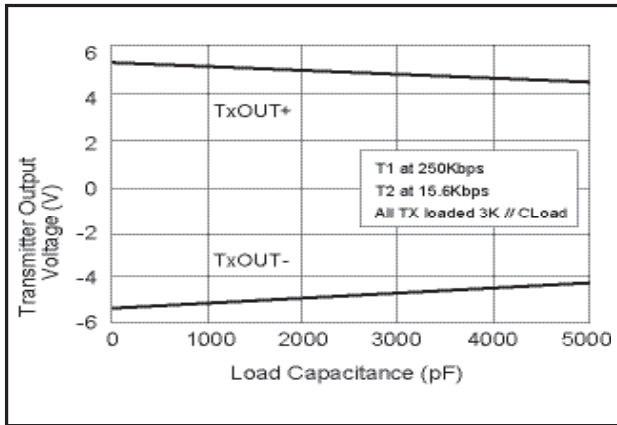

Figure 1. Transmitter Output Voltage vs Load Capacitance

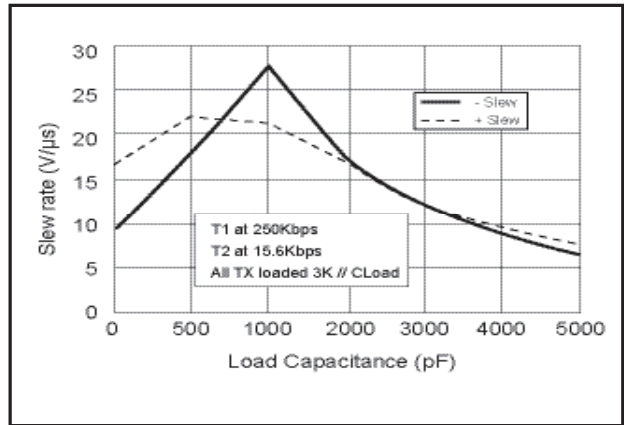

Figure 2. Slew Rate vs Load Capacitance

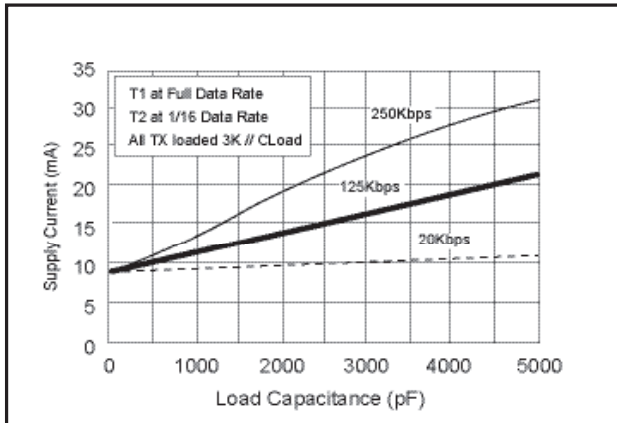

Figure 3. Supply Current VS. Load Capacitance when Transmitting Data

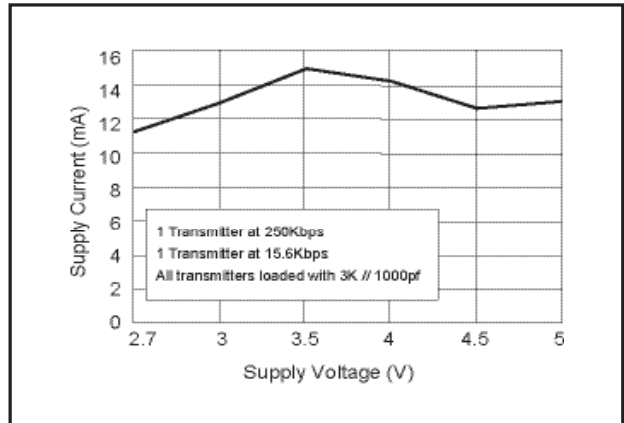

Figure 4. Supply Current VS. Supply Voltage

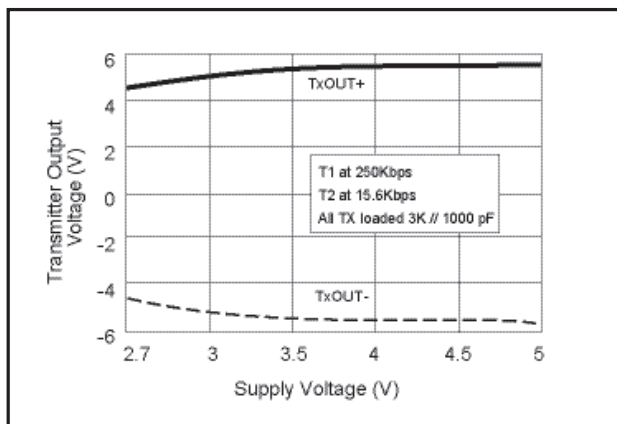

Figure 5. Transmitter Output Voltage vs Supply Voltage

NAME	FUNCTION	PIN NUMBER			
		SP3222EB		SP3232EB	
		SOIC	SSOP TSSOP	SSOP TSSOP NSOIC WSOIC	QFN
$\overline{\text{EN}}$	Receiver Enable. Apply Logic LOW for normal operation. Apply logic HIGH to disable the receiver outputs (high-Z state)	1	1	-	-
C1+	Positive terminal of the voltage doubler charge-pump capacitor	2	2	1	15
V+	+5.5V output generated by the charge pump	3	3	2	16
C1-	Negative terminal of the voltage doubler charge-pump capacitor	4	4	3	1
C2+	Positive terminal of the inverting charge-pump capacitor	5	5	4	2
C2-	Negative terminal of the inverting charge-pump capacitor	6	6	5	3
V-	-5.5V output generated by the charge pump	7	7	6	4
T <sub>1</sub> OUT	RS-232 driver output.	15	17	14	12
T <sub>2</sub> OUT	RS-232 driver output.	8	8	7	5
R <sub>1</sub> IN	RS-232 receiver input	14	16	13	11
R <sub>2</sub> IN	RS-232 receiver input	9	9	8	6
R <sub>1</sub> OUT	TTL/CMOS receiver output	13	15	12	10
R <sub>2</sub> OUT	TTL/CMOS receiver output	10	10	9	7
T <sub>1</sub> IN	TTL/CMOS driver input	12	13	11	9
T <sub>2</sub> IN	TTL/CMOS driver input	11	12	10	8
GND	Ground.	16	18	15	13
V <sub>CC</sub>	+3.0V to +5.5V supply voltage	17	19	16	14
$\overline{\text{SHDN}}$	Shutdown Control Input. Drive HIGH for normal device operation. Drive LOW to shutdown the drivers (high-Z output) and the on-board power supply	18	20	-	-
N.C.	No Connect	-	11, 14	-	-

Table 1. Device Pin Description

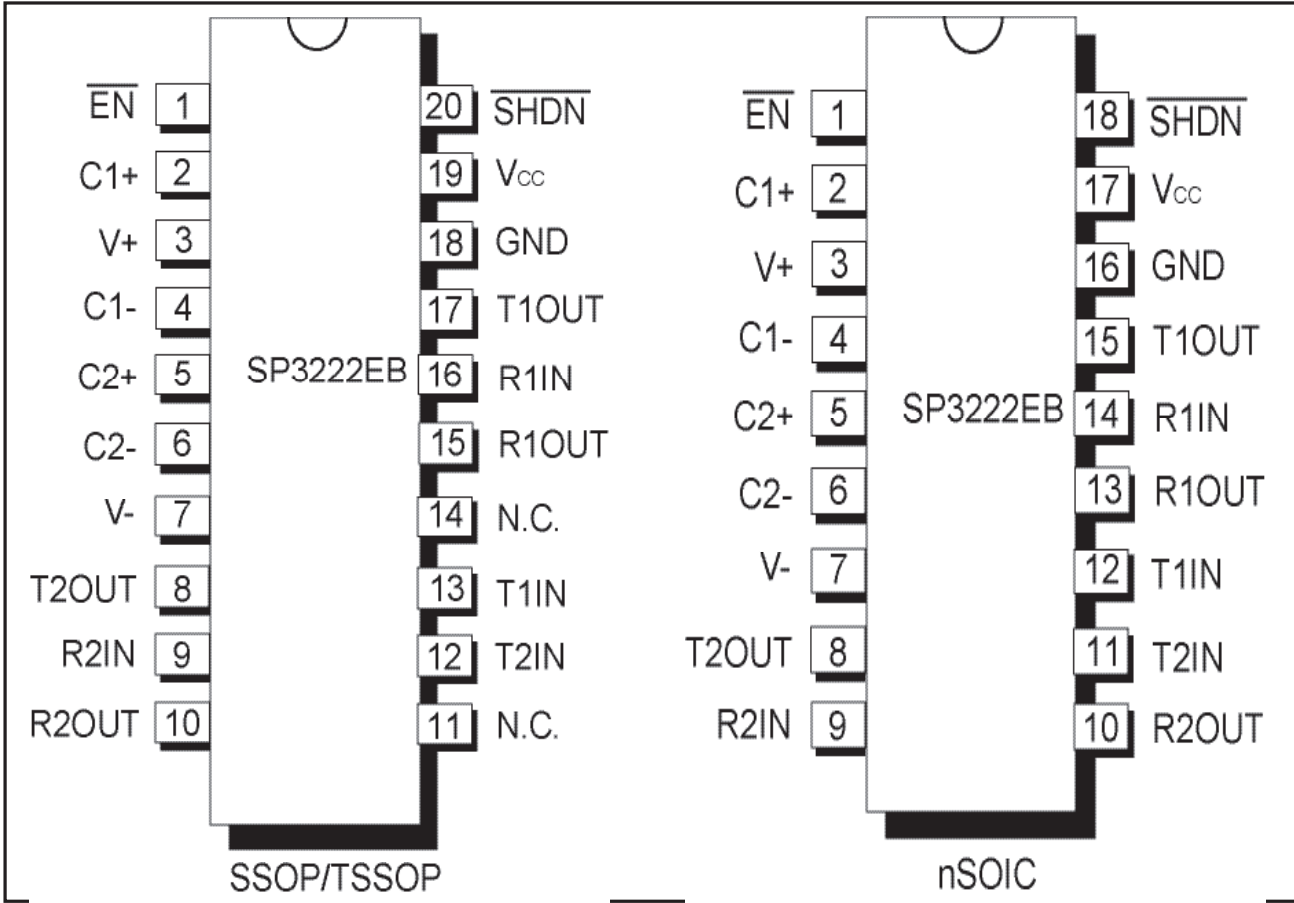

Figure 6. Pinout Configurations for the SP3222EB

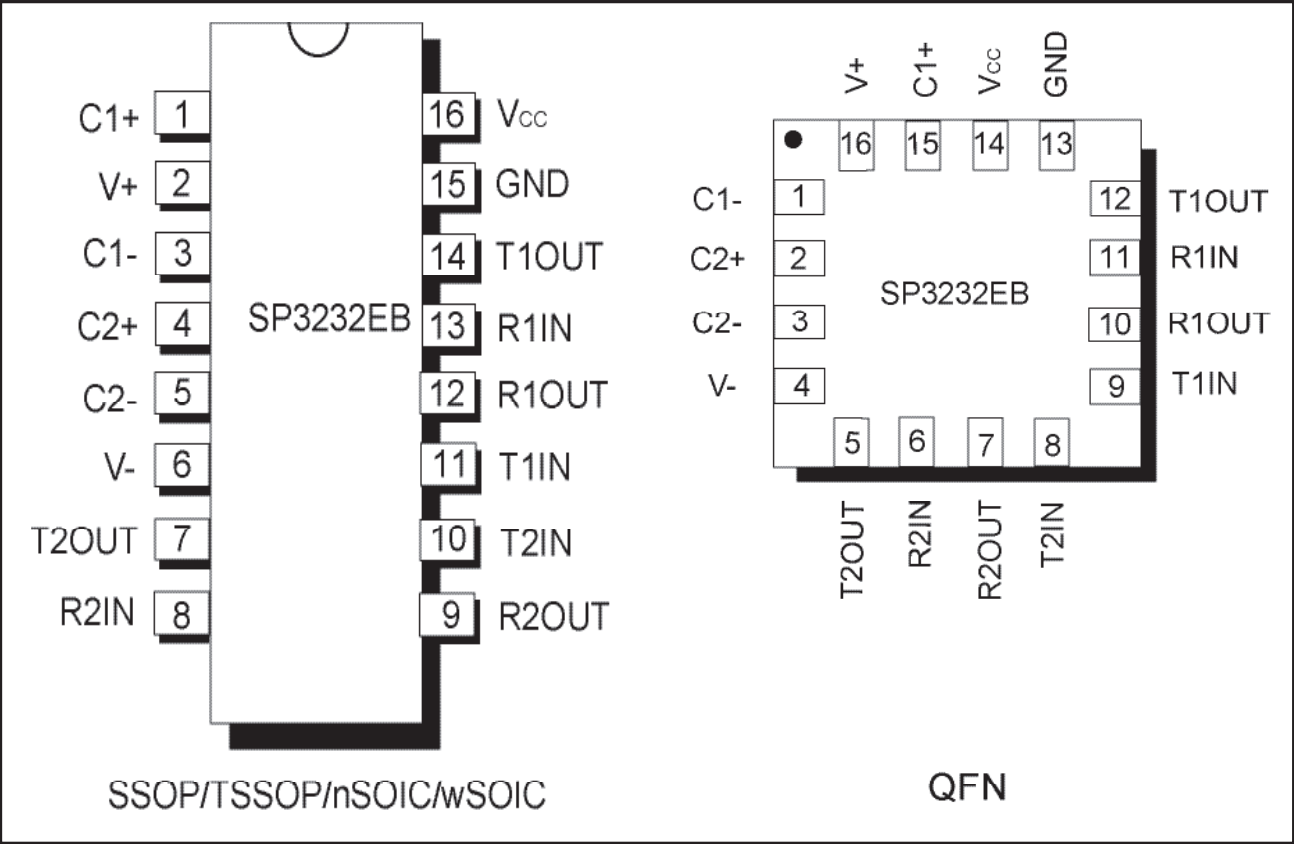

Figure 7. Pinout Configuration for the SP3232EB

# TYPICAL OPERATING CIRCUITS

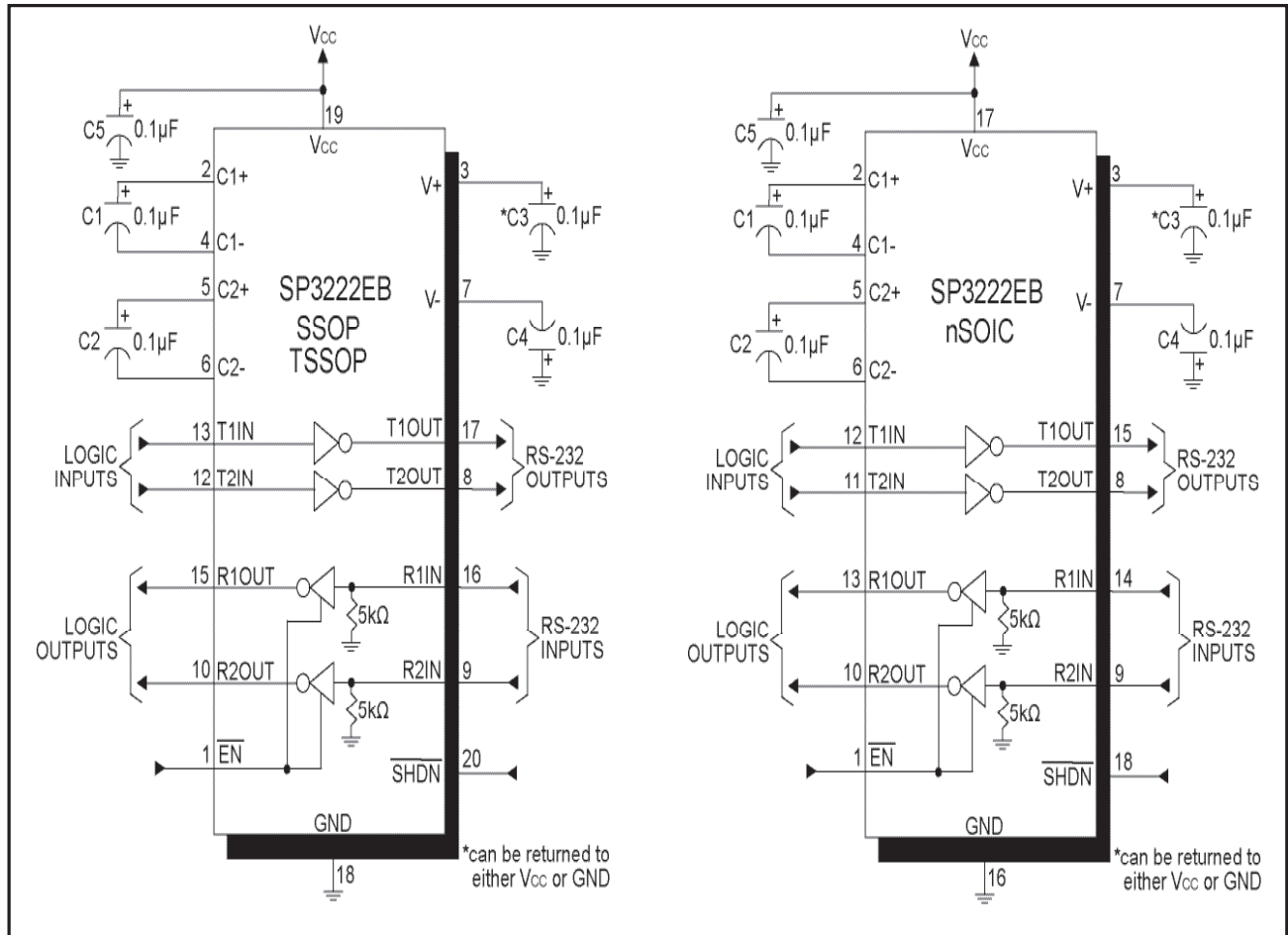

Figure 8. SP3222EB Typical Operating Circuits

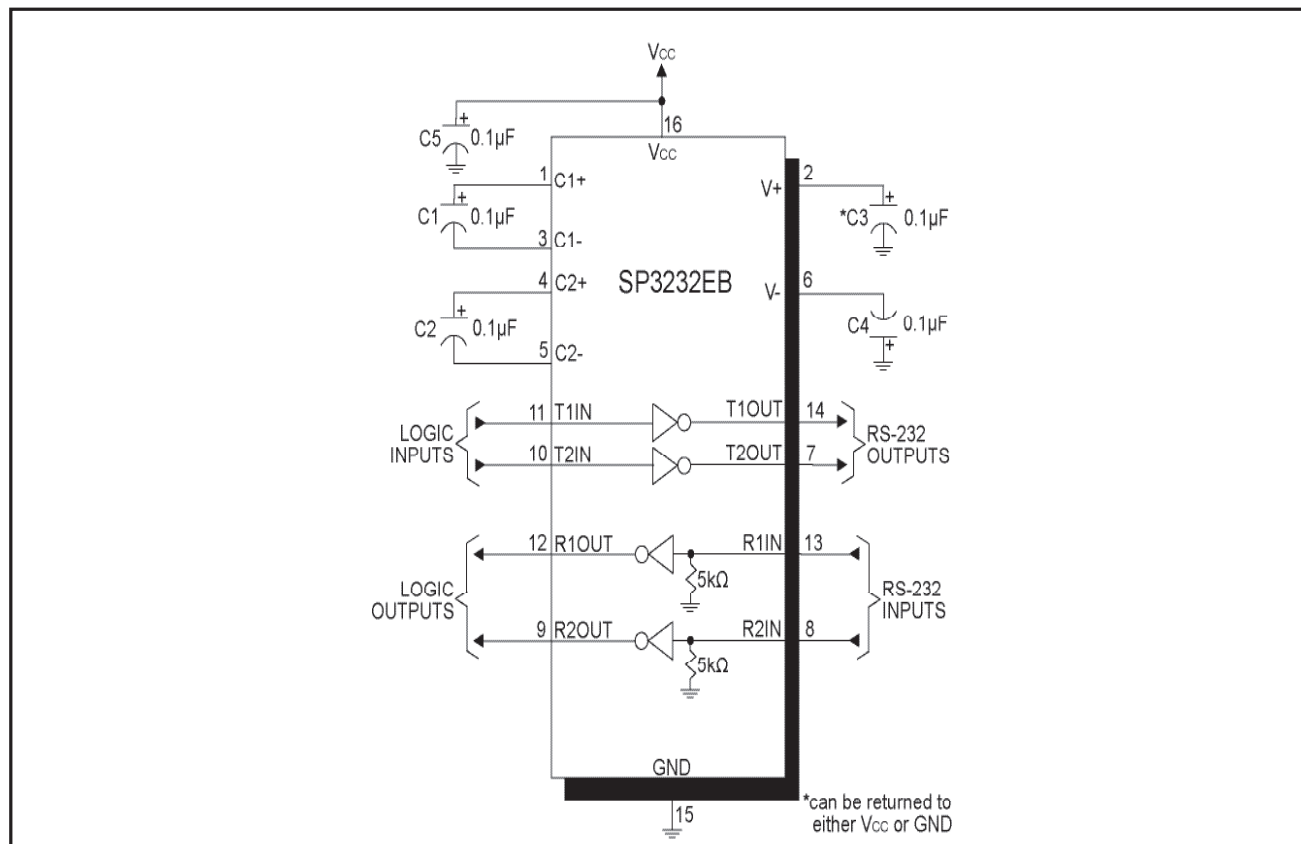

Figure 9. SP3232EB Typical Operating Circuit

The **SP3222EB/SP3232EB** transceivers meet the EIA/TIA-232 and ITU-T V.28/V.24 communication protocols and can be implemented in battery-powered, portable, or hand-held applications such as notebook or palmtop computers. The **SP3222EB/SP3232EB** devices feature Exar's proprietary on-board charge pump circuitry that generates  $\pm 5.5V$  for RS-232 voltage levels from a single  $+3.0V$  to  $+5.5V$  power supply. This series is ideal for  $+3.3V$ -only systems, mixed  $+3.3V$  to  $+5.5V$  systems, or  $+5.0V$ -only systems that require true RS-232 performance. The **SP3222EB/SP3232EB** devices can operate at a data rate of 250kbps when fully loaded.

The **SP3222EB** and **SP3232EB** are 2-driver/2-receiver devices ideal for portable or hand-held applications. The **SP3222EB** features a  $1\mu A$  shutdown mode that reduces power consumption and extends battery life in portable systems. Its receivers remain active in shutdown mode, allowing external devices such as modems to be monitored using only  $1\mu A$  supply current.

## THEORY OF OPERATION

The **SP3222EB/SP3232EB** series is made up of three basic circuit blocks:

1. Drivers
2. Receivers
3. The Exar proprietary charge pump

### Drivers

The drivers are inverting level transmitters that convert TTL or CMOS logic levels to  $\pm 5.0V$  EIA/TIA-232 levels with an inverted sense relative to the input logic levels. Typically, the RS-232 output voltage swing is  $\pm 5.4V$  with no load and  $\pm 5V$  minimum fully loaded. The driver outputs are protected against infinite short-circuits to ground without degradation in reliability. Driver outputs will meet EIA/TIA-562 levels of  $\pm 3.7V$  with supply voltages as low as  $2.7V$ .

The drivers can guarantee a data rate of 250kbps fully loaded with  $3k\Omega$  in parallel with  $1000pF$ , ensuring compatibility with PC-to-PC communication software.

The slew rate of the driver is internally limited to a maximum of  $30V/\mu s$  in order to meet the EIA standards (EIA RS-232D 2.1.7, Paragraph 5). The transition of the loaded output from HIGH to LOW also meet the monotonicity requirements of the standard.

Figure 10 shows a loopback test circuit used to test the RS-232 Drivers. Figure 11 shows the test results of the loopback circuit with all drivers active at 120kbps with RS-232 loads in parallel with a  $1000pF$  capacitor. Figure 12 shows the test results where one driver was active at 250kbps and all drivers loaded with an RS-232 receiver in parallel with  $1000pF$  capacitors. A solid RS-232 data transmission rate of 250kbps provides compatibility with many designs in personal computer peripherals and LAN applications.

The **SP3222EB** driver's output stages are turned off (tri-state) when the device is in shutdown mode. When the power is off, the **SP3222EB** device permits the outputs to be driven up to  $\pm 12V$ . The driver's inputs do not have pull-up resistors. Designers should connect unused inputs to  $V_{CC}$  or GND.

In the shutdown mode, the supply current falls to less than  $1\mu A$ , where  $\overline{SHDN} = \text{LOW}$ . When the **SP3222EB** device is shut down, the device's driver outputs are disabled (tri-stated) and the charge pumps are turned off with  $V+$  pulled down to  $V_{CC}$  and  $V-$  pulled to GND. The time required to exit shutdown is typically  $100\mu s$ . Connect  $\overline{SHDN}$  to  $V_{CC}$  if the shutdown mode is not used.

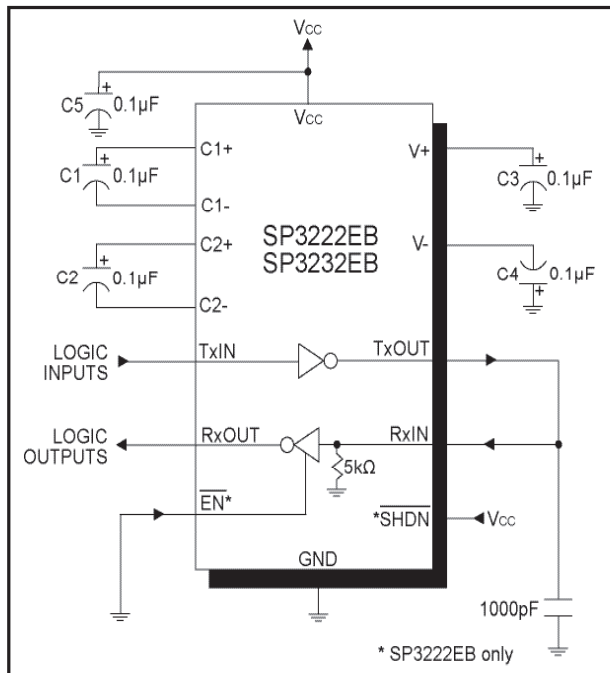

Figure 10. SP3222EB/SP3232EB Driver Loopback Test Circuit

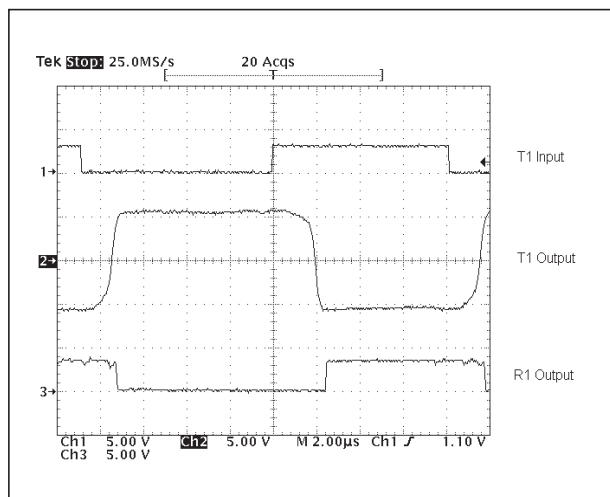

Figure 11. Loopback Test results at 120kbps

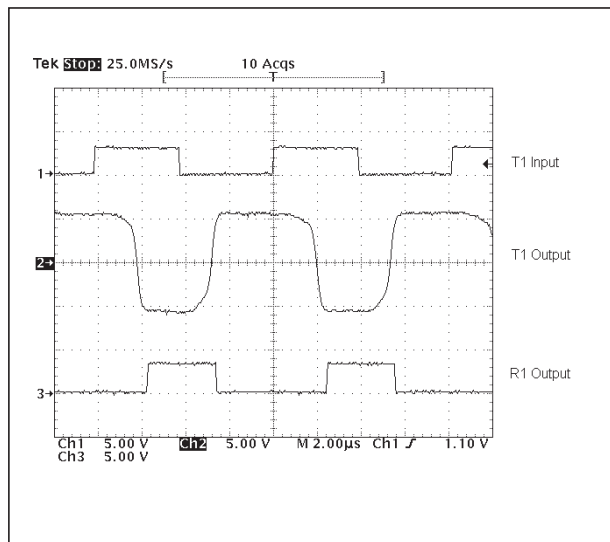

Figure 12. Loopback Test results at 250kbps

## Receivers

The Receivers convert EIA/TIA-232 levels to TTL or CMOS logic output levels. The **SP3222EB** receivers have an inverting tri-state output. These receiver outputs (RxOUT) are tri-stated when the enable control EN = HIGH. In the shutdown mode, the receivers can be active or inactive. EN has no effect on TxOUT. The truth table logic of the **SP3222EB** driver and receiver outputs can be found in Table 2.

<u>SHDN</u>	<u>EN</u>	TxOUT	RxOUT
0	0	Tri-state	Active
0	1	Tri-state	Tri-state
1	0	Active	Active
1	1	Active	Tri-state

Table 2. SP3222EB Truth Table Logic for Shutdown and Enable Control

Since receiver input is usually from a transmission line where long cable lengths and system interference can degrade the signal, the inputs have a typical hysteresis margin of 300mV. This ensures that the receiver is virtually immune to noisy transmission lines. Should an input be left unconnected, an internal 5kΩ pull-down resistor to ground will commit the output of the receiver to a HIGH state.

## Charge Pump

The charge pump is an Exar-patented design (U.S. 5,306,954) and uses a unique approach compared to older less-efficient designs. The charge pump still requires four external capacitors, but uses a four-phase voltage shifting technique to attain symmetrical 5.5V power supplies. The internal power supply consists of a regulated dual charge pump that provides output voltages of +/-5.5V regardless of the input voltage (Vcc) over the +3.0V to +5.5V range.

In most circumstances, decoupling the power supply can be achieved adequately using a 0.1 $\mu$ F bypass capacitor at C5 (refer to figures 8 and 9)

In applications that are sensitive to power-supply noise, decouple Vcc to ground with a capacitor of the same value as charge-pump capacitor C1. Physically connect bypass capacitors as close to the IC as possible.

The charge pump operates in a discontinuous mode using an internal oscillator. If the output voltages are less than a magnitude of 5.5V, the charge pump is enabled. If the output voltages exceed a magnitude of 5.5V, the charge pump is disabled. This oscillator controls the four phases of the voltage shifting. A description of each phase follows.

#### Phase 1

—  $V_{SS}$  charge storage — During this phase of the clock cycle, the positive side of capacitors  $C_1$  and  $C_2$  are initially charged to  $V_{CC}$ .  $C_1^+$  is then switched to GND and the charge in  $C_1^-$  is transferred to  $C_2^-$ . Since  $C_2^+$  is connected to  $V_{CC}$ , the voltage potential across capacitor  $C_2$  is now 2 times  $V_{CC}$ .

#### Phase 2

—  $V_{SS}$  transfer — Phase two of the clock connects the negative terminal of  $C_2$  to the  $V_{SS}$  storage capacitor and the positive terminal of  $C_2$  to GND. This transfers a negative generated voltage to  $C_3$ . This generated voltage is regulated to a minimum voltage of -5.5V. Simultaneous with the transfer of the voltage to  $C_3$ , the positive side of capacitor  $C_1$  is switched to  $V_{CC}$  and the negative side is connected to GND.

#### Phase 3

—  $V_{DD}$  charge storage — The third phase of the clock is identical to the first phase — the charge transferred in  $C_1$  produces  $-V_{CC}$  in the negative terminal of  $C_1$ , which is applied to the negative side of capacitor  $C_2$ . Since  $C_2^+$  is at  $V_{CC}$ , the voltage potential across  $C_2$  is 2 times  $V_{CC}$ .

#### Phase 4

—  $V_{DD}$  transfer — The fourth phase of the clock connects the negative terminal of  $C_2$  to GND, and transfers this positive generated voltage across  $C_2$  to  $C_4$ , the  $V_{DD}$  storage capacitor. This voltage is regulated to +5.5V. At this voltage, the internal oscillator is disabled. Simultaneous with the transfer of the voltage to  $C_4$ , the positive side of capacitor  $C_1$  is switched to  $V_{CC}$  and the negative side is connected to GND, allowing the charge pump cycle to begin again. The charge pump cycle will continue as long as the operational conditions for the internal oscillator are present.

Since both  $V^+$  and  $V^-$  are separately generated from  $V_{CC}$ , in a no-load condition  $V^+$  and  $V^-$  will be symmetrical. Older charge pump approaches that generate  $V^-$  from  $V^+$  will show a decrease in the magnitude of  $V^-$  compared to  $V^+$  due to the inherent inefficiencies in the design.

The clock rate for the charge pump typically operates at greater than 250kHz. The external capacitors can be as low as 0.1 $\mu$ F with a 16V breakdown voltage rating.

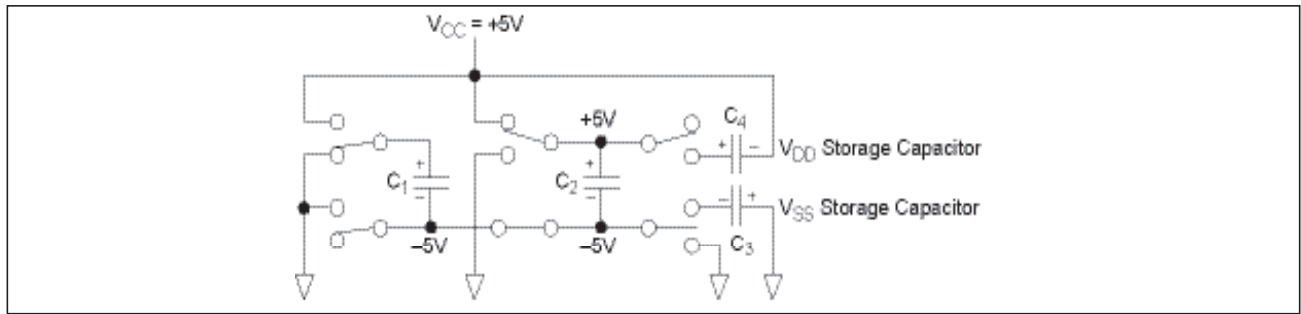

Figure 13. Charge Pump — Phase 1

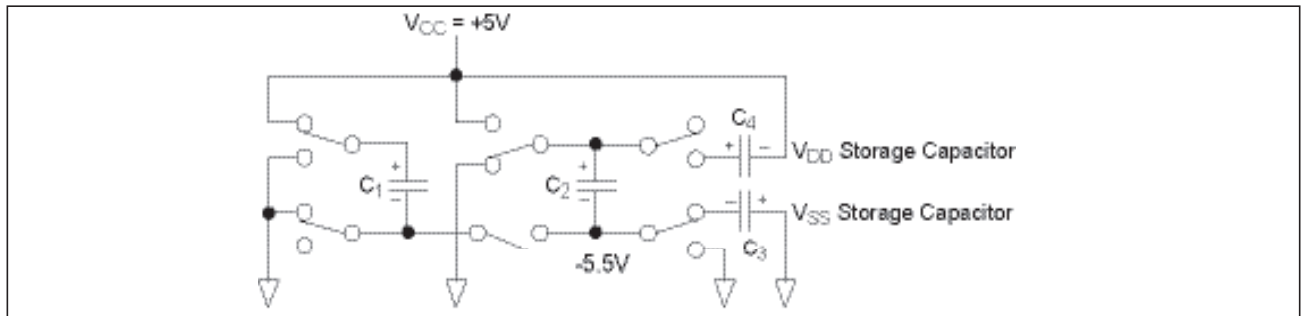

Figure 14. Charge Pump — Phase 2

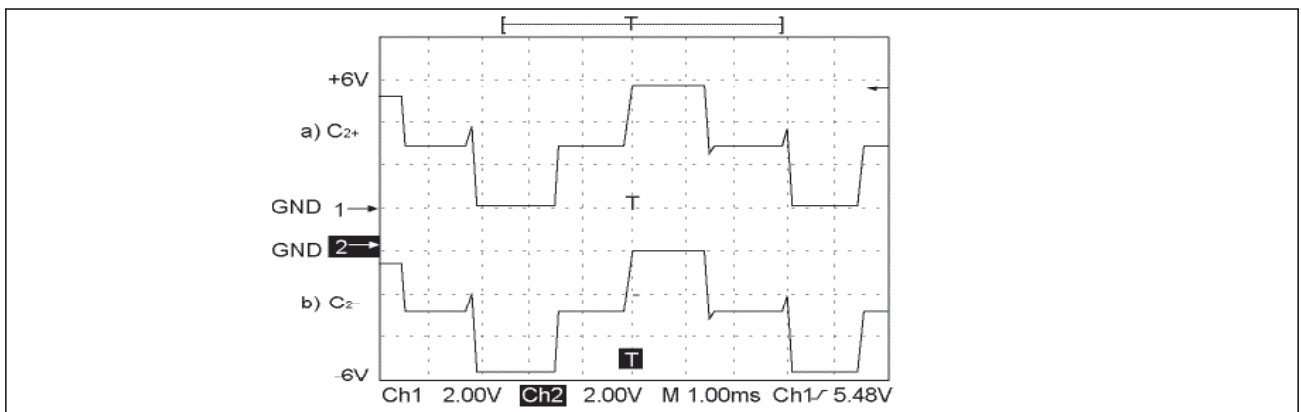

Figure 15. Charge Pump Waveforms

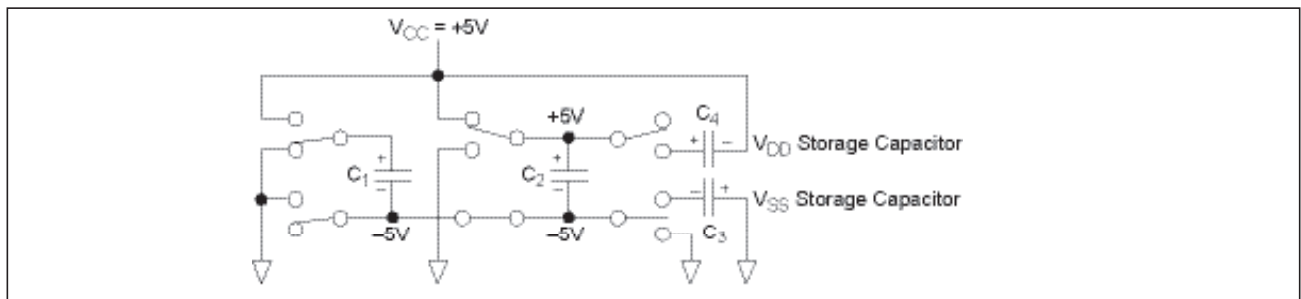

Figure 16. Charge Pump — Phase 3

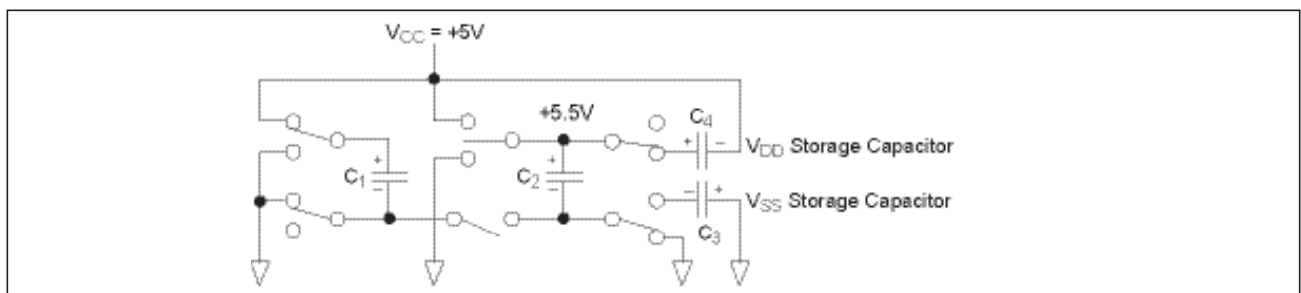

Figure 17. Charge Pump — Phase 4

## ESD TOLERANCE

The **SP3222EB/SP3232EB** series incorporates ruggedized ESD cells on all driver output and receiver input pins. The ESD structure is improved over our previous family for more rugged applications and environments sensitive to electro-static discharges and associated transients. The improved ESD tolerance is at least  $\pm 15\text{kV}$  without damage nor latch-up.

There are different methods of ESD testing applied:

- a) MIL-STD-883, Method 3015.7
- b) IEC61000-4-2 Air-Discharge
- c) IEC61000-4-2 Direct Contact

The Human Body Model has been the generally accepted ESD testing method for semi-conductors. This method is also specified in MIL-STD-883, Method 3015.7 for ESD testing. The premise of this ESD test is to simulate the human body's potential to store electro-static energy and discharge it to an integrated circuit. The simulation is performed by using a test model as shown in Figure 18. This method will test the IC's capability to withstand an ESD transient during normal handling such as in manufacturing areas where the ICs tend to be handled frequently.

The IEC-61000-4-2, formerly IEC801-2, is generally used for testing ESD on equipment and systems. For system manufacturers, they must guarantee a certain amount of ESD protection since the system itself is exposed to the outside environment and human presence. The premise with IEC61000-4-2 is that

the system is required to withstand an amount of static electricity when ESD is applied to points and surfaces of the equipment that are accessible to personnel during normal usage. The transceiver IC receives most of the ESD current when the ESD source is applied to the connector pins. The test circuit for IEC61000-4-2 is shown on Figure 19. There are two methods within IEC61000-4-2, the Air Discharge method and the Contact Discharge method.

With the Air Discharge Method, an ESD voltage is applied to the equipment under test (EUT) through air. This simulates an electrically charged person ready to connect a cable onto the rear of the system only to find an unpleasant zap just before the person touches the back panel. The high energy potential on the person discharges through an arcing path to the rear panel of the system before he or she even touches the system. This energy, whether discharged directly or through air, is predominantly a function of the discharge current rather than the discharge voltage. Variables with an air discharge such as approach speed of the object carrying the ESD potential to the system and humidity will tend to change the discharge current. For example, the rise time of the discharge current varies with the approach speed.

The Contact Discharge Method applies the ESD current directly to the EUT. This method was devised to reduce the unpredictability of the ESD arc. The discharge current rise time is constant since the energy is directly transferred without the air-gap arc. In situations such as hand held systems, the ESD charge can be directly discharged to the

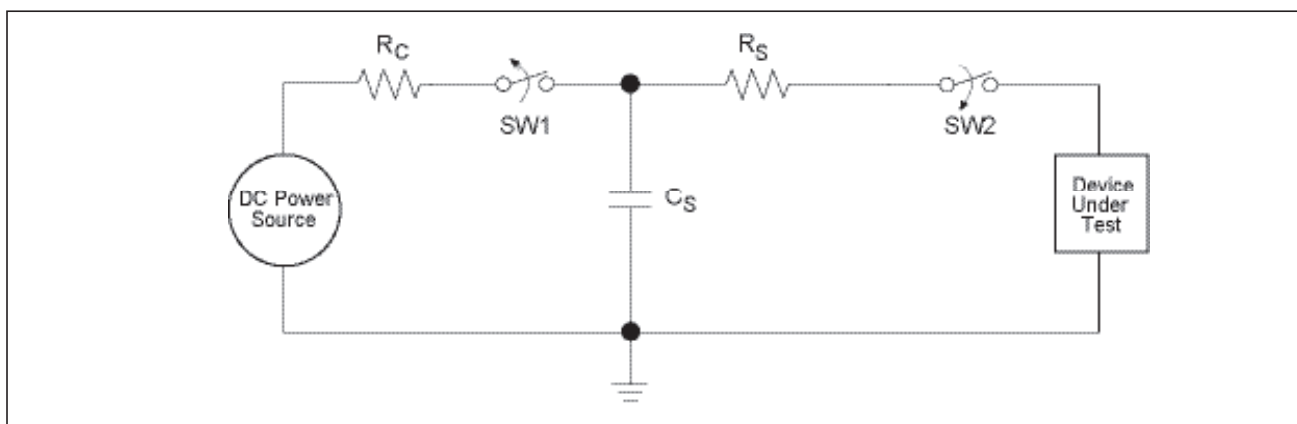

Figure 18. ESD Test Circuit for Human Body Model

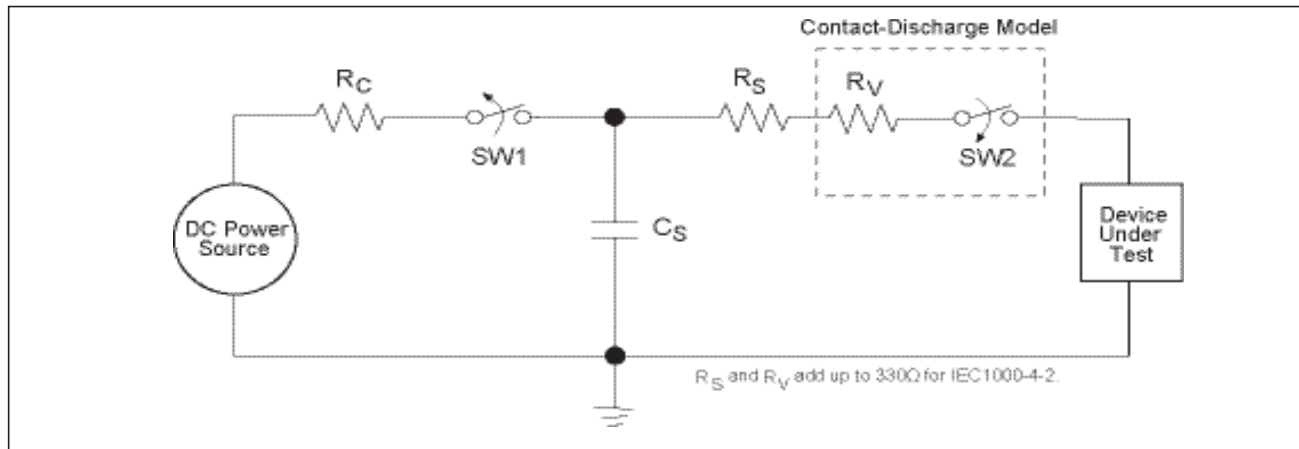

Figure 19. ESD Test Circuit for IEC61000-4-2

equipment from a person already holding the equipment. The current is transferred on to the keypad or the serial port of the equipment directly and then travels through the PCB and finally to the IC.

The circuit models in Figures 18 and 19 represent the typical ESD testing circuit used for all three methods. The  $C_S$  is initially charged with the DC power supply when the first switch (SW1) is on. Now that the capacitor is charged, the second switch (SW2) is on while SW1 switches off. The voltage stored in the capacitor is then applied through  $R_S$ , the current limiting resistor, onto the device under test (DUT). In ESD tests, the SW2 switch is pulsed so that the device under test receives a duration of voltage.

For the Human Body Model, the current limiting resistor ( $R_S$ ) and the source capacitor ( $C_S$ ) are 1.5k $\Omega$  and 100pF, respectively. For IEC-61000-4-2, the current limiting resistor ( $R_S$ ) and the source capacitor ( $C_S$ ) are 330 $\Omega$  and 150pF, respectively.

The higher  $C_S$  value and lower  $R_S$  value in the IEC61000-4-2 model are more stringent than the Human Body Model. The larger storage capacitor injects a higher voltage to the test point when SW2 is switched on. The lower current limiting resistor increases the current charge onto the test point.

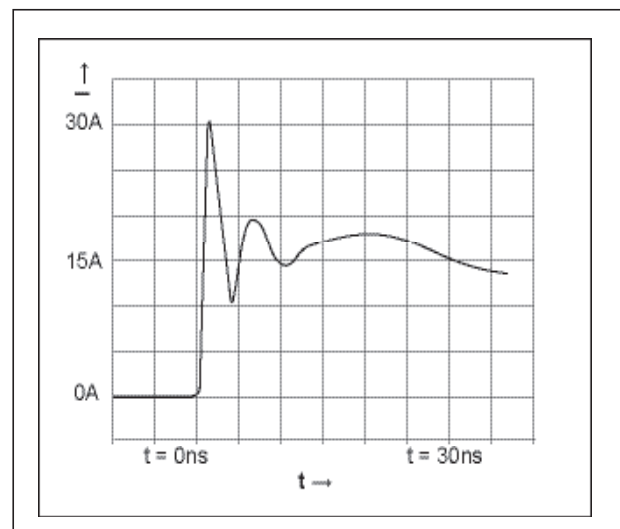
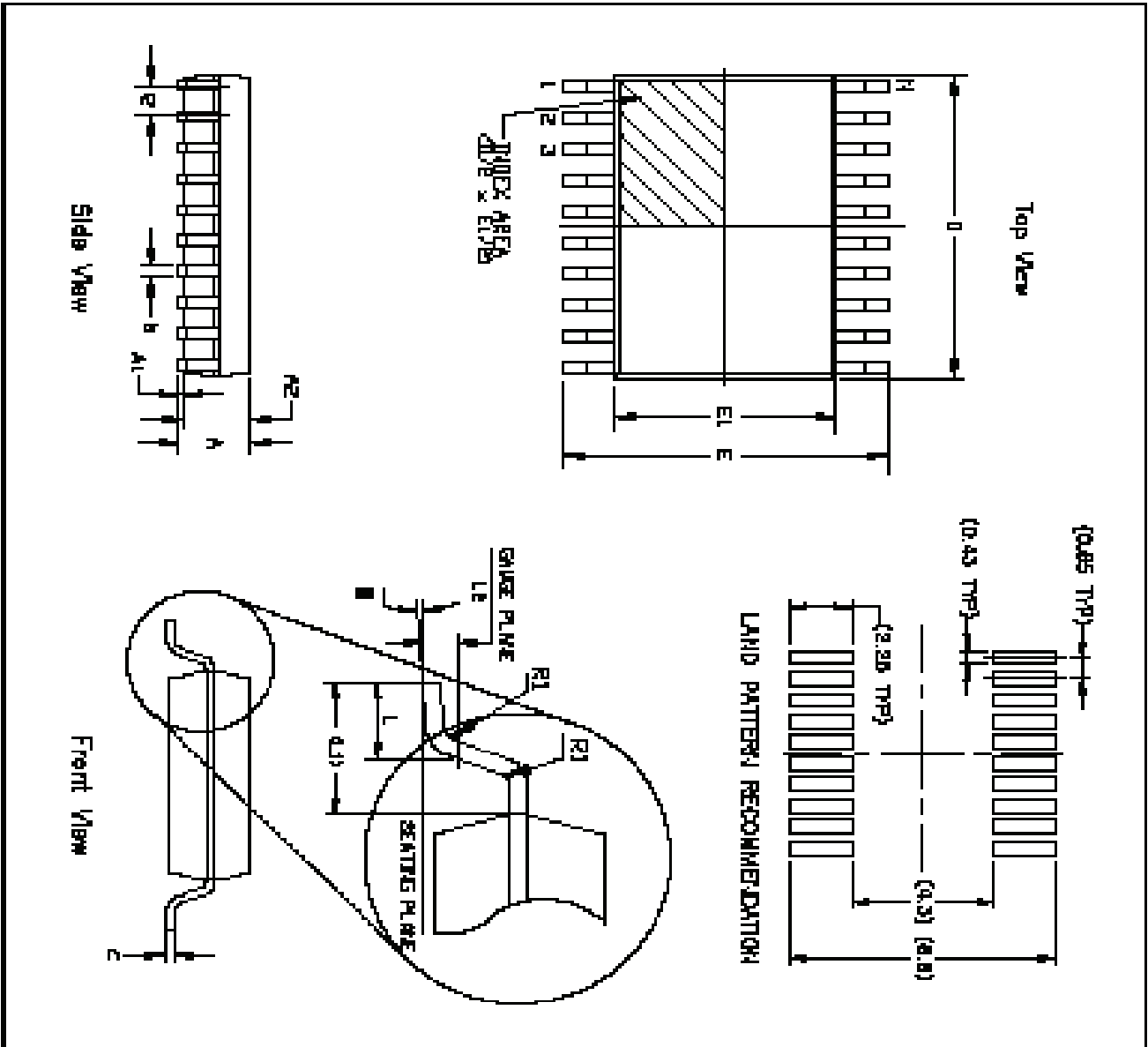

Figure 20. ESD Test Waveform for IEC61000-4-2

DEVICE PIN TESTED	HUMAN BODY MODEL	IEC61000-4-2		
		Air Discharge	Direct Contact	Level
Driver Outputs	$\pm 15\text{kV}$	$\pm 15\text{kV}$	$\pm 8\text{kV}$	4
Receiver Inputs	$\pm 15\text{kV}$	$\pm 15\text{kV}$	$\pm 8\text{kV}$	4

Table 3. Transceiver ESD Tolerance Levels



PINNING SYSTEM			
REF	DESCRIPTION	REF	APPRO
A	MINIMUM DIMENSIONS	0.00/0.00	A
B	REF. LAND PATTERN RECOMMENDATION	0.45/0.60	A
D	MINIMUM DIMENSIONS LEAD AND SEATING PLANE	1.00/0.75	A

20 PIN SSOP 450°C W/0-150 Variation PE										
DIMENSIONS IN UM		DIMENSIONS IN UM		DIMENSIONS IN UM		DIMENSIONS IN UM		DIMENSIONS IN UM		
(COMMON UNITS)										
SYMBOLS	MIN	TYP	MAX	MIN	MAX	MIN	MAX	MIN	MAX	
A	—	—	500	—	—	—	—	—	—	
A1	0.05	—	—	0.015	—	—	—	—	—	
A2	1.19	1.79	1.49	0.415	0.400	0.473	0.473	—	—	
b	0.22	—	0.20	0.008	—	0.010	—	—	—	
D	0.00	—	0.25	0.004	—	0.010	—	—	—	
E	7.40	7.40	8.59	0.290	0.307	0.323	—	—	—	
E1	3.40	3.50	4.00	0.137	0.200	0.220	—	—	—	
F	0.03	0.02	—	0.004	0.004	—	—	—	—	
L	0.55	0.25	0.45	0.024	0.030	0.037	—	—	—	
L1	1.20 REF		0.448 REF		—		—		—	
L2	0.25 REF		0.010 REF		—		—		—	
R1	0.00	—	—	0.004	—	—	—	—	—	
W	0	0	0	0	0	0	0	0	0	
D	8.00	7.20	7.20	0.272	0.263	0.263	—	—	—	
H	20		20		20		20		20	

**EXAR CORPORATION**

Package Approval: 11/01/07

Drawing No.: 20-PIN SSOP

Revision: 0

Sheet: 1 of 1

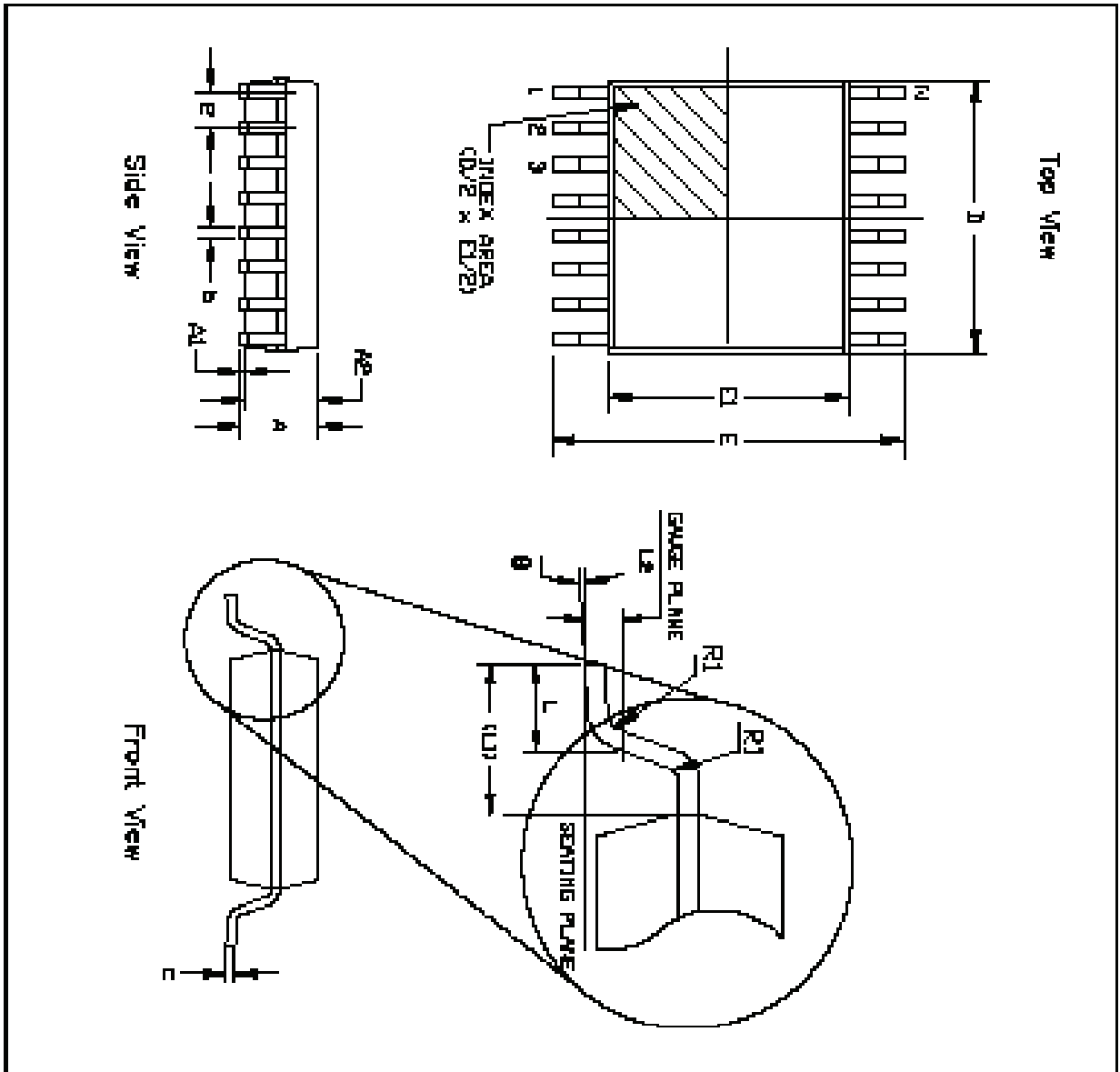

PINNOUT			
REF	DESCRIPTION	REF	NOTE
A	POWER SUPPLY	MAX 5V	1
B	DATA INPUT	MAX 5V	1

16 Pin SSOP JEDEC NID-150 Variation AC								
SYMBOLS	DIMENSIONS IN MM (CONFORM UNITS)		DIMENSIONS IN INCH (REFERENCE UNITS)		MIN		MAX	
	MIN	TYP	MIN	TYP	MIN	MAX	MIN	MAX
A	—	—	2.00	—	—	—	0.078	—
A1	0.65	—	—	0.026	—	—	—	—
A2	1.50	1.75	1.95	0.060	0.069	0.075	—	
B	0.92	—	0.36	0.009	—	0.015	—	
C	0.48	—	0.20	0.004	—	0.010	—	
E	7.40	7.60	0.29	0.291	0.207	0.263	—	
E1	0.60	0.30	0.06	0.117	0.204	0.280	—	
F	—	0.65 BSC	—	—	0.025 BSC	—	—	
L	0.00	0.75	0.00	0.022	0.000	0.007	—	
L1	—	1.20 REF	—	—	0.048 REF	—	—	
L2	—	0.20 BSC	—	—	0.010 BSC	—	—	
R1	0.08	—	—	0.004	—	—	—	
R2	0°	4°	0°	0°	4°	0°	—	
D	0.90	4.20	0.00	0.252	0.244	0.266	—	
U	—	16	—	—	16	—	—	

		<b>EXAR CORPORATION</b>	
Packaging Approval:		Drawing No: 16-PIN SSOP	
Date: 11/20/07		Revision: B Sheet: 1 of 1	

PINNING SCHEMATIC			
REF	DESCRIPTION	SIZE	APPROX
A	INSULATED PIN HEAD	1.40x0.50	4
B	INSULATED PIN HEAD DIAMETER	0.475x0.475	4
D	INSULATED PIN HEAD PIN SPACING (PITCH)	1.25x0.75	4

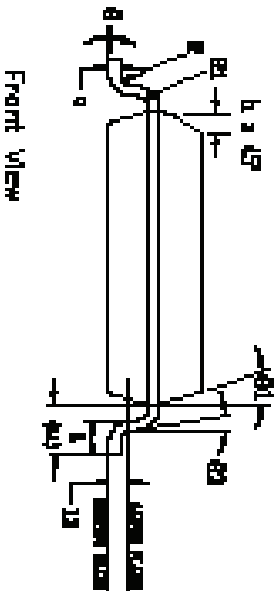
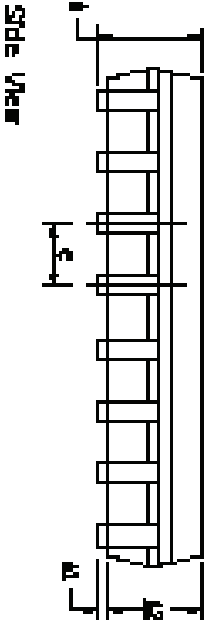
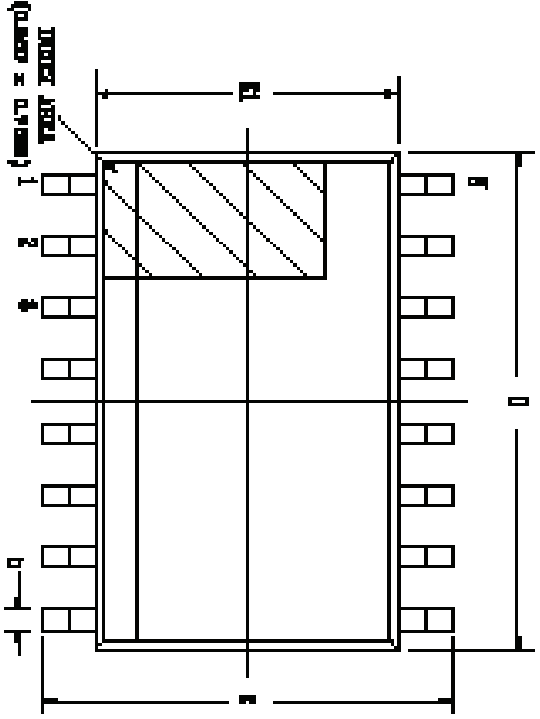

16 PIN SOICW INDEX MS-Q13 Variation A4			
SYMBOL	DESCRIPTION IN INCH (Symbol Unit)	DESCRIPTION IN MM (Reference Unit)	UNIT
A	2.08	2.08	mm
A1	0.10	0.075	mm
A2	2.65	0.061	mm
B	0.51	0.012	mm
C	0.20	0.008	mm
E	10.20 REF	0.402 REF	mm
G1	2.50 REF	0.200 REF	mm
H	1.27 REF	0.050 REF	mm
I	0.40	0.016	mm
L	0.40	0.016	mm
U1	1.40 REF	0.055 REF	mm
U2	0.40 REF	0.016 REF	mm
R	0.65	0.025	mm
M	0.65	0.025	mm
Q	0.7	0.028	mm
RL	0.7	0.028	mm
Q1	0.7	0.028	mm
D	10.20 REF	0.402 REF	mm
H	1.27	0.050	mm

**EXAR CORPORATION**

16 PIN SOICW PACKAGE OUTLINE

Part No.	Rev	Issue	11/20/07	Revision	0	Sheet	1 of 1
----------	-----	-------	----------	----------	---	-------	--------

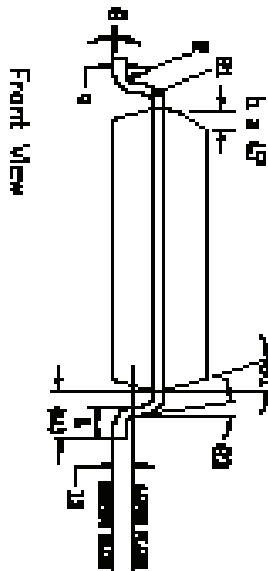
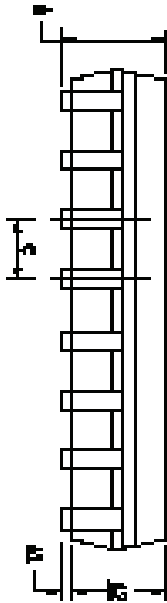
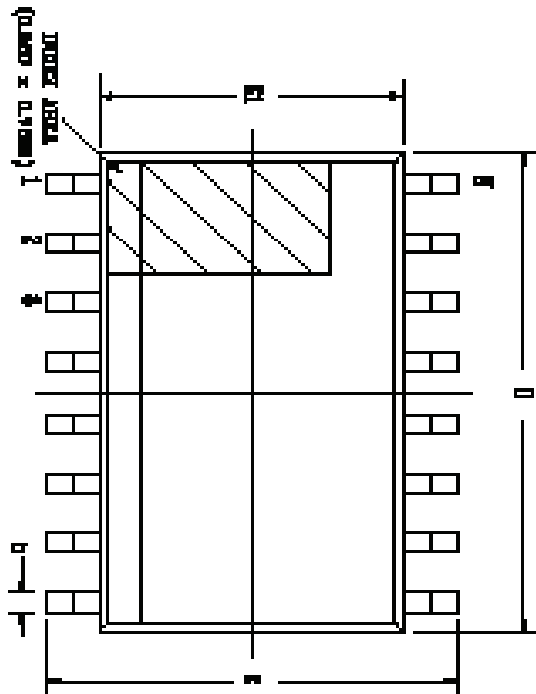

18 Pin WSOIC JDEC HS-013 Variation A/B		Dimensional Callouts		Dimensions in Inch	
Symbol	Parameter	Min	Max	Min	Max
A	Lead Length	2.26	2.66	0.089	0.105
K1	Lead Angle	4.18	0.30	0.164	0.012
M2	Lead Spacing	2.06	2.45	0.081	0.108
b	Lead Width	0.31	0.41	0.012	0.029
c	Lead Thickness	0.28	0.32	0.011	0.013
E	Body Length	10.30	10.40	0.409	0.413
G1	Body Width	7.50	7.60	0.295	0.300
H	Body Thickness	1.37	1.47	0.054	0.058
L	Body Height	0.40	1.27	0.016	0.050
L1	Lead Height	1.40	1.67	0.055	0.066
L2	Lead Height	0.20	0.20	0.008	0.008
N	Lead Spacing	0.67	0.67	0.026	0.026
N1	Lead Spacing	0.67	0.67	0.026	0.026
P	Lead Spacing	0.7	0.7	0.028	0.028
Q	Lead Spacing	0.7	0.7	0.028	0.028
R	Lead Spacing	0.7	0.7	0.028	0.028
S	Lead Spacing	0.7	0.7	0.028	0.028
T	Lead Spacing	0.7	0.7	0.028	0.028
U	Lead Spacing	0.7	0.7	0.028	0.028
V	Lead Spacing	0.7	0.7	0.028	0.028
W	Lead Spacing	0.7	0.7	0.028	0.028
X	Lead Spacing	0.7	0.7	0.028	0.028
Y	Lead Spacing	0.7	0.7	0.028	0.028
Z	Lead Spacing	0.7	0.7	0.028	0.028
18	Pin Count	18	18	0.708	0.708

REVISION HISTORY			
REV.	DESCRIPTION	DATE	APP'D.
A	INITIAL PRODUCTION	04/24/04	A
B	CHANGE DIMENSIONAL LIMIT FOR DIMENSIONAL LIMIT	11/27/07	A

**EXAR CORPORATION**

18 PIN SOIC PACKAGE OUTLINE

Package Approval: 11/27/07

Drawing No.: 18-PIN SOIC

Revision: B

Sheet: 1 of 1

PACKING REPORT				
REV	DESCRIPTION	DATE	APP'D	BY
A	PACKAGE DIMENSIONS	04/10/03		A
B	PACKING REPORT REVISIONS	05/11/03		A
D	PACKING REPORT LAYOUT AND DIMENSIONAL CHANGES	11/20/07		A

16 PIN SOIC JEDEC NS-012 VARIATION A2			
SYMBOL	DESCRIPTION IN UNITS (DIMENSIONAL UNITS)	DESCRIPTION IN INCHES (DIMENSIONAL UNITS)	MINIMUM VALUE
A	1.50	1.25	0.003
A1	0.10	0.05	0.004
A2	1.35	1.05	0.004
b	0.20	0.61	0.012
c	0.12	0.25	0.007
e	0.00 BSC	0.20 BSC	0.004 BSC
E1	1.20 BSC	0.124 BSC	0.000 BSC
F	1.57 BSC	0.000 BSC	0.000 BSC
H	0.20	0.50	0.010
L	0.40	1.22	0.014
L1	1.04 REF	0.041 REF	0.000 BSC
L2	0.25 BSC	0.010 BSC	0.000 BSC
n	0.07	0.003	—
n1	0.07	0.003	—
1	0	0	—
n1	0	0	—
n2	0	0	—
D	18.00 BSC	0.700 BSC	—
H	18	18	—

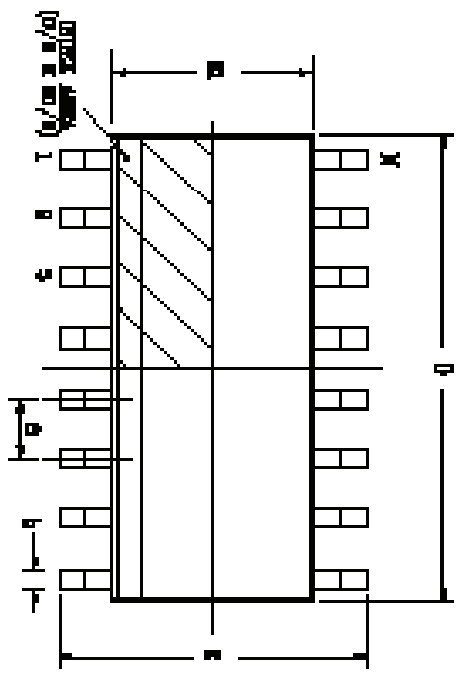

Top View

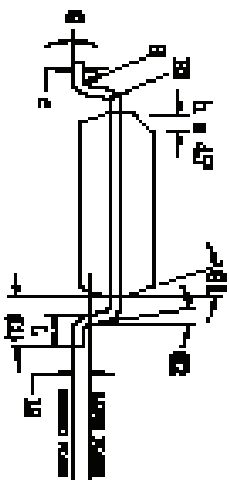

Front View

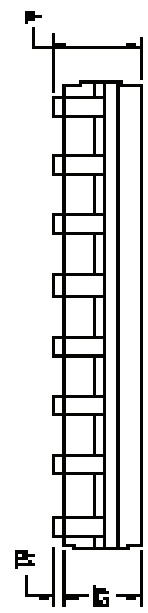

Side View

		<b>EXAR CORPORATION</b>	
Packaging Approval:		Drawing No.:	
AP	11/20/07	16-PIN SOIC	16-PIN SOIC
11/20/07		REV B	1 OF 1

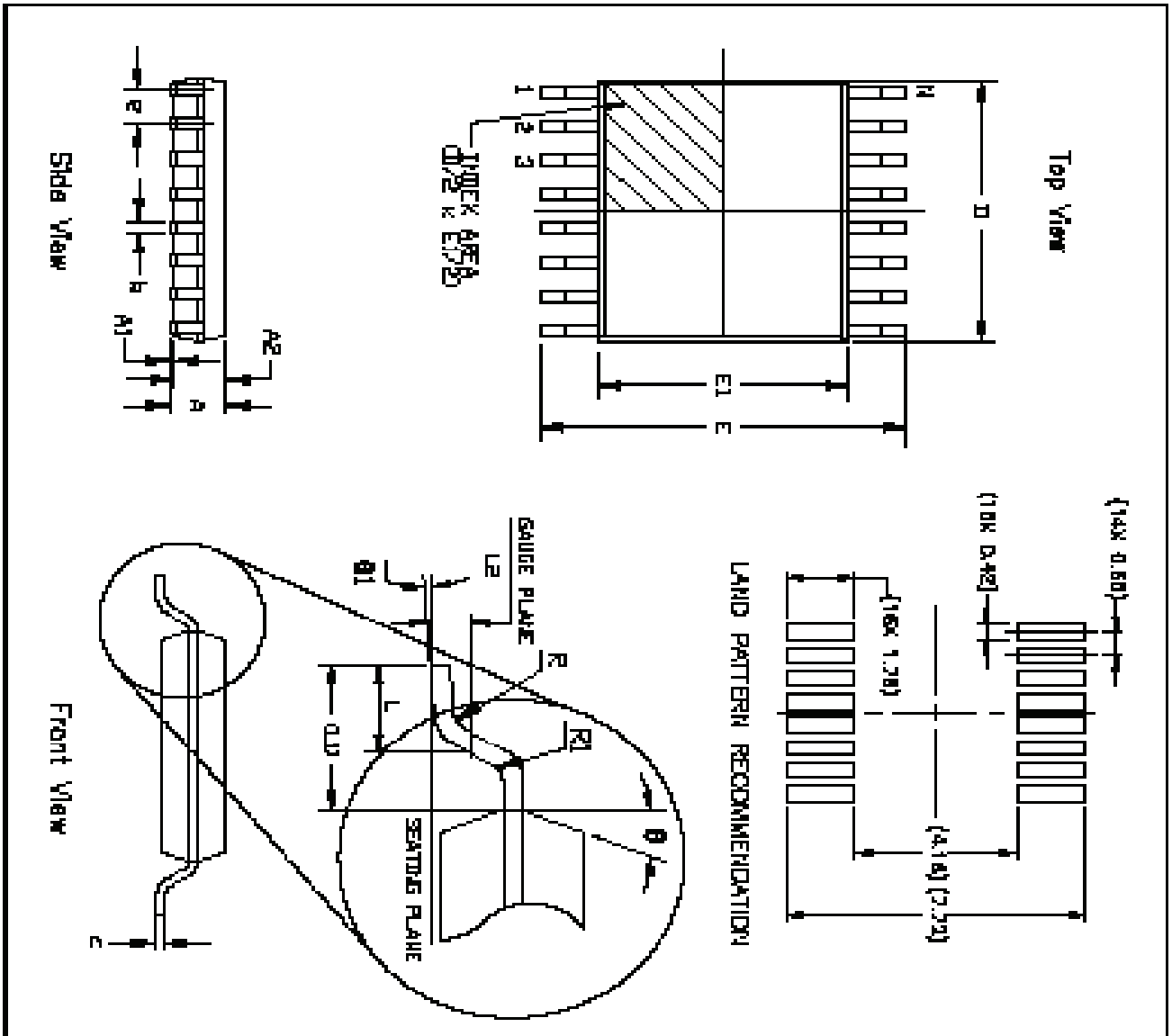

MECHANICAL DIMENSIONS			
SYMBOL	DESCRIPTION	UNIT	APPROX.
A	MAXIMUM HEIGHT	MM	1.40
B	MIN LEAD PITCH RECOMMENDATION	MILLIMETER	1.00
D	PACKAGE LENGTH	MM	11.70

16 PIN TSSOP JONES NO. 153 VARIATION A/B					
SYMBOL	DESCRIPTION IN MM (TYPICAL LIMIT)	DESCRIPTION IN INCH (TYPICAL LIMIT)	UNIT	MIN	MAX
A	—	1.30	—	—	0.0437
A1	0.04	0.10	0.002	—	0.0039
A2	0.05	1.05	0.001	0.004	0.041
B	0.10	0.20	0.002	—	0.0118
C	0.07	—	0.001	—	0.0043
E	0.40 BSC	—	0.012 BSC	—	—
E1	4.20	4.40	4.50	0.166	0.173
E	0.45 BSC	—	0.008 BSC	—	—
L	0.45	0.90	0.75	0.018	0.024
L1	1.00 REF	—	—	0.039	REF
L2	0.20 BSC	—	0.010 BSC	—	—
R	0.08	—	0.006	—	—
R1	0.08	—	0.006	—	—
Q	12° REF	—	12° REF	—	—
A1	0	—	0	—	0
D	1.85	0.00	5.10	0.185	0.187
14	—	16	—	16	—

**EXAR CORPORATION**

16 PIN TSSOP PACKAGE DIMLINE

Drawing No.: 16-PIN TSSOP

Revision: 2

11/20/07

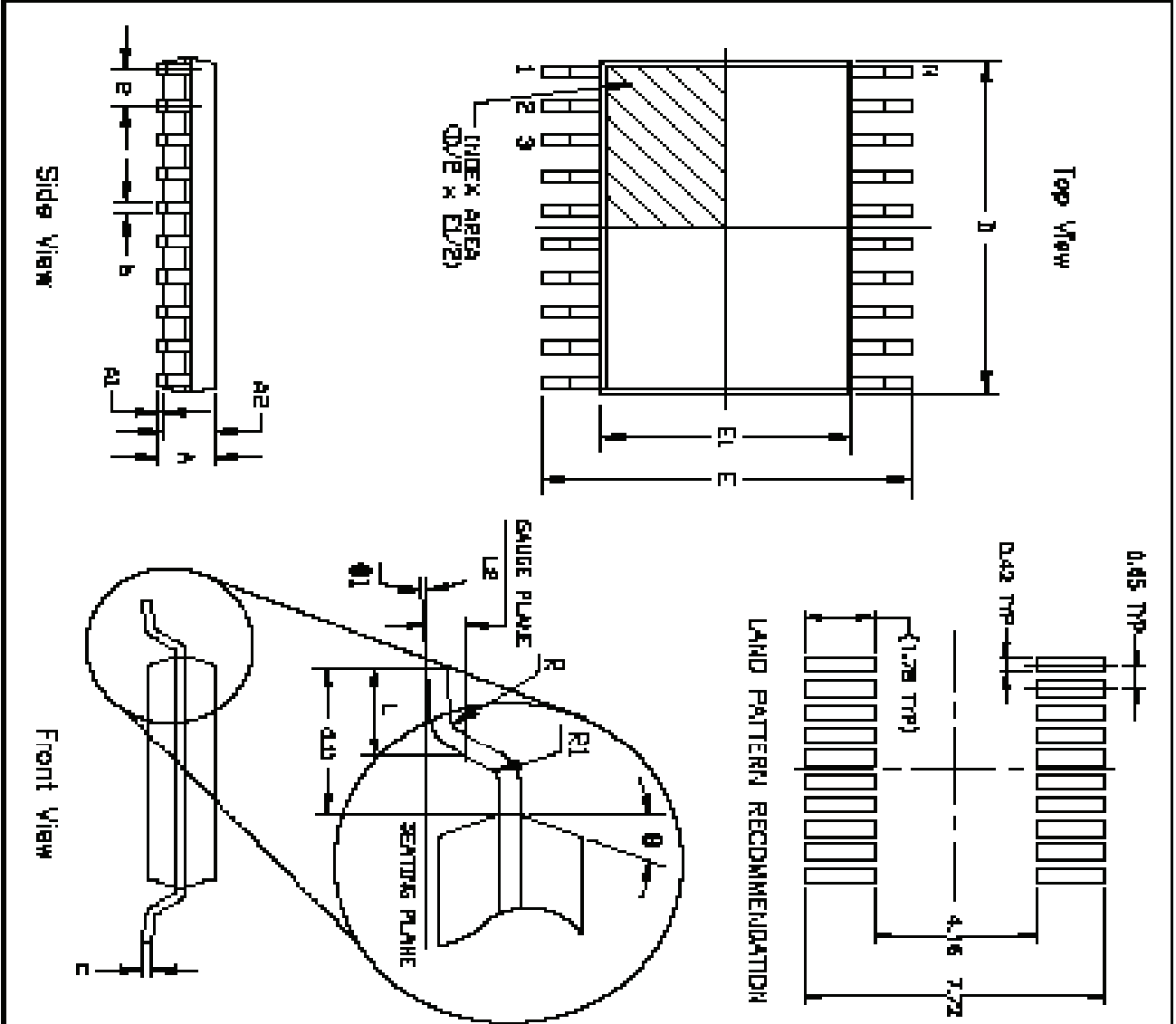

DIMENSION DEFINITION			
REL	DESCRIPTION	UNIT	ASSEMBLY
A	PACKAGE HEIGHT	MM/0.004	A
A1	LEAD FOOTER DIMENSION	MM/0.004	A
A2	LEAD THICKNESS	MM/0.004	A
D	PACKAGE WIDTH	MM/0.004	A

20 PIN TSSOP JEDEC MO-183 VARIATION #2			
DIMENSIONS IN MM		DIMENSIONS IN INCH	
SYMBOLS (Feature Unit)			
MIN	FORM	MAX	UNIT
A	—	1.25	—
A1	0.60	0.15	0.002
A2	0.40	1.05	0.001
b	0.18	0.30	0.007
c	0.08	0.20	0.004
E	0.40 BSC	0.202 BSC	—
E1	4.30	4.50	0.169 0.173 0.177
F	0.65 BSC	0.018 BSC	—
L	0.45	0.90	0.018 0.034 0.036
L1	1.00 REF	0.009 REF	—
L2	0.25 BSC	0.010 BSC	—
R	0.08	—	0.003
R1	0.08	—	0.003
Ø	12° REF	12° REF	—
Ø1	Ø	Ø	Ø
D	8.40	8.40	0.331 0.335 0.336
H	20	20	—

**EXAR CORPORATION**

20 PIN TSSOP PACKAGE DIMLINE

Drawing No: 20-PIN TSSOP

Revision: 5 SHEET 1 OF 1

Packaging Approval: 11/20/07

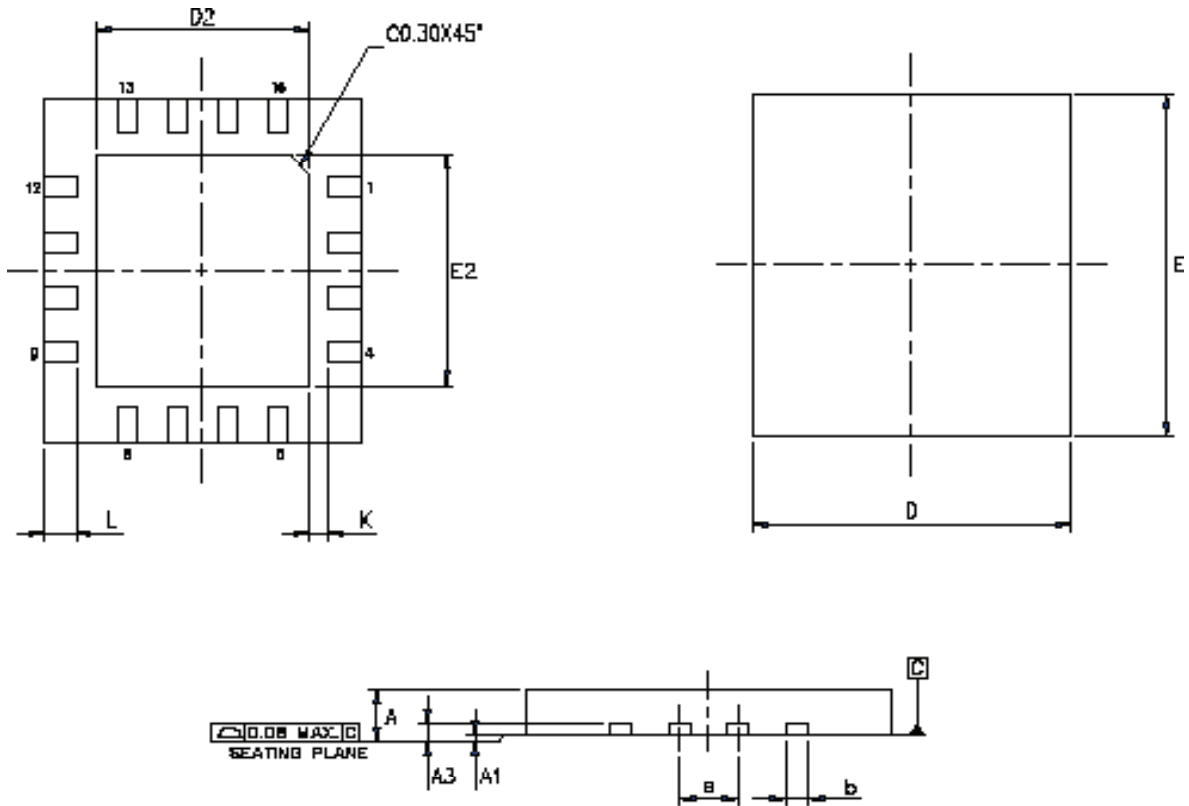

PACKAGE TYPE	
JEDEC CODE	MO-22D
PKG CODE	WQFN(YS16)
SYMBOLS	MIN. NOM. MAX.
A	0.80 0.85 0.90
A1	0.00 0.02 0.05
A3	0.203 REF.
b	0.25 0.30 0.35
D	4.85 5.00 5.05
E	4.85 5.00 5.05
e	0.80 BSC
L	0.45 0.50 0.55
K	0.20 - -

PAD SIZE	E2			D2			LEAD FINISH		JEDEC CODE
	MIN.	NOM.	MAX.	MIN.	NOM.	MAX.	Plating Th	PPF	
142X142 ML	3.28	3.38	3.43	3.28	3.38	3.43	V	X	N/A

NOTES :

1. ALL DIMENSIONS ARE IN MILLIMETERS.
2. DIMENSION b APPLIES TO METALLIZED TERMINAL AND IS MEASURED BETWEEN 0.15mm AND 0.30mm FROM THE TERMINAL TIP. IF THE TERMINAL HAS THE OPTIONAL RADIUS ON THE OTHER END OF THE TERMINAL, THE DIMENSION b SHOULD NOT BE MEASURED IN THAT RADIUS AREA.
3. BILATERAL COPLANARITY ZONE APPLIES TO THE EXPOSED HEAT SINK SLUG AS WELL AS THE TERMINALS.

## ORDERING INFORMATION

Part Number	Temp. Range	Package
SP3222EBCA-L	0°C to +70°C	20 Pin SSOP
SP3222EBCA-L/TR	0°C to +70°C	20 Pin SSOP
SP3222EBCT-L	0°C to +70°C	18 Pin WSOIC
SP3222EBCT-L/TR	0°C to +70°C	18 Pin WSOIC
SP3222EBCY-L	0°C to +70°C	20 Pin TSSOP
SP3222EBCY-L/TR	0°C to +70°C	20 Pin TSSOP
SP3222EBEA-L	-40°C to +85°C	20 Pin SSOP
SP3222EBEA-L/TR	-40°C to +85°C	20 Pin SSOP
SP3222EBET-L	-40°C to +85°C	18 Pin WSOIC
SP3222EBET-L/TR	-40°C to +85°C	18 Pin WSOIC
SP3222EBEY-L	-40°C to +85°C	20 Pin TSSOP
SP3222EBEY-L/TR	-40°C to +85°C	20 Pin TSSOP

Part Number	Temp. Range	Package
SP3232EBCA-L	0°C to +70°C	16 Pin SSOP
SP3232EBCA-L/TR	0°C to +70°C	16 Pin SSOP
SP3232EBCN-L	0°C to +70°C	16 Pin NSOIC
SP3232EBCN-L/TR	0°C to +70°C	16 Pin NSOIC
SP3232EBCT-L	0°C to +70°C	16 Pin WSOIC
SP3232EBCT-L/TR	0°C to +70°C	16 Pin WSOIC
SP3232EBCY-L	0°C to +70°C	16 Pin TSSOP
SP3232EBCY-L/TR	0°C to +70°C	16 Pin TSSOP
SP3232EBEA-L	-40°C to +85°C	16 Pin SSOP
SP3232EBEA-L/TR	-40°C to +85°C	16 Pin SSOP
SP3232EBEN-L	-40°C to +85°C	16 Pin NSOIC
SP3232EBEN-L/TR	-40°C to +85°C	16 Pin NSOIC
SP3232EBET-L	-40°C to +85°C	16 Pin WSOIC
SP3232EBET-L/TR	-40°C to +85°C	16 Pin WSOIC
SP3232EBEY-L	-40°C to +85°C	16 Pin TSSOP
SP3232EBEY-L/TR	-40°C to +85°C	16 Pin TSSOP
SP3232EBER-L	-40°C to +85°C	16 Pin QFN
SP3232EBER-L/TR	-40°C to +85°C	16 Pin QFN

Note: "/TR" is for tape and Reel option. "-L" is for lead free packaging

## REVISION HISTORY

DATE	REVISION	DESCRIPTION
11/02/05	--	Legacy Sipex Datasheet
09/09/09	1.0.0	Convert to Exar Format, Update ordering information and change revision to 1.0.0.
06/07/11	1.0.1	Remove obsolete devices per PDN 110510-01 and change ESD rating to IEC-61000-4-2.
03/14/13	1.0.2	Correct type error to RX input voltage range and TX transition region slew rate condition.
8/14/14	1.0.3	Add Max Junction temperature and package thermal information.
5/28/15	1.0.4	Update Absolute Max Rating for RxIN input voltage to +/-25V, update logo.
10/27/15	1.0.5	Add SP3232EBER (QFN_16) preliminary package option.
2/23/16	1.0.6	Remove preliminary status of QFN_16 package option.

### Notice

EXAR Corporation reserves the right to make changes to any products contained in this publication in order to improve design, performance or reliability. EXAR Corporation assumes no representation that the circuits are free of patent infringement. Charts and schedules contained herein are only for illustration purposes and may vary depending upon a user's specific application. While the information in this publication has been carefully checked; no responsibility, however, is assumed for inaccuracies.

EXAR Corporation does not recommend the use of any of its products in life support applications where the failure or malfunction of the product can reasonably be expected to cause failure of the life support system or to significantly affect its safety or effectiveness. Products are not authorized for use in such applications unless EXAR Corporation receives, in writing, assurances to its satisfaction that: (a) the risk of injury or damage has been minimized; (b) the user assumes all such risks; (c) potential liability of EXAR Corporation is adequately protected under the circumstances.

Copyright 2016 EXAR Corporation

Datasheet February 2016

Send your serial transceiver technical inquiry with technical details to: [serialtechsupport@exar.com](mailto:serialtechsupport@exar.com)

Reproduction, in part or whole, without the prior written consent of EXAR Corporation is prohibited.

## Looking for pricing, stock, or lifecycle information?

Click below to explore more details on WIN SOURCE:

- ⊖ [View SP3232EBEA-L/TR on WIN SOURCE](#)
- ⊖ [Exar Corporation](#) Information

## Optimize Your Supply Chain with WIN SOURCE Solutions

- ✓ Global Sourcing Solution
- ✓ Obsolete Management
- ✓ Cost Control Management
- ✓ Shortage Management
- ✓ Alternative Solution
- ✓ Excess Inventory Management