



**THE DATASHEET OF
SN761673DAER**



- Single chip mixer/oscillator and synthesizer
- VHF-L, VHF-H, UHF 3-band local oscillator
- I2C bus protocol
 Bi-directional data transmission
- 30V tuning voltage output
- 4ch NPN type band switch drivers
- Programmable reference divider ratio (512, 640
 or 1024)
- 5V power supply
- 32pin TSSOP package

DAE package (TOP VIEW)
 32PIN TSSOP (DAE)

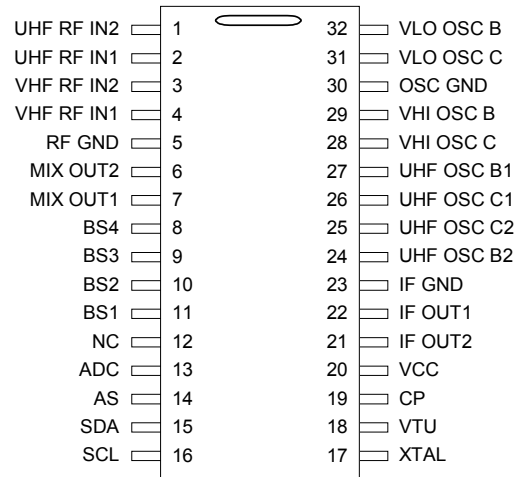

Description

SN761673DAE is a single chip synthesized tuner IC designed for TV/VCR tuning systems. The circuit consists of a PLL synthesizer, 3-band local oscillators and mixer, 30V output tuning amplifier, four NPN band switch drivers, and is available in a small package outline. 15bit programmable counter and reference divider is controlled by I2C bus protocol. Tuning step frequency is selectable by this reference divider ratio for a 4MHz X'tal oscillator.

NOTE:

The products, their specifications, service and other information appearing in this Publication are subjected to change by Texas Instruments without notice.

■ Block Diagram

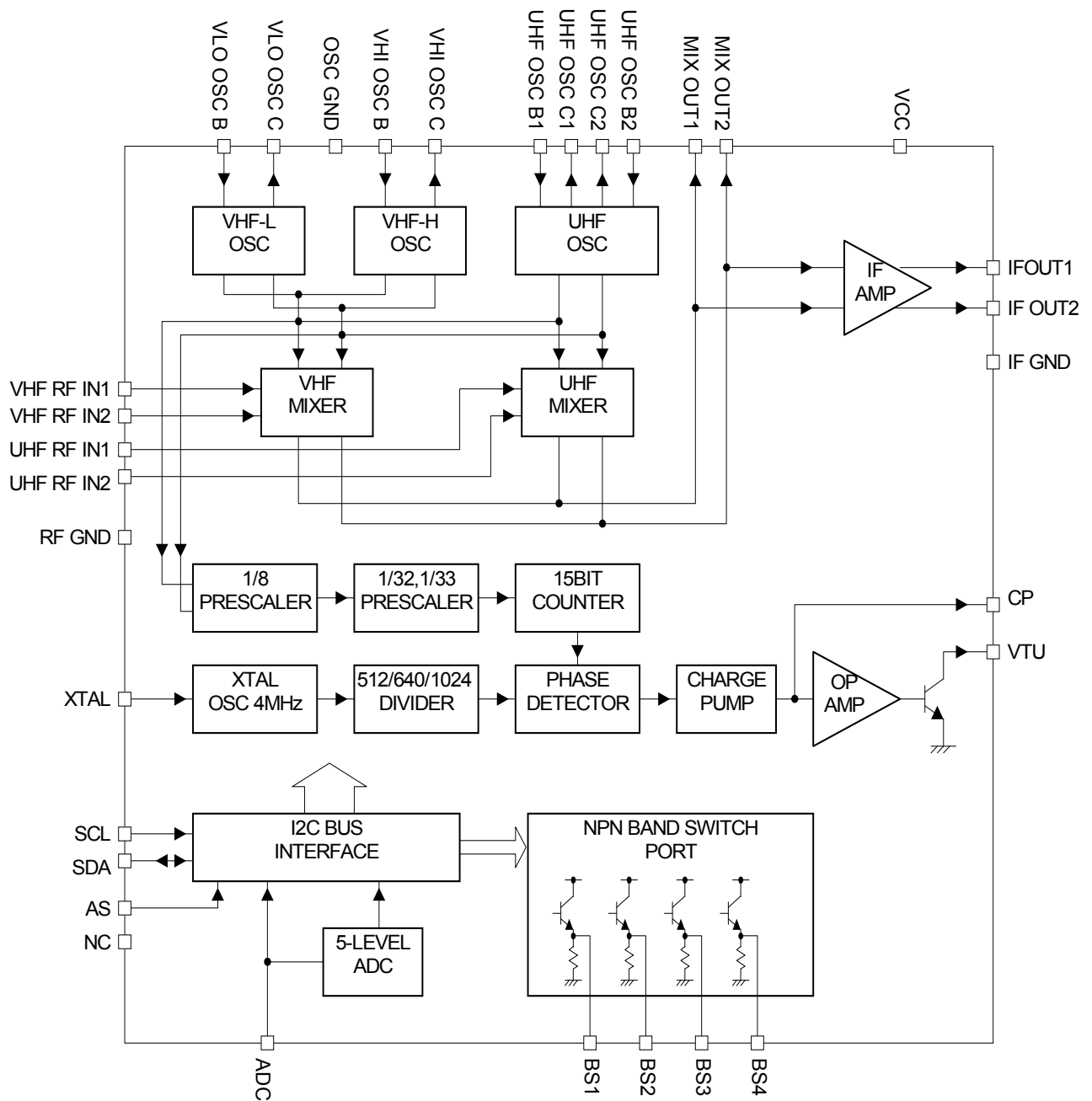

■ Pin Description

PIN	PIN NAME	PIN SCHEMATIC	DESCRIPTION
32	VLO OSC B		VHF LOW oscillator input base
31	VLO OSC C		VHF LOW oscillator output collector
30	OSC GND		OSC ground
29	VHI OSC B		VHF HI oscillator input base
28	VHI OSC C		VHF HI oscillator output collector
27	UHF OSC B1		UHF oscillator input base1
26	UHF OSC C1		UHF oscillator output collector1
25	UHF OSC C2		UHF oscillator output collector2
24	UHF OSC B2		UHF oscillator input base2
23	IF GND		IF ground
22	IF OUT1		IF output
21	IF OUT2		IF output

20	VCC		Supply voltage for Mixer/ Oscillator/PLL : 5V
19	CP		Charge pump output
18	VTU		Tuning voltage amplifier output
17	XTAL		4MHz crystal oscillator input
16	SCL		Serial clock input
15	SDA		Serial data input/output
14	AS		Address selection input
13	ADC		ADC input
12	NC		No connection
11	BS1		Band switch1 output (NPN emitter follower)
10	BS2		Band switch1 output (NPN emitter follower)
9	BS3		Band switch1 output (NPN emitter follower)
8	BS4		Band switch1 output (NPN emitter follower)

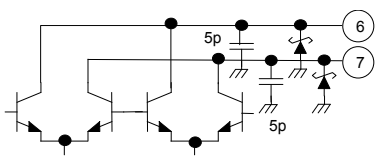
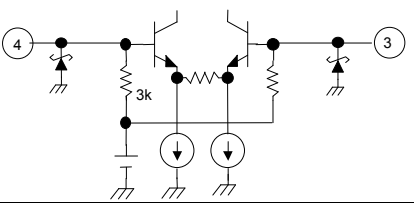
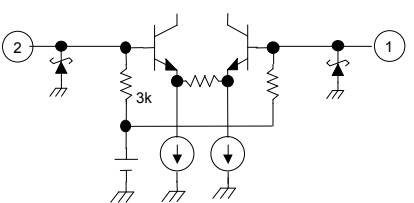
7	MIX OUT1		Mixer output
6	MIX OUT2		Mixer output
5	RF GND		RF ground
4	VHF RF IN1		VHF RF input
3	VHF RF IN2		VHF RF input
2	UHF RF IN1		UHF RF input
1	UHF RF IN2		UHF RF input

■ Absolute Maximum Rating Over Operating Free-Air Temperature

PARAMETER	CONDITIONS	SYMBOL	RATING	UNIT
SUPPLY VOLTAGE (NOTE1)	VCC (PIN 20)	V _{CC}	-0.4 ~ 7	V
INPUT VOLTAGE 1 (NOTE1)	RF GND, OSC GND (PIN 5,30)	V _{GND}	-0.4 ~ 0.4	V
INPUT VOLTAGE 2 (NOTE2)	VTU (PIN 18)	V _{VTU}	-0.4 ~ 35	V
INPUT VOLTAGE 3 (NOTE1)	OTHER PINS (PIN 1~4, 6~17, 19, 21~29, 31, 32)	V _{in}	-0.4 ~ 7	V
CONTINUOUS TOTAL DISSIPATION (NOTE2)	T _A ≤25°C	P _D	1040	mW
OPERATING FREE-AIR TEMPERATURE		T _{OPE}	-20 ~ 85	°C
STORAGE TEMPERATURE RANGE		T _{STG}	-65 ~ 150	°C
MAXIMUM JUNCTION TEMPERATURE		T _{JC}	150	°C
MAXIMUM LEAD TEMPERATURE	1.6mm(1/16 INCH) FROM CASE FOR 10SECONDS		260	°C
MAXIMUM SHORT CIRCUIT TIME	ALL PINS TO VCC ALL PINS TO IFGND,OSCGND,RFGND	t _{SC(max)}	10	s

NOTES: 1. Voltage values are with respect to the IF GND of the circuit.
2. Derating factor is 8.33mW/°C for T_A≤25°C.

■ Recommended Operating Conditions

PARAMETER	CONDITIONS	SYMBOL	MIN	NOM	MAX	UNIT
SUPPLY VOLTAGE		V _{CC}	4.5	5	5.5	V
TUNING SUPPLY VOLTAGE		V _{TU}		30	33	V
OUTPUT CURRENT OF BAND SWITCH	ONE PORT "ON"	I _{BS}			10	mA
OPERATING FREE-AIR TEMPERATURE		T _{OPE}	-20		85	°C

CAUTION:

It is advised that precautions to be taken to avoid damage due to high static voltages or electrostatic fields in handling this device. Pins 27-29 and 24 withstand 150V, and all other pins withstand 200V, according to EIAJ (0Ω, 200pF).

■ Electrical Characteristics

total device and serial interface

($V_{CC}=4.5$ to $5.5V$, $T_{OPE}=-20$ to $85^{\circ}C$, unless otherwise noted)

PARAMETER	SYMBOL	CONDITIONS	MIN	TYP	MAX	UNIT
SUPPLY CURRENT	I_{CC}	ONE BAND SWITCH "ON" ($I_{BS}=10mA$)		70	90	mA
HIGH LEVEL INPUT VOLTAGE (SCL,SDA)	V_{IH}		3.0			V
LOW LEVEL INPUT VOLTAGE (SCL,SDA)	V_{IL}				1.5	V
HIGH LEVEL INPUT CURRENT (SCL,SDA)	I_{IH}				10	μA
LOW LEVEL INPUT CURRENT (SCL,SDA)	I_{IL}		-10			μA
POWER ON RESET SUPPLY VOLTAGE	V_{POR}	THRESHOLD OF SUPPLY VOLTAGE BETWEEN RESET AND OPERATION MODE	2.1	2.8	3.5	V
I2C INTERFACE						
ADDRESS SELECT HIGH INPUT VOLTAGE(AS)	V_{ASH}	$V_{CC}=5V$	4.5		5	V
ADDRESS SELECT MID INPUT VOLTAGE(AS)	V_{ASM}	$V_{CC}=5V$	2.0		3	V
ADDRESS SELECT LOW INPUT VOLTAGE(AS)	V_{ASL}	$V_{CC}=5V$			0.5	V
ADDRESS SELECT HIGH INPUT CURRENT(AS)	I_{ASH}				10	μA
ADDRESS SELECT LOW INPUT CURRENT(AS)	I_{ASL}		-10			μA
ADC INPUT VOLTAGE	V_{ADC}	SEE TABLE-9	0		V_{CC}	V
ADC HIGH LEVEL INPUT CURRENT	I_{ADH}	$V_{ADC}=V_{CC}$			10	μA
ADC LOW LEVEL INPUT CURRENT	I_{ADL}	$V_{ADC}=0V$	-10			μA
CLOCK FREQUENCY(SCL)	F_{SCL}			100	400	kHz
LOW LEVEL OUTPUT VOLTAGE(SDA)	V_{OL}	$V_{CC}=5V, I_{OL}=3mA$			0.4	V
HIGH LEVEL OUTPUT LEAKAGE CURRENT(SDA)	I_{SDAH}	$V_{SDA}=5.5V$			10	μA
DATA HOLD TIME	$t_{HLD-DAT}$	SEE TIMING CHART, FIG-1	0			μS
BUS FREE TIME	t_{BUF}		1.3			μS
START HOLD TIME	t_{HD-STA}		0.6			μS
SCL LOW HOLD TIME	t_{LOW}		0.6			μS
SCL HIGH HOLD TIME	t_{HIGH}		0.6			μS
START SETUP TIME	t_{SU-STA}		0.6			μS
DATA SETUP TIME	t_{SU-DAT}		0.1			μS
SCL,SDA RISE TIME	t_R				0.3	μS
SCL,SDA FALL TIME	t_F				0.3	μS
STOP SETUP TIME	t_{ST-STO}		0.6			μS

PLL and band switch

($V_{CC}=4.5$ to $5.5V$, $T_{OPE}=-20$ to $85^{\circ}C$, unless otherwise noted)

PARAMETER	SYMBOL	CONDITION	MIN	TYP	MAX	UNIT
DIVIDER RATIO	N	14-BIT FREQ WORD	256		16383	
		15-BIT FREQ WORD	256		32767	
CRYSTAL OSCILLATOR	F_{XTAL}	$R_{xtal}=25\Omega$ TO 300Ω	3.2	4	4.48	MHz
CRYSTAL OSCILLATOR INPUT IMPEDANCE	Z_{XTAL}			1.6		k Ω
MINIMUM REFERENCE INPUT SENSITIVITY (XTAL)	V_{IXTAL2}	4MHz, AC coupling with 0.1 μ F			100	mVp-p
TUNING AMPLIFIER LOW LEVEL OUTPUT VOLTAGE	V_{VTUL}	$R_L=27K$, $V_{TU}=33V$	0.2	0.3	0.46	V
TUNING AMPLIFIER LEAKAGE CURRENT(OFF)	I_{VTUOFF}	OS=1, $V_{TU}=33V$			10	μ A
CHARGE PUMP HIGH LEVEL INPUT CURRENT	I_{CPH}	CP=1		280		μ A
CHARGE PUMP LOW LEVEL INPUT CURRENT	I_{CPL}	CP=0		60		μ A
CHARGE PUMP OUTPUT VOLTAGE	V_{CP}	IN-LOCK		1.95		V
CHARGE PUMP LEAKAGE CURRENT	I_{CPOFF}	T2=0, T1=1, $V_{CP}=2V$, $T_A=25^{\circ}C$	-15		+15	nA
BAND SWITCH DRIVER OUTPUT CURRENT	I_{BS}				10	mA
BAND SWITCH DRIVER OUTPUT VOLTAGE	V_{SBS1}	$I_{BS}=10mA$	3.0			V
	V_{SBS2}	$I_{BS}=10mA$, $V_{CC}=5V$, $T_A=25^{\circ}C$	3.5	3.9		V
BAND SWITCH DRIVER LEAKAGE CURRENT	I_{BSOFF}	$V_{BS}=0V$			3	μ A

mixer, oscillator, IF amplifier

(V_{cc}=5V, T_A=25°C, measured in reference measurement circuit at 50Ω system,

IF filter characteristics : f_{peak} = 43MHz; unless otherwise noted)

PARAMETER	SYMBOL	CONDITION	MIN	TYP	MAX	UNIT
CONVERSION GAIN (mixer~IF amplifier) VHF-LOW	G _{c1}	F _{in} =58MHz (NOTE3)	20	23	26	dB
	G _{c3}	F _{in} =130MHz	20	23	26	dB
CONVERSION GAIN (mixer~IF amplifier) VHF-HIGH	G _{c4}	F _{in} =136MHz (NOTE3)	20	23	26	dB
	G _{c6}	F _{in} =364MHz	20	23	26	dB
CONVERSION GAIN (mixer~IF amplifier) VHF-UHF	G _{c7}	F _{in} =370MHz (NOTE3)	22	25	28	dB
	G _{c9}	F _{in} =804MHz	20	23	26	dB
NOISE FIGURE VHF-LOW	NF ₁	F _{in} =55.25MHz		9.5	11.5	dB
	NF ₃	F _{in} =127.25MHz		9.5	11.5	dB
NOISE FIGURE VHF-HIGH	NF ₄	F _{in} =133.25MHz		10	12	dB
	NF ₆	F _{in} =361.25MHz		10	12	dB
NOISE FIGURE UHF	NF ₇	F _{in} =367.25MHz		9	11.5	dB
	NF ₉	F _{in} =801.25MHz		10	12.5	dB
1% CROSS MODULATION DISTORTION VHF-LOW	CM ₁	F _{in} =55.25MHz (NOTE4)		91		dBμV
	CM ₃	F _{in} =127.25MHz		91		dBμV
1% CROSS MODULATION DISTORTION VHF-HIGH	CM ₄	F _{in} =133.25MHz (NOTE4)		91		dBμV
	CM ₆	F _{in} =361.25MHz		91		dBμV
1% CROSS MODULATION DISTORTION UHF	CM ₇	F _{in} =367.25MHz (NOTE4)		88		dBμV
	CM ₉	F _{in} =801.25MHz		88		dBμV
IF OUTPUT VOLTAGE VHF-LOW	V _{IF01}	F _{in} =55.25MHz (NOTE5)		117		dBμV
	V _{IF03}	F _{in} =127.25MHz		117		dBμV
IF OUTPUT VOLTAGE VHF-HIGH	V _{IF04}	F _{in} =133.25MHz (NOTE5)		117		dBμV
	V _{IF06}	F _{in} =361.25MHz		117		dBμV
IF OUTPUT VOLTAGE UHF	V _{IF07}	F _{in} =367.25MHz (NOTE5)		117		dBμV
	V _{IF09}	F _{in} =801.25MHz		117		dBμV
PHASE NOISE VHF-LOW	Φ _{OSC1}	F _{in} =55.25MHz (NOTE6)		89		dBc/Hz
	Φ _{OSC3}	F _{in} =127.25MHz		89		dBc/Hz
PHASE NOISE VHF-HIGH	Φ _{OSC4}	F _{in} =133.25MHz (NOTE6)		86		dBc/Hz
	Φ _{OSC6}	F _{in} =361.25MHz		86		dBc/Hz
PHASE NOISE UHF	Φ _{OSC7}	F _{in} =367.25MHz (NOTE6)		87		dBc/Hz
	Φ _{OSC9}	F _{in} =801.25MHz		87		dBc/Hz
PRESCALER BEAT (NOTE7)					(25)	dBμV

NOTE3: IF=43MHz, RF Input level=80dBμV

NOTE4: F_{undes}=F_{des}±6MHz, Pin=80dBμV, AM 1kHz, 30%, DES/CM=S/I=46dB

NOTE5: IF=45.75MHz

NOTE6: offset=10kHz, RF Input level=70dBμV

NOTE7: Design parameter, not tested.

■ **Function Description**

The device can be controlled according to the I2C bus format.

Table 1. Serial interface function

PIN	PIN NAME	FUNCTION
17	SCL	CLOCK INPUT
18	SDA	DATA INPUT/OUTPUT
19	AS	ADDRESS SELECTION INPUT
20	ADC	ADC INPUT/TEST OUTPUT

(1) I2C BUS MODE

(1-1) I2C WRITE MODE (R/W=0)

Table 2. Write data format

	MSB							LSB	
ADDRESS BYTE (ADB)	1	1	0	0	0	MA1	MA0	R/W=0	A
DIVIDER BYTE 1 (DB1)	0	N14	N13	N12	N11	N10	N9	N8	A
DIVIDER BYTE 2 (DB2)	N7	N6	N5	N4	N3	N2	N1	N0	A
CONTROL BYTE (CB)	1	CP	T2	T1	T0	RSA	RSB	OS	A
BANDSWITCH BYTE (BB)	X	X	X	X	BS4	BS3	BS2	BS1	A

A: Acknowledge

Table 3. Description of data symbol

SYMBOL	DESCRIPTION	DEFAULT																																													
MA1,MA0	ADDRESS SET BITS (SEE TABLE-4 ADDRESS SELECTION)																																														
N14...N0	PROGRAMMABLE COUNTER SET BITS $N=N14*2^{14}+N13*2^{13}+...+N1*2+N0$	$N_n=0$																																													
CP	CHARGE PUMP CURRENT SET BIT 60uA(CP=0) 280uA(CP=1)	CP=1																																													
T2,T1,T0	TEST BITS(SEE TABLE-5 TEST BITS) NORMAL MODE: T2=0,T1=0,T0=1/0	T2=0,T1=0,T0=1																																													
RSA,RSB	REFERENCE DIVIDER RATIO SELECTION BITS (SEE TABLE-6 REFERENCE DIVIDER RATIO)	RSA=0,RSB=1																																													
OS	TUNING AMPLIFIER CONTROL BIT TUNING VOLTAGE ON(OS=0) TUNING VOLTAGE OFF, HIGH IMPEDANCE(OS=1)	OS=0																																													
BS4...BS1	BAND SELECTION BY BS1,2,4 and BAND SWITCH PORT1,2,4 STATUS <table style="margin-left: 20px; border-collapse: collapse;"> <thead> <tr> <th>BS4</th> <th>BS2</th> <th>BS1</th> <th>Selected Band</th> <th>ON Port</th> </tr> </thead> <tbody> <tr><td>0</td><td>0</td><td>0</td><td>UHF</td><td>4</td></tr> <tr><td>0</td><td>0</td><td>1</td><td>VHF-LO</td><td>1</td></tr> <tr><td>0</td><td>1</td><td>0</td><td>VHF-HI</td><td>2</td></tr> <tr><td>0</td><td>1</td><td>1</td><td>VHF-HI</td><td>1,2</td></tr> <tr><td>1</td><td>0</td><td>0</td><td>UHF</td><td>4</td></tr> <tr><td>1</td><td>0</td><td>1</td><td>UHF</td><td>1,4</td></tr> <tr><td>1</td><td>1</td><td>0</td><td>UHF</td><td>2,4</td></tr> <tr><td>1</td><td>1</td><td>1</td><td>UHF</td><td>1,2,4</td></tr> </tbody> </table> BAND SWITCH PORT 3 CONTROL BIT BS3=0:OFF, BS3=1:ON	BS4	BS2	BS1	Selected Band	ON Port	0	0	0	UHF	4	0	0	1	VHF-LO	1	0	1	0	VHF-HI	2	0	1	1	VHF-HI	1,2	1	0	0	UHF	4	1	0	1	UHF	1,4	1	1	0	UHF	2,4	1	1	1	UHF	1,2,4	BS _n =0
BS4	BS2	BS1	Selected Band	ON Port																																											
0	0	0	UHF	4																																											
0	0	1	VHF-LO	1																																											
0	1	0	VHF-HI	2																																											
0	1	1	VHF-HI	1,2																																											
1	0	0	UHF	4																																											
1	0	1	UHF	1,4																																											
1	1	0	UHF	2,4																																											
1	1	1	UHF	1,2,4																																											
X	DON'T CARE																																														

Table 4. Address selection

VOLTAGE APPLIED ON AS INPUT	MA1	MA0
0V TO 0.1V _{cc}	0	0
ALWAYS VALID	0	1
0.4V _{cc} TO 0.6V _{cc}	1	0
0.9V _{cc} TO V _{cc}	1	1

Table 5. Test bits (NOTE 8)

T2	T1	T0	FUNCTION	
0	0	0	NORMAL OPERATION	
0	0	1	NORMAL OPERATION	DEFAULT
0	1	X	CHARGE PUMP "OFF"	
1	1	0	CHARGE PUMP "SINK"	
1	1	1	CHARGE PUMP "SOURCE"	
1	0	0	REFERENCE COUNTER OUTPUT IS AVAILABLE ON PIN ADC	NOT AVAILABLE ADC
1	0	1	MAIN COUNTER OUTPUT IS AVAILABLE ON PIN ADC (NOTE 9)	NOT AVAILABLE ADC

NOTE 8: Not used for other bit-patterns.

NOTE 9: Main counter input is bypassed 1/8 and 1/32,1/33 prescaler from oscillator, at this mode.
 (F_{osc} ≤ 4MHz)

Table 6. Ratio select bits

RSA	RSB	REFERENCE DIVIDER RATIO
X	0	640
0	1	1024
1	1	512

(1-2) I2C Read mode(R/W=1)

Table 7. Read data format

	MSB							LSB	
ADDRESS BYTE (ADB)	1	1	0	0	0	MA1	MA0	R/W=1	A
STATUS BYTE (SB)	POR	FL	1	1	1	A2	A1	A0	A

A:Acknowledge

Table 8. Description of data symbol

SYMBOL	DESCRIPTION	DEFAULT
MA1,MA0	ADDRESS SET BITS (SEE TABLE-4 ADDRESS SELECTION)	
POR	POWER-ON RESET FLAG POR SET : POWER ON POR RESET : END-OF-DATA TRANSMISSION PROCEDURE	POR=1
FL	IN-LOCK FLAG PLL LOCK(FL=1) UNLOCK(FL=0)	
A2...A0	DIGITAL DATA OF ADC(SEE TABLE-9 ADC LEVE)	

Table 9. ADC level

VOLTAGE APPLIED ON ADC INPUT	A2	A1	A0
0.6Vcc TO Vcc	1	0	0
0.45Vcc TO 0.6Vcc	0	1	1
0.3Vcc TO 0.45Vcc	0	1	0
0.15Vcc TO 0.3Vcc	0	0	1
0 TO 0.15Vcc	0	0	0

NOTE 9: Accuracy is 0.03xVcc.

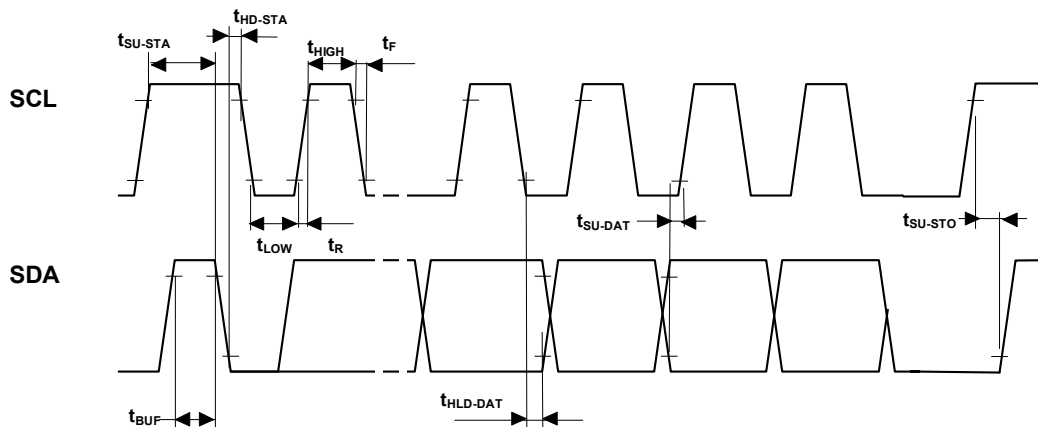

Figure 1. I2C timing chart

■ Application Information

Reference measurement circuit

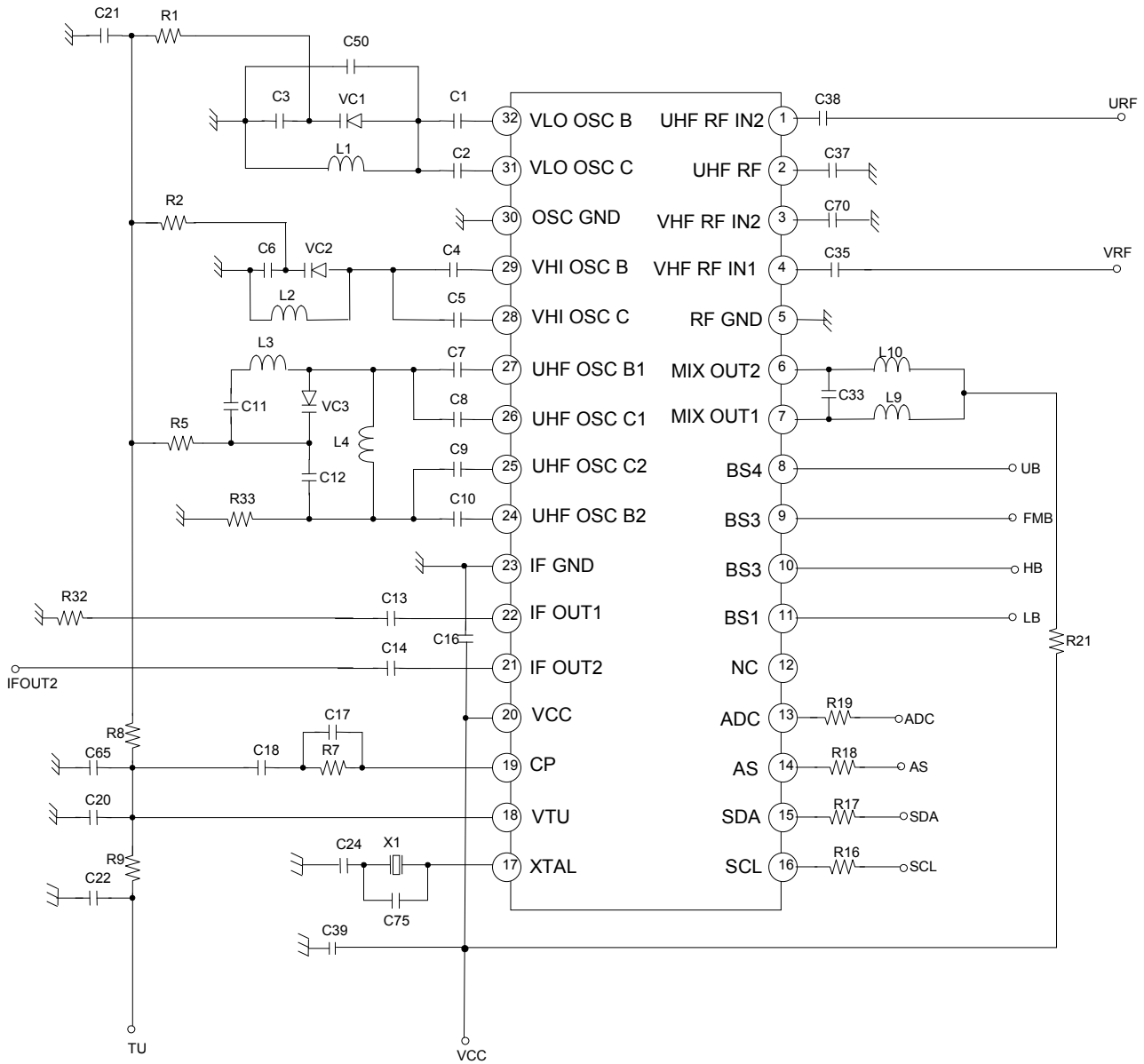

Figure7. Reference measurement circuit

NOTE 11: This application information is advisory and performance-check is required at actual application circuits.

■ Component Values for Measurement Circuit

PARTS NAME	VALUE	PARTS NAME	VALUE
U1	SN761672A	C1	1p
		C2	1p
VC1	1T363A	C3	47p
VC2	1T363A	C4	2p
VC3	1T363A	C5	3p
		C6	86p
L1	φ3.0mm 8T	C7	1.5p
L2	φ2.4mm 4T	C8	1.5p
L3	φ3.0mm 2T	C9	1.5p
L4	φ2.0mm 3T	C10	1.5p
L9	φ2.4mm 15T	C11	100p
L10	φ2.4mm 15T	C12	12p
		C13	2.2n
X1	X'tal 4MHz	C14	2.2n
		C16	2.2n
R1	33k	C17	2.2n
R2	33k	C18	0.1u
R5	33k	C20	2.2n
R7	22k	C21	2.2n
R8	33k	C22	2.2n
R9	22k	C24	5p
R16	330		
R17	330		
R18	330	C33	27p
R21	0	C35	2.2n
R19	330	C37	2.2n
		C38	2.2n
R32	56	C39	2.2n
R33	22k	C50	3p
		C65	2.2n
		C70	2.2n
		C75	10p

■ Test Circuit

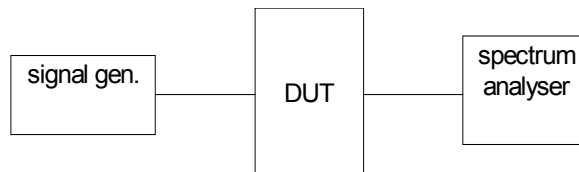

Figure 8. Measurement circuit of conversion gain

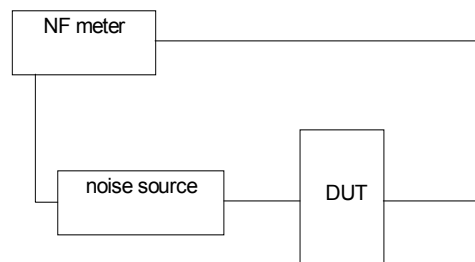

Figure 9. Noise Figure measurement circuit

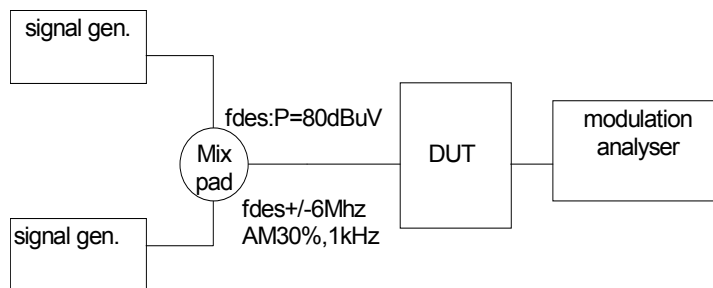
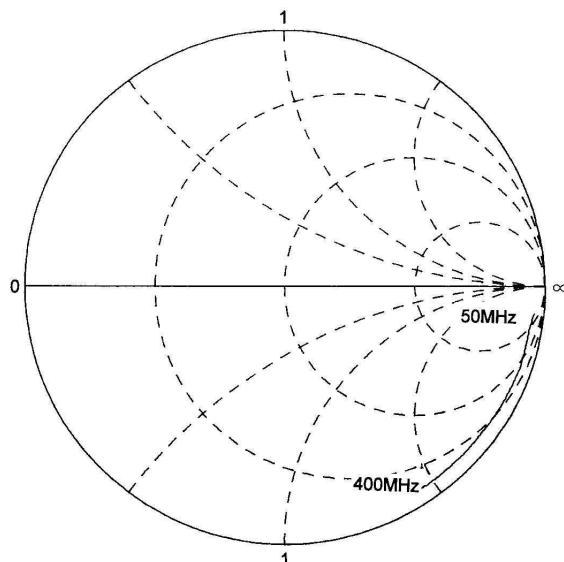

Figure 10 1% Cross modulation distortion measurement circuit

■ Typical Characteristics

S-parameter

VHF-input



UHF-input

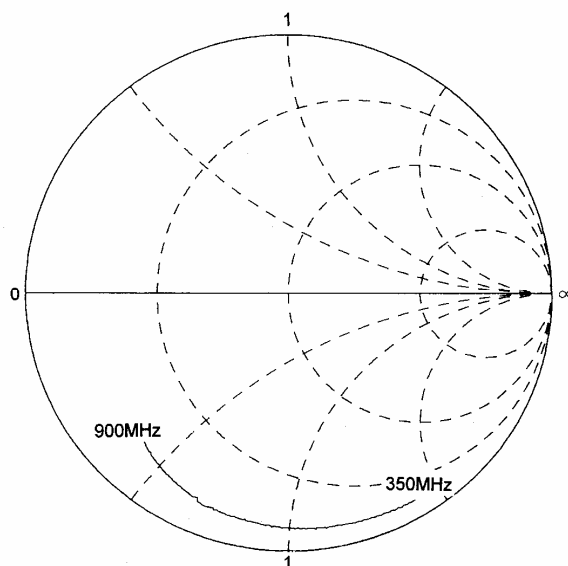

IF-output

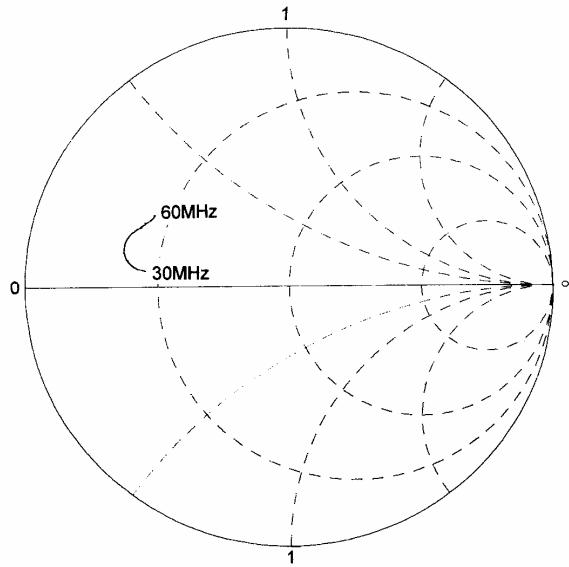

Band switch driver output voltage

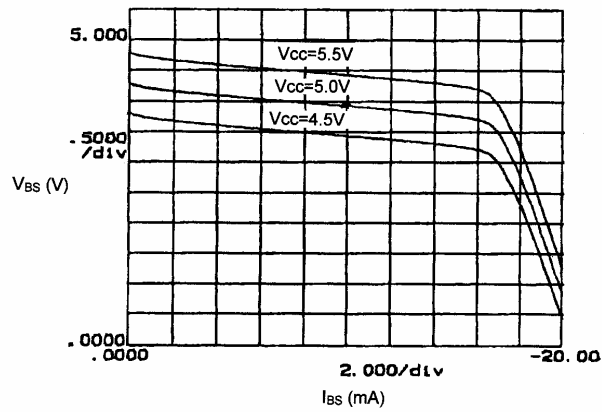

■ Mechanical Data

DAE (32pin Thin Shrink Small Outline Package)

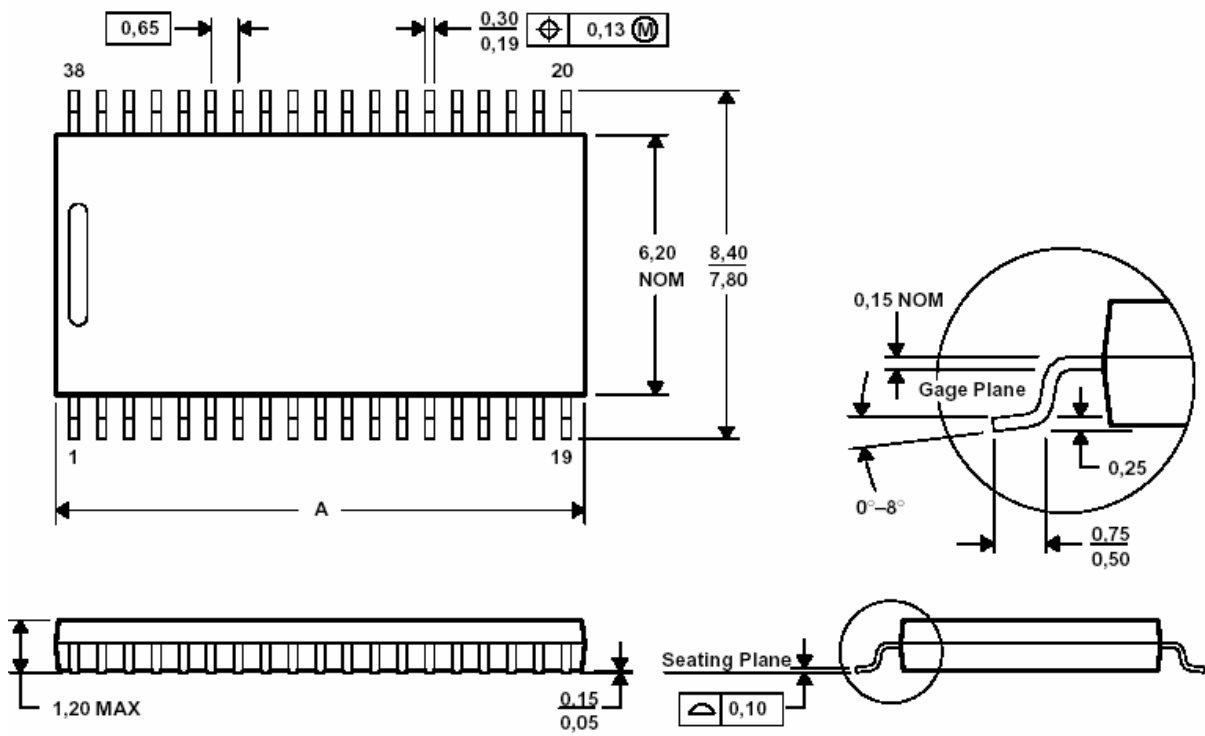



DIM \ PINS **	30	32	38
	A MAX	11,10	11,10
A MIN	10,90	10,90	12,40

UNIT : mm

Looking for pricing, stock, or lifecycle information?

Click below to explore more details on WIN SOURCE:

-  [View SN761673DAER on WIN SOURCE](#)
-  [Texas Instruments](#) Information

Optimize Your Supply Chain with WIN SOURCE Solutions

-  Global Sourcing Solution
-  Obsolete Management
-  Cost Control Management
-  Shortage Management
-  Alternative Solution
-  Excess Inventory Management