



# THE DATASHEET OF 74HCT107N



# 74HC107; 74HCT107

Dual JK flip-flop with reset; negative-edge trigger

Rev. 4 — 26 January 2015

Product data sheet

## 1. General description

The 74HC107; 74HCT107 is a dual negative edge triggered JK flip-flop featuring individual J and K inputs, clock ( $\overline{CP}$ ) and reset ( $\overline{R}$ ) inputs and complementary Q and  $\overline{Q}$  outputs. The reset is an asynchronous active LOW input and operates independently of the clock input. The J and K inputs control the state changes of the flip-flops as described in the mode select function table. The J and K inputs must be stable one set-up time prior to the HIGH-to-LOW clock transition for predictable operation. Inputs include clamp diodes that enable the use of current limiting resistors to interface inputs to voltages in excess of  $V_{CC}$ .

## 2. Features and benefits

- Complies with JEDEC standard no. 7A
- Input levels:
  - ◆ The 74HC107: CMOS levels
  - ◆ The 74HCT107: TTL levels
- ESD protection:
  - ◆ HBM JESD22-A114F exceeds 2000 V
  - ◆ MM JESD22-A115-A exceeds 200 V
- Multiple package options
- Specified from  $-40\text{ }^{\circ}\text{C}$  to  $+85\text{ }^{\circ}\text{C}$  and from  $-40\text{ }^{\circ}\text{C}$  to  $+125\text{ }^{\circ}\text{C}$

## 3. Ordering information

Table 1. Ordering information

Type number	Package			
	Temperature range	Name	Description	Version
74HC107N	$-40\text{ }^{\circ}\text{C}$ to $+125\text{ }^{\circ}\text{C}$	DIP14	plastic dual in-line package; 14 leads (300 mil)	SOT27-1
74HCT107N				
74HC107D	$-40\text{ }^{\circ}\text{C}$ to $+125\text{ }^{\circ}\text{C}$	SO14	plastic small outline package; 14 leads; body width 3.9 mm	SOT108-1
74HCT107D				
74HC107DB	$-40\text{ }^{\circ}\text{C}$ to $+125\text{ }^{\circ}\text{C}$	SSOP14	plastic shrink small outline package; 14 leads; body width 5.3 mm	SOT337-1
74HC107PW	$-40\text{ }^{\circ}\text{C}$ to $+125\text{ }^{\circ}\text{C}$	TSSOP14	plastic thin shrink small outline package; 14 leads; body width 4.4 mm	SOT402-1



## 4. Functional diagram

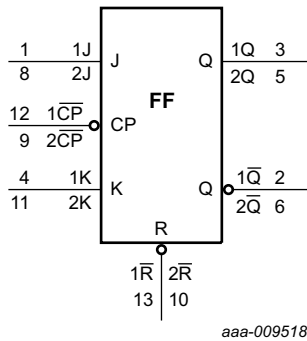

Fig 1. Logic symbol

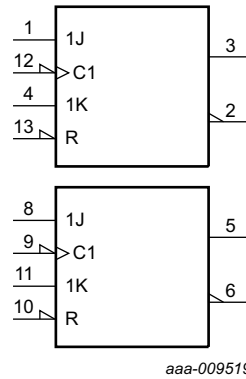

Fig 2. IEC logic symbol

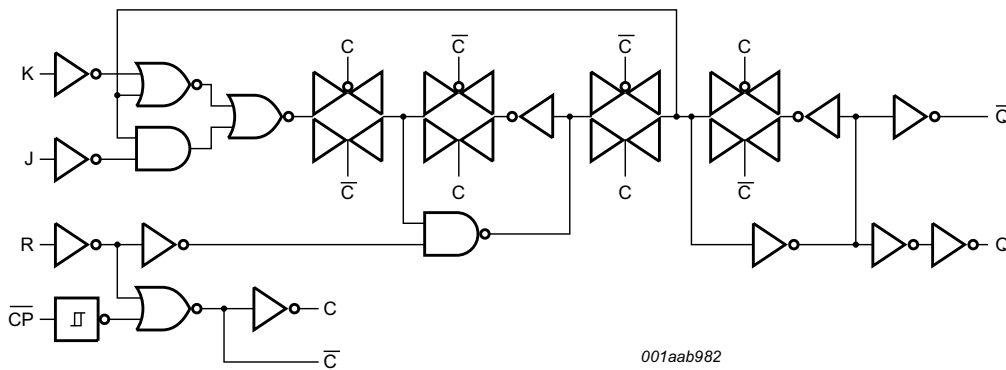

Fig 3. Logic diagram (one flip-flop)

## 5. Pinning information

### 5.1 Pinning

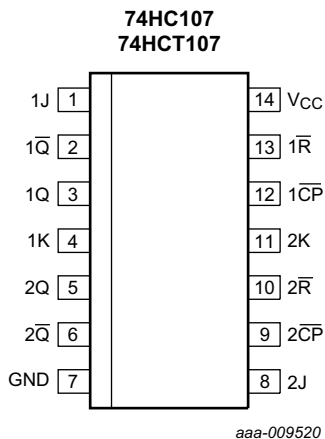

Fig 4. Pin configuration DIP14, SO14 and (T)SSOP14

### 5.2 Pin description

Table 2. Pin description

Symbol	Pin	Description
1J, 2J	1, 8	synchronous J input
1Q̄, 2Q̄	2, 6	complement output
1Q, 2Q	3, 5	true output
1K, 2K	4, 11	synchronous K input
1CP̄, 2CP̄	12, 9	clock input (HIGH-to-LOW edge-triggered)
1R̄, 2R̄	13, 10	asynchronous reset input (active LOW)
GND	7	ground (0 V)
V <sub>CC</sub>	14	supply voltage

## 6. Functional description

Table 3. Function table<sup>[1]</sup>

Input				Output		Operating mode
R	CP	J	K	Q	Q̄	
L	X	X	X	L	H	asynchronous reset
H	↓	h	h	q̄	q	toggle
H	↓	l	h	L	H	load 0 (reset)
H	↓	h	l	H	L	load 1 (set)
H	↓	l	l	q	q̄	hold (no change)

- [1] H = HIGH voltage level;  
 h = HIGH voltage level one set-up time prior to the HIGH-to-LOW clock transition;  
 L = LOW voltage level;  
 l = LOW voltage level one set-up time prior to the HIGH-to-LOW clock transition;  
 q = state of referenced output one set-up time prior to the HIGH-to-LOW clock transition;  
 X = don't care;  
 ↓ = HIGH-to-LOW clock transition.

## 7. Limiting values

Table 4. Limiting values

In accordance with the Absolute Maximum Rating System (IEC 60134). Voltages are referenced to GND (ground = 0 V).

Symbol	Parameter	Conditions	Min	Max	Unit
V <sub>CC</sub>	supply voltage		-0.5	+7.0	V
I <sub>IK</sub>	input clamping current	V <sub>I</sub> < -0.5 V or V <sub>I</sub> > V <sub>CC</sub> + 0.5 V <sup>[1]</sup>	-	±20	mA
I <sub>OK</sub>	output clamping current	V <sub>O</sub> < -0.5 V or V <sub>O</sub> > V <sub>CC</sub> + 0.5 V <sup>[1]</sup>	-	±20	mA
I <sub>O</sub>	output current	V <sub>O</sub> = -0.5 V to V <sub>CC</sub> + 0.5 V	-	±25	mA
I <sub>CC</sub>	supply current		-	50	mA
I <sub>GND</sub>	ground current		-50	-	mA
T <sub>stg</sub>	storage temperature		-65	+150	°C
P <sub>tot</sub>	total power dissipation	T <sub>amb</sub> = -40 °C to +125 °C			
		DIP14 package <sup>[2]</sup>	-	750	mW
		SO14 package <sup>[3]</sup>	-	500	mW
		(T)SSOP14 package <sup>[4]</sup>	-	500	mW

- [1] The input and output voltage ratings may be exceeded if the input and output current ratings are observed.  
 [2] P<sub>tot</sub> derates linearly with 12 mW/K above 70 °C.  
 [3] P<sub>tot</sub> derates linearly with 8 mW/K above 70 °C.  
 [4] P<sub>tot</sub> derates linearly with 5.5 mW/K above 60 °C.

## 8. Recommended operating conditions

**Table 5. Recommended operating conditions**

Voltages are referenced to GND (ground = 0 V)

Symbol	Parameter	Conditions	74HC107			74HCT107			Unit
			Min	Typ	Max	Min	Typ	Max	
V <sub>CC</sub>	supply voltage		2.0	5.0	6.0	4.5	5.0	5.5	V
V <sub>I</sub>	input voltage		0	-	V <sub>CC</sub>	0	-	V <sub>CC</sub>	V
V <sub>O</sub>	output voltage		0	-	V <sub>CC</sub>	0	-	V <sub>CC</sub>	V
T <sub>amb</sub>	ambient temperature		-40	+25	+125	-40	+25	+125	°C
Δt/ΔV	input transition rise and fall rate	V <sub>CC</sub> = 2.0 V	-	-	625	-	-	-	ns/V
		V <sub>CC</sub> = 4.5 V	-	1.67	139	-	1.67	139	ns/V
		V <sub>CC</sub> = 6.0 V	-	-	83	-	-	-	ns/V

## 9. Static characteristics

**Table 6. Static characteristics**

At recommended operating conditions; voltages are referenced to GND (ground = 0 V).

Symbol	Parameter	Conditions	25 °C			-40 °C to +85 °C		-40 °C to +125 °C		Unit
			Min	Typ	Max	Min	Max	Min	Max	
<b>74HC107</b>										
V <sub>IH</sub>	HIGH-level input voltage	V <sub>CC</sub> = 2.0 V	1.5	1.2	-	1.5	-	1.5	-	V
		V <sub>CC</sub> = 4.5 V	3.15	2.4	-	3.15	-	3.15	-	V
		V <sub>CC</sub> = 6.0 V	4.2	3.2	-	4.2	-	4.2	-	V
V <sub>IL</sub>	LOW-level input voltage	V <sub>CC</sub> = 2.0 V	-	0.8	0.5	-	0.5	-	0.5	V
		V <sub>CC</sub> = 4.5 V	-	2.1	1.35	-	1.35	-	1.35	V
		V <sub>CC</sub> = 6.0 V	-	2.8	1.8	-	1.8	-	1.8	V
V <sub>OH</sub>	HIGH-level output voltage	V <sub>I</sub> = V <sub>IH</sub> or V <sub>IL</sub>								
		I <sub>O</sub> = -20 μA; V <sub>CC</sub> = 2.0 V	1.9	2.0	-	1.9	-	1.9	-	V
		I <sub>O</sub> = -20 μA; V <sub>CC</sub> = 4.5 V	4.4	4.5	-	4.4	-	4.4	-	V
		I <sub>O</sub> = -20 μA; V <sub>CC</sub> = 6.0 V	5.9	6.0	-	5.9	-	5.9	-	V
		I <sub>O</sub> = -4.0 mA; V <sub>CC</sub> = 4.5 V	3.98	4.32	-	3.84	-	3.7	-	V
V <sub>OL</sub>	LOW-level output voltage	V <sub>I</sub> = V <sub>IH</sub> or V <sub>IL</sub>								
		I <sub>O</sub> = 20 μA; V <sub>CC</sub> = 2.0 V	-	0	0.1	-	0.1	-	0.1	V
		I <sub>O</sub> = 20 μA; V <sub>CC</sub> = 4.5 V	-	0	0.1	-	0.1	-	0.1	V
		I <sub>O</sub> = 20 μA; V <sub>CC</sub> = 6.0 V	-	0	0.1	-	0.1	-	0.1	V
		I <sub>O</sub> = 4.0 mA; V <sub>CC</sub> = 4.5 V	-	0.15	0.26	-	0.33	-	0.4	V
I <sub>l</sub>	input leakage current	V <sub>I</sub> = V <sub>CC</sub> or GND; V <sub>CC</sub> = 6.0 V	-	-	±0.1	-	±1.0	-	±1.0	μA
		V <sub>I</sub> = V <sub>CC</sub> or GND; I <sub>O</sub> = 0 A; V <sub>CC</sub> = 6.0 V	-	-	4.0	-	40	-	80	μA

**Table 6. Static characteristics ...continued**

At recommended operating conditions; voltages are referenced to GND (ground = 0 V).

Symbol	Parameter	Conditions	25 °C			-40 °C to +85 °C		-40 °C to +125 °C		Unit
			Min	Typ	Max	Min	Max	Min	Max	
C <sub>I</sub>	input capacitance		-	3.5	-					pF
<b>74HCT107</b>										
V <sub>IH</sub>	HIGH-level input voltage	V <sub>CC</sub> = 4.5 V to 5.5 V	2.0	1.6	-	2.0	-	2.0	-	V
V <sub>IL</sub>	LOW-level input voltage	V <sub>CC</sub> = 4.5 V to 5.5 V	-	1.2	0.8	-	0.8	-	0.8	V
V <sub>OH</sub>	HIGH-level output voltage	V <sub>I</sub> = V <sub>IH</sub> or V <sub>IL</sub> ; V <sub>CC</sub> = 4.5 V								
		I <sub>O</sub> = -20 µA	4.4	4.5	-	4.4	-	4.4	-	V
		I <sub>O</sub> = -4 mA	3.98	4.32	-	3.84	-	3.7	-	V
V <sub>OL</sub>	LOW-level output voltage	V <sub>I</sub> = V <sub>IH</sub> or V <sub>IL</sub> ; V <sub>CC</sub> = 4.5 V								
		I <sub>O</sub> = 20 µA	-	0	0.1	-	0.1	-	0.1	V
		I <sub>O</sub> = 4.0 mA	-	0.16	0.26	-	0.33	-	0.4	V
I <sub>I</sub>	input leakage current	V <sub>I</sub> = V <sub>CC</sub> or GND; V <sub>CC</sub> = 5.5 V	-	-	±0.1	-	±1.0	-	±1.0	µA
I <sub>CC</sub>	supply current	V <sub>I</sub> = V <sub>CC</sub> or GND; I <sub>O</sub> = 0 A; V <sub>CC</sub> = 5.5 V	-	-	4.0	-	40	-	80	µA
ΔI <sub>CC</sub>	additional supply current	per input pin; V <sub>I</sub> = V <sub>CC</sub> - 2.1 V; I <sub>O</sub> = 0 A; other inputs at V <sub>CC</sub> or GND; V <sub>CC</sub> = 4.5 V to 5.5 V								
		pin nCP, nJ	-	100	360	-	450	-	490	µA
		pin nR	-	65	234	-	293	-	319	µA
		pin nK	-	60	216	-	270	-	294	µA
C <sub>I</sub>	input capacitance		-	3.5	-	-	-	-	-	pF

## 10. Dynamic characteristics

**Table 7. Dynamic characteristics**

GND (ground = 0 V);  $C_L = 50$  pF unless otherwise specified; for test circuit, see [Figure 7](#)

Symbol	Parameter	Conditions	25 °C			-40 °C to +85 °C		-40 °C to +125 °C		Unit
			Min	Typ	Max	Min	Max	Min	Max	
<b>74HC107</b>										
$t_{pd}$	propagation delay	$\overline{nCP}$ to nQ; see <a href="#">Figure 5</a> <sup>[1]</sup>								
		$V_{CC} = 2.0$ V	-	52	160	-	200	-	240	ns
		$V_{CC} = 4.5$ V	-	19	32	-	40	-	48	ns
		$V_{CC} = 5.0$ V; $C_L = 15$ pF	-	16	-	-	-	-	-	ns
		$V_{CC} = 6.0$ V	-	15	27	-	34	-	41	ns
		$\overline{nCP}$ to $\overline{nQ}$ ; see <a href="#">Figure 5</a>								
		$V_{CC} = 2.0$ V	-	52	160	-	200	-	240	ns
		$V_{CC} = 4.5$ V	-	19	32	-	40	-	48	ns
		$V_{CC} = 5.0$ V; $C_L = 15$ pF	-	16	-	-	-	-	-	ns
		$V_{CC} = 6.0$ V	-	15	27	-	34	-	41	ns
		$\overline{nR}$ to nQ, $\overline{nQ}$ ; see <a href="#">Figure 6</a>								
		$V_{CC} = 2.0$ V	-	52	155	-	195	-	235	ns
		$V_{CC} = 4.5$ V	-	19	31	-	39	-	47	ns
$V_{CC} = 5.0$ V; $C_L = 15$ pF	-	16	-	-	-	-	-	ns		
$V_{CC} = 6.0$ V	-	15	26	-	33	-	40	ns		
$t_t$	transition time	nQ, $\overline{nQ}$ ; see <a href="#">Figure 5</a> <sup>[2]</sup>								
		$V_{CC} = 2.0$ V	-	19	75	-	95	-	110	ns
		$V_{CC} = 4.5$ V	-	7	15	-	19	-	22	ns
		$V_{CC} = 6.0$ V	-	6	13	-	16	-	19	ns
$t_w$	pulse width	$\overline{nCP}$ input, HIGH or LOW; see <a href="#">Figure 5</a>								
		$V_{CC} = 2.0$ V	80	22	-	100	-	120	-	ns
		$V_{CC} = 4.5$ V	16	8	-	20	-	24	-	ns
		$V_{CC} = 6.0$ V	14	6	-	17	-	20	-	ns
		$\overline{nR}$ input, HIGH or LOW; see <a href="#">Figure 6</a>								
		$V_{CC} = 2.0$ V	80	22	-	100	-	120	-	ns
		$V_{CC} = 4.5$ V	16	8	-	20	-	24	-	ns
$V_{CC} = 6.0$ V	14	6	-	17	-	20	-	ns		
$t_{rec}$	recovery time	$\overline{nR}$ to $\overline{nCP}$ ; see <a href="#">Figure 6</a>								
		$V_{CC} = 2.0$ V	60	19	-	75	-	90	-	ns
		$V_{CC} = 4.5$ V	12	7	-	15	-	18	-	ns
		$V_{CC} = 6.0$ V	20	6	-	13	-	15	-	ns
$t_{su}$	set-up time	nJ, nK to $\overline{nCP}$ ; see <a href="#">Figure 5</a>								
		$V_{CC} = 2.0$ V	100	22	-	125	-	150	-	ns
		$V_{CC} = 4.5$ V	20	8	-	25	-	30	-	ns
		$V_{CC} = 6.0$ V	17	6	-	21	-	26	-	ns

**Table 7. Dynamic characteristics ...continued**  
 GND (ground = 0 V);  $C_L = 50$  pF unless otherwise specified; for test circuit, see [Figure 7](#)

Symbol	Parameter	Conditions	25 °C			-40 °C to +85 °C		-40 °C to +125 °C		Unit
			Min	Typ	Max	Min	Max	Min	Max	
$t_h$	hold time	nJ, nK to $\overline{nCP}$ ; see <a href="#">Figure 5</a>								
		$V_{CC} = 2.0$ V	3	-6	-	3	-	3	-	ns
		$V_{CC} = 4.5$ V	3	-2	-	3	-	3	-	ns
		$V_{CC} = 6.0$ V	3	-2	-	3	-	3	-	ns
$f_{max}$	maximum frequency	$\overline{nCP}$ input; see <a href="#">Figure 5</a>								
		$V_{CC} = 2.0$ V	6	23	-	4.8	-	4.0	-	MHz
		$V_{CC} = 4.5$ V	30	70	-	24	-	20	-	MHz
		$V_{CC} = 5.0$ V; $C_L = 15$ pF	-	78	-	-	-	-	-	MHz
		$V_{CC} = 6.0$ V	35	85	-	28	-	24	-	MHz
$C_{PD}$	power dissipation capacitance	per flip-flop; $V_I = GND$ to $V_{CC}$ <a href="#">[3]</a>	-	30	-	-	-	-	-	pF
<b>74HCT107</b>										
$t_{pd}$	propagation delay	$\overline{nCP}$ to nQ; see <a href="#">Figure 5</a> <a href="#">[1]</a>								
		$V_{CC} = 4.5$ V	-	19	36	-	45	-	54	ns
		$V_{CC} = 5.0$ V; $C_L = 15$ pF	-	16	-	-	-	-	-	ns
		$\overline{nCP}$ to $\overline{nQ}$ ; see <a href="#">Figure 5</a>								
		$V_{CC} = 4.5$ V	-	21	36	-	45	-	54	ns
		$V_{CC} = 5.0$ V; $C_L = 15$ pF	-	18	-	-	-	-	-	ns
		$\overline{nR}$ to nQ, $\overline{nQ}$ ; see <a href="#">Figure 6</a>								
		$V_{CC} = 4.5$ V	-	20	38	-	48	-	57	ns
		$V_{CC} = 5.0$ V; $C_L = 15$ pF	-	17	-	-	-	-	-	ns
$t_t$	transition time	nQ, $\overline{nQ}$ ; see <a href="#">Figure 5</a> <a href="#">[2]</a>								
		$V_{CC} = 4.5$ V	-	7	15	-	19	-	22	ns
$t_w$	pulse width	$\overline{nCP}$ input, HIGH or LOW; see <a href="#">Figure 5</a>								
		$V_{CC} = 4.5$ V	16	9	-	20	-	24	-	ns
		$\overline{nR}$ input, HIGH or LOW; see <a href="#">Figure 6</a>								
		$V_{CC} = 4.5$ V	20	11	-	25	-	30	-	ns
$t_{rec}$	recovery time	$\overline{nR}$ to $\overline{nCP}$ ; see <a href="#">Figure 6</a>								
		$V_{CC} = 4.5$ V	14	8	-	18	-	21	-	ns
$t_{su}$	set-up time	nJ, nK to $\overline{nCP}$ ; see <a href="#">Figure 5</a>								
		$V_{CC} = 4.5$ V	20	7	-	25	-	30	-	ns
$t_h$	hold time	nJ, nK to $\overline{nCP}$ ; see <a href="#">Figure 5</a>								
		$V_{CC} = 4.5$ V	5	-2	-	5	-	5	-	ns

**Table 7. Dynamic characteristics ...continued**

GND (ground = 0 V);  $C_L = 50 \text{ pF}$  unless otherwise specified; for test circuit, see [Figure 7](#)

Symbol	Parameter	Conditions	25 °C			-40 °C to +85 °C		-40 °C to +125 °C		Unit
			Min	Typ	Max	Min	Max	Min	Max	
$f_{\text{max}}$	maximum frequency	nCP input; see <a href="#">Figure 5</a>								
		$V_{\text{CC}} = 4.5 \text{ V}$	30	66	-	24	-	20	-	MHz
		$V_{\text{CC}} = 5.0 \text{ V}; C_L = 15 \text{ pF}$	-	73	-	-	-	-	-	MHz
$C_{\text{PD}}$	power dissipation capacitance	per flip-flop; $V_I = \text{GND to } V_{\text{CC}} - 1.5 \text{ V}$ <a href="#">[3]</a>	-	30	-	-	-	-	-	pF

- [1]  $t_{\text{pd}}$  is the same as  $t_{\text{PHL}}, t_{\text{PLH}}$ .
- [2]  $t_t$  is the same as  $t_{\text{THL}}, t_{\text{TLH}}$ .
- [3]  $C_{\text{PD}}$  is used to determine the dynamic power dissipation ( $P_D$  in  $\mu\text{W}$ ).  
 $P_D = C_{\text{PD}} \times V_{\text{CC}}^2 \times f_i \times N + \sum(C_L \times V_{\text{CC}}^2 \times f_o)$  where:  
 $f_i$  = input frequency in MHz;  
 $f_o$  = output frequency in MHz;  
 $C_L$  = output load capacitance in pF;  
 $V_{\text{CC}}$  = supply voltage in V;  
 $N$  = number of inputs switching;  
 $\sum(C_L \times V_{\text{CC}}^2 \times f_o)$  = sum of outputs.

## 11. Waveforms

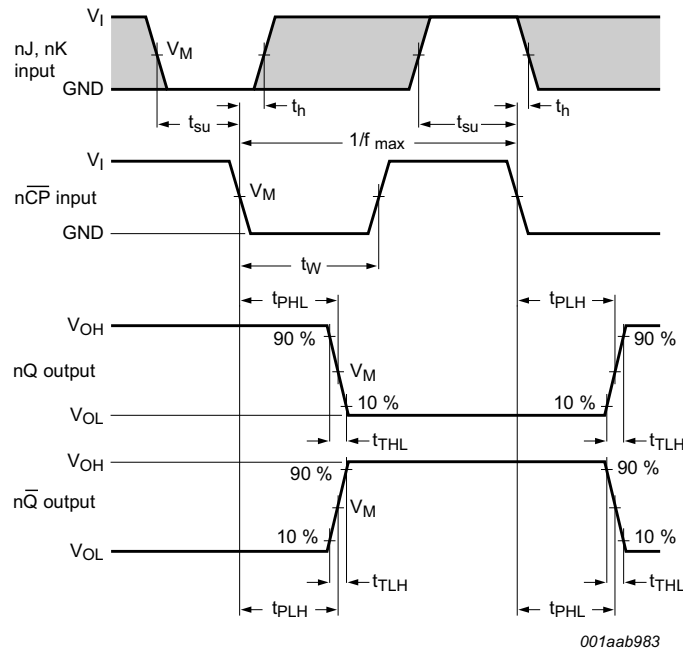

The shaded areas indicate when the input is permitted to change for predictable output performance.

Measurement points are given in [Table 8](#).

$V_{\text{OL}}$  and  $V_{\text{OH}}$  are typical voltage output levels that occur with the output load.

**Fig 5. Clock propagation delays, pulse width, set-up and hold times, output transition times and the maximum frequency**

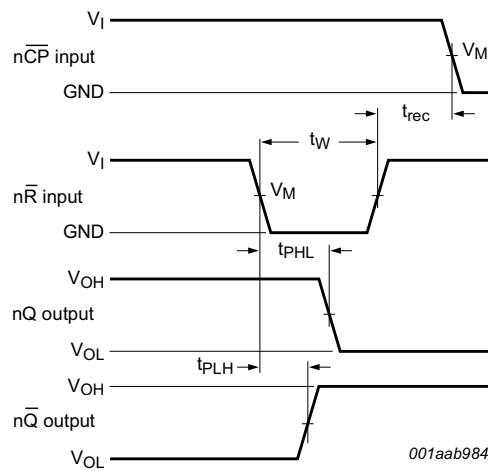

Measurement points are given in [Table 8](#).

$V_{OL}$  and  $V_{OH}$  are typical voltage output levels that occur with the output load.

**Fig 6. Reset propagation delays, pulse width and recovery time**

**Table 8. Measurement points**

Type	Input		Output
	$V_I$	$V_M$	$V_M$
74HC107	$V_{CC}$	$0.5V_{CC}$	$0.5V_{CC}$
74HCT107	3 V	1.3 V	1.3 V

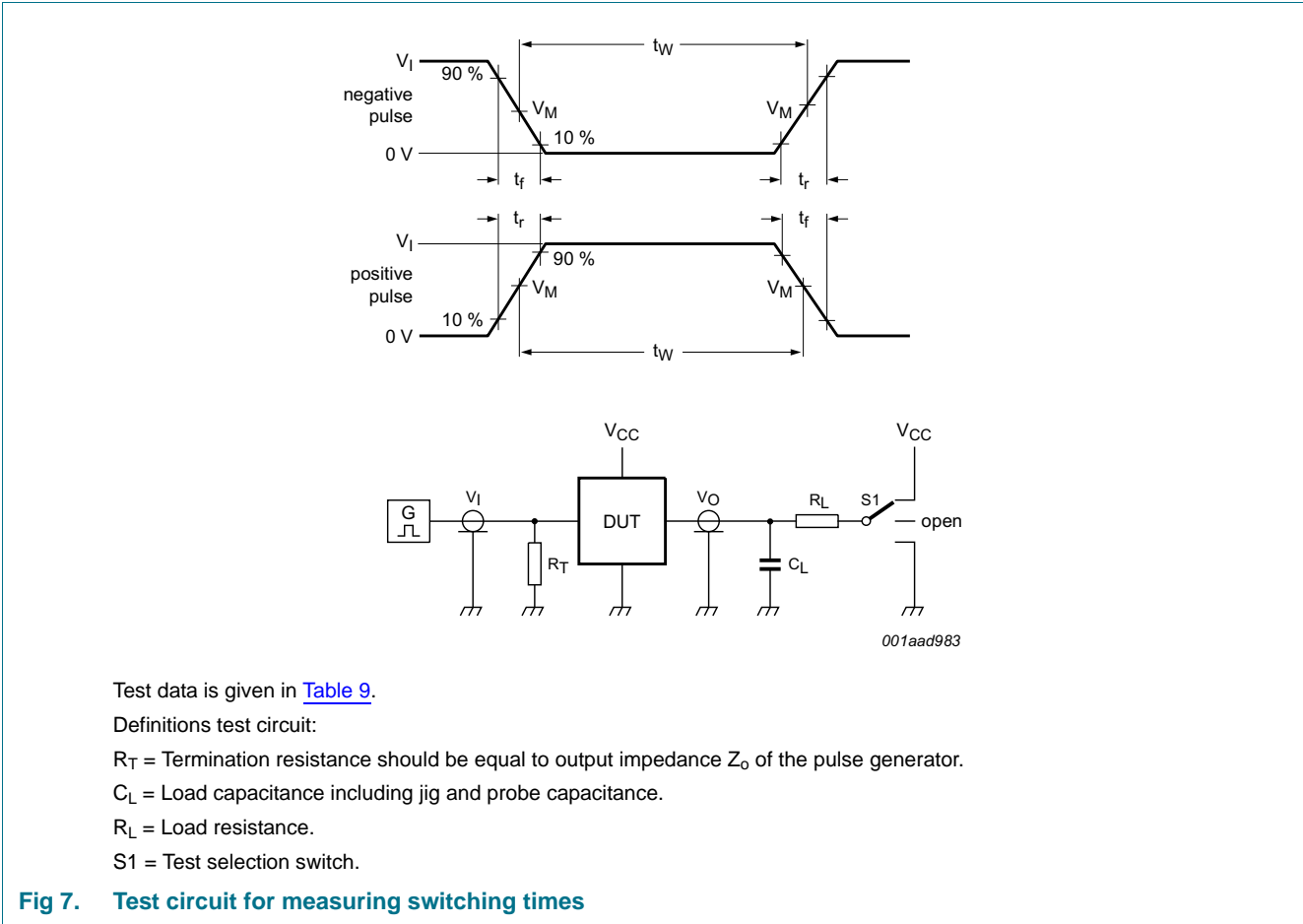

Table 9. Test data

Type	Input		Load		S1 position		
	$V_I$	$t_r, t_f$	$C_L$	$R_L$	$t_{PHL}, t_{PLH}$	$t_{PZH}, t_{PHZ}$	$t_{PZL}, t_{PLZ}$
74HC107	$V_{CC}$	6 ns	15 pF, 50 pF	1 k $\Omega$	open	GND	$V_{CC}$
74HCT107	3 V	6 ns	15 pF, 50 pF	1 k $\Omega$	open	GND	$V_{CC}$

12. Package outline

DIP14: plastic dual in-line package; 14 leads (300 mil)

SOT27-1

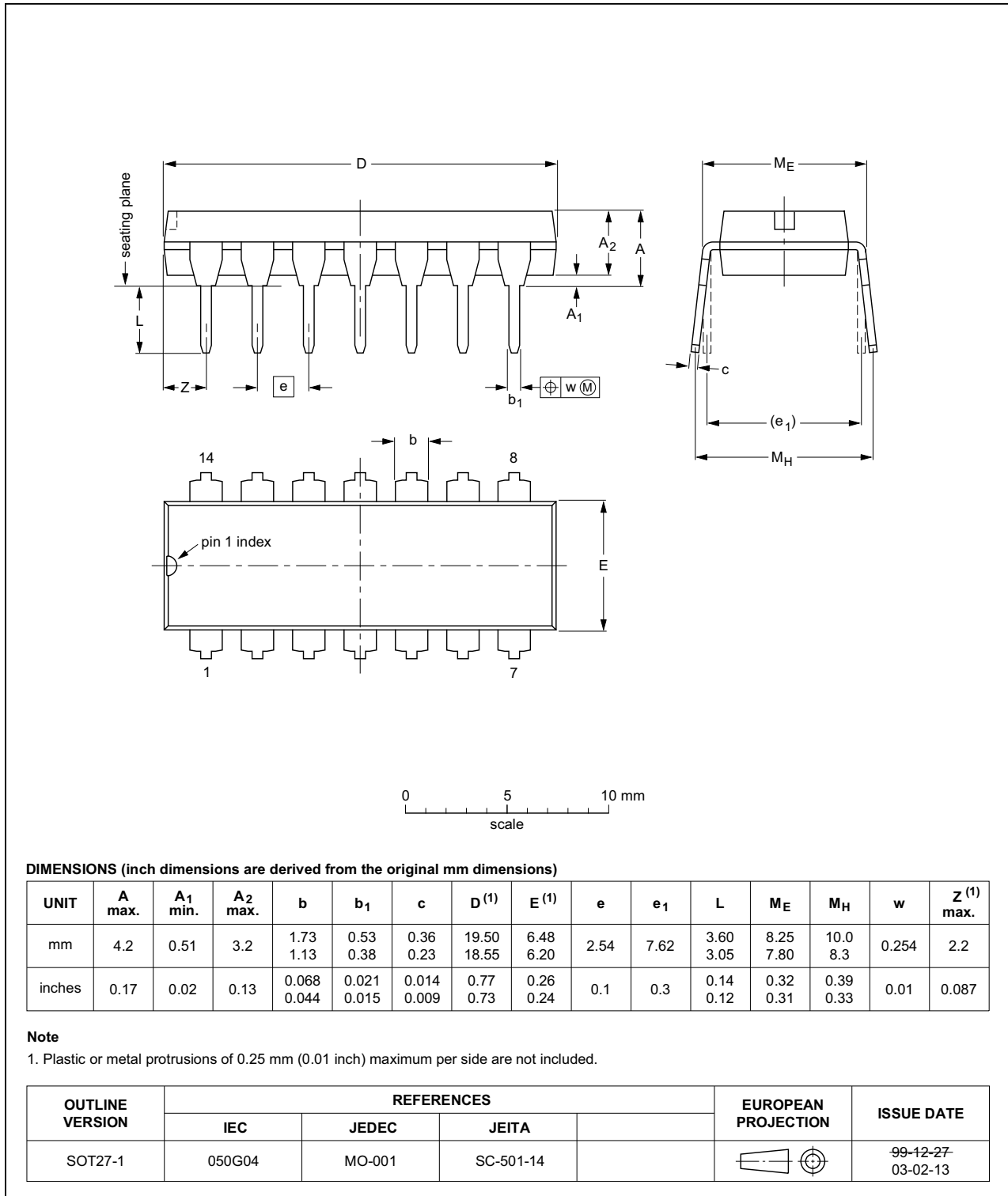

Fig 8. Package outline SOT27-1 (DIP14)

SO14: plastic small outline package; 14 leads; body width 3.9 mm

SOT108-1

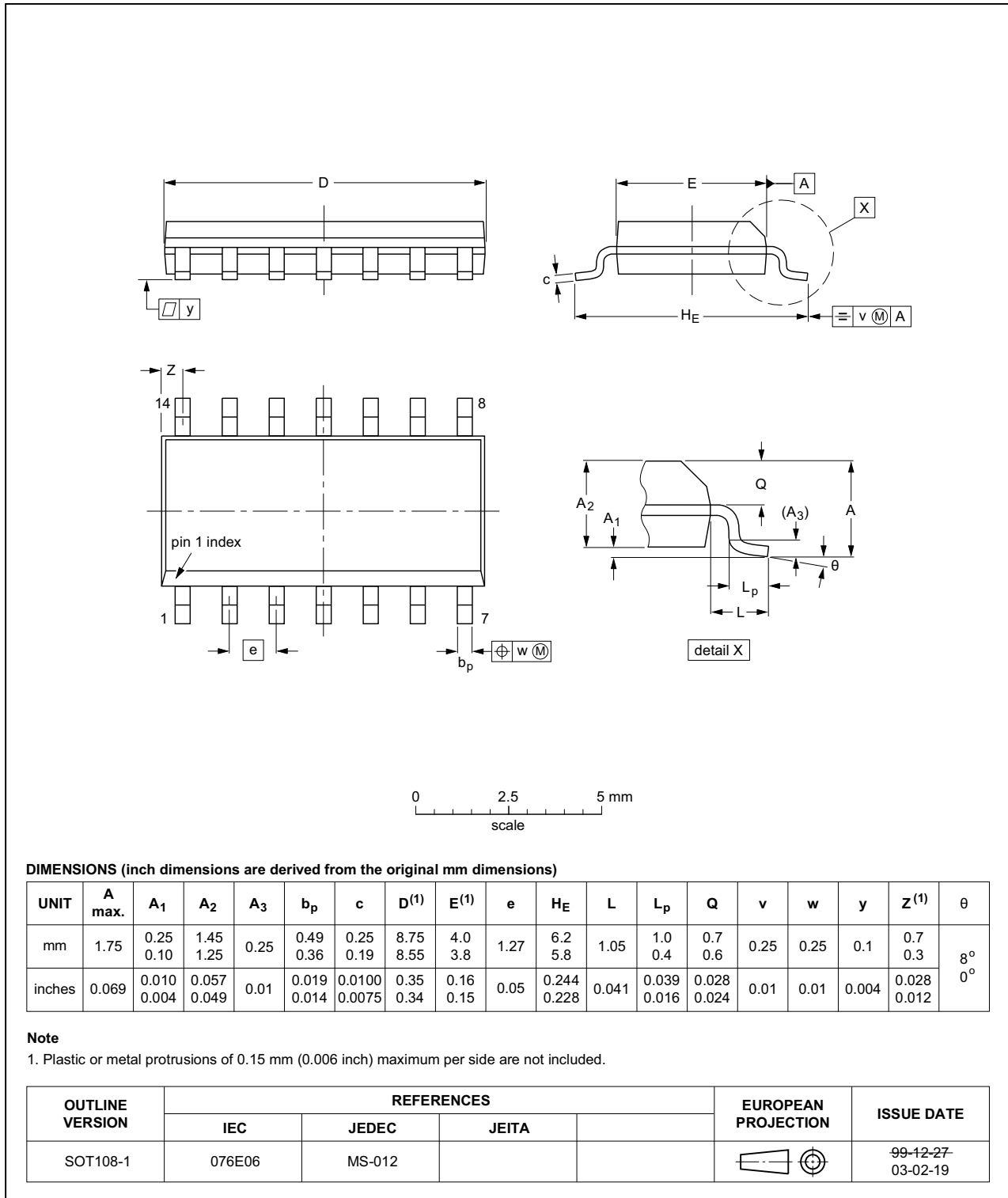

Fig 9. Package outline SOT108-1 (SO14)

SSOP14: plastic shrink small outline package; 14 leads; body width 5.3 mm

SOT337-1

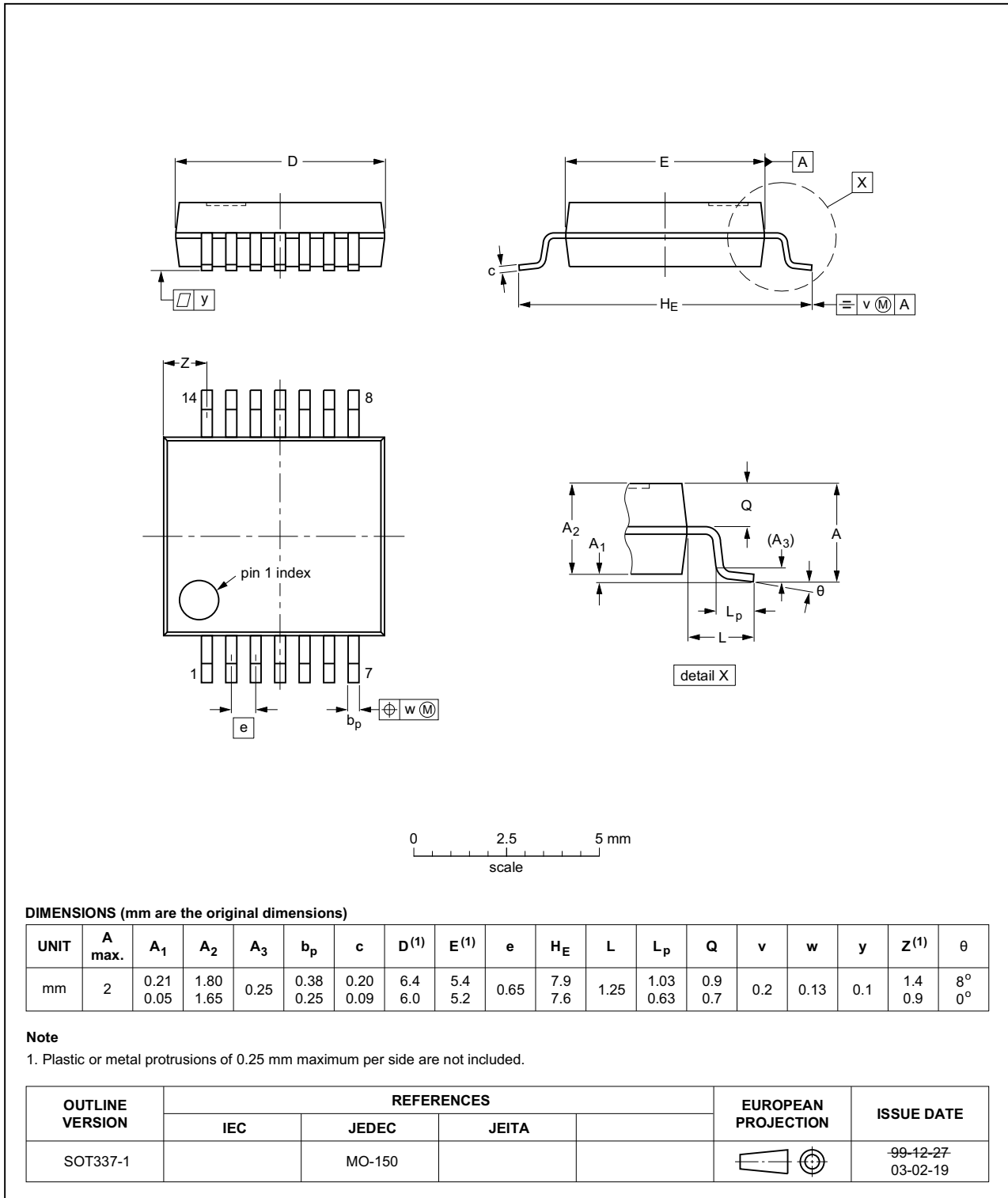

Fig 10. Package outline SOT337-1 (SSOP14)

TSSOP14: plastic thin shrink small outline package; 14 leads; body width 4.4 mm

SOT402-1

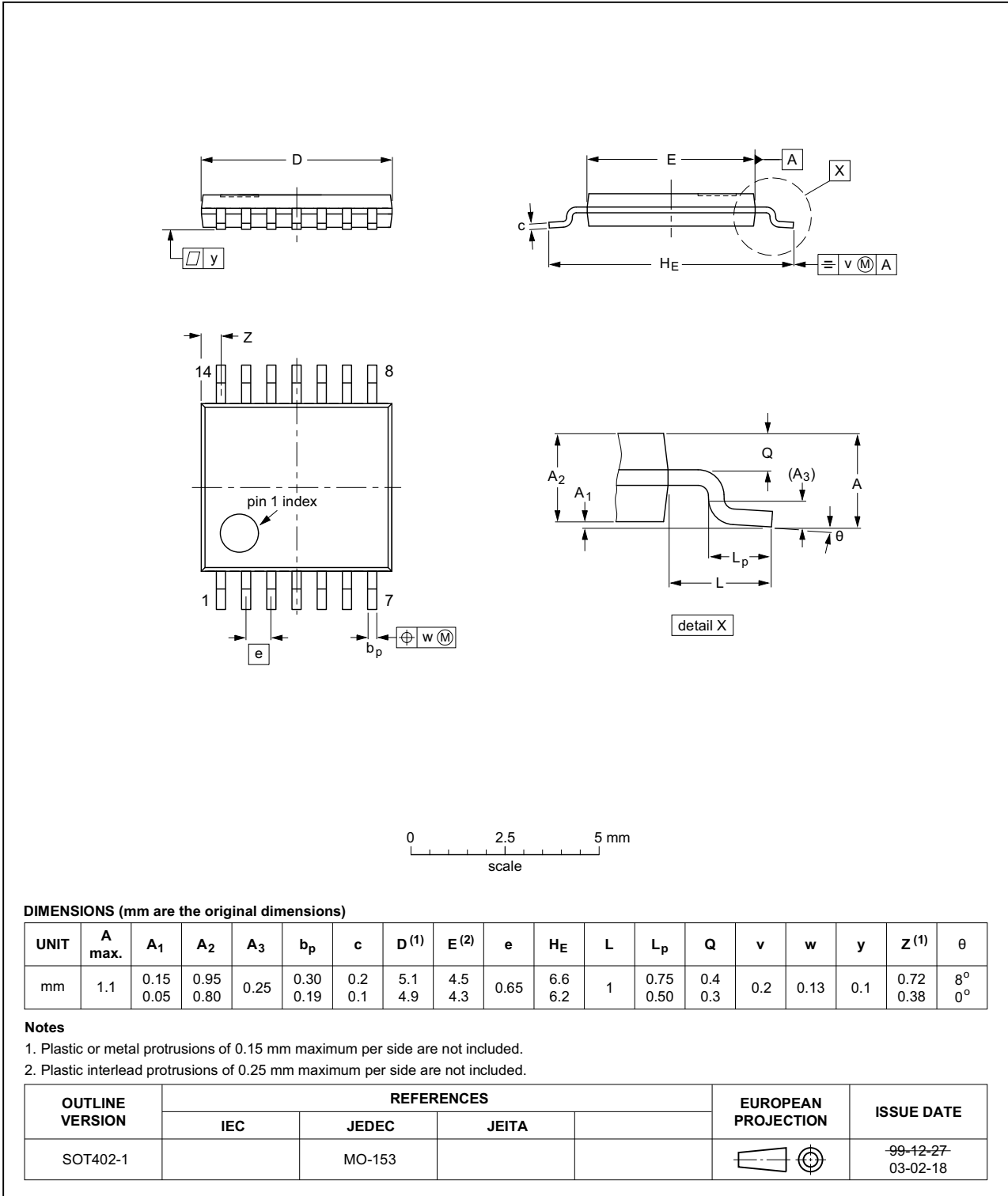

Fig 11. Package outline SOT402-1 (TSSOP14)

## 13. Abbreviations

Table 10. Abbreviations

Acronym	Description
CMOS	Complementary Metal Oxide Semiconductor
LSTTL	Low-power Schottky Transistor-Transistor Logic
ESD	ElectroStatic Discharge
HBM	Human Body Model
MM	Machine Model
CDM	Charge-Device Model
TTL	Transistor-Transistor Logic

## 14. Revision history

Table 11. Revision history

Document ID	Release date	Data sheet status	Change notice	Supersedes
74HC_HCT107 v.4	20150126	Product data sheet	-	74HC_HCT107 v.3
Modifications:	<ul style="list-style-type: none"> <li>• <a href="#">Table 7</a>: Power dissipation capacitance condition for 74HCT107 is corrected.</li> </ul>			
74HC_HCT107 v.3	20131118	Product data sheet	-	74HC_HCT107_CNV v.2
Modifications:	<ul style="list-style-type: none"> <li>• The format of this data sheet has been redesigned to comply with the new identity guidelines of NXP Semiconductors.</li> <li>• Legal texts have been adapted to the new company name where appropriate.</li> </ul>			
74HC_HCT107_CNV v.2	19901201	Product specification	-	-

## 15. Legal information

### 15.1 Data sheet status

Document status <sup>[1][2]</sup>	Product status <sup>[3]</sup>	Definition
Objective [short] data sheet	Development	This document contains data from the objective specification for product development.
Preliminary [short] data sheet	Qualification	This document contains data from the preliminary specification.
Product [short] data sheet	Production	This document contains the product specification.

[1] Please consult the most recently issued document before initiating or completing a design.

[2] The term 'short data sheet' is explained in section "Definitions".

[3] The product status of device(s) described in this document may have changed since this document was published and may differ in case of multiple devices. The latest product status information is available on the Internet at URL <http://www.nxp.com>.

### 15.2 Definitions

**Draft** — The document is a draft version only. The content is still under internal review and subject to formal approval, which may result in modifications or additions. NXP Semiconductors does not give any representations or warranties as to the accuracy or completeness of information included herein and shall have no liability for the consequences of use of such information.

**Short data sheet** — A short data sheet is an extract from a full data sheet with the same product type number(s) and title. A short data sheet is intended for quick reference only and should not be relied upon to contain detailed and full information. For detailed and full information see the relevant full data sheet, which is available on request via the local NXP Semiconductors sales office. In case of any inconsistency or conflict with the short data sheet, the full data sheet shall prevail.

**Product specification** — The information and data provided in a Product data sheet shall define the specification of the product as agreed between NXP Semiconductors and its customer, unless NXP Semiconductors and customer have explicitly agreed otherwise in writing. In no event however, shall an agreement be valid in which the NXP Semiconductors product is deemed to offer functions and qualities beyond those described in the Product data sheet.

### 15.3 Disclaimers

**Limited warranty and liability** — Information in this document is believed to be accurate and reliable. However, NXP Semiconductors does not give any representations or warranties, expressed or implied, as to the accuracy or completeness of such information and shall have no liability for the consequences of use of such information. NXP Semiconductors takes no responsibility for the content in this document if provided by an information source outside of NXP Semiconductors.

In no event shall NXP Semiconductors be liable for any indirect, incidental, punitive, special or consequential damages (including - without limitation - lost profits, lost savings, business interruption, costs related to the removal or replacement of any products or rework charges) whether or not such damages are based on tort (including negligence), warranty, breach of contract or any other legal theory.

Notwithstanding any damages that customer might incur for any reason whatsoever, NXP Semiconductors' aggregate and cumulative liability towards customer for the products described herein shall be limited in accordance with the *Terms and conditions of commercial sale* of NXP Semiconductors.

**Right to make changes** — NXP Semiconductors reserves the right to make changes to information published in this document, including without limitation specifications and product descriptions, at any time and without notice. This document supersedes and replaces all information supplied prior to the publication hereof.

**Suitability for use** — NXP Semiconductors products are not designed, authorized or warranted to be suitable for use in life support, life-critical or safety-critical systems or equipment, nor in applications where failure or malfunction of an NXP Semiconductors product can reasonably be expected to result in personal injury, death or severe property or environmental damage. NXP Semiconductors and its suppliers accept no liability for inclusion and/or use of NXP Semiconductors products in such equipment or applications and therefore such inclusion and/or use is at the customer's own risk.

**Applications** — Applications that are described herein for any of these products are for illustrative purposes only. NXP Semiconductors makes no representation or warranty that such applications will be suitable for the specified use without further testing or modification.

Customers are responsible for the design and operation of their applications and products using NXP Semiconductors products, and NXP Semiconductors accepts no liability for any assistance with applications or customer product design. It is customer's sole responsibility to determine whether the NXP Semiconductors product is suitable and fit for the customer's applications and products planned, as well as for the planned application and use of customer's third party customer(s). Customers should provide appropriate design and operating safeguards to minimize the risks associated with their applications and products.

NXP Semiconductors does not accept any liability related to any default, damage, costs or problem which is based on any weakness or default in the customer's applications or products, or the application or use by customer's third party customer(s). Customer is responsible for doing all necessary testing for the customer's applications and products using NXP Semiconductors products in order to avoid a default of the applications and the products or of the application or use by customer's third party customer(s). NXP does not accept any liability in this respect.

**Limiting values** — Stress above one or more limiting values (as defined in the Absolute Maximum Ratings System of IEC 60134) will cause permanent damage to the device. Limiting values are stress ratings only and (proper) operation of the device at these or any other conditions above those given in the Recommended operating conditions section (if present) or the Characteristics sections of this document is not warranted. Constant or repeated exposure to limiting values will permanently and irreversibly affect the quality and reliability of the device.

**Terms and conditions of commercial sale** — NXP Semiconductors products are sold subject to the general terms and conditions of commercial sale, as published at <http://www.nxp.com/profile/terms>, unless otherwise agreed in a valid written individual agreement. In case an individual agreement is concluded only the terms and conditions of the respective agreement shall apply. NXP Semiconductors hereby expressly objects to applying the customer's general terms and conditions with regard to the purchase of NXP Semiconductors products by customer.

**No offer to sell or license** — Nothing in this document may be interpreted or construed as an offer to sell products that is open for acceptance or the grant, conveyance or implication of any license under any copyrights, patents or other industrial or intellectual property rights.

**Export control** — This document as well as the item(s) described herein may be subject to export control regulations. Export might require a prior authorization from competent authorities.

**Non-automotive qualified products** — Unless this data sheet expressly states that this specific NXP Semiconductors product is automotive qualified, the product is not suitable for automotive use. It is neither qualified nor tested in accordance with automotive testing or application requirements. NXP Semiconductors accepts no liability for inclusion and/or use of non-automotive qualified products in automotive equipment or applications.

In the event that customer uses the product for design-in and use in automotive applications to automotive specifications and standards, customer (a) shall use the product without NXP Semiconductors' warranty of the product for such automotive applications, use and specifications, and (b) whenever customer uses the product for automotive applications beyond

NXP Semiconductors' specifications such use shall be solely at customer's own risk, and (c) customer fully indemnifies NXP Semiconductors for any liability, damages or failed product claims resulting from customer design and use of the product for automotive applications beyond NXP Semiconductors' standard warranty and NXP Semiconductors' product specifications.

**Translations** — A non-English (translated) version of a document is for reference only. The English version shall prevail in case of any discrepancy between the translated and English versions.

## 15.4 Trademarks

Notice: All referenced brands, product names, service names and trademarks are the property of their respective owners.

## 16. Contact information

For more information, please visit: <http://www.nxp.com>

For sales office addresses, please send an email to: [salesaddresses@nxp.com](mailto:salesaddresses@nxp.com)

## 17. Contents

<b>1</b>	<b>General description</b> .....	<b>1</b>
<b>2</b>	<b>Features and benefits</b> .....	<b>1</b>
<b>3</b>	<b>Ordering information</b> .....	<b>1</b>
<b>4</b>	<b>Functional diagram</b> .....	<b>2</b>
<b>5</b>	<b>Pinning information</b> .....	<b>3</b>
5.1	Pinning .....	3
5.2	Pin description .....	3
<b>6</b>	<b>Functional description</b> .....	<b>4</b>
<b>7</b>	<b>Limiting values</b> .....	<b>4</b>
<b>8</b>	<b>Recommended operating conditions</b> .....	<b>5</b>
<b>9</b>	<b>Static characteristics</b> .....	<b>5</b>
<b>10</b>	<b>Dynamic characteristics</b> .....	<b>7</b>
<b>11</b>	<b>Waveforms</b> .....	<b>9</b>
<b>12</b>	<b>Package outline</b> .....	<b>12</b>
<b>13</b>	<b>Abbreviations</b> .....	<b>16</b>
<b>14</b>	<b>Revision history</b> .....	<b>16</b>
<b>15</b>	<b>Legal information</b> .....	<b>17</b>
15.1	Data sheet status .....	17
15.2	Definitions .....	17
15.3	Disclaimers .....	17
15.4	Trademarks .....	18
<b>16</b>	<b>Contact information</b> .....	<b>18</b>
<b>17</b>	<b>Contents</b> .....	<b>19</b>

Please be aware that important notices concerning this document and the product(s) described herein, have been included in section 'Legal information'.



© NXP Semiconductors N.V. 2015. All rights reserved.

For more information, please visit: <http://www.nxp.com>  
 For sales office addresses, please send an email to: [salesaddresses@nxp.com](mailto:salesaddresses@nxp.com)

Date of release: 26 January 2015  
 Document identifier: 74HC\_HCT107

## Looking for pricing, stock, or lifecycle information?

Click below to explore more details on WIN SOURCE:

-  [View 74HCT107N on WIN SOURCE](#)
-  [NXP / Nexperia Information](#)

## Optimize Your Supply Chain with WIN SOURCE Solutions

-  Global Sourcing Solution
-  Obsolete Management
-  Cost Control Management
-  Shortage Management
-  Alternative Solution
-  Excess Inventory Management