



**THE DATASHEET OF  
SN75LBC180ADR**



# SNx5LBC180A Low-Power Differential Line Driver and Receiver Pairs

## 1 Features

- High-speed low-power LinBICMOS™ circuitry designed for signaling rates<sup>(1)</sup> of up to 30 Mbps
- Bus-Pin ESD protection 15 kV HBM
- Low disabled supply-current requirements: 700  $\mu$ A maximum
- Designed for high-speed multipoint data transmission over long cables
- Common-mode voltage range of  $-7$  V to 12 V
- Low supply current: 15 mA Max
- Compatible with ANSI standard TIA/EIA-485-A and ISO 8482:1987(E)
- Positive and negative output current limiting
- Driver thermal shutdown protection <sup>1</sup>

## 2 Description

The SN65LBC180A and SN75LBC180A differential driver and receiver pairs are monolithic integrated circuits designed for bidirectional data communication over long cables that take on the characteristics of transmission lines. They are balanced, or differential, voltage mode devices that are compatible with ANSI standard TIA/EIA-485-A and ISO 8482:1987(E). The A version offers improved switching performance over

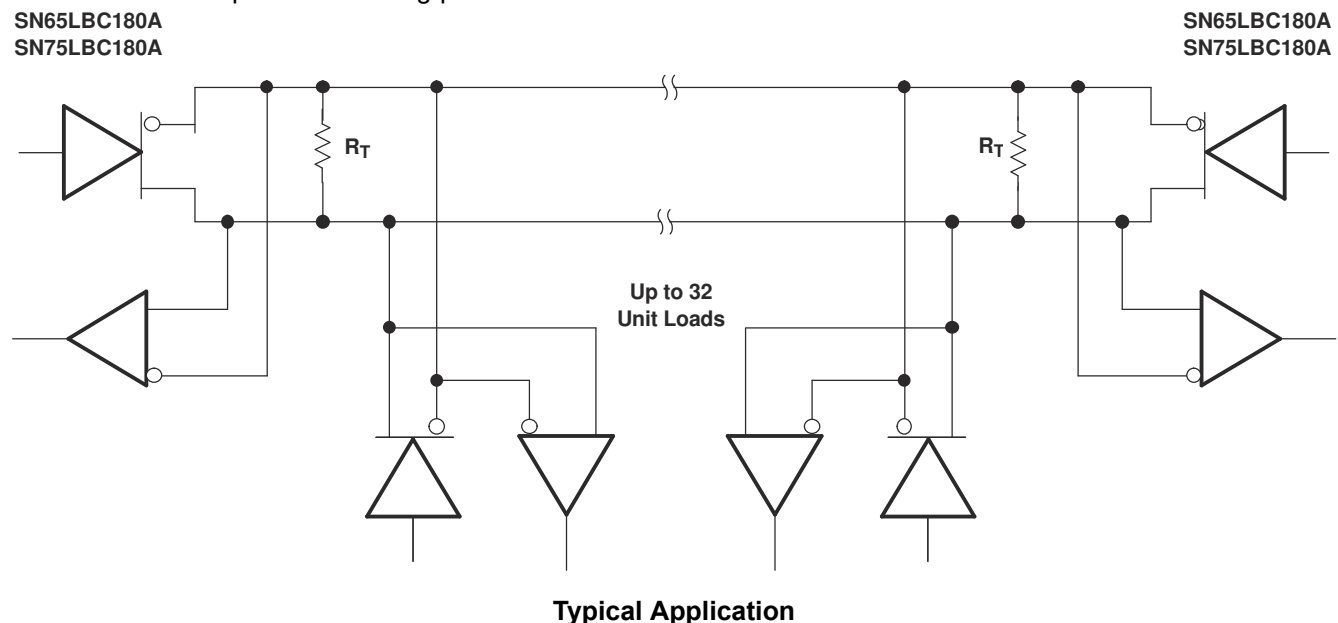
its predecessors without sacrificing significantly more power.

These devices combine a differential line driver and differential input line receiver and operate from a single 5-V power supply. The driver differential outputs and the receiver differential inputs are connected to separate terminals for full-duplex operation and are designed to present minimum loading to the bus when powered off ( $V_{CC} = 0$ ). These parts feature wide positive and negative common-mode voltage ranges, making them suitable for point-to-point or multipoint data bus applications. The devices also provide positive and negative current limiting for protection from line fault conditions. The SN65LBC180A is characterized for operation from  $-40^{\circ}\text{C}$  to  $85^{\circ}\text{C}$ , and the SN75LBC180A is characterized for operation from  $0^{\circ}\text{C}$  to  $70^{\circ}\text{C}$ .

### Package Information

PART NUMBER	PACKAGE <sup>(1)</sup>	BODY SIZE (NOM)
SN65LBC180ASN75LBC180A	D (SOIC)	4.9 mm x 3.91 mm
	N (PDIP)	9.81 mm x 6.35 mm

(1) For all available packages, see the orderable addendum at the end of the data sheet.



<sup>1</sup> Signaling rate by TIA/EIA-485-A definition restrict transition times to 30% of the bit duration, and much higher signaling rates may be achieved without this requirement as displayed in the *Typical Characteristics* of this device.



### 3 Revision History

NOTE: Page numbers for previous revisions may differ from page numbers in the current version.

---

<b>Changes from Revision D (April 2009) to Revision E (January 2023)</b>	<b>Page</b>
• Changed the document to the latest TI format.....	1
• Added the <i>Pin Configuration and Functions</i> .....	3
• Added the <i>Thermal Information</i> table.....	5
• Changed the Typical Characteristics graphs.....	7

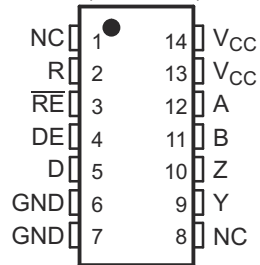
---

<b>Changes from Revision C (June 2002) to Revision D (April 2009)</b>	<b>Page</b>
• Deleted exceeds from features, and changed 12 kV To 15 kV.....	1
• Deleted storage temperature and lead temperature from the absolute maximum ratings table.....	4
• Added receiver output current to the absolute maximum ratings table.....	4
• Changed the ESD rows in the absolute maximum ratings table.....	4

---

## 4 Pin Configuration and Functions

SN65LBC180AD (Marked as BL180A)  
 SN65LBC180AN (Marked as 65LBC180A)  
 SN75LBC180AD (Marked as LB180A)  
 SN75LBC180AN (Marked as 75LBC180A)  
 (TOP VIEW)



NC – No internal connection  
 Pins 6 and 7 are connected together internally  
 Pins 13 and 14 are connected together internally

**Table 4-1. Pin Functions**

PIN		TYPE	DESCRIPTION
NAME	NO.		
NC	1, 8	No Connect	Not electrically connected
R	2	Digital Output	Logic output RS485 data
RE	3	Digital Input	Receiver enable, active low
DE	4	Digital Input	Driver enable, active high
D	5	Digital Input	Driver data input
GND	6, 7	Ground	Device ground
Y	9	Bus Output	Bus Output Y (Complementary to Z)
Z	10	Bus Output	Bus Output Z (Complementary to Y)
B	11	Bus Input	Bus Input B (Complementary to A)
A	12	Bus Input	Bus Input A (Complementary to B)
V <sub>CC</sub>	13, 14	Power	5 V Supply

## 5 Reference

### 5.1 Absolute Maximum Ratings

over operating free-air temperature range (unless otherwise noted) <sup>(1)</sup>

			UNIT
V <sub>CC</sub>	Supply voltage range <sup>(2)</sup>		–0.3 V to 6 V
V <sub>I</sub>	Input voltage range	A, B	–10 V to 15 V
	Voltage range	D, R, DE, RE	–0.3 V to V <sub>CC</sub> + 0.5 V
I <sub>O</sub>	Receiver output current		±10 mA
	Continuous total power dissipation <sup>(3)</sup>		Internally limited
	Total power dissipation		See Dissipation Rating Table
ESD	Bus terminals and GND	HBM (Human Body Model) EIA/JESD22-A114 <sup>(4)</sup>	±15 kV
	All pins	HBM (Human Body Model) EIA/JESD22-A114 <sup>(4)</sup>	±3 kV
		MM (Machine Model) EIA/JESD22-A115	±400 V
		CDM (Charge Device Model) EIA/JESD22-C101	±1.5 kV

- (1) Stresses beyond those listed under *absolute maximum ratings* may cause permanent damage to the device. These are stress ratings only, and functional operation of the device at these or any other conditions beyond those indicated under *recommended operating conditions* is not implied. Exposure to absolute-maximum-rated conditions for extended periods may affect device reliability.
- (2) All voltage values are with respect to GND except for differential input or output voltages.
- (3) The maximum operating junction temperature is internally limited. Use the dissipation rating table to operate below this temperature.
- (4) Tested in accordance with MIL-STD-883C, Method 3015.7.

### 5.2 Dissipation Ratings

PACKAGE	T <sub>A</sub> ≤ 25°C POWER RATING	DERATING FACTOR <sup>(1)</sup> ABOVE T <sub>A</sub> = 25°C	T <sub>A</sub> = 70°C POWER RATING	T <sub>A</sub> = 85°C POWER RATING
D	950 mW	7.6 mW/°C	608 mW	494 mW
N	1150 mW	9.2 mW/°C	736 mW	598 mW

- (1) This is the inverse of the junction-to-ambient thermal resistance when board-mounted and with no air flow.

### 5.3 RECOMMENDED OPERATING CONDITIONS

			MIN	NOM	MAX	UNIT
V <sub>CC</sub>	Supply voltage		4.75	5	5.25	V
V <sub>IH</sub>	High-level input voltage	D, DE, and RE	2		V <sub>CC</sub>	V
V <sub>IL</sub>	Low-level input voltage	D, DE, and RE	0		0.8	V
V <sub>ID</sub>	Differential input voltage <sup>(1)</sup>		–12 <sup>(2)</sup>		12	V
V <sub>O</sub>	Voltage at any bus terminal (separately or common mode)	A, B, Y, or Z	–7		12	V
V <sub>I</sub>						
V <sub>IC</sub>						
I <sub>OH</sub>	High-level output current	Y or Z	–60			mA
		R	–8			
I <sub>OL</sub>	Low-level output current	Y or Z			60	mA
		R			8	
T <sub>A</sub>	Operating free-air temperature	SN65LBC180A	–40		85	°C
		SN75LBC180A	0		70	

- (1) Differential input/output bus voltage is measured at the noninverting terminal with respect to the inverting terminal.
- (2) The algebraic convention, where the least positive (more negative) limit is designated minimum, is used in this data sheet.

## 5.4 Thermal Information

THERMAL METRIC <sup>(1)</sup>		N (PDIP)	D (SOIC) SN75 Devices	D (SOIC) SN65 Devices	UNIT
		14-Pins	14-Pins	14-Pins	
$R_{\theta JA}$	Junction-to-ambient thermal resistance	54.2	88.6	93.2	°C/W
$R_{\theta JB}$	Junction-to-board thermal resistance	41.6	49.12	49.4	°C/W
$\Psi_{JT}$	Junction-to-top characterization parameter	34.0	14.17	11.2	°C/W
$\Psi_{JB}$	Junction-to-board characterization parameter	21.1	48.6	48.9	°C/W
$R_{\theta JC(bot)}$	Junction-to-case (bottom) thermal resistance	N/A	N/A	N/A	°C/W

(1) For more information about traditional and new thermal metrics, see the [Semiconductor and IC package thermal metrics](#) application report.

## 5.5 Driver Electrical Characteristics

over recommended operating conditions (unless otherwise noted)

PARAMETER		TEST CONDITIONS		MIN	TYP <sup>(1)</sup>	MAX	UNIT
$V_{IK}$	Input clamp voltage	$I_I = -18 \text{ mA}$		-1.5	-0.8		V
$ V_{OD} $	Differential output voltage magnitude	$R_L = 54 \Omega$ , See <a href="#">Figure 6-1</a>	SN65LBC180A	1	1.5	3	V
			SN75LBC180A	1.1	1.5	3	
		$R_L = 60 \Omega$ , See <a href="#">Figure 6-2</a>	SN65LBC180A	1	1.5	3	V
			SN75LBC180A	1.1	1.5	3	
$\Delta  V_{OD} $	Change in magnitude of differential output voltage <sup>(2)</sup>	See <a href="#">Figure 6-1</a> and <a href="#">Figure 6-2</a>		-0.2		0.2	V
$V_{OC(ss)}$	Steady-state common-mode output voltage	See <a href="#">Figure 6-1</a>		1.8	2.4	2.8	V
$\Delta V_{OC}$	Change in steady-state common-mode output voltage <sup>(2)</sup>			-0.1		0.1	V
$I_O$	Output current with power off	$V_{CC} = 0$ ,	$V_O = -7 \text{ V to } 12 \text{ V}$	-10		10	$\mu\text{A}$
$I_{IH}$	High-level input current	$V_I = 2 \text{ V}$		-100			$\mu\text{A}$
$I_{IL}$	Low-level input current	$V_I = 0.8 \text{ V}$		-100			$\mu\text{A}$
$I_{OS}$	Short-circuit output current	$-7 \text{ V} \leq V_O \leq 12 \text{ V}$		-250	$\pm 70$	250	mA
$I_{CC}$	Supply current	$V_I = 0$ or $V_{CC}$ , No load	Receiver disabled and driver enabled		5.5	9	mA
			Receiver disabled and driver disabled		0.5	1	
			Receiver enabled and driver enabled		8.5	15	

(1) All typical values are at  $V_{CC} = 5 \text{ V}$ ,  $T_A = 25^\circ\text{C}$ .

(2)  $\Delta |V_{OD}|$  and  $\Delta |V_{OC}|$  are the changes in the steady-state magnitude of  $V_{OD}$  and  $V_{OC}$ , respectively, that occur when the input is changed from a high level to a low level.

## 5.6 Driver Switching Characteristics

over recommended operating conditions (unless otherwise noted)

PARAMETER		TEST CONDITIONS	MIN	TYP	MAX	UNIT
$t_{PLH}$	Propagation delay time, low-to-high-level output	$R_L = 54 \Omega$ , $C_L = 50 \text{ pF}$ , See <a href="#">Figure 6-3</a>	2	6	12	ns
$t_{PHL}$	Propagation delay time, high-to-low-level output		2	6	12	ns
$t_{sk(p)}$	Pulse skew ( $  t_{PLH} - t_{PHL}  $ )		0.3	1	ns	
$t_r$	Differential output signal rise time		4	7.5	11	ns
$t_f$	Differential output signal fall time		4	7.5	11	ns
$t_{PZH}$	Propagation delay time, high-impedance-to-high-level output	$R_L = 110 \Omega$ , See <a href="#">Figure 6-4</a>		12	22	ns
$t_{PZL}$	Propagation delay time, high-impedance-to-low-level output	$R_L = 110 \Omega$ , See <a href="#">Figure 6-5</a>		12	22	ns
$t_{PHZ}$	Propagation delay time, high-level-to-high-impedance output	$R_L = 110 \Omega$ , See <a href="#">Figure 6-4</a>		12	22	ns
$t_{PLZ}$	Propagation delay time, low-level-to-high-impedance output	$R_L = 110 \Omega$ , See <a href="#">Figure 6-5</a>		12	22	ns

## 5.7 Receiver Electrical Characteristics

over recommended operating conditions (unless otherwise noted)

PARAMETER		TEST CONDITIONS	MIN	TYP <sup>(1)</sup>	MAX	UNIT
$V_{IT+}$	Positive-going input threshold voltage	$I_O = -8 \text{ mA}$			0.2	V
$V_{IT-}$	Negative-going input threshold voltage	$I_O = 8 \text{ mA}$	-0.2			V
$V_{hys}$	Hysteresis voltage ( $V_{IT+} - V_{IT-}$ )			50		mV
$V_{IK}$	Enable-input clamp voltage	$I_I = -18 \text{ mA}$	-1.5	-0.8		V
$V_{OH}$	High-level output voltage	$V_{ID} = 200 \text{ mV}$ , $I_{OH} = -8 \text{ mA}$	4	4.9		V
$V_{OL}$	Low-level output voltage	$V_{ID} = -200 \text{ mV}$ , $I_{OL} = 8 \text{ mA}$		0.1	0.8	V
$I_{OZ}$	High-impedance-state output current	$V_O = 0 \text{ V to } V_{CC}$	-1		1	$\mu\text{A}$
$I_{IH}$	High-level enable-input current	$V_{IH} = 2.4 \text{ V}$	-100			$\mu\text{A}$
$I_{IL}$	Low-level enable-input current	$V_{IL} = 0.4 \text{ V}$	-100			$\mu\text{A}$
$I_I$	Bus input current	$V_I = 12 \text{ V}$ , $V_{CC} = 5 \text{ V}$		0.4	1	mA
		$V_I = 12 \text{ V}$ , $V_{CC} = 0$		0.5	1	
		$V_I = -7 \text{ V}$ , $V_{CC} = 5 \text{ V}$	Other input at 0 V	-0.8	-0.4	
		$V_I = -7 \text{ V}$ , $V_{CC} = 0$		-0.8	-0.3	
$I_{CC}$	Supply current	$V_I = 0$ or $V_{CC}$ , No load	Receiver enabled and driver disabled	4.5	7.5	mA
		Receiver disabled and driver disabled	0.5	1		
		Receiver enabled and driver enabled	8.5	15		

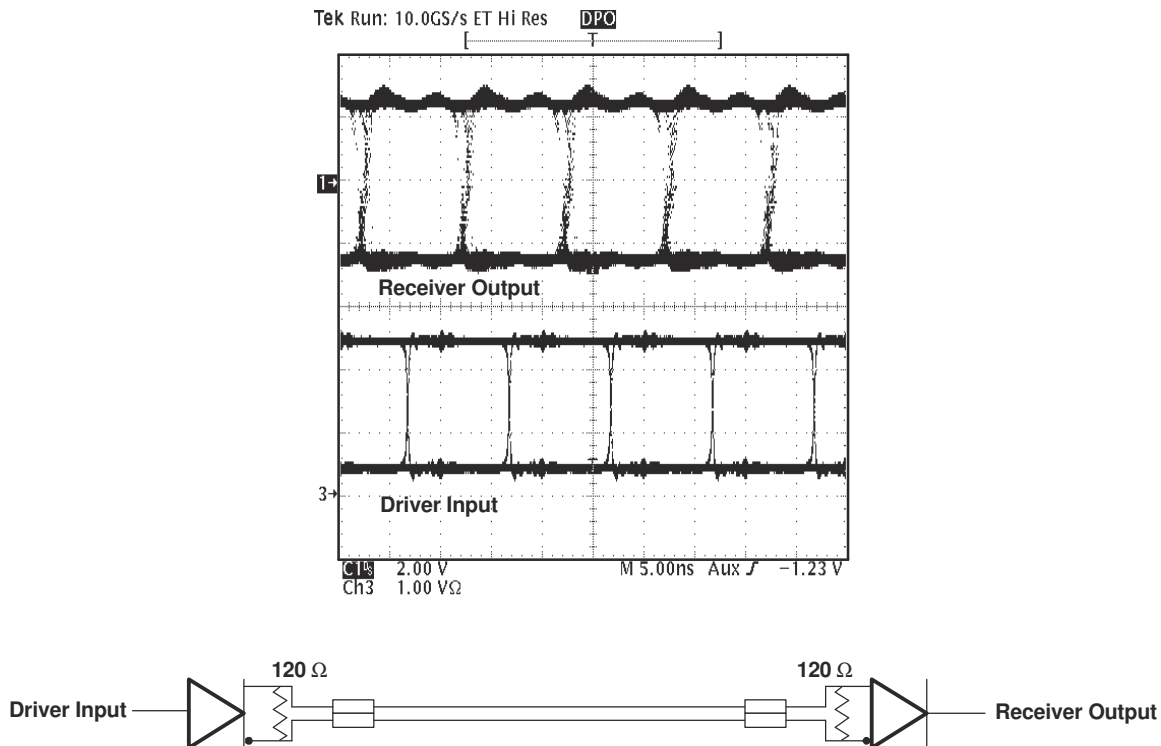
(1) All typical values are at  $V_{CC} = 5 \text{ V}$  and  $T_A = 25^\circ\text{C}$ .

## 5.8 Receiver Switching Characteristics

over recommended operating conditions (unless otherwise noted)

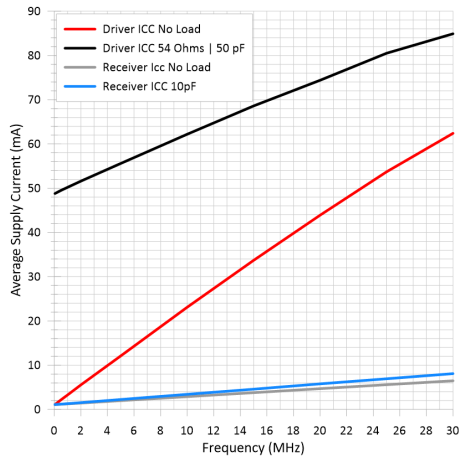
PARAMETER	TEST CONDITIONS	MIN	TYP	MAX	UNIT
$t_{PLH}$ Propagation delay time, low-to-high-level output	$V_{ID} = -1.5\text{ V to }1.5\text{ V}$ , See <a href="#">Figure 6-7</a>	7	13	20	ns
$t_{PHL}$ Propagation delay time, high-to-low-level output		7	13	20	ns
$t_{sk(p)}$ Pulse skew ( $ t_{PHL} - t_{PLH} $ )		0.5	1.5		ns
$t_r$ Output signal rise time		2.1	3.3		ns
$t_f$ Output signal fall time	See <a href="#">Figure 6-7</a>	2.1	3.3		ns
$t_{PZH}$ Output enable time to high level	$C_L = 10\text{ pF}$ , See <a href="#">Figure 6-8</a>		30	45	ns
$t_{PZL}$ Output enable time to low level			30	45	ns
$t_{PHZ}$ Output disable time from high level			20	40	ns
$t_{PLZ}$ Output disable time from low level			20	40	ns

## Typical Characteristics

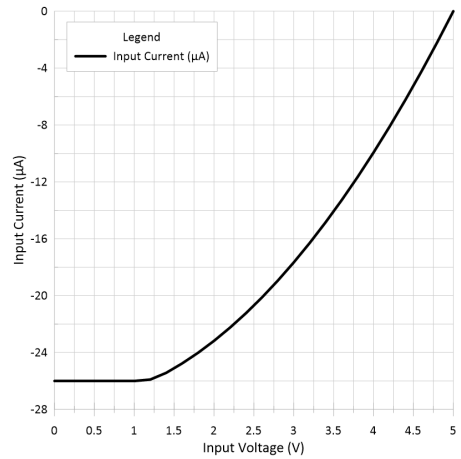


**Figure 5-1. Typical Waveform of Nonreturn-to-Zero (NRZ), Pseudorandom Binary Sequence (PRBS) Data at 100 Mbps Through 15m, of CAT 5 Unshielded Twisted Pair (UTP) Cable**

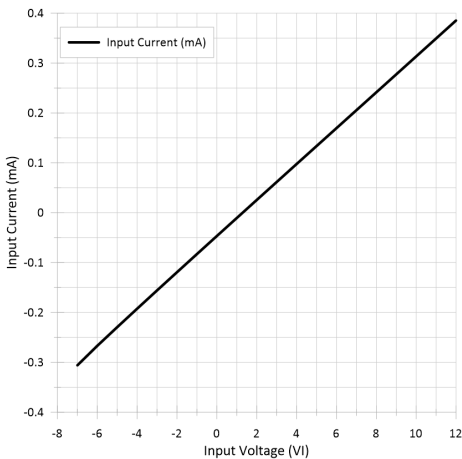
TIA/EIA-485-A defines a maximum signaling rate as that in which the transition time of the voltage transition of a logic-state change remains less than or equal to 30% of the bit length. Transition times of greater length perform quite well even though they do not meet the standard by definition.



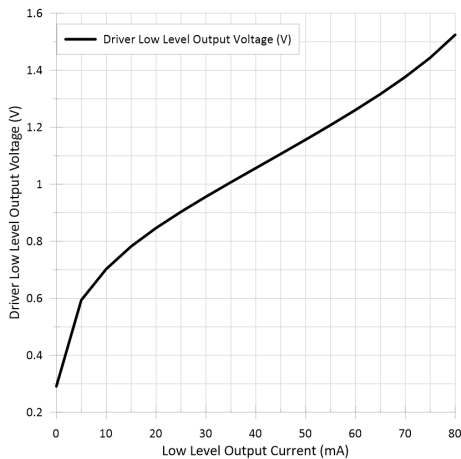
**Figure 5-2. Average Supply Current vs Frequency**



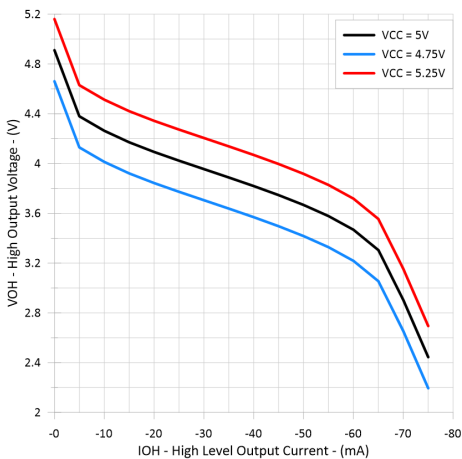
**Figure 5-3. Logic Input Current vs Input Voltage**



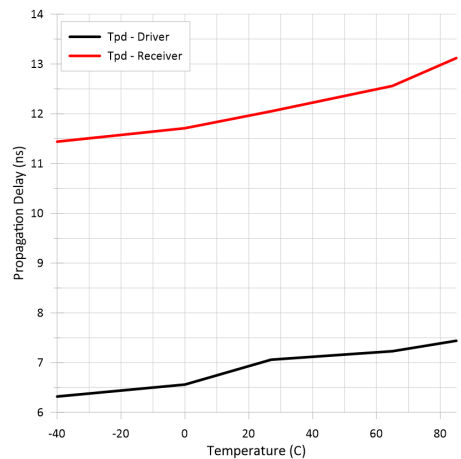
**Figure 5-4. Bus Input Current vs Input Voltage**



**Figure 5-5. Driver Low-Level Output Voltage vs Low-Level Output Current**



**Figure 5-6. Driver High-Level Output Voltage vs High-Level Output Current**



**Figure 5-7. Propagation Delay Time vs Case Temperature**

## Parameter Measurement Information

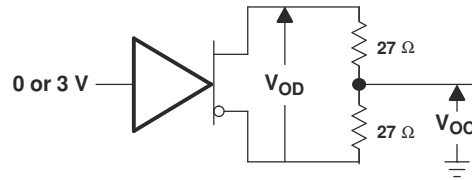


Figure 6-1. Driver  $V_{OD}$  and  $V_{OC}$

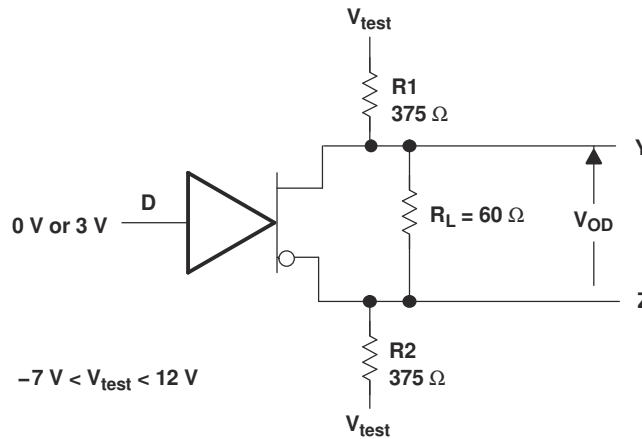
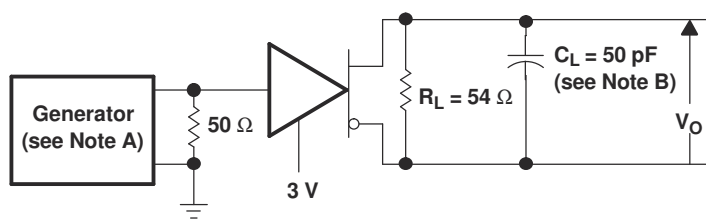
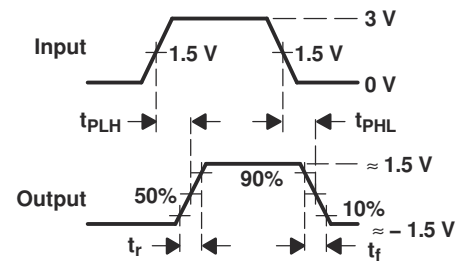


Figure 6-2. Driver  $V_{OD}$



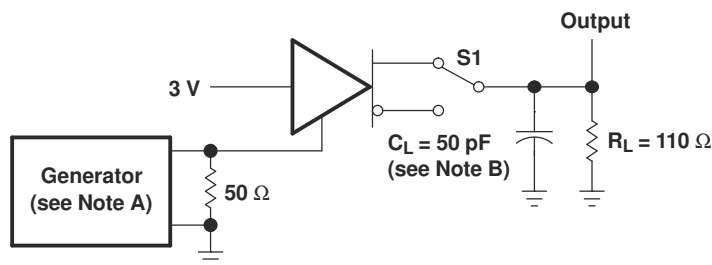
TEST CIRCUIT



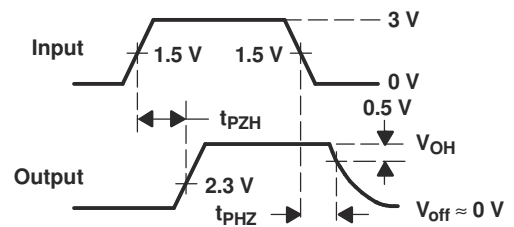
VOLTAGE WAVEFORMS

- The input pulse is supplied by a generator having the following characteristics:  $PRR \leq 1$  MHz, 50% duty cycle,  $t_r \leq 6$  ns,  $t_f \leq 6$  ns,  $Z_O = 50 \Omega$ .
- $C_L$  includes probe and jig capacitance.

Figure 6-3. Driver Test Circuit and Voltage Waveforms



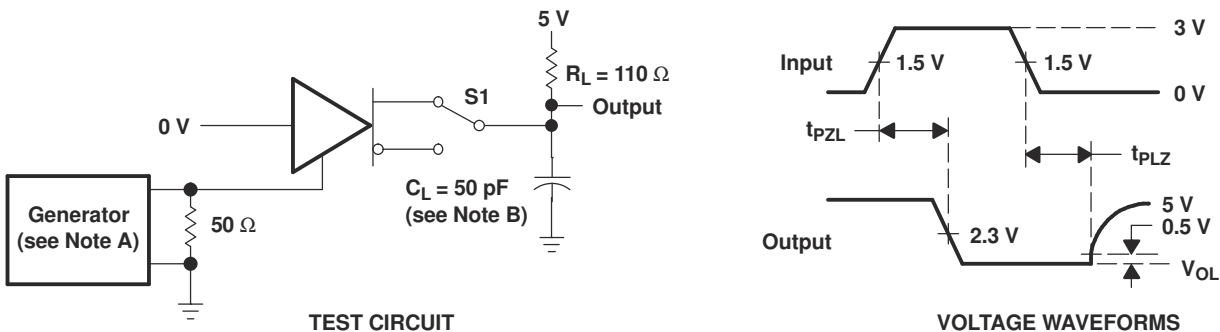
TEST CIRCUIT



VOLTAGE WAVEFORMS

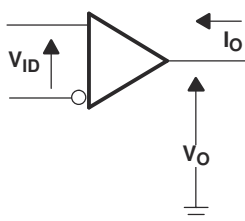
- The input pulse is supplied by a generator having the following characteristics:  $PRR \leq 1$  MHz, 50% duty cycle,  $t_r \leq 6$  ns,  $t_f \leq 6$  ns,  $Z_O = 50 \Omega$ .
- $C_L$  includes probe and jig capacitance.

Figure 6-4. Driver Test Circuit and Voltage Waveforms

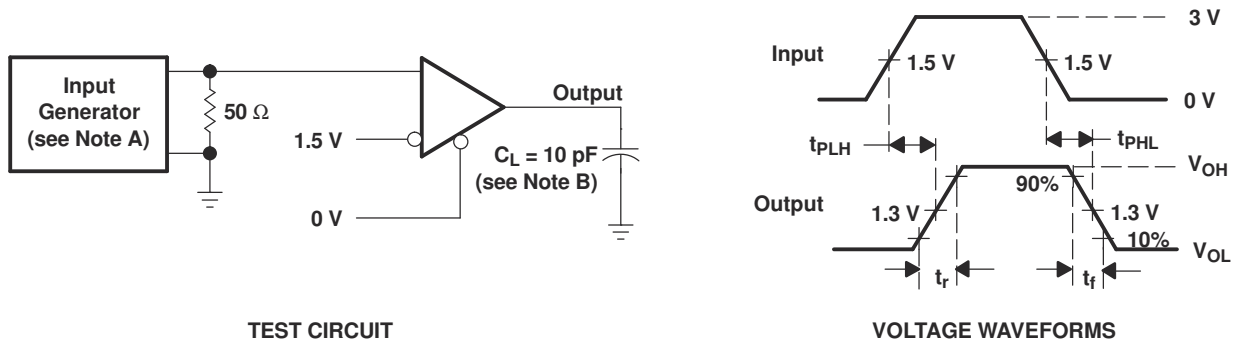


- A. The input pulse is supplied by a generator having the following characteristics: PRR  $\leq$  1 MHz, 50% duty cycle,  $t_r \leq$  6 ns,  $t_f \leq$  6 ns,  $Z_O =$  50  $\Omega$ .
- B.  $C_L$  includes probe and jig capacitance.

**Figure 6-5. Driver Test Circuit and Voltage Waveforms**

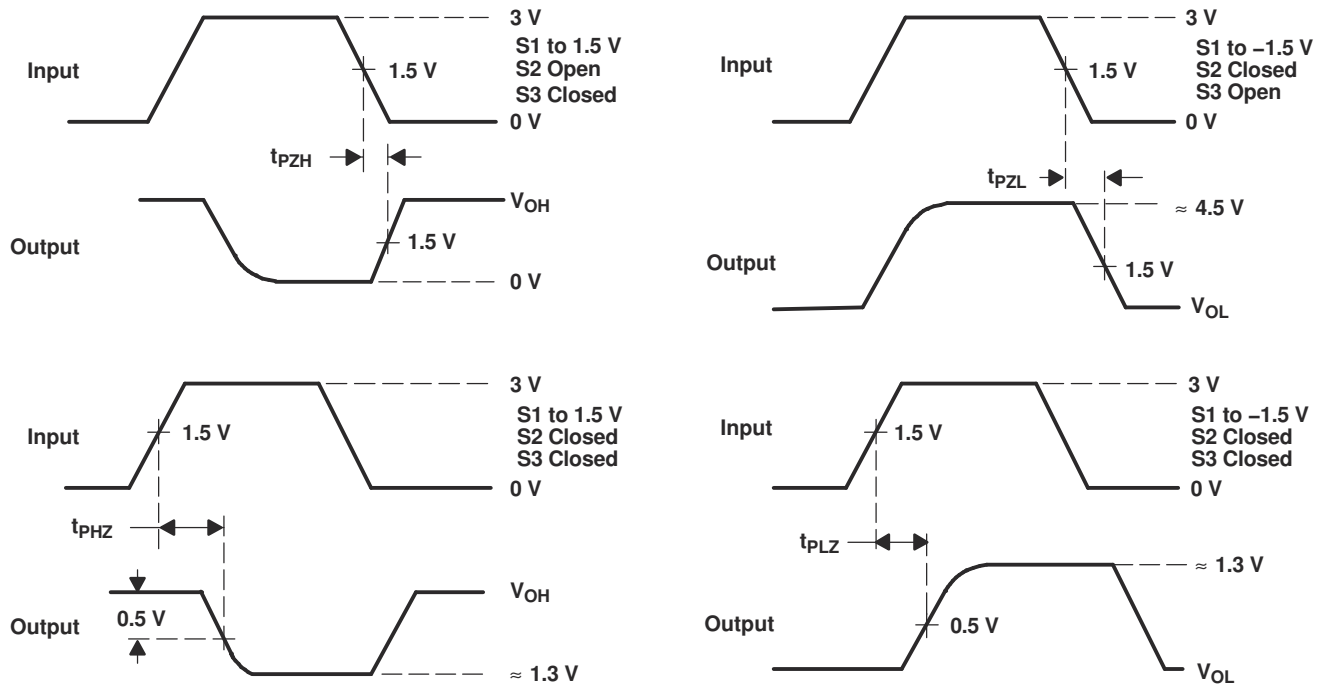
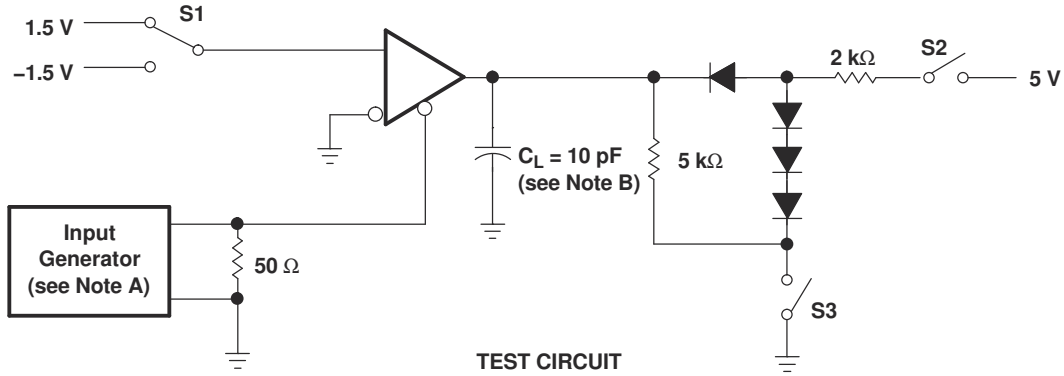


**Figure 6-6. Receiver  $V_{OH}$  and  $V_{OL}$**



- A. The input pulse is supplied by a generator having the following characteristics: PRR  $\leq$  1 MHz, 50% duty cycle,  $t_r \leq$  6 ns,  $t_f \leq$  6 ns,  $Z_O =$  50  $\Omega$ .
- B.  $C_L$  includes probe and jig capacitance.

**Figure 6-7. Receiver Test Circuit and Voltage Waveforms**



VOLTAGE WAVEFORMS

- A. The input pulse is supplied by a generator having the following characteristics: PRR ≤ 1 MHz, 50% duty cycle, t<sub>r</sub> ≤ 6 ns, t<sub>f</sub> ≤ 6 ns, Z<sub>O</sub> = 50 Ω.
- B. C<sub>L</sub> includes probe and jig capacitance.

Figure 6-8. Receiver Output Enable and Disable Times

## 6 Detailed Description

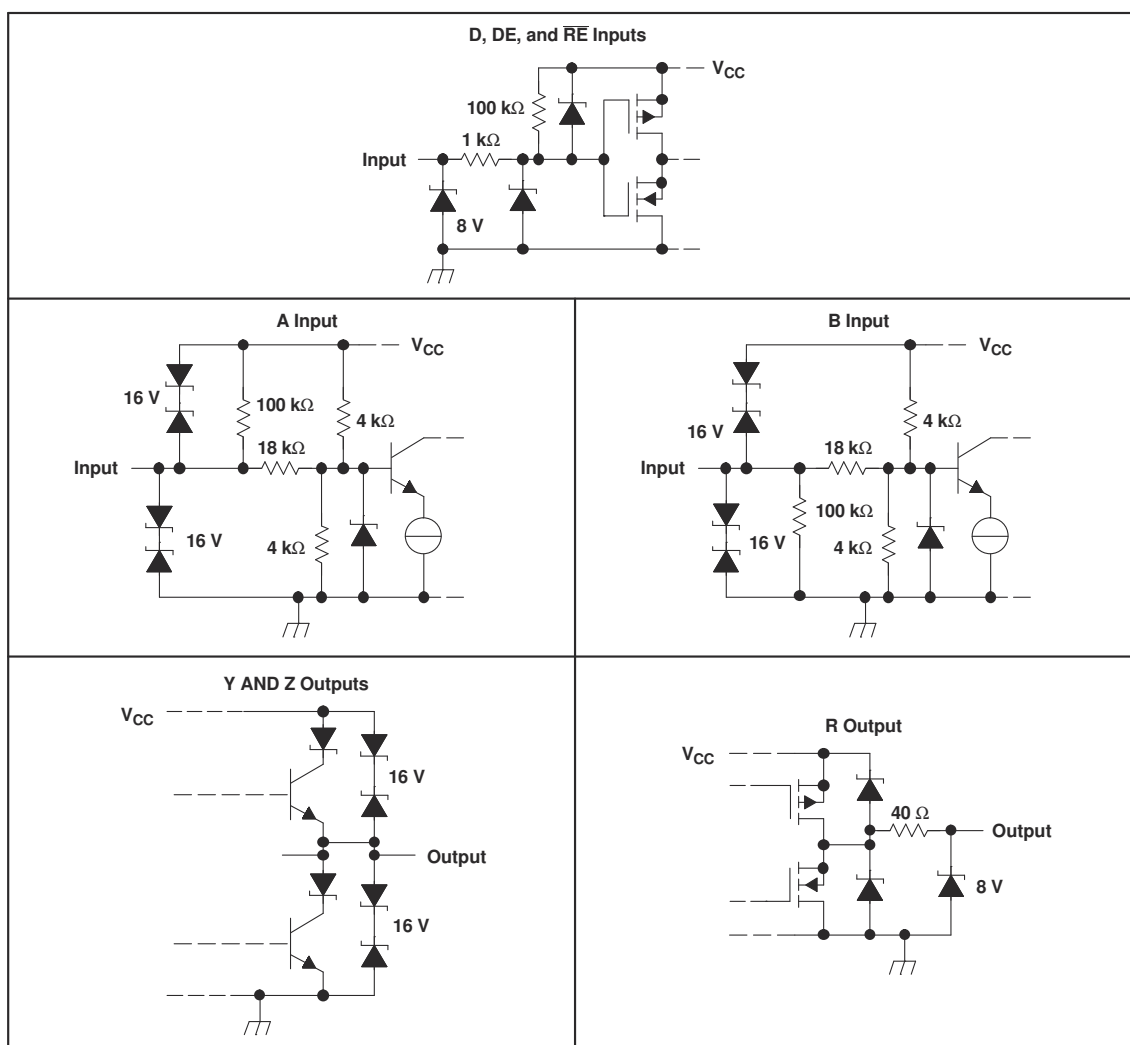
### 6.1 Device Functional Modes

#### 6.1.1 Functional Tables

DRIVER <sup>(1)</sup>				RECEIVER		
INPUT D	ENABLE DE	OUTPUTS		DIFFERENTIAL INPUTS A – B	ENABLE RE	OUTPUT R
		Y	Z			
				$V_{ID} \geq 0.2 \text{ V}$	L	H
H	H	H	L	$-0.2 \text{ V} < V_{ID} < 0.2 \text{ V}$	L	?
L	H	L	H	$V_{ID} \leq -0.2 \text{ V}$	L	L
X	L	Z	Z	X	H	Z
OPEN	H	H	L	Open circuit	L	H

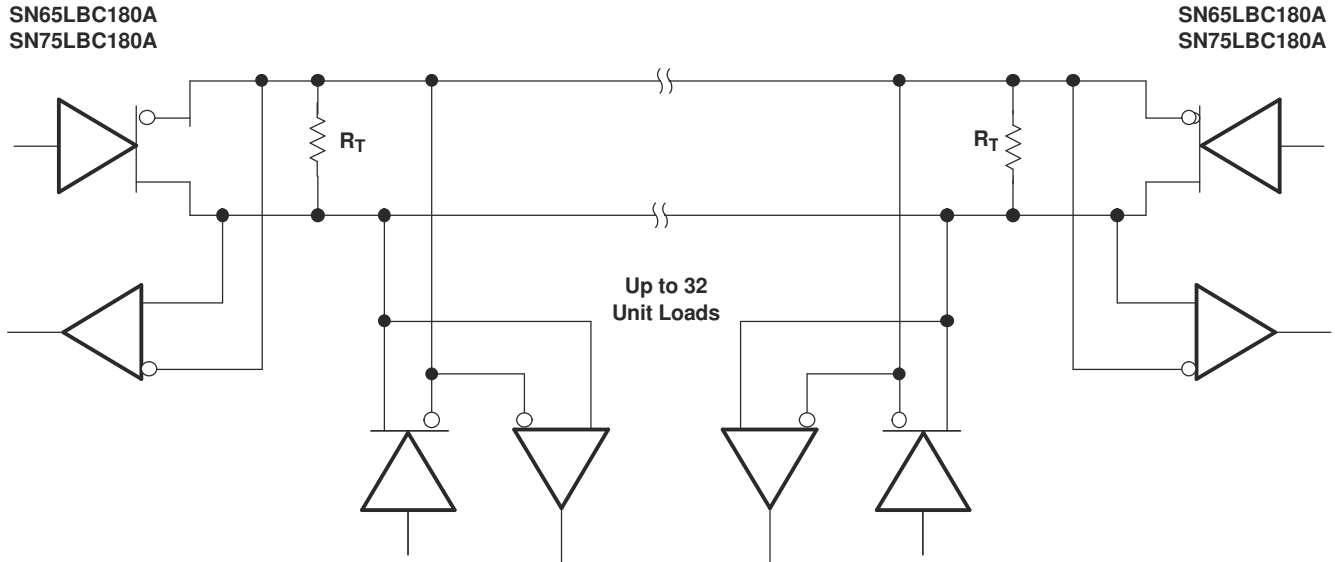
(1) H = high level, L = low level, ? = indeterminate, X = irrelevant, Z = high impedance (off)

#### 6.1.2 Schematics of Inputs and Outputs



## 7 Application Information

### 7.1 Typical Application Circuit



- A. The line should be terminated at both ends in its characteristic impedance ( $R_T = Z_0$ ). Stub lengths off the main line should be kept as short as possible. One SN65LBC180A typically represents less than one unit load.

## 8 Device and Documentation Support

### 8.1 Receiving Notification of Documentation Updates

To receive notification of documentation updates, navigate to the device product folder on [ti.com](http://ti.com). Click on *Subscribe to updates* to register and receive a weekly digest of any product information that has changed. For change details, review the revision history included in any revised document.

### 8.2 Support Resources

TI E2E™ [support forums](#) are an engineer's go-to source for fast, verified answers and design help — straight from the experts. Search existing answers or ask your own question to get the quick design help you need.

Linked content is provided "AS IS" by the respective contributors. They do not constitute TI specifications and do not necessarily reflect TI's views; see TI's [Terms of Use](#).

### 8.3 Trademarks

LinBICMOS™ and TI E2E™ are trademarks of Texas Instruments.  
All trademarks are the property of their respective owners.

### 8.4 Electrostatic Discharge Caution



This integrated circuit can be damaged by ESD. Texas Instruments recommends that all integrated circuits be handled with appropriate precautions. Failure to observe proper handling and installation procedures can cause damage.

ESD damage can range from subtle performance degradation to complete device failure. Precision integrated circuits may be more susceptible to damage because very small parametric changes could cause the device not to meet its published specifications.

### 8.5 Glossary

[TI Glossary](#) This glossary lists and explains terms, acronyms, and definitions.

## 9 Mechanical, Packaging, and Orderable Information

The following pages include mechanical, packaging, and orderable information. This information is the most current data available for the designated devices. This data is subject to change without notice and revision of this document. For browser-based versions of this data sheet, refer to the left-hand navigation.

**PACKAGING INFORMATION**

Orderable Device	Status (1)	Package Type	Package Drawing	Pins	Package Qty	Eco Plan (2)	Lead finish/ Ball material (6)	MSL Peak Temp (3)	Op Temp (°C)	Device Marking (4/5)	Samples
SN65LBC180ADR	ACTIVE	SOIC	D	14	2500	RoHS & Green	NIPDAU	Level-1-260C-UNLIM	-40 to 85	BL180A	<a href="#">Samples</a>
SN65LBC180AN	ACTIVE	PDIP	N	14	25	RoHS & Green	NIPDAU	N / A for Pkg Type	-40 to 85	65LBC180A	<a href="#">Samples</a>
SN75LBC180AN	ACTIVE	PDIP	N	14	25	RoHS & Green	NIPDAU	N / A for Pkg Type	0 to 70	75LBC180A	<a href="#">Samples</a>

(1) The marketing status values are defined as follows:

**ACTIVE:** Product device recommended for new designs.

**LIFEBUY:** TI has announced that the device will be discontinued, and a lifetime-buy period is in effect.

**NRND:** Not recommended for new designs. Device is in production to support existing customers, but TI does not recommend using this part in a new design.

**PREVIEW:** Device has been announced but is not in production. Samples may or may not be available.

**OBSOLETE:** TI has discontinued the production of the device.

(2) **RoHS:** TI defines "RoHS" to mean semiconductor products that are compliant with the current EU RoHS requirements for all 10 RoHS substances, including the requirement that RoHS substance do not exceed 0.1% by weight in homogeneous materials. Where designed to be soldered at high temperatures, "RoHS" products are suitable for use in specified lead-free processes. TI may reference these types of products as "Pb-Free".

**RoHS Exempt:** TI defines "RoHS Exempt" to mean products that contain lead but are compliant with EU RoHS pursuant to a specific EU RoHS exemption.

**Green:** TI defines "Green" to mean the content of Chlorine (Cl) and Bromine (Br) based flame retardants meet JS709B low halogen requirements of <=1000ppm threshold. Antimony trioxide based flame retardants must also meet the <=1000ppm threshold requirement.

(3) MSL, Peak Temp. - The Moisture Sensitivity Level rating according to the JEDEC industry standard classifications, and peak solder temperature.

(4) There may be additional marking, which relates to the logo, the lot trace code information, or the environmental category on the device.

(5) Multiple Device Markings will be inside parentheses. Only one Device Marking contained in parentheses and separated by a "~" will appear on a device. If a line is indented then it is a continuation of the previous line and the two combined represent the entire Device Marking for that device.

(6) Lead finish/Ball material - Orderable Devices may have multiple material finish options. Finish options are separated by a vertical ruled line. Lead finish/Ball material values may wrap to two lines if the finish value exceeds the maximum column width.

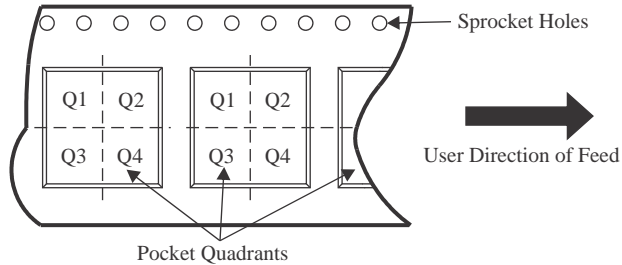
**Important Information and Disclaimer:**The information provided on this page represents TI's knowledge and belief as of the date that it is provided. TI bases its knowledge and belief on information provided by third parties, and makes no representation or warranty as to the accuracy of such information. Efforts are underway to better integrate information from third parties. TI has taken and continues to take reasonable steps to provide representative and accurate information but may not have conducted destructive testing or chemical analysis on incoming materials and chemicals. TI and TI suppliers consider certain information to be proprietary, and thus CAS numbers and other limited information may not be available for release.

In no event shall TI's liability arising out of such information exceed the total purchase price of the TI part(s) at issue in this document sold by TI to Customer on an annual basis.

## TAPE AND REEL INFORMATION



### QUADRANT ASSIGNMENTS FOR PIN 1 ORIENTATION IN TAPE



\*All dimensions are nominal

Device	Package Type	Package Drawing	Pins	SPQ	Reel Diameter (mm)	Reel Width W1 (mm)	A0 (mm)	B0 (mm)	K0 (mm)	P1 (mm)	W (mm)	Pin1 Quadrant
SN65LBC180ADR	SOIC	D	14	2500	330.0	16.4	6.5	9.0	2.1	8.0	16.0	Q1

**TAPE AND REEL BOX DIMENSIONS**


\*All dimensions are nominal

Device	Package Type	Package Drawing	Pins	SPQ	Length (mm)	Width (mm)	Height (mm)
SN65LBC180ADR	SOIC	D	14	2500	356.0	356.0	35.0

**TUBE**


\*All dimensions are nominal

Device	Package Name	Package Type	Pins	SPQ	L (mm)	W (mm)	T (μm)	B (mm)
SN65LBC180AN	N	PDIP	14	25	506	13.97	11230	4.32
SN75LBC180AN	N	PDIP	14	25	506	13.97	11230	4.32

D (R-PDSO-G14)

PLASTIC SMALL OUTLINE



- NOTES:
- A. All linear dimensions are in inches (millimeters).
  - B. This drawing is subject to change without notice.
  -  Body length does not include mold flash, protrusions, or gate burrs. Mold flash, protrusions, or gate burrs shall not exceed 0.006 (0,15) each side.
  -  Body width does not include interlead flash. Interlead flash shall not exceed 0.017 (0,43) each side.
  - E. Reference JEDEC MS-012 variation AB.

D (R-PDSO-G14)

PLASTIC SMALL OUTLINE



- NOTES:
- A. All linear dimensions are in millimeters.
  - B. This drawing is subject to change without notice.
  - C. Publication IPC-7351 is recommended for alternate designs.
  - D. Laser cutting apertures with trapezoidal walls and also rounding corners will offer better paste release. Customers should contact their board assembly site for stencil design recommendations. Refer to IPC-7525 for other stencil recommendations.
  - E. Customers should contact their board fabrication site for solder mask tolerances between and around signal pads.

N (R-PDIP-T\*\*)

PLASTIC DUAL-IN-LINE PACKAGE

16 PINS SHOWN



- NOTES:
- A. All linear dimensions are in inches (millimeters).
  - B. This drawing is subject to change without notice.
  - C. Falls within JEDEC MS-001, except 18 and 20 pin minimum body length (Dim A).
  - D. The 20 pin end lead shoulder width is a vendor option, either half or full width.

4040049/E 12/2002

## IMPORTANT NOTICE AND DISCLAIMER

TI PROVIDES TECHNICAL AND RELIABILITY DATA (INCLUDING DATA SHEETS), DESIGN RESOURCES (INCLUDING REFERENCE DESIGNS), APPLICATION OR OTHER DESIGN ADVICE, WEB TOOLS, SAFETY INFORMATION, AND OTHER RESOURCES "AS IS" AND WITH ALL FAULTS, AND DISCLAIMS ALL WARRANTIES, EXPRESS AND IMPLIED, INCLUDING WITHOUT LIMITATION ANY IMPLIED WARRANTIES OF MERCHANTABILITY, FITNESS FOR A PARTICULAR PURPOSE OR NON-INFRINGEMENT OF THIRD PARTY INTELLECTUAL PROPERTY RIGHTS.

These resources are intended for skilled developers designing with TI products. You are solely responsible for (1) selecting the appropriate TI products for your application, (2) designing, validating and testing your application, and (3) ensuring your application meets applicable standards, and any other safety, security, regulatory or other requirements.

These resources are subject to change without notice. TI grants you permission to use these resources only for development of an application that uses the TI products described in the resource. Other reproduction and display of these resources is prohibited. No license is granted to any other TI intellectual property right or to any third party intellectual property right. TI disclaims responsibility for, and you will fully indemnify TI and its representatives against, any claims, damages, costs, losses, and liabilities arising out of your use of these resources.

TI's products are provided subject to [TI's Terms of Sale](#) or other applicable terms available either on [ti.com](https://www.ti.com) or provided in conjunction with such TI products. TI's provision of these resources does not expand or otherwise alter TI's applicable warranties or warranty disclaimers for TI products.

TI objects to and rejects any additional or different terms you may have proposed.

Mailing Address: Texas Instruments, Post Office Box 655303, Dallas, Texas 75265  
Copyright © 2024, Texas Instruments Incorporated

## Looking for pricing, stock, or lifecycle information?

Click below to explore more details on WIN SOURCE:

 [View SN75LBC180ADR on WIN SOURCE](#)

 [Texas Instruments](#) Information

## Optimize Your Supply Chain with WIN SOURCE Solutions

-  Global Sourcing Solution
-  Obsolete Management
-  Cost Control Management
-  Shortage Management
-  Alternative Solution
-  Excess Inventory Management