



**THE DATASHEET OF
SN75LBC176ADR**



SNx5LBC176A, Differential Bus Transceivers

1 Features

- Designed for signaling rates¹ up to 30 Mbps
- Bus-Pin ESD protection exceeds 12 kV HBM
- Compatible with ANSI standard TIA/EIA-485-A and ISO 8482:1987(E)
- Low Skew
- Designed for multipoint transmission on long bus lines in noisy environments
- Very low disabled supply-current requirements: 700 mA maximum
- Common mode voltage range of -7 V to 12 V
- Thermal-shutdown protection
- Driver positive and negative current limiting
- Open-circuit failsafe receiver design
- Receiver input sensitivity: $\pm 200\text{ mV}$ Maximum
- Receiver input hysteresis: 50 mV typical
- Glitch-free power-up and power-down protection
- Available in Q-temp automotive
 - High reliability automotive applications
 - Configuration control / print support
 - Qualification to automotive standards

2 Description

The SN65LBC176A, SN65LBC176AQ, and SN75LBC176A differential bus transceivers are monolithic, integrated circuits designed for bidirectional data communication on multipoint bus-transmission lines. They are designed for balanced

transmission lines and are compatible with ANSI standard TIA/EIA-485-A and ISO 8482. The A version offers improved switching performance over its predecessors without sacrificing significantly more power.

The SN65LBC176A, SN65LBC176AQ, and SN75LBC176A combine a 3-state, differential line driver and a differential input line receiver, both of which operate from a single 5-V power supply. The driver and receiver have active-high and active-low enables, respectively, which can externally connect together to function as a direction control. The driver differential outputs and the receiver differential inputs connect internally to form a differential input /output (I/O) bus port that is designed to offer minimum loading to the bus whenever the driver is disabled or $V_{CC} = 0$. This port features wide positive and negative common-mode voltage ranges, making the device suitable for party-line applications. Very low device supply current can be achieved by disabling the driver and the receiver.

Package Information

PART NUMBER	PACKAGE ⁽¹⁾	BODY SIZE (NOM)
SN65LBC176A	D (SOIC)	4.9 mm x 3.91 mm
SN75LBC176A	P (PDIP)	9.81 mm x 6.35 mm

(1) For all available packages, see the orderable addendum at the end of the data sheet.

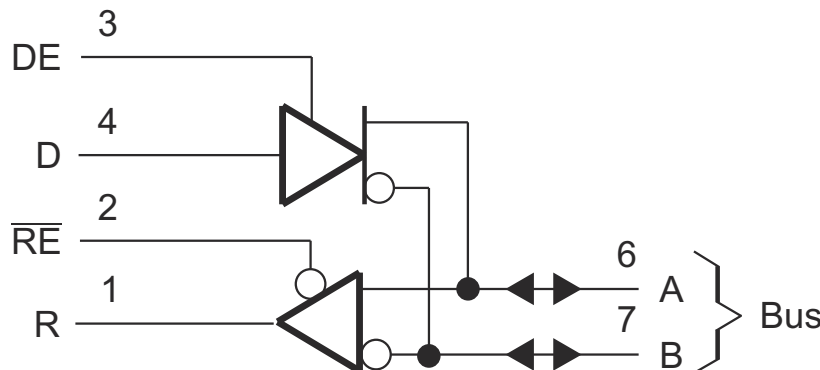

¹ Signaling rate by TIA/EIA-485-A definition restrict transition times to 30% of the bit duration, and much higher signaling rates may be achieved using a different criteria (see the Typical Characteristics section).



Table of Contents

1 Features	1	5.8 Receiver Switching Characteristics.....	7
2 Description	1	Typical Characteristics.....	8
3 Revision History	2	Parameter Measurement Information	12
4 Pin Configuration and Functions	3	6 Detailed Description	15
5 Specifications	4	6.1 Device Functional Modes.....	15
5.1 Absolute Maximum Ratings.....	4	7 Device and Documentation Support	16
5.2 Dissipation Ratings.....	4	7.1 Receiving Notification of Documentation Updates...	16
5.3 Recommended Operating Conditions.....	4	7.2 Support Resources.....	16
5.4 Thermal Information.....	5	7.3 Trademarks.....	16
5.5 Driver Electrical Characteristics.....	5	7.4 Electrostatic Discharge Caution.....	16
5.6 Driver Switching Characteristics.....	6	7.5 Glossary.....	16
5.7 Receiver Electrical Characteristics.....	6	8 Mechanical, Packaging, and Orderable Information..	16

3 Revision History

NOTE: Page numbers for previous revisions may differ from page numbers in the current version.

Changes from Revision F (January 2023) to Revision G (February 2023)	Page
• Changed the <i>Thermal Information</i> table.....	5

Changes from Revision E (January 2023) to Revision F (January 2023)	Page
• Changed the SN65LBC176AQ values in the <i>Thermal Information</i> table.....	5

Changes from Revision D (August 200/8) to Revision E (January 2023)	Page
• Changed the document to the latest TI format.....	1
• Added the <i>Thermal Information</i> table.....	5

4 Pin Configuration and Functions

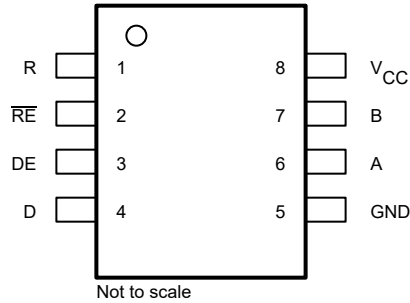

**Figure 4-1. SN65LBC176AQD (Marked as B176AQ)
SN65LBC176AD (Marked as BL176A)
SN65LBC176AP (Marked as 65LBC176A)
SN75LBC176AD (Marked as LB176A)
SN75LBC176AP (Marked as 75LBC176A)
(Top View)**

Table 4-1. Pin Functions

NO	NAME	TYPE	DESCRIPTION
1	R	O	Receive data output
2	\overline{RE}	I	Receiver enable, active low
3	DE	I	Driver enable, active high
4	D	I	Driver data input
5	GND	GND	Device ground
6	A	I/O	Bus I/O port, A (complementary to B)
7	B	I/O	Bus I/O port, B(complementary to A)
8	V _{CC}	P	5 V Supply Pin

5 Specifications

5.1 Absolute Maximum Ratings

over operating free-air temperature range (unless otherwise noted)⁽¹⁾

		VALUE	UNIT
Supply voltage, V_{CC} ⁽²⁾		-0.3 to 6	V
Voltage range at any bus terminal (A or B)		-10 to 15	V
Input voltage, V_I (D, DE, R, or \overline{RE})		-0.3 to $V_{CC} + 0.5$	V
Electrostatic discharge:	Bus terminals and GND, Class 3, A: ⁽³⁾	12	kV
	Bus terminals and GND, Class 3, B: ⁽³⁾	400	V
	All terminals, Class 3, A	3	kV
	All terminals, Class 3, B	400	V
Continuous total power dissipation ⁽⁴⁾		See Dissipation Rating Table	
Storage temperature range, T_{stg}		-65 to 150	°C

- (1) Stresses beyond those listed under *absolute maximum ratings* may cause permanent damage to the device. These are stress ratings only, and functional operation of the device at these or any other conditions beyond those indicated under *recommended operating conditions* is not implied. Exposure to absolute-maximum-rated conditions for extended periods may affect device reliability.
- (2) All voltage values, except differential I/O bus voltage, are with respect to network ground terminal.
- (3) The maximum operating junction temperature is internally limited. Use the dissipation rating table to operate below this temperature.
- (4) Tested in accordance with MIL-STD-883C, Method 3015.7

5.2 Dissipation Ratings

PACKAGE	$T_A \leq 25^\circ\text{C}$ POWER RATING	DERATING FACTOR ⁽¹⁾ ABOVE $T_A = 25^\circ\text{C}$	$T_A = 70^\circ\text{C}$ POWER RATING	$T_A = 85^\circ\text{C}$ POWER RATING	$T_A = 125^\circ\text{C}$ POWER RATING
D	725 mW	5.5 mW/°C	464 mW	377 mW	145 mW
P	1000 mW	8.0 mW/°C	640 mW	520 mW	—

- (1) This is the inverse of the junction-to-ambient thermal resistance when board-mounted and with no air flow.

5.3 Recommended Operating Conditions

		MIN	NOM	MAX	UNIT
V_{CC}	Supply voltage	4.75	5	5.25	V
V_I or V_{IC}	Voltage at any bus terminal (separately or common mode)	-7		12	V
V_{IH}	High-level input voltage	D, DE, and \overline{RE}		V_{CC}	V
V_{IL}	Low-level input voltage	D, DE, and \overline{RE}		0.8	V
V_{ID}	Differential input voltage ⁽²⁾	-12 ⁽¹⁾		12	V
I_{OH}	High-level output current	Driver	-60		mA
		Receiver	-8		
I_{OL}	Low-level output current	Driver	60		mA
		Receiver	8		
T_A	Operating free-air temperature	SN65LBC176AQ	-40	125	°C
		SN65LBC176A	-40	85	
		SN75LBC176A	0	70	

- (1) The algebraic convention, in which the least positive (most negative) limit is designated as minimum, is used in this data sheet.
- (2) Differential input/output bus voltage is measured at the noninverting terminal A with respect to the inverting terminal B.

5.4 Thermal Information

THERMAL METRIC ⁽¹⁾		All Devices in 'P' Package	SN65LBC176ADR SN65LBC176AQDR	OPNs Not Listed in Previous Column	UNIT
		P (PDIP)	D (SOIC)	D (SOIC)	
		8-Pins	8-Pins	8-Pins	
$R_{\theta JA}$	Junction-to-ambient thermal resistance	65.7	116.7	110	°C/W
$R_{\theta JC}$	Junction-to-case thermal resistance	54.7	56.3	44.1	°C/W
$R_{\theta JB}$	Junction-to-board thermal resistance	42.1	63.4	53.5	°C/W
Ψ_{JT}	Junction-to-top characterization parameter	23	8.8	4.8	°C/W
Ψ_{JB}	Junction-to-board characterization parameter	41.7	62.9	52.7	°C/W

(1) For more information about traditional and new thermal metrics, see the [Semiconductor and IC package thermal metrics](#) application report.

5.5 Driver Electrical Characteristics

over recommended operating conditions (unless otherwise noted)

PARAMETER	TEST CONDITIONS	MIN	TYP ⁽¹⁾	MAX	UNIT	
V_{IK}	Input clamp voltage $I_I = -18 \text{ mA}$	-1.5	-0.8		V	
$ V_{OD} $	$I_O = 0$	SN65LBC176AQ	1.5	4	6	V
		SN65LBC176A, SN75LBC176A		4		
	$R_L = 54 \Omega$, See Figure 6-1	SN65LBC176AQ	0.9	1.5	6	V
		SN65LBC176A	1	1.5	3	
		SN75LBC176A	1.1	1.5	3	
	$V_{test} = -7 \text{ to } 12 \text{ V}$, See Figure 6-2	SN65LBC176AQ	0.9	1.5	6	V
SN65LBC176A		1	1.5	3		
SN75LBC176A		1.1	1.5	3		
$\Delta V_{OD} $	Change in magnitude of differential output voltage See Figure 6-1 and Figure 6-2	-0.2		0.2	V	
$V_{OC(SS)}$	Steady-state common-mode output voltage See Figure 6-1					
$\Delta V_{OC(SS)}$	Change in steady-state common-mode output voltage	SN65LBC176AQ	1.8	2.4	3	V
		SN65LBC176A, SN75LBC176A	1.8	2.4	2.8	
$\Delta V_{OC(SS)}$	Change in steady-state common-mode output voltage	SN65LBC176AQ	-0.2		0.2	V
		SN65LBC176A, SN75LBC176A	-0.1		0.1	
I_{OZ}	High-impedance output current See receiver input currents					
I_{IH}	High-level enable input current $V_I = 2 \text{ V}$	-100			μA	
I_{IL}	Low-level enable input current $V_I = 0.8 \text{ V}$	-100			μA	
I_{OS}	Short-circuit output current $-7 \text{ V} \leq V_O \leq 12 \text{ V}$	-250		250	mA	
I_{CC}	Supply current $V_I = 0 \text{ or } V_{CC}$, No load	Receiver disabled and driver enabled		5	9	mA
		Receiver disabled and driver disabled		0.4	0.7	
		Receiver enabled and driver enabled		8.5	15	

(1) All typical values are at $V_{CC} = 5 \text{ V}$, $T_A = 25^\circ\text{C}$.

5.6 Driver Switching Characteristics

over recommended operating conditions (unless otherwise noted)

PARAMETER	TEST CONDITIONS	SN65LBC176AQ			SN65LBC176A SN75LBC176A			UNIT
		MIN	TYP ⁽¹⁾	MAX	MIN	TYP ⁽¹⁾	MAX	
t _{PLH}	Propagation delay time, low-to-high-level output	2		12	2	6	12	ns
t _{PHL}	Propagation delay time, high-to-low-level output	2		12	2	6	12	ns
t _{sk(p)}	Pulse skew (t _{PLH} - t _{PHL})			2		0.3	1	ns
t _r	Differential output signal rise time	1.2		11	4	7.5	11	ns
t _f	Differential output signal fall time	1.2		11	4	7.5	11	ns
t _{PZH}	Propagation delay time, high-impedance-to-high-level output			22		12	22	ns
t _{PZL}	Propagation delay time, high-impedance-to-low-level output			25		12	22	ns
t _{PHZ}	Propagation delay time, high-level-to-high-impedance output			22		12	22	ns
t _{PLZ}	Propagation delay time, low-level-to-high-impedance output			22		12	22	ns

(1) All typical values are at V_{CC} = 5 V, T_A = 25°C.

5.7 Receiver Electrical Characteristics

over operating free-air temperature range (unless otherwise noted)

PARAMETER	TEST CONDITIONS	MIN	TYP ⁽¹⁾	MAX	UNIT	
V _{IT+}	Positive-going input threshold voltage			0.2	V	
V _{IT-}	Negative-going input threshold voltage	-0.2			V	
V _{hys}	Hysteresis voltage (V _{IT+} - V _{IT-})		50		mV	
V _{IK}	Enable-input clamp voltage	-1.5	-0.8		V	
V _{OH}	High-level output voltage	V _{ID} = 200 mV, I _{OH} = -8 mA, See Figure 6-6	4	4.9	V	
V _{OL}	Low-level output voltage	V _{ID} = -200 mV, I _{OH} = 8 mA, See Figure 6-6		0.1	0.8	V
I _{OZ}	High-impedance-state output current	V _O = 0 to V _{CC}	SN65LBC176AQ	-10	10	μA
			SN65LBC176A, SN75LBC176A	-1	1	
I _I	Bus input current	V _{IH} = 12 V, V _{CC} = 5 V V _{IH} = 12 V, V _{CC} = 0 V _{IH} = -7 V, V _{CC} = 5 V V _{IH} = -7 V, V _{CC} = 0	Other input at 0 V	0.4	1	mA
				0.5	1	
				-0.8	-0.4	
				-0.8	-0.3	
I _{IH}	High-level enable-input current	V _{IH} = 2 V		-100		μA
I _{IL}	Low-level enable-input current	V _{IL} = 0.8 V		-100		μA
I _{CC}	Supply current	V _I = 0 or V _{CC} , No load	Receiver enabled and driver disabled	4	7	mA
			Receiver disabled and driver disabled	0.4	0.7	
			Receiver enabled and driver enabled	8.5	15	

(1) All typical values are at V_{CC} = 5 V, T_A = 25°C.

5.8 Receiver Switching Characteristics

over recommended operating conditions (unless otherwise noted)

PARAMETER	TEST CONDITIONS	SN65LBC176AQ			SN65LBC176A SN75LBC176A			UNIT
		MIN	TYP ⁽¹⁾	MAX	MIN	TYP ⁽¹⁾	MAX	
t_{PLH} Propagation delay time output↑	$V_{ID} = -1.5\text{ V to }1.5\text{ V}$, See Figure 6-7	7		30	7	13	20	ns
t_{PHL} Propagation delay time output↓		7		30	7	13	20	ns
$t_{sk(p)}$ Pulse skew ($t_{PLH} - t_{PHL}$)				6		0.5	1.5	ns
t_r Rise time, output	See Figure 6-7			5		2.1	3.3	ns
t_f Fall time, output				5		2.1	3.3	ns
t_{PZH} Output enable time to high level	$C_L = 10\text{ pF}$, See Figure 6-8			50		30	45	ns
t_{PZL} Output enable time to low level				50		30	45	ns
t_{PHZ} Output disable time to high level				60		20	40	ns
t_{PLZ} Output disable time to low level				60		20	40	ns

(1) All typical values are at $V_{CC} = 5\text{ V}$, $T_A = 25^\circ\text{C}$.

Typical Characteristics

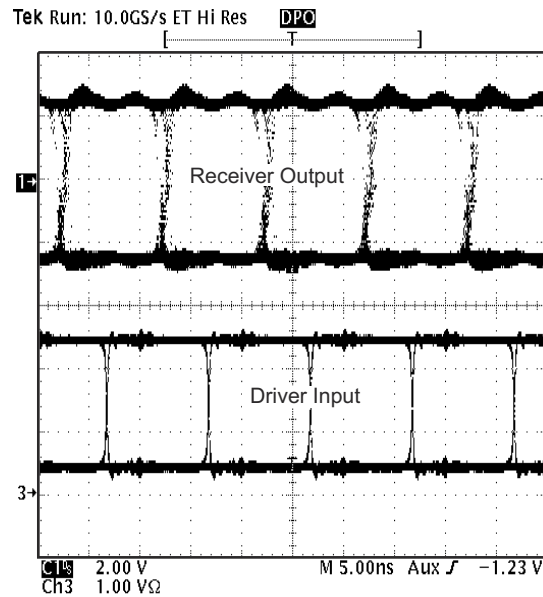

Figure 5-1. Typical Waveform of Non-Return-To-Zero (NRZ), Pseudorandom Binary Sequence (PRBS) Data at 100 Mbps Through 15m, of CAT 5 Unshielded Twisted Pair (UTP) Cable

TIA/EIA-485-A defines a maximum signaling rate as that in which the transition time of the voltage transition of a logic-state change remains less than or equal to 30% of the bit length. Transition times of greater length perform quite well even though they do not meet the standard definition.

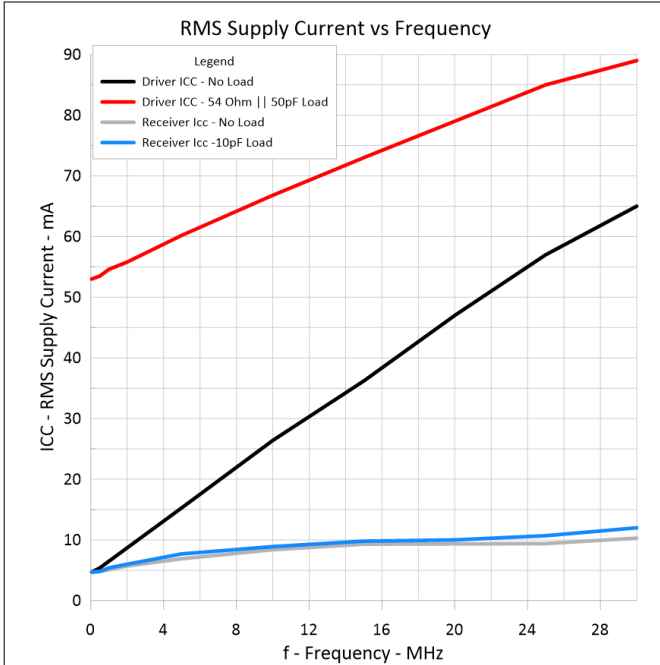

Figure 5-2. RMS Supply Current vs Frequency

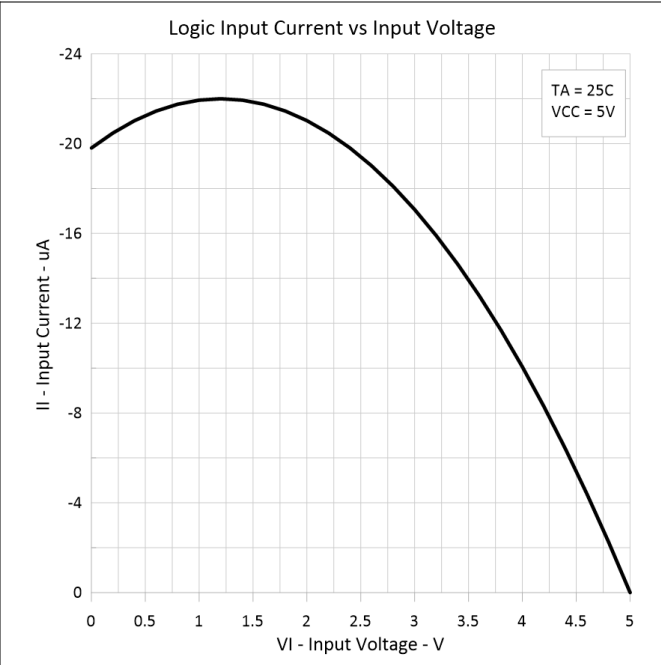

Figure 5-3. Logic Input Current vs Input Voltage

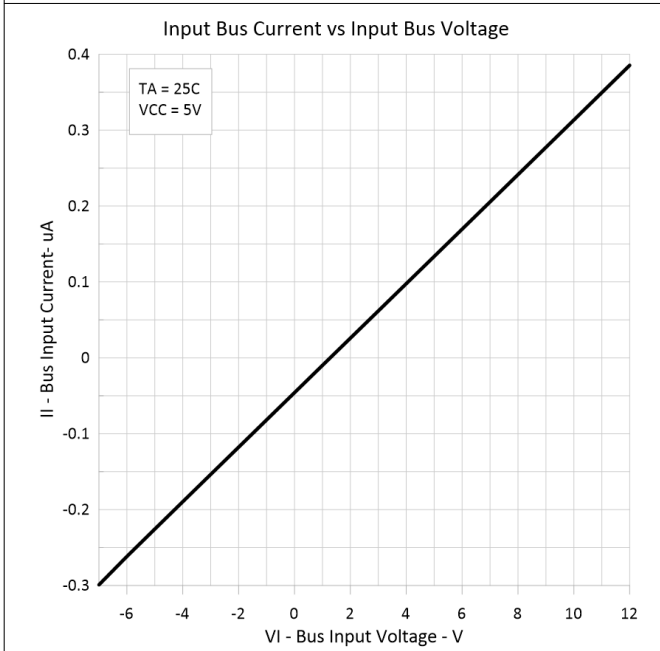

Figure 5-4. Input Current vs Input Voltage

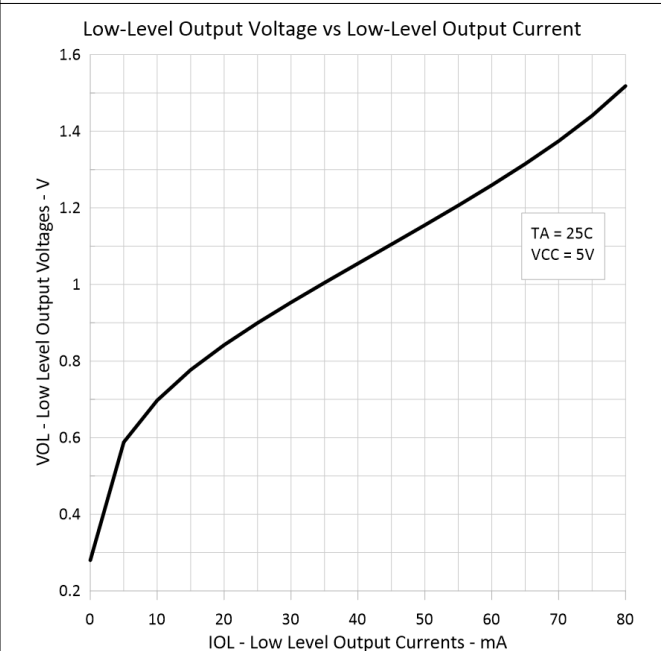

Figure 5-5. Low-Level Output Voltage vs Low-Level Output Current

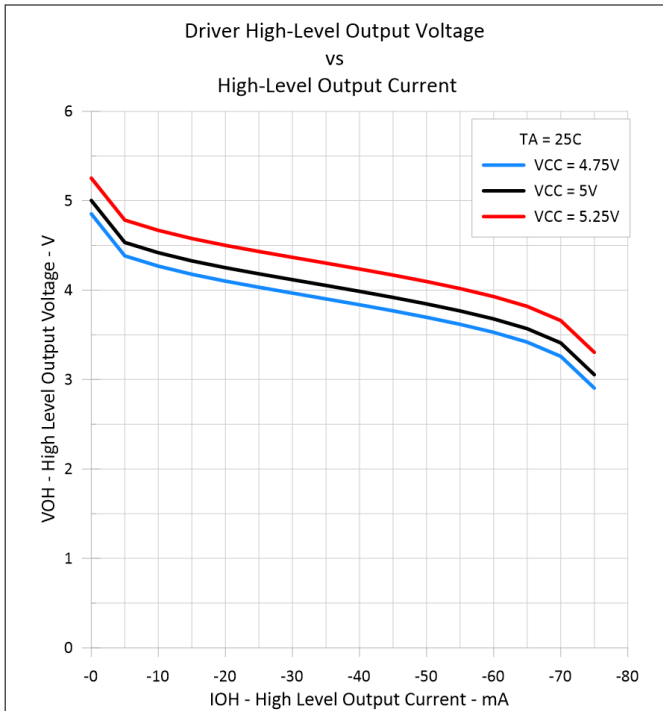

Figure 5-6. Driver High-Level Output Voltage vs High-Level Output Current

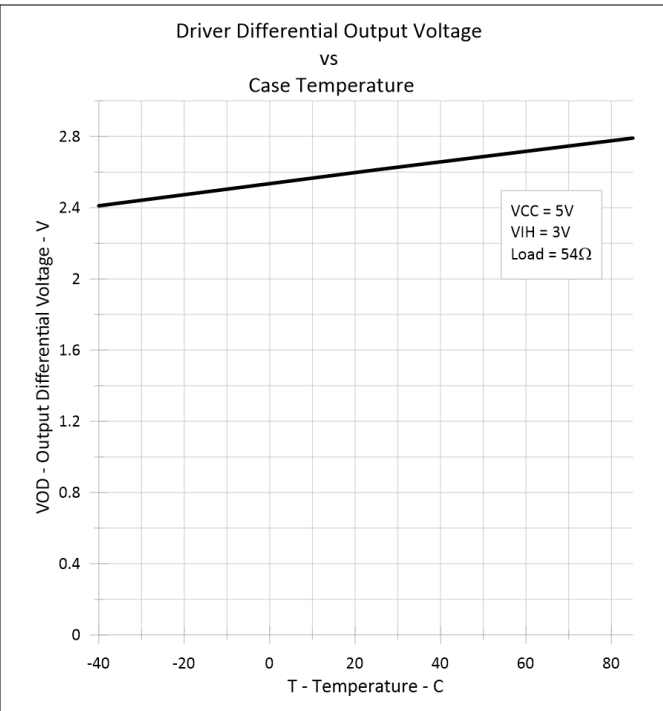

Figure 5-7. Driver Differential Output Voltage vs Case Temperature

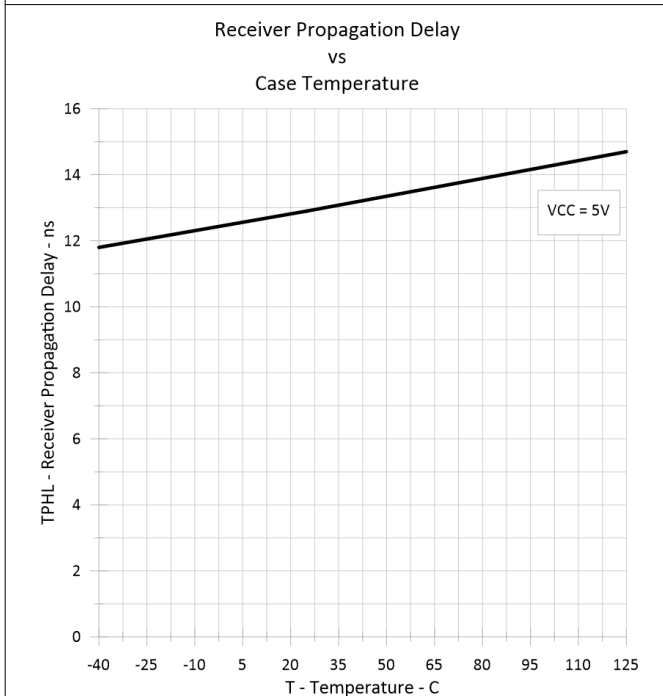

Figure 5-8. Receiver Propagation Time vs Case Temperature

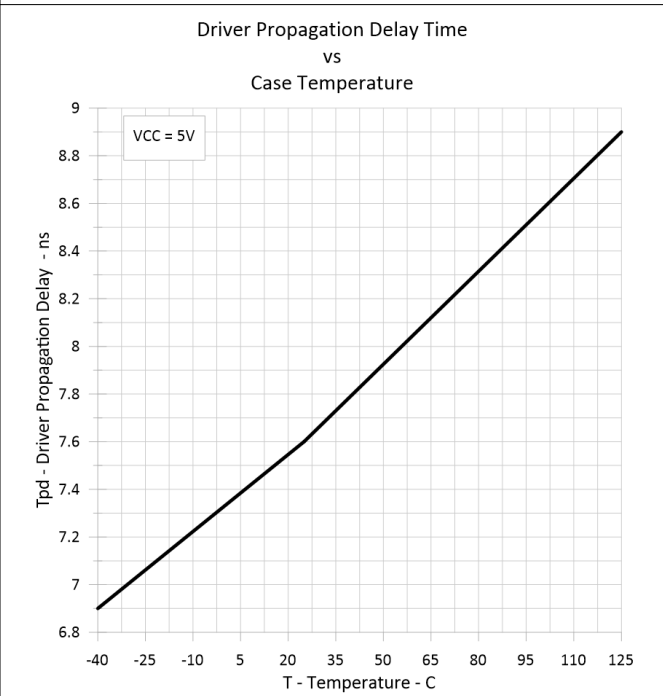
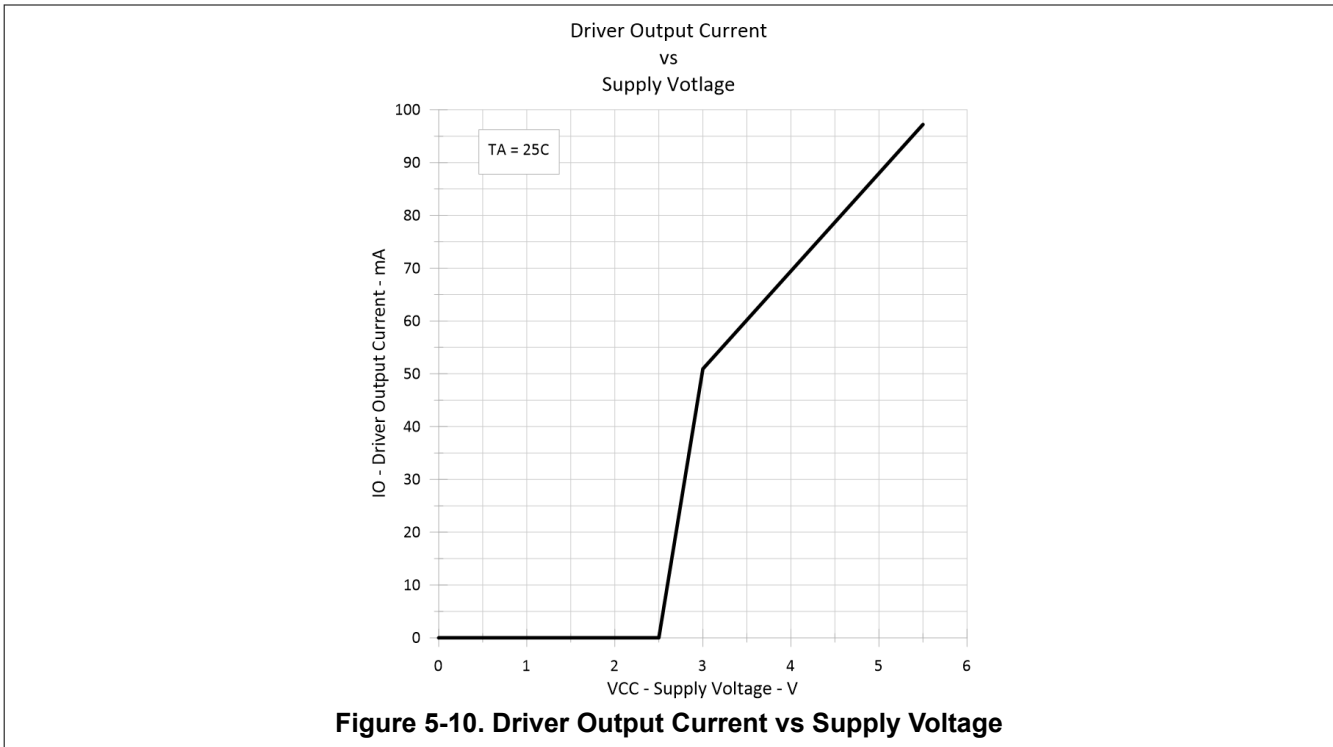

Figure 5-9. Driver Propagation Delay Time vs Case Temperature



Parameter Measurement Information

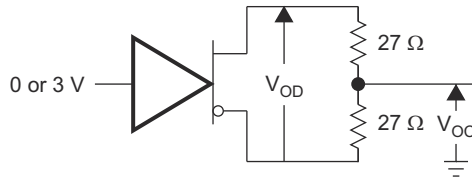

Figure 6-1. Driver V_{OD} and V_{OC}

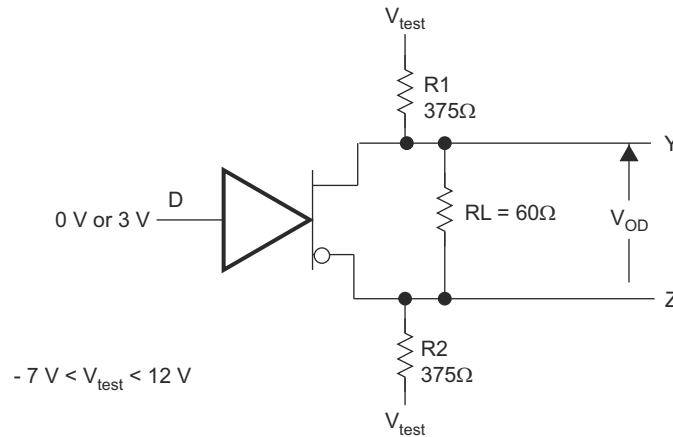
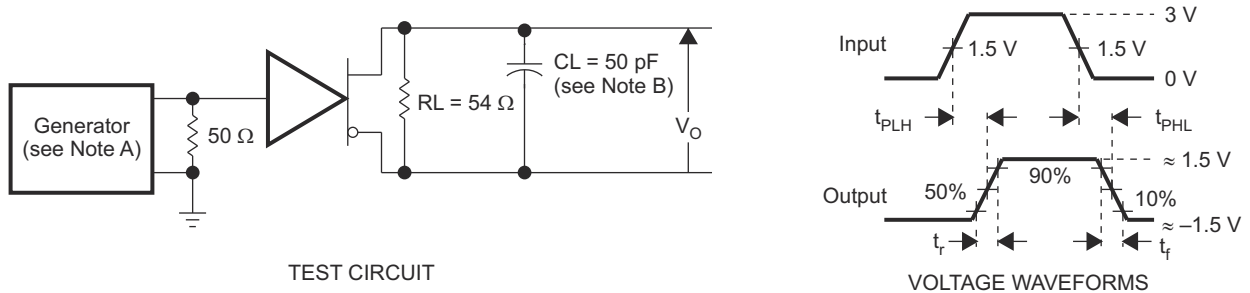
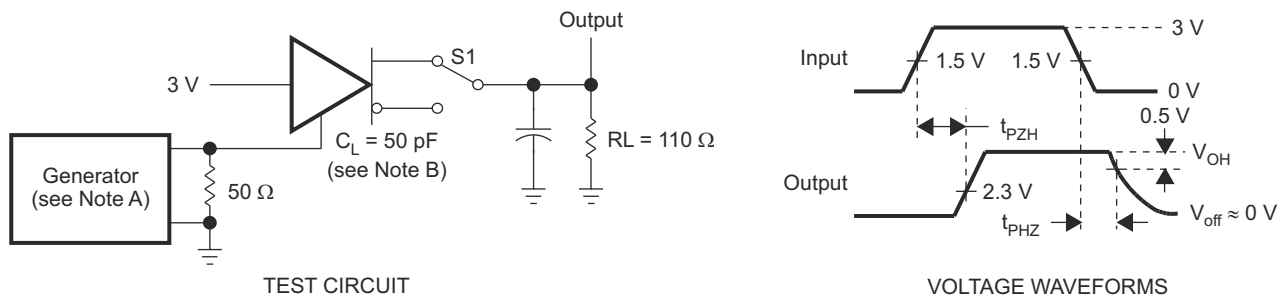

Figure 6-2. Driver V_{OD3}



- A. The input pulse is supplied by a generator having the following characteristics: $PRR \leq 1$ MHz, 50% duty cycle, $t_r \leq 6$ ns, $t_f \leq 6$ ns, $Z_0 = 50 \Omega$.
- B. C_L includes probe and jig capacitance.

Figure 6-3. Driver Test Circuit and Voltage Waveforms



- A. The input pulse is supplied by a generator having the following characteristics: $PRR \leq 1$ MHz, 50% duty cycle, $t_r \leq 6$ ns, $t_f \leq 6$ ns, $Z_0 = 50 \Omega$.
- B. C_L includes probe and jig capacitance.

Figure 6-4. Driver Test Circuit and Voltage Waveforms

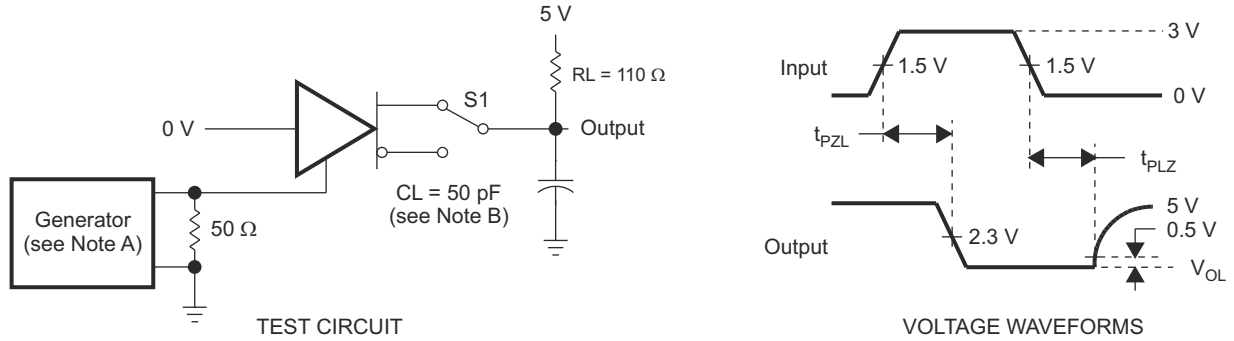

- A. The input pulse is supplied by a generator having the following characteristics: $PRR \leq 1 \text{ MHz}$, 50% duty cycle, $t_r \leq 6 \text{ ns}$, $t_f \leq 6 \text{ ns}$, $Z_O = 50\Omega$.
- B. C_L includes probe and jig capacitance.

Figure 6-5. Driver Test Circuit and Voltage Waveforms

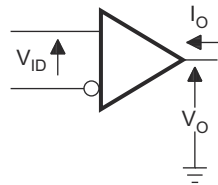
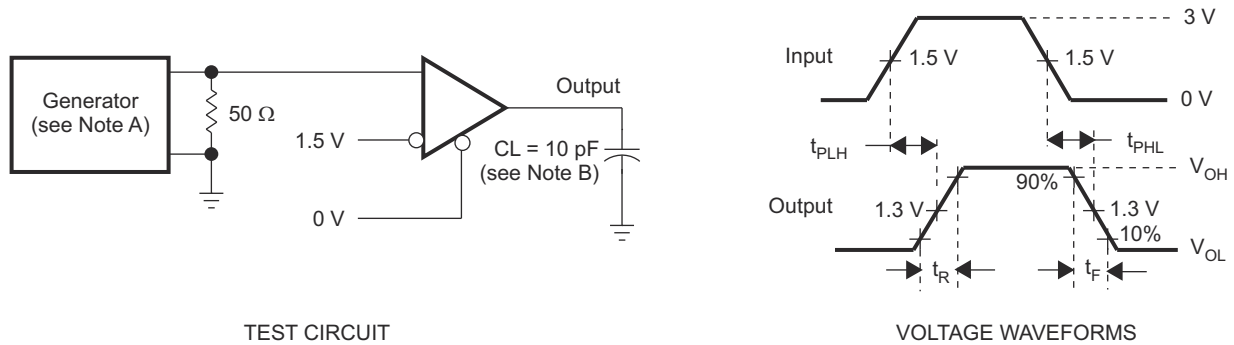
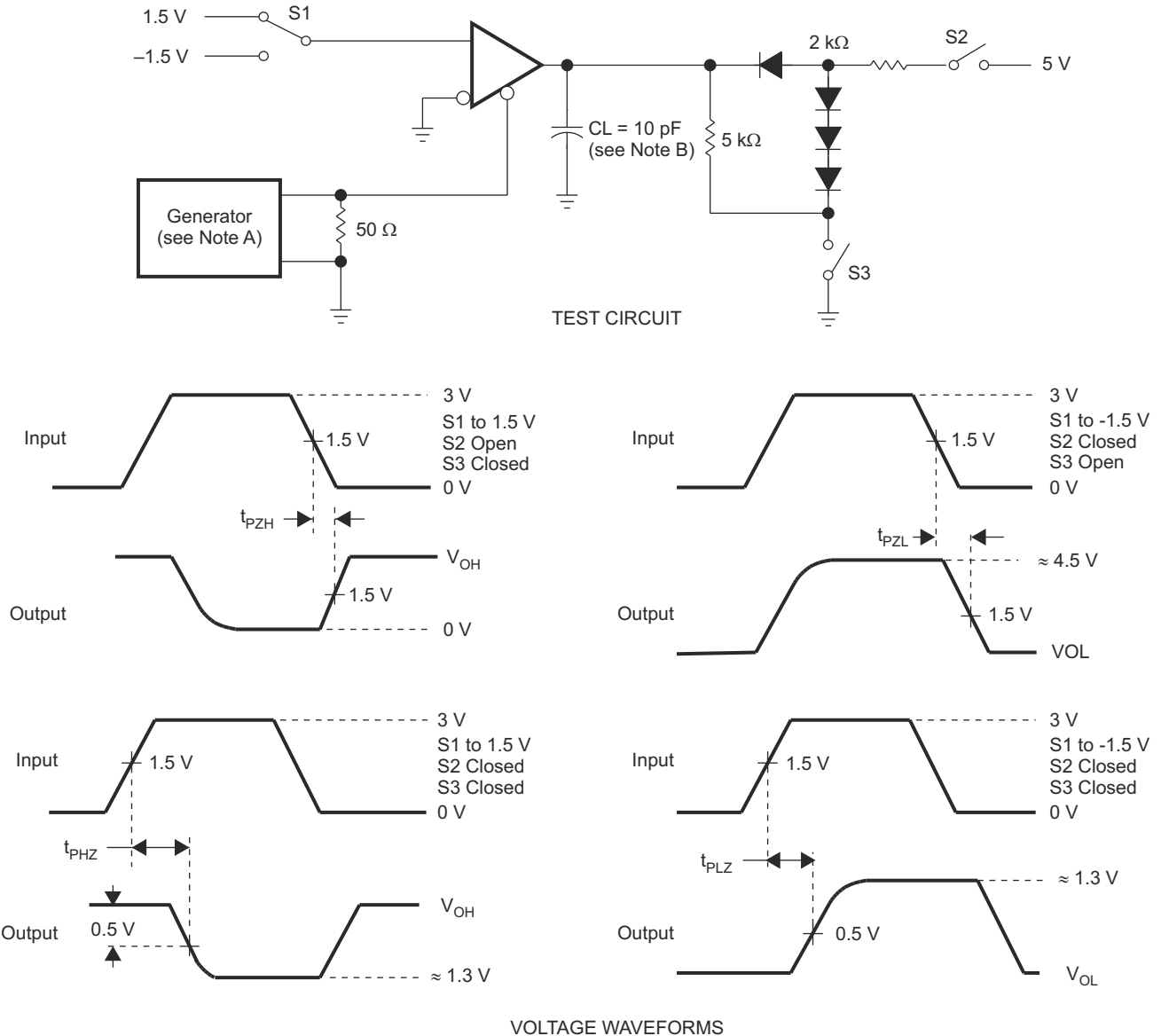

Figure 6-6. Receiver V_{OH} and V_{OL}



- A. The input pulse is supplied by a generator having the following characteristics: $PRR \leq 1 \text{ MHz}$, 50% duty cycle, $t_r \leq 6 \text{ ns}$, $t_f \leq 6 \text{ ns}$, $Z_O = 50\Omega$.
- B. C_L includes probe and jig capacitance.

Figure 6-7. Receiver Test Circuit and Voltage Waveforms



- A. The input pulse is supplied by a generator having the following characteristics: $PRR \leq 1 \text{ MHz}$, 50% duty cycle, $t_r \leq 6 \text{ ns}$, $t_f \leq 6 \text{ ns}$, $Z_O = 50\Omega$.
- B. C_L includes probe and jig capacitance.

Figure 6-8. Receiver Test Circuit and Voltage Waveforms

6 Detailed Description

6.1 Device Functional Modes

6.1.1 Function Tables

DRIVER				
INPUT D	ENABLE DE		OUTPUTS	
	A	B	A	B
H	H	L	H	L
L	H	H	L	H
X	L	L	Z	Z
Open	H	H	H	L

RECEIVER			
DIFFERENTIAL INPUTS $V_A - V_B$		ENABLE ⁽¹⁾ RE	OUTPUT ⁽¹⁾ R
$V_{ID} \geq 0.2\text{ V}$		L	H
$-0.2\text{ V} < V_{ID} < 0.2\text{ V}$		L	?
$V_{ID} \leq -0.2\text{ V}$		L	L
X		H	Z
Open		L	H

(1) H = high level, L = low level, ? = indeterminate, X = Irrelevant, Z = high impedance (off)

6.1.2 Schematics

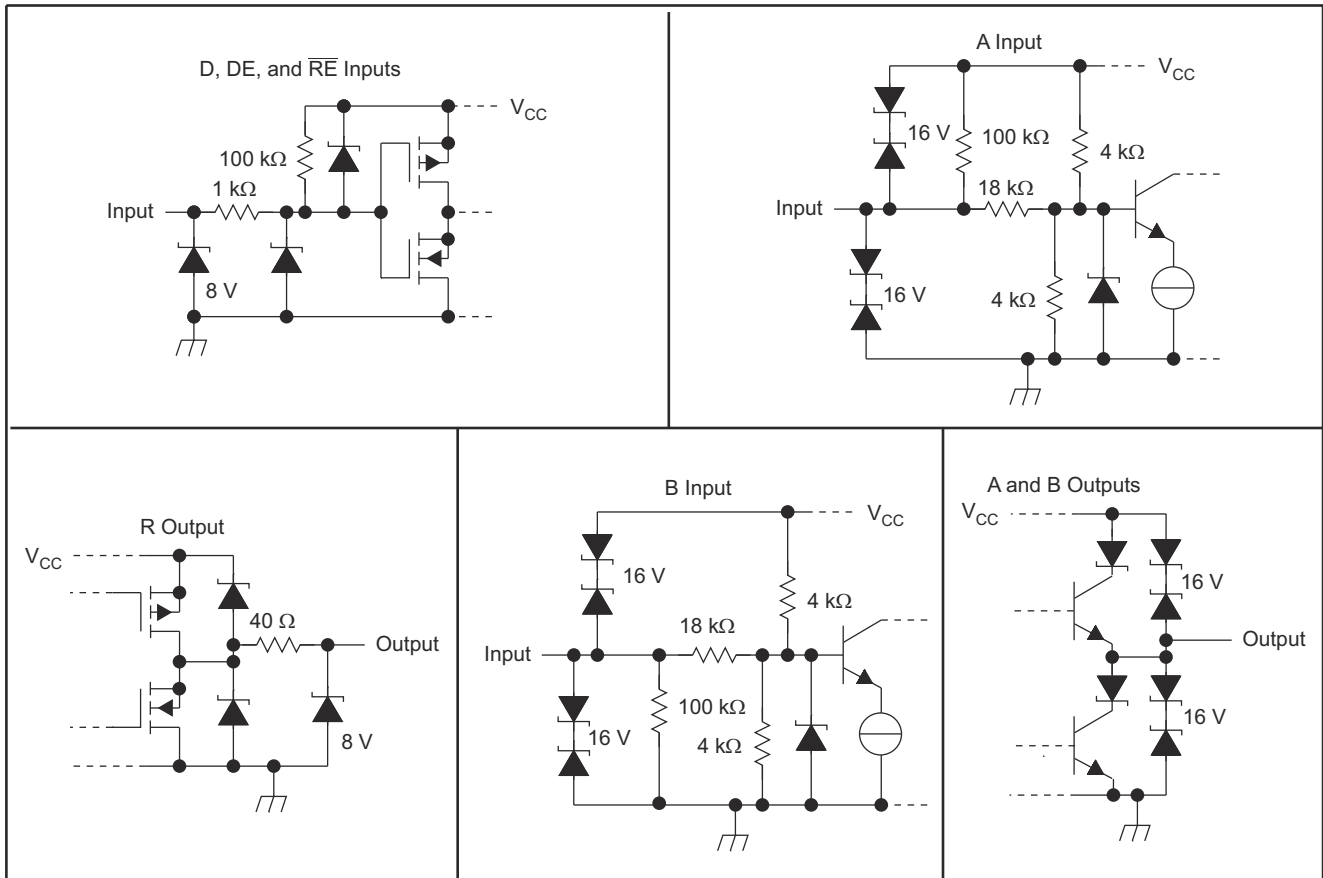

Figure 6-1. Schematics of Inputs and Outputs

7 Device and Documentation Support

7.1 Receiving Notification of Documentation Updates

To receive notification of documentation updates, navigate to the device product folder on ti.com. Click on *Subscribe to updates* to register and receive a weekly digest of any product information that has changed. For change details, review the revision history included in any revised document.

7.2 Support Resources

TI E2E™ [support forums](#) are an engineer's go-to source for fast, verified answers and design help — straight from the experts. Search existing answers or ask your own question to get the quick design help you need.

Linked content is provided "AS IS" by the respective contributors. They do not constitute TI specifications and do not necessarily reflect TI's views; see TI's [Terms of Use](#).

7.3 Trademarks

TI E2E™ is a trademark of Texas Instruments.
All trademarks are the property of their respective owners.

7.4 Electrostatic Discharge Caution



This integrated circuit can be damaged by ESD. Texas Instruments recommends that all integrated circuits be handled with appropriate precautions. Failure to observe proper handling and installation procedures can cause damage.

ESD damage can range from subtle performance degradation to complete device failure. Precision integrated circuits may be more susceptible to damage because very small parametric changes could cause the device not to meet its published specifications.

7.5 Glossary

[TI Glossary](#) This glossary lists and explains terms, acronyms, and definitions.

8 Mechanical, Packaging, and Orderable Information

The following pages include mechanical, packaging, and orderable information. This information is the most current data available for the designated devices. This data is subject to change without notice and revision of this document. For browser-based versions of this data sheet, refer to the left-hand navigation.

PACKAGING INFORMATION

Orderable Device	Status (1)	Package Type	Package Drawing	Pins	Package Qty	Eco Plan (2)	Lead finish/ Ball material (6)	MSL Peak Temp (3)	Op Temp (°C)	Device Marking (4/5)	Samples
SN65LBC176ADR	ACTIVE	SOIC	D	8	2500	RoHS & Green	NIPDAU	Level-1-260C-UNLIM	-40 to 85	BL176A	Samples
SN65LBC176AP	ACTIVE	PDIP	P	8	50	RoHS & Green	NIPDAU	N / A for Pkg Type	-40 to 85	65LBC176A	Samples
SN65LBC176AQDR	ACTIVE	SOIC	D	8	2500	RoHS & Green	NIPDAU	Level-1-260C-UNLIM	-40 to 125	B176AQ	Samples
SN75LBC176AP	ACTIVE	PDIP	P	8	50	RoHS & Green	NIPDAU	N / A for Pkg Type	0 to 70	75LBC176A	Samples

(1) The marketing status values are defined as follows:

ACTIVE: Product device recommended for new designs.

LIFEBUY: TI has announced that the device will be discontinued, and a lifetime-buy period is in effect.

NRND: Not recommended for new designs. Device is in production to support existing customers, but TI does not recommend using this part in a new design.

PREVIEW: Device has been announced but is not in production. Samples may or may not be available.

OBSELETE: TI has discontinued the production of the device.

(2) **RoHS:** TI defines "RoHS" to mean semiconductor products that are compliant with the current EU RoHS requirements for all 10 RoHS substances, including the requirement that RoHS substance do not exceed 0.1% by weight in homogeneous materials. Where designed to be soldered at high temperatures, "RoHS" products are suitable for use in specified lead-free processes. TI may reference these types of products as "Pb-Free".

RoHS Exempt: TI defines "RoHS Exempt" to mean products that contain lead but are compliant with EU RoHS pursuant to a specific EU RoHS exemption.

Green: TI defines "Green" to mean the content of Chlorine (Cl) and Bromine (Br) based flame retardants meet JS709B low halogen requirements of <=1000ppm threshold. Antimony trioxide based flame retardants must also meet the <=1000ppm threshold requirement.

(3) MSL, Peak Temp. - The Moisture Sensitivity Level rating according to the JEDEC industry standard classifications, and peak solder temperature.

(4) There may be additional marking, which relates to the logo, the lot trace code information, or the environmental category on the device.

(5) Multiple Device Markings will be inside parentheses. Only one Device Marking contained in parentheses and separated by a "-" will appear on a device. If a line is indented then it is a continuation of the previous line and the two combined represent the entire Device Marking for that device.

(6) Lead finish/Ball material - Orderable Devices may have multiple material finish options. Finish options are separated by a vertical ruled line. Lead finish/Ball material values may wrap to two lines if the finish value exceeds the maximum column width.

Important Information and Disclaimer:The information provided on this page represents TI's knowledge and belief as of the date that it is provided. TI bases its knowledge and belief on information provided by third parties, and makes no representation or warranty as to the accuracy of such information. Efforts are underway to better integrate information from third parties. TI has taken and

continues to take reasonable steps to provide representative and accurate information but may not have conducted destructive testing or chemical analysis on incoming materials and chemicals. TI and TI suppliers consider certain information to be proprietary, and thus CAS numbers and other limited information may not be available for release.

In no event shall TI's liability arising out of such information exceed the total purchase price of the TI part(s) at issue in this document sold by TI to Customer on an annual basis.

OTHER QUALIFIED VERSIONS OF SN65LBC176A :

- Enhanced Product : [SN65LBC176A-EP](#)

NOTE: Qualified Version Definitions:

- Enhanced Product - Supports Defense, Aerospace and Medical Applications

TAPE AND REEL INFORMATION

QUADRANT ASSIGNMENTS FOR PIN 1 ORIENTATION IN TAPE



*All dimensions are nominal

Device	Package Type	Package Drawing	Pins	SPQ	Reel Diameter (mm)	Reel Width W1 (mm)	A0 (mm)	B0 (mm)	K0 (mm)	P1 (mm)	W (mm)	Pin1 Quadrant
SN65LBC176ADR	SOIC	D	8	2500	330.0	12.4	6.4	5.2	2.1	8.0	12.0	Q1

TAPE AND REEL BOX DIMENSIONS

*All dimensions are nominal

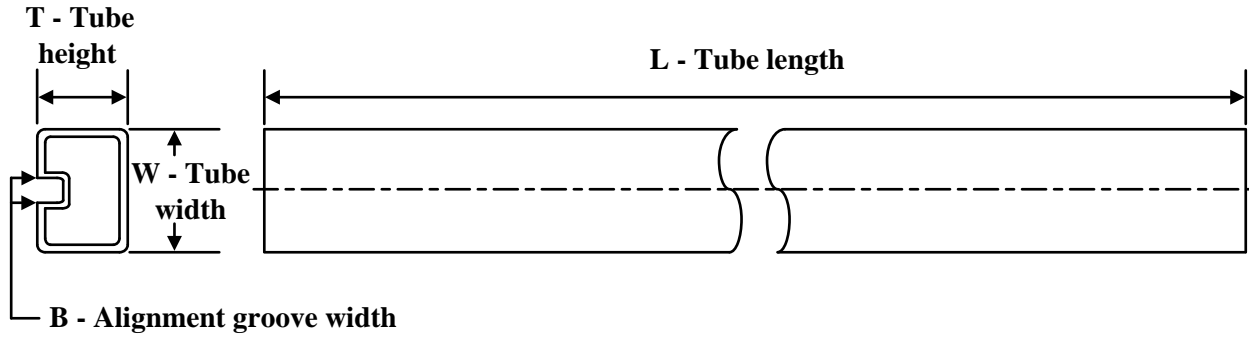
Device	Package Type	Package Drawing	Pins	SPQ	Length (mm)	Width (mm)	Height (mm)
SN65LBC176ADR	SOIC	D	8	2500	356.0	356.0	35.0

TUBE

*All dimensions are nominal

Device	Package Name	Package Type	Pins	SPQ	L (mm)	W (mm)	T (μm)	B (mm)
SN65LBC176AP	P	PDIP	8	50	506	13.97	11230	4.32
SN75LBC176AP	P	PDIP	8	50	506	13.97	11230	4.32

EXAMPLE BOARD LAYOUT

D0008A

SOIC - 1.75 mm max height

SMALL OUTLINE INTEGRATED CIRCUIT



LAND PATTERN EXAMPLE
 EXPOSED METAL SHOWN
 SCALE:8X



SOLDER MASK DETAILS

4214825/C 02/2019

NOTES: (continued)

- 6. Publication IPC-7351 may have alternate designs.
- 7. Solder mask tolerances between and around signal pads can vary based on board fabrication site.

EXAMPLE STENCIL DESIGN

D0008A

SOIC - 1.75 mm max height

SMALL OUTLINE INTEGRATED CIRCUIT



SOLDER PASTE EXAMPLE
BASED ON .005 INCH [0.125 MM] THICK STENCIL
SCALE:8X

4214825/C 02/2019

NOTES: (continued)

8. Laser cutting apertures with trapezoidal walls and rounded corners may offer better paste release. IPC-7525 may have alternate design recommendations.
9. Board assembly site may have different recommendations for stencil design.

P (R-PDIP-T8)

PLASTIC DUAL-IN-LINE PACKAGE



- NOTES:
- A. All linear dimensions are in inches (millimeters).
 - B. This drawing is subject to change without notice.
 - C. Falls within JEDEC MS-001 variation BA.

IMPORTANT NOTICE AND DISCLAIMER

TI PROVIDES TECHNICAL AND RELIABILITY DATA (INCLUDING DATA SHEETS), DESIGN RESOURCES (INCLUDING REFERENCE DESIGNS), APPLICATION OR OTHER DESIGN ADVICE, WEB TOOLS, SAFETY INFORMATION, AND OTHER RESOURCES "AS IS" AND WITH ALL FAULTS, AND DISCLAIMS ALL WARRANTIES, EXPRESS AND IMPLIED, INCLUDING WITHOUT LIMITATION ANY IMPLIED WARRANTIES OF MERCHANTABILITY, FITNESS FOR A PARTICULAR PURPOSE OR NON-INFRINGEMENT OF THIRD PARTY INTELLECTUAL PROPERTY RIGHTS.

These resources are intended for skilled developers designing with TI products. You are solely responsible for (1) selecting the appropriate TI products for your application, (2) designing, validating and testing your application, and (3) ensuring your application meets applicable standards, and any other safety, security, regulatory or other requirements.

These resources are subject to change without notice. TI grants you permission to use these resources only for development of an application that uses the TI products described in the resource. Other reproduction and display of these resources is prohibited. No license is granted to any other TI intellectual property right or to any third party intellectual property right. TI disclaims responsibility for, and you will fully indemnify TI and its representatives against, any claims, damages, costs, losses, and liabilities arising out of your use of these resources.



TI's products are provided subject to [TI's Terms of Sale](#) or other applicable terms available either on [ti.com](https://www.ti.com) or provided in conjunction with such TI products. TI's provision of these resources does not expand or otherwise alter TI's applicable warranties or warranty disclaimers for TI products.

TI objects to and rejects any additional or different terms you may have proposed.

Mailing Address: Texas Instruments, Post Office Box 655303, Dallas, Texas 75265
Copyright © 2024, Texas Instruments Incorporated

Looking for pricing, stock, or lifecycle information?

Click below to explore more details on WIN SOURCE:

-  [View SN75LBC176ADR on WIN SOURCE](#)
-  [Texas Instruments](#) Information

Optimize Your Supply Chain with WIN SOURCE Solutions

-  Global Sourcing Solution
-  Obsolete Management
-  Cost Control Management
-  Shortage Management
-  Alternative Solution
-  Excess Inventory Management