



**THE DATASHEET OF
SN75LBC031DR**



SN65LBC031, SN65LBC031Q, SN75LBC031 HIGH-SPEED CONTROLLER AREA NETWORK (CAN) TRANSCEIVERS

SLRS048A – MAY 1998 – REVISED APRIL 2000

- **SN75LBC031 Meets Standard ISO/DIS 11898 (up to 500 k Baud)**
- **Driver Output Capability at 50 mA**
- **Wide Positive and Negative Input/output Bus Voltage Range**
- **Bus Outputs Short-Circuit-Protected to Battery Voltage and Ground**
- **Thermal Shutdown**
- **Available in Q-Temp Automotive**
 - **HighRel Automotive Applications**
 - **Configuration Control/Print Support**
 - **Qualification to Automotive Standards**

description

The SN75LBC031 is a CAN transceiver used as an interface between a CAN controller and the physical bus for high speed applications of up to 500 kBaud. The device provides transmit capability to the differential bus and differential receive capability to the controller. The transmitter outputs (CANH and CANL), feature internal transition regulation to provide controlled symmetry resulting in low EMI emissions. Both transmitter outputs are fully protected against battery short circuits and electrical transients that can occur on the bus lines. In the event of excessive device power dissipation the output drivers are disabled by the thermal shutdown circuitry at a junction temperature of approximately 160°C. The inclusion of an internal pullup resistor on the transmitter input ensures a defined output during power up and protocol controller reset. For normal operation at 500 kBaud the ASC terminal is open or tied to GND. For slower speed operation at 125 kBaud the bus output transition times can be increased to reduce EMI by connecting the ASC terminal to V_{CC}. The receiver includes an integrated filter that suppresses the signal into pulses less than 30 ns wide.

The SN75LBC031 is characterized for operation from –40°C to 85°C. The SN65LBC031 is characterized for operation from –40°C to 125°C. The SN65LBC031Q is characterized for operation over the automotive temperature range of –40°C to 125°C.

**D PACKAGE
(TOP VIEW)**

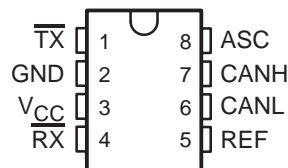

TERMINAL FUNCTIONS

TERMINAL	DESCRIPTION
$\overline{\text{TX}}$	Transmitter input
GND	Ground
V _{CC}	Supply voltage
$\overline{\text{RX}}$	Receiver output
REF	Reference output
CANL	Low side bus output driver
CANH	High side bus output driver
ASC	Adjustable slope control

FUNCTION TABLE

$\overline{\text{TX}}$	CANH	CANL	BUS STATE	$\overline{\text{RX}}$
L	H	L	Dominant	L
High or floating	Floating	Floating	Recessive	H

L = low, H = high



Please be aware that an important notice concerning availability, standard warranty, and use in critical applications of Texas Instruments semiconductor products and disclaimers thereto appears at the end of this data sheet.

PRODUCTION DATA information is current as of publication date. Products conform to specifications per the terms of Texas Instruments standard warranty. Production processing does not necessarily include testing of all parameters.

**TEXAS
INSTRUMENTS**

POST OFFICE BOX 655303 • DALLAS, TEXAS 75265

Copyright © 2000, Texas Instruments Incorporated

SN65LBC031, SN65LBC031Q, SN75LBC031 HIGH-SPEED CONTROLLER AREA NETWORK (CAN) TRANSCEIVERS

SLRS048A – MAY 1998 – REVISED APRIL 2000

logic diagram

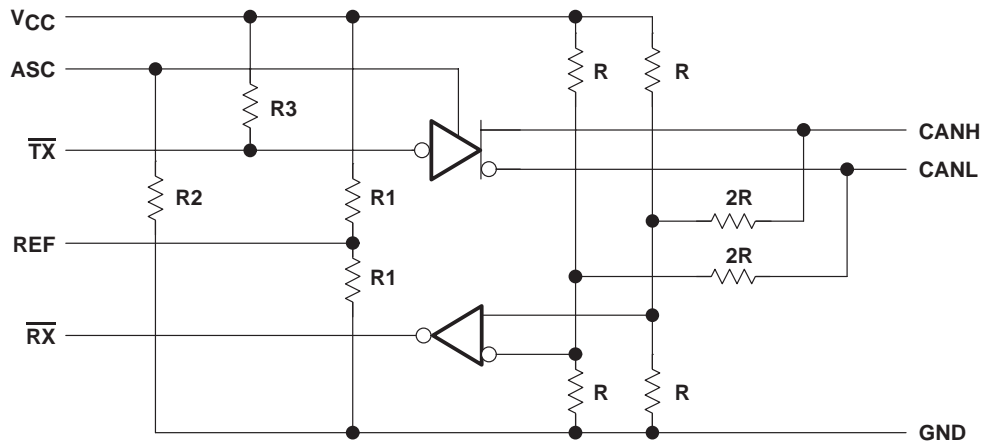

SN65LBC031, SN65LBC031Q, SN75LBC031 HIGH-SPEED CONTROLLER AREA NETWORK (CAN) TRANSCEIVERS

SLRS048A – MAY 1998 – REVISED APRIL 2000

absolute maximum ratings over operating free-air temperature range (unless otherwise noted)†

Logic supply voltage, V_{CC} (see Note 1)	7 V
Bus terminal voltage	-5 V to 20 V
Input current at \overline{TX} and ASC terminal, I_I	± 10 mA
Input voltage at \overline{TX} and ASC terminal, V_I	$2 \times V_{CC}$
Operating free-air temperature range, T_A : SN65LBC031, SN65LBC031Q	-40°C to 125°C
SN75LBC031	-40°C to 85°C
Operating junction range, T_J	-40°C to 150°C
Continuous total power dissipation at (or below) 25°C free-air temperature	See Dissipation Rating Table
Storage temperature range, T_{stg}	-65°C to 150°C
Case temperature for 10 sec T_C , D package	260°C

† Stresses beyond those listed under “absolute maximum ratings” may cause permanent damage to the device. These are stress ratings only, and functional operation of the device at these or any other conditions beyond those indicated under “recommended operating conditions” is not implied. Exposure to absolute-maximum-rated conditions for extended periods may affect device reliability.

NOTE 1: All voltage values, except differential bus voltage, are measured with respect to GND.

DISSIPATION RATING TABLE

PACKAGE	$T_A \leq 25^\circ\text{C}$ POWER RATING	OPERATING FACTOR ABOVE $T_C = 25^\circ\text{C}$	$T_C = 125^\circ\text{C}$ POWER RATING
D	725 mW	5.8 mW/°C	145 mW

**DISSIPATION DERATING CURVE
vs
FREE-AIR TEMPERATURE**

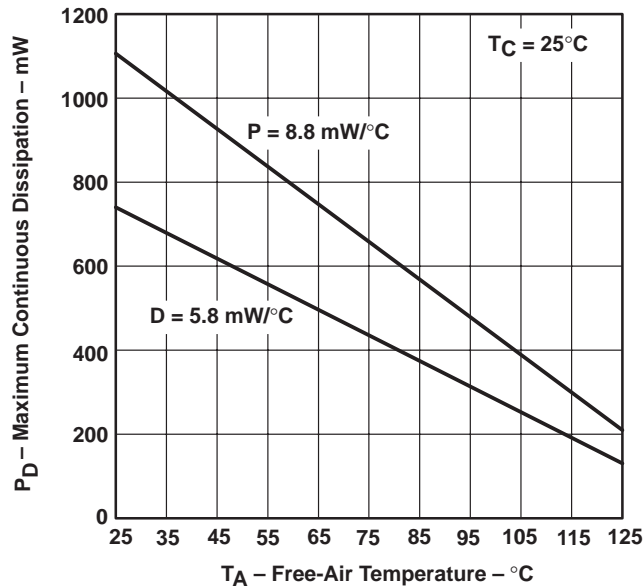

Figure 1

SN65LBC031, SN65LBC031Q, SN75LBC031 HIGH-SPEED CONTROLLER AREA NETWORK (CAN) TRANSCEIVERS

SLRS048A – MAY 1998 – REVISED APRIL 2000

recommended operating conditions

		MIN	NOM	MAX	UNIT
Logic supply voltage, V_{CC}		4.5	5	5.5	V
Voltage at any bus terminal (separately or common mode), V_I or V_{IC} (see Note 3)		-2		7	V
High-level input voltage, V_{IH}	\overline{TX}	2		V_{CC}	V
Low-level input voltage, V_{IL}	\overline{TX}	0		0.8	V
High-level output current, I_{OH}	Transmitter			-50	mA
	Receiver			-400	μ A
Low-level output current, I_{OL}	Transmitter			50	mA
	Receiver			1	
Operating free-air temperature, T_A	SN75LBC031	-40		85	$^{\circ}$ C
	SN65LBC031, SN65LBC031Q	-40		125	

NOTES: 2. All voltage values, except differential bus voltage, are measured with respect to the ground terminal.
3. For bus voltages from -5 V to -2 V and 7 V to 20 V the receiver output is stable.

SYMBOL DEFINITION

DATA SHEET PARAMETER	DEFINITION
$V_{O(CANHR)}$	CANH bus output voltage (recessive state)
$V_{O(CANLR)}$	CANL bus output voltage (recessive state)
$V_{O(CANHD)}$	CANH bus output voltage (dominant state)
$V_{O(CANLD)}$	CANL bus output voltage (dominant state)
$V_{O(DIFFR)}$	Bus differential output voltage (recessive state)
$V_{O(DIFFD)}$	Bus differential output voltage (dominant state)
$V_I(ASC)$	Adjustable slope control input voltage

electrical characteristics over recommended ranges of supply voltage and operating free-air temperature (unless otherwise noted)

PARAMETER		TEST CONDITIONS	MIN	TYP	MAX	UNIT
$V_{O(REF)}$	Reference source output voltage	$I_{REF} = \pm 20 \mu$ A	$0.45 V_{CC}$		$0.55 V_{CC}$	V
$R_{O(REF)}$	Reference source output resistance		5		10	k Ω
$I_{CC(REC)}$	Logic supply current, recessive state	See Figure 2, S1 closed		12	20	mA
$I_{CC(DOM)}$	Logic supply current, dominant state			55	80	



SN65LBC031, SN65LBC031Q, SN75LBC031 HIGH-SPEED CONTROLLER AREA NETWORK (CAN) TRANSCEIVERS

SLRS048A – MAY 1998 – REVISED APRIL 2000

transmitter electrical characteristics over recommended ranges of supply and operating free-air temperature (unless otherwise noted)

PARAMETER		TEST CONDITIONS	MIN	TYP	MAX	UNIT
$V_{O(CANHR)}$ $V_{O(CANLR)}$	Output voltage (recessive state)	See Figure 2, S1 open	2	$0.5V_{CC}$	3	V
$V_{O(DIFFR)}$	Differential output voltage (recessive state)		-500	0	50	mV
$V_{O(CANHD)}$ $V_{O(CANLD)}$	Output voltage (dominant state)	See Figure 2, S1 closed	2.75	3.5	4.5	V
$V_{O(DIFFD)}$	Differential output voltage (dominant state)		0.5	1.5	2.25	
$I_{IH(TX)}$	High-level input current (TX)	$V_{IH} = 2.4\text{ V}$		-100	-185	μA
		$V_{IH} = V_{CC}$			± 2	
$I_{IH(ASC)}$	High-level input current (ASC)	$V_{IH} = 2.4\text{ V}$		100	165	μA
		$V_{IH} = V_{CC}$		200	340	
$I_{IL(TX)}$	Low-level input current ($\overline{\text{TX}}$)	$V_{IL} = 0.4\text{ V}$		-180	-400	μA
$I_{IL(ASC)}$	Low-level input current (ASC)	$V_{IL} = 0.4\text{ V}$		15	25	μA
$C_I(TX)$	$\overline{\text{TX}}$ input capacitance			8		pF
$I_{O(ssH)}$	CANH short circuit output current	$V_{O(CANH)} = -2\text{ V to } 20\text{ V}$		-95	-200	mA
$I_{O(ssL)}$	CANL short circuit output current	$V_{O(CANL)} = 20\text{ V to } -2\text{ V}$		140	250	mA

NOTE 2: All voltage values, except differential bus voltage, are measured with respect to the ground terminal.

transceiver dynamic characteristics over recommended operating free-air temperature range and $V_{CC} = 5\text{ V}$

PARAMETER		TEST CONDITIONS	MIN	TYP	MAX	UNIT
$t_{(loop)}$	Loop time	See Figures 2 and 3, $V_I(ASC) = 0\text{ V}$ or open circuit, S1 closed, S2 open			280	ns
		See Figures 2 and 3, $V_I(ASC) = V_{CC}$, S1 closed, S2 closed			400	ns
$SR(RD)$	Differential-output slew rate (recessive to dominant)	See Figures 2 and 4, $V_I(ASC) = 0$ or open circuit, S1 closed, S2 open		35		$\text{V}/\mu\text{s}$
		See Figures 2 and 4, $V_I(ASC) = V_{CC}$, S1 closed, S2 closed		10		$\text{V}/\mu\text{s}$
$SR(DR)$	Differential-output slew rate (dominant to recessive)	See Figures 2 and 4, $V_I(ASC) = 0$ or open circuit, S1 closed, S2 open		10		$\text{V}/\mu\text{s}$
		See Figures 2 and 4, $V_I(ASC) = V_{CC}$, S1 closed, S2 closed		10		$\text{V}/\mu\text{s}$
$t_{d(RD)}$	Differential-output delay time	See Figure 2, S1 closed		55		ns
$t_{d(DR)}$				160		ns
$t_{pd(RECRD)}$ $t_{pd(RECDR)}$	Receiver propagation delay time	See Figures 2 and 5		90		ns
				55		ns

NOTE 4: Receiver input pulse width should be $>50\text{ ns}$. Input pulses of $<30\text{ ns}$ are suppressed.



SN65LBC031, SN65LBC031Q, SN75LBC031 HIGH-SPEED CONTROLLER AREA NETWORK (CAN) TRANSCEIVERS

SLRS048A – MAY 1998 – REVISED APRIL 2000

receiver electrical characteristics over recommended ranges of common-mode input voltage, supply voltage, and operating free-air temperature (unless otherwise noted)

PARAMETER		TEST CONDITIONS	MIN	TYP	MAX	UNIT
$V_{IT(REC)}$	Differential input threshold voltage for recessive state	$V_{IC} = -2\text{ V to }7\text{ V}$			500	mV
$V_{IT(DOM)}$	Differential input threshold voltage for dominant state		900			
V_{hys}	Recessive-dominant input hysteresis		100	180		mV
$V_{OH(RX)}$	High-level output voltage	$V_{O(DIFF)} = 500\text{ mV}$, $I_{OH} = -400\text{ }\mu\text{A}$	$V_{CC} - 0.5\text{ V}$		V_{CC}	V
$V_{OL(RX)}$	Low-level output voltage	$V_{O(DIFF)} = 900\text{ mV}$, $I_{OL} = 1\text{ mA}$	0		0.5	V
$r_{I(REC)}$	CANH and CANL input resistance in recessive state	dc, no load	5		50	k Ω
$r_{I(DIFF)}$	Differential CANH and CANL input resistance in recessive state	dc, no load	10		100	k Ω
C_i	CANH and CANL input capacitance			20		pF
$C_i(DHL)$	Differential CANH and CANL input capacitance			10		pF

NOTE 2: All voltage values, except differential bus voltage, are measured with respect to the ground terminal.

PARAMETER MEASUREMENT INFORMATION

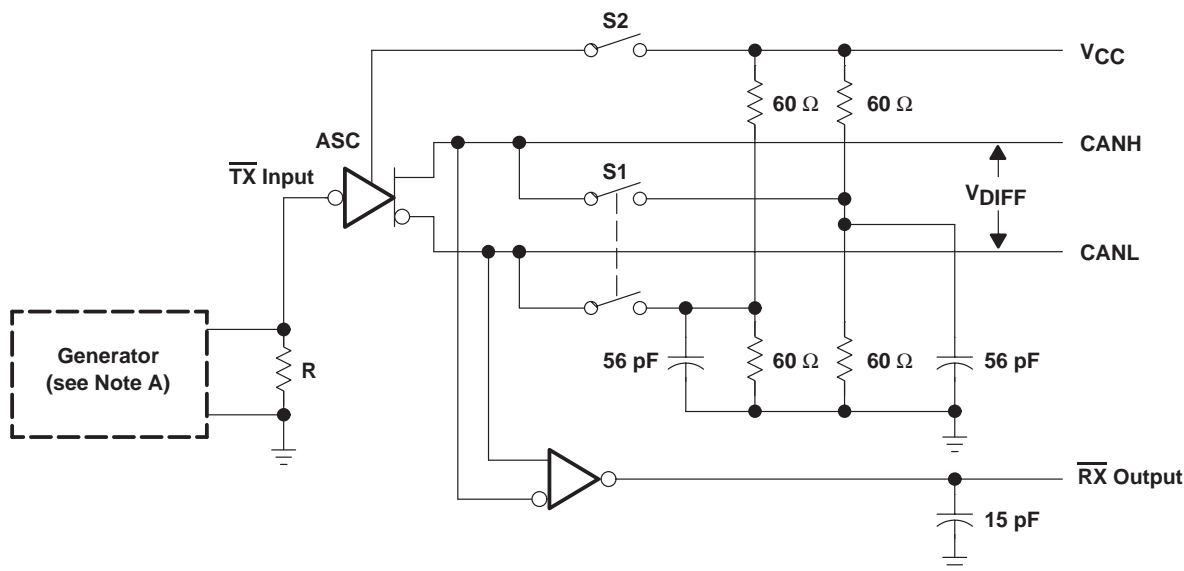

NOTE A: The input pulse is supplied to $\overline{\text{TX}}$ by a generator having a t_r and $t_f = 5\text{ ns}$.

Figure 2. Test Circuit

PARAMETER MEASUREMENT INFORMATION

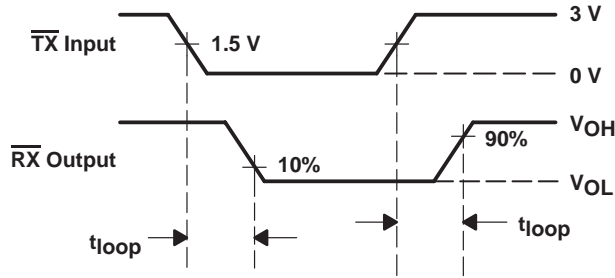

Figure 3. Loop Time

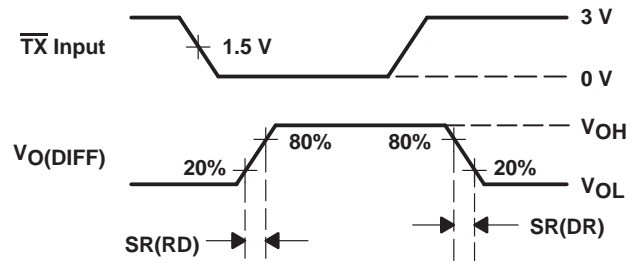
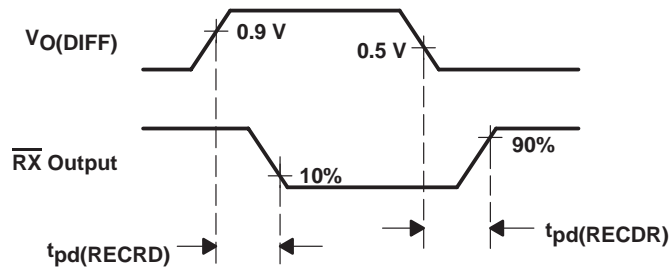

Figure 4. Slew Rate

NOTE A: The input pulse is supplied to $\overline{\text{TX}}$ by a generator having a t_r and $t_f = 5$ ns.



NOTE A: The input pulse is supplied as V_{DIFF} using CANH and CANL respectively by a generator having a t_r and $t_f = 5$ ns.

Figure 5. Receiver Delay Times

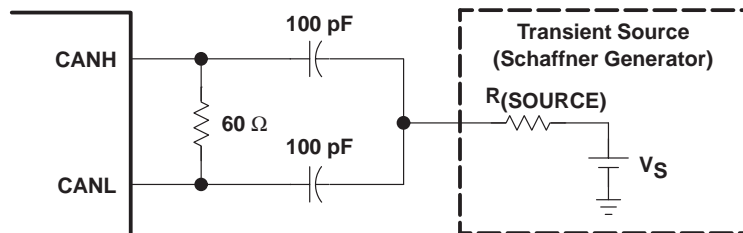

Figure 6. Transient Stress Capability Test Circuit

SN65LBC031, SN65LBC031Q, SN75LBC031 HIGH-SPEED CONTROLLER AREA NETWORK (CAN) TRANSCEIVERS

SLRS048A – MAY 1998 – REVISED APRIL 2000

PARAMETER MEASUREMENT INFORMATION

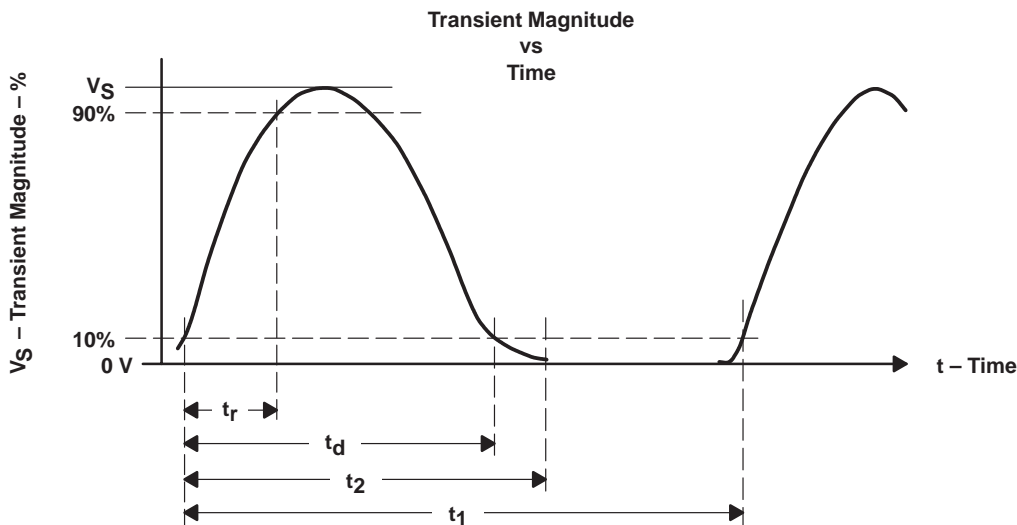

Figure 7. Transient Stress Capability Waveform

Table 1. Test Circuit Results According to DIN 40839

TEST PULSE	TRANSIENT MAGNITUDE V_S	SOURCE IMPEDANCE R_{SOURCE}	PULSE WIDTH t_d (see Note 5)	PULSE RISE TIME, t_r (see Note 6)	PULSE TIME, t_2 (see Figure 7)	REPETITION PERIOD, t_1 (see Figure 7)	NUMBER OF PULSES
1	-100 V	10 Ω	2 ms	1 μ s	200 ms	5 s	5000
2	100 V	10 Ω	50 μ s	1 μ s	200 ms	5 s	5000
3a	-150 V	50 Ω	0.1 μ s	5 ns	100 μ s	100 μ s	See Note 7
3b	100 V	50 Ω	0.1 μ s	5 ns	100 μ s	100 μ s	See Note 7
5	60 V	1 Ω	400 ms	5 ms	—	—	1

NOTES: 5. Measured from 10% on rising edge to 10% on falling edge
 6. Measured from 10% to 90% of pulse
 7. Pulse package for a period of 3600 s, 10 ms pulse time, 90 ms stop time

SN65LBC031, SN65LBC031Q, SN75LBC031 HIGH-SPEED CONTROLLER AREA NETWORK (CAN) TRANSCEIVERS

SLRS048A – MAY 1998 – REVISED APRIL 2000

APPLICATION INFORMATION

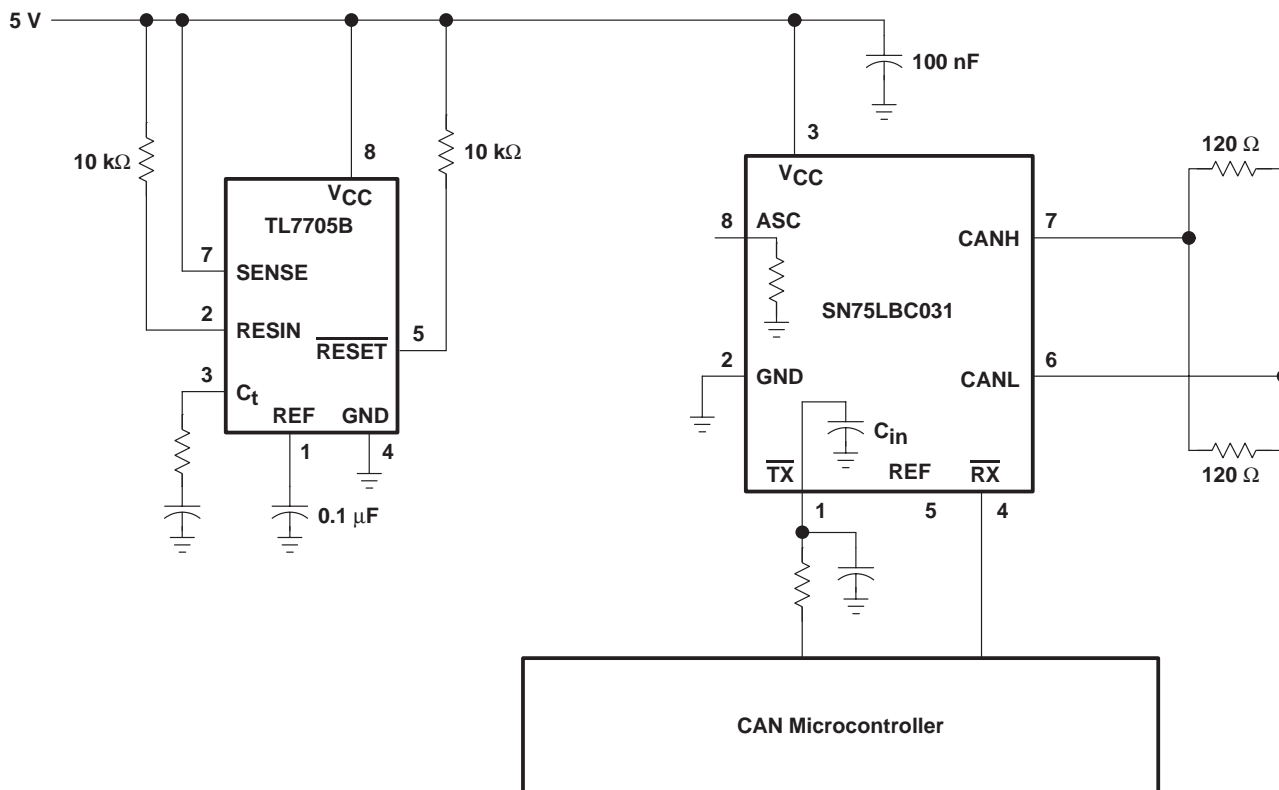

Figure 8. Typical SN75LBC031 Application

SN65LBC031, SN65LBC031Q, SN75LBC031 HIGH-SPEED CONTROLLER AREA NETWORK (CAN) TRANSCEIVERS

SLRS048A – MAY 1998 – REVISED APRIL 2000

MECHANICAL DATA

D (R-PDSO-G**)

PLASTIC SMALL-OUTLINE PACKAGE

14 PIN SHOWN

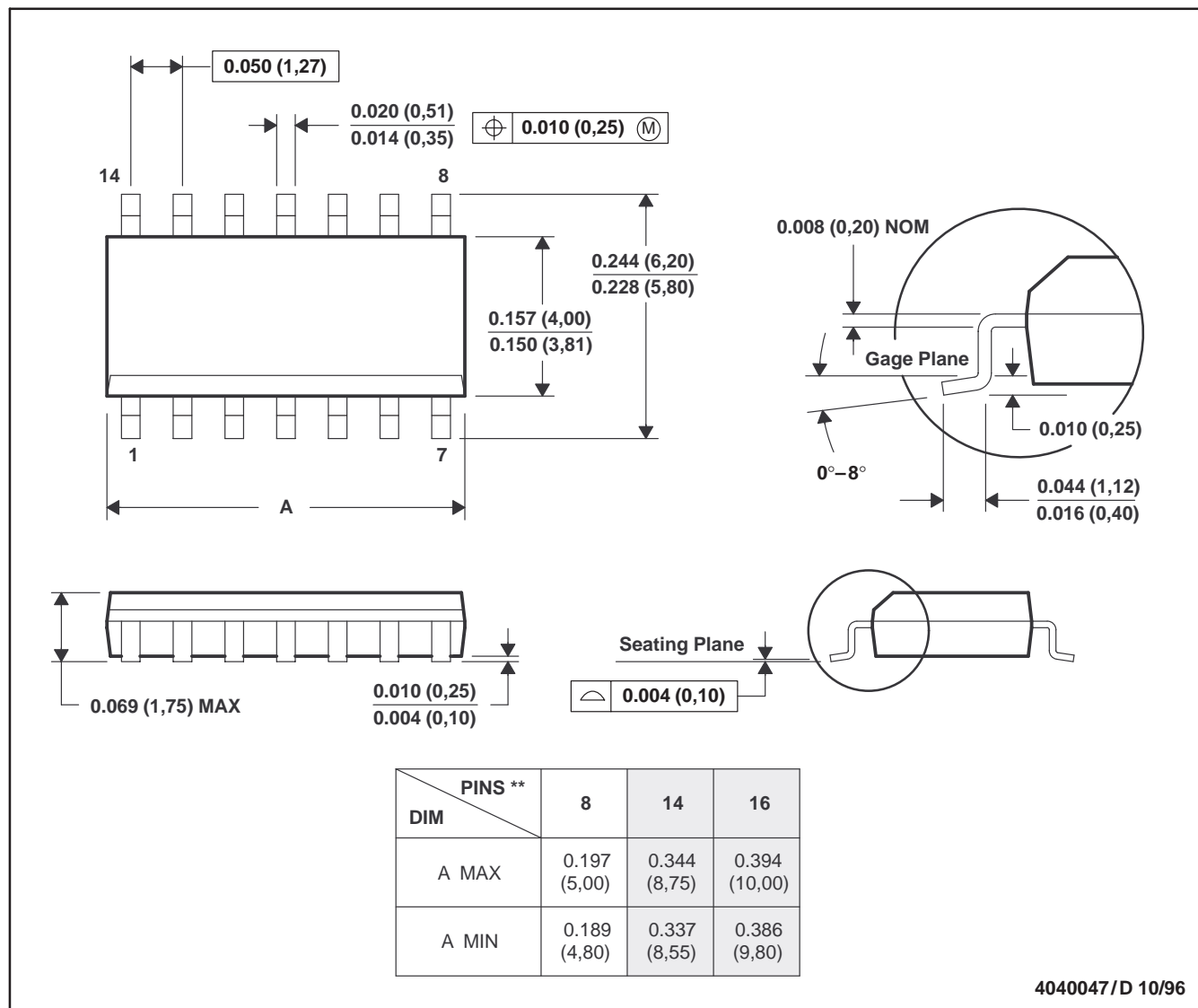

- NOTES: A. All linear dimensions are in inches (millimeters).
 B. This drawing is subject to change without notice.
 C. Body dimensions do not include mold flash or protrusion, not to exceed 0.006 (0,15).
 D. Falls within JEDEC MS-012

PACKAGING INFORMATION

Orderable Device	Status (1)	Package Type	Package Drawing	Pins	Package Qty	Eco Plan (2)	Lead/Ball Finish (6)	MSL Peak Temp (3)	Op Temp (°C)	Device Marking (4/5)	Samples
SN65LBC031D	ACTIVE	SOIC	D	8	75	TBD	CU NIPDAU	Level-1-220C-UNLIM	-40 to 85	6LB031	Samples
SN65LBC031DG4	ACTIVE	SOIC	D	8	75	Green (RoHS & no Sb/Br)	CU NIPDAU	Level-1-260C-UNLIM	-40 to 85	6LB031	Samples
SN65LBC031DRG4	ACTIVE	SOIC	D	8	2500	Green (RoHS & no Sb/Br)	CU NIPDAU	Level-1-260C-UNLIM		6LB031	Samples
SN65LBC031QD	ACTIVE	SOIC	D	8	75	Green (RoHS & no Sb/Br)	CU NIPDAU	Level-1-260C-UNLIM	-40 to 125	6LB031Q	Samples
SN65LBC031QDG4	ACTIVE	SOIC	D	8	75	Green (RoHS & no Sb/Br)	CU NIPDAU	Level-1-260C-UNLIM	-40 to 125	6LB031Q	Samples
SN65LBC031QDR	ACTIVE	SOIC	D	8	2500	Green (RoHS & no Sb/Br)	CU NIPDAU	Level-1-260C-UNLIM	-40 to 125	LB031Q	Samples
SN65LBC031QDRG4	ACTIVE	SOIC	D	8	2500	Green (RoHS & no Sb/Br)	CU NIPDAU	Level-1-260C-UNLIM	-40 to 125	LB031Q	Samples
SN75LBC031D	ACTIVE	SOIC	D	8	75	Green (RoHS & no Sb/Br)	CU NIPDAU	Level-1-260C-UNLIM	0 to 70	7LB031	Samples
SN75LBC031DR	ACTIVE	SOIC	D	8	2500	Green (RoHS & no Sb/Br)	CU NIPDAU	Level-1-260C-UNLIM	0 to 70	7LB031	Samples

(1) The marketing status values are defined as follows:

ACTIVE: Product device recommended for new designs.

LIFEBUY: TI has announced that the device will be discontinued, and a lifetime-buy period is in effect.

NRND: Not recommended for new designs. Device is in production to support existing customers, but TI does not recommend using this part in a new design.

PREVIEW: Device has been announced but is not in production. Samples may or may not be available.

OBSOLETE: TI has discontinued the production of the device.

(2) Eco Plan - The planned eco-friendly classification: Pb-Free (RoHS), Pb-Free (RoHS Exempt), or Green (RoHS & no Sb/Br) - please check <http://www.ti.com/productcontent> for the latest availability information and additional product content details.

TBD: The Pb-Free/Green conversion plan has not been defined.

Pb-Free (RoHS): TI's terms "Lead-Free" or "Pb-Free" mean semiconductor products that are compatible with the current RoHS requirements for all 6 substances, including the requirement that lead not exceed 0.1% by weight in homogeneous materials. Where designed to be soldered at high temperatures, TI Pb-Free products are suitable for use in specified lead-free processes.

Pb-Free (RoHS Exempt): This component has a RoHS exemption for either 1) lead-based flip-chip solder bumps used between the die and package, or 2) lead-based die adhesive used between the die and leadframe. The component is otherwise considered Pb-Free (RoHS compatible) as defined above.

Green (RoHS & no Sb/Br): TI defines "Green" to mean Pb-Free (RoHS compatible), and free of Bromine (Br) and Antimony (Sb) based flame retardants (Br or Sb do not exceed 0.1% by weight in homogeneous material)

(3) MSL, Peak Temp. - The Moisture Sensitivity Level rating according to the JEDEC industry standard classifications, and peak solder temperature.

(4) There may be additional marking, which relates to the logo, the lot trace code information, or the environmental category on the device.

(5) Multiple Device Markings will be inside parentheses. Only one Device Marking contained in parentheses and separated by a "~" will appear on a device. If a line is indented then it is a continuation of the previous line and the two combined represent the entire Device Marking for that device.

(6) Lead/Ball Finish - Orderable Devices may have multiple material finish options. Finish options are separated by a vertical ruled line. Lead/Ball Finish values may wrap to two lines if the finish value exceeds the maximum column width.

Important Information and Disclaimer:The information provided on this page represents TI's knowledge and belief as of the date that it is provided. TI bases its knowledge and belief on information provided by third parties, and makes no representation or warranty as to the accuracy of such information. Efforts are underway to better integrate information from third parties. TI has taken and continues to take reasonable steps to provide representative and accurate information but may not have conducted destructive testing or chemical analysis on incoming materials and chemicals. TI and TI suppliers consider certain information to be proprietary, and thus CAS numbers and other limited information may not be available for release.

In no event shall TI's liability arising out of such information exceed the total purchase price of the TI part(s) at issue in this document sold by TI to Customer on an annual basis.

TAPE AND REEL INFORMATION



QUADRANT ASSIGNMENTS FOR PIN 1 ORIENTATION IN TAPE



*All dimensions are nominal

Device	Package Type	Package Drawing	Pins	SPQ	Reel Diameter (mm)	Reel Width W1 (mm)	A0 (mm)	B0 (mm)	K0 (mm)	P1 (mm)	W (mm)	Pin1 Quadrant
SN65LBC031QDR	SOIC	D	8	2500	330.0	12.4	6.4	5.2	2.1	8.0	12.0	Q1
SN65LBC031QDRG4	SOIC	D	8	2500	330.0	12.4	6.4	5.2	2.1	8.0	12.0	Q1
SN75LBC031DR	SOIC	D	8	2500	330.0	12.4	6.4	5.2	2.1	8.0	12.0	Q1

TAPE AND REEL BOX DIMENSIONS

*All dimensions are nominal

Device	Package Type	Package Drawing	Pins	SPQ	Length (mm)	Width (mm)	Height (mm)
SN65LBC031QDR	SOIC	D	8	2500	350.0	350.0	43.0
SN65LBC031QDRG4	SOIC	D	8	2500	350.0	350.0	43.0
SN75LBC031DR	SOIC	D	8	2500	350.0	350.0	43.0



D0008A

PACKAGE OUTLINE

SOIC - 1.75 mm max height

SMALL OUTLINE INTEGRATED CIRCUIT



4214825/C 02/2019

NOTES:

1. Linear dimensions are in inches [millimeters]. Dimensions in parenthesis are for reference only. Controlling dimensions are in inches. Dimensioning and tolerancing per ASME Y14.5M.
2. This drawing is subject to change without notice.
3. This dimension does not include mold flash, protrusions, or gate burrs. Mold flash, protrusions, or gate burrs shall not exceed $.006$ [0.15] per side.
4. This dimension does not include interlead flash.
5. Reference JEDEC registration MS-012, variation AA.

EXAMPLE BOARD LAYOUT

D0008A

SOIC - 1.75 mm max height

SMALL OUTLINE INTEGRATED CIRCUIT



LAND PATTERN EXAMPLE
 EXPOSED METAL SHOWN
 SCALE:8X



SOLDER MASK DETAILS

4214825/C 02/2019

NOTES: (continued)

- 6. Publication IPC-7351 may have alternate designs.
- 7. Solder mask tolerances between and around signal pads can vary based on board fabrication site.

EXAMPLE STENCIL DESIGN

D0008A

SOIC - 1.75 mm max height

SMALL OUTLINE INTEGRATED CIRCUIT



SOLDER PASTE EXAMPLE
BASED ON .005 INCH [0.125 MM] THICK STENCIL
SCALE:8X

4214825/C 02/2019

NOTES: (continued)

8. Laser cutting apertures with trapezoidal walls and rounded corners may offer better paste release. IPC-7525 may have alternate design recommendations.
9. Board assembly site may have different recommendations for stencil design.

IMPORTANT NOTICE AND DISCLAIMER

TI PROVIDES TECHNICAL AND RELIABILITY DATA (INCLUDING DATASHEETS), DESIGN RESOURCES (INCLUDING REFERENCE DESIGNS), APPLICATION OR OTHER DESIGN ADVICE, WEB TOOLS, SAFETY INFORMATION, AND OTHER RESOURCES "AS IS" AND WITH ALL FAULTS, AND DISCLAIMS ALL WARRANTIES, EXPRESS AND IMPLIED, INCLUDING WITHOUT LIMITATION ANY IMPLIED WARRANTIES OF MERCHANTABILITY, FITNESS FOR A PARTICULAR PURPOSE OR NON-INFRINGEMENT OF THIRD PARTY INTELLECTUAL PROPERTY RIGHTS.

These resources are intended for skilled developers designing with TI products. You are solely responsible for (1) selecting the appropriate TI products for your application, (2) designing, validating and testing your application, and (3) ensuring your application meets applicable standards, and any other safety, security, or other requirements. These resources are subject to change without notice. TI grants you permission to use these resources only for development of an application that uses the TI products described in the resource. Other reproduction and display of these resources is prohibited. No license is granted to any other TI intellectual property right or to any third party intellectual property right. TI disclaims responsibility for, and you will fully indemnify TI and its representatives against, any claims, damages, costs, losses, and liabilities arising out of your use of these resources.

TI's products are provided subject to TI's Terms of Sale (www.ti.com/legal/termsofsale.html) or other applicable terms available either on ti.com or provided in conjunction with such TI products. TI's provision of these resources does not expand or otherwise alter TI's applicable warranties or warranty disclaimers for TI products.

Mailing Address: Texas Instruments, Post Office Box 655303, Dallas, Texas 75265
Copyright © 2019, Texas Instruments Incorporated

Looking for pricing, stock, or lifecycle information?

Click below to explore more details on WIN SOURCE:

 [View SN75LBC031DR](#) on WIN SOURCE

 [Texas Instruments](#) Information

Optimize Your Supply Chain with WIN SOURCE Solutions

-  Global Sourcing Solution
-  Obsolete Management
-  Cost Control Management
-  Shortage Management
-  Alternative Solution
-  Excess Inventory Management