



**THE DATASHEET OF
SN75ALS1177NSR**



SN75ALS1177, SN75ALS1178 Dual Differential Drivers and Receivers

1 Features

- Meet or exceed standards TIA/EIA-422-B and TIA/EIA-485-A
- Designed for multipoint bus transmission on long bus lines in noisy environments
- Low supply-current requirement 50mA maximum
- Driver positive-and negative-current limiting
- Driver common-mode output voltage range of -7V to 12V
- Thermal shutdown protection driver 3-state outputs active-high enable
- Receiver common-mode input voltage range of -12V to 12V
- Receiver input sensitivity: $\pm 200\text{mV}$
- Receiver hysteresis: 50mV typical
- Receiver high input impedance: 12k Ω minimum
- Receiver 3-state outputs active-low enable for SN75ALS1177 only
- Operate from single 5V supply

2 Applications

- [Motor Drives](#)
- [Factory Automation](#)
- [Building Automation](#)

3 Description

The SN75ALS1177 and SN75ALS1178 dual differential drivers and receivers are integrated circuits designed for bidirectional data communication on multipoint bus transmission lines. The devices are designed for balanced transmission lines, and meet standards TIA/EIA-422-B and TIA/EIA-485-A.

The SN75ALS1177 combines dual 3-state differential line drivers and dual 3-state differential input line receivers, both of which operate from a single 5V power supply. The drivers and receivers have active-high and active-low enables, respectively, which can be externally connected together to function as direction control. The SN75ALS1178 drivers each have an individual active-high enable. Fail-safe design ensures that when the receiver inputs are open, the receiver outputs are always high.

The SN75ALS1177 and SN75ALS1178 are characterized for operation from 0°C to 70°C.

Package Options

PART NUMBER	PACKAGE ⁽¹⁾	PACKAGE SIZE ⁽²⁾
SN75ALS1177	SOP (NS, 16)	10.2mm × 7.8mm
SN75ALS1178	PDIP (N, 16)	19.3mm × 9.4mm

(1) For more information, see [Section 10](#).

(2) The package size (length × width) is a nominal value and includes pins, where applicable.

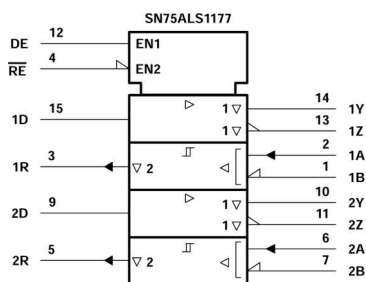

Logic Symbol[†]

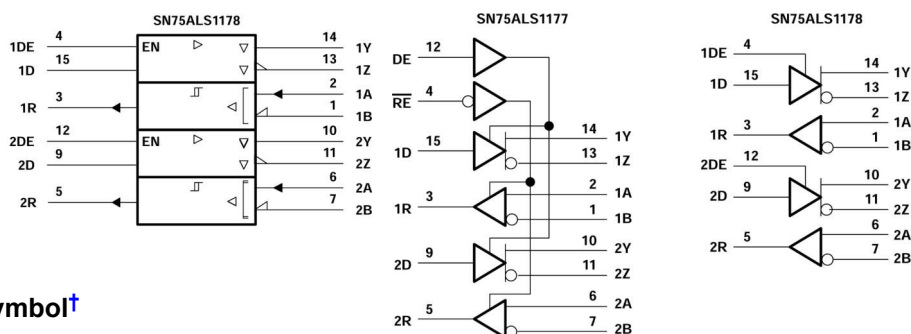

Logic Diagram (Positive Logic)

[†] These symbols are in accordance with ANSI/IEEE Std 91-1984 and IEC Publication 617-12.



Table of Contents

1 Features	1	7.1 Device Functional Modes.....	11
2 Applications	1	8 Device and Documentation Support	13
3 Description	1	8.1 Documentation Support.....	13
4 Pin Configuration and Functions	3	8.2 Receiving Notification of Documentation Updates....	13
5 Specifications	5	8.3 Support Resources.....	13
5.1 Absolute Maximum Ratings.....	5	8.4 Trademarks.....	13
5.2 Recommended Operating Conditions.....	5	8.5 Electrostatic Discharge Caution.....	13
5.3 Thermal Information.....	5	8.6 Glossary.....	13
5.4 Driver Section.....	6	9 Revision History	13
5.5 Receiver Section.....	7	10 Mechanical, Packaging, and Orderable Information	13
6 Parameter Measurement Information	8		
7 Detailed Description	11		

4 Pin Configuration and Functions

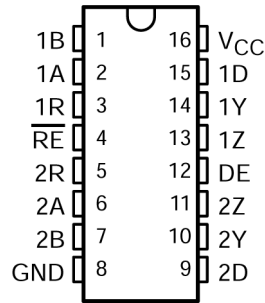

**Figure 4-1. SN75ALS1177: N or NS Package
(Top View)**

NAME	PIN		TYPE	DESCRIPTION
	SO	TSSOP		
1A	2	2	I	RS422 differential input (non-inverting) to receiver 1
2A	6	6	I	RS422 differential input (non-inverting) to receiver 2
1B	1	1	I	RS422 differential input (inverting) to receiver 1
2B	7	7	I	RS422 differential input (inverting) to receiver 2
1D	15	15	I	Logic data input to RS422 driver 1
2D	9	9	I	Logic data input to RS422 driver 2
DE	12	12	I	Driver enable (active high)
GND	8	8	—	Device ground pin
1R	3	3	O	Logic data output of RS422 receiver 1
2R	5	5	O	Logic data output of RS422 receiver 2
RE	4	4	I	Receiver enable pin (active low)
V _{CC}	16	16	—	Power supply
1Y	14	14	O	RS-422 differential (non-inverting) driver output 1
2Y	10	10	O	RS-422 differential (non-inverting) driver output 2
1Z	13	13	O	RS-422 differential (inverting) driver output 1
2Z	11	11	O	RS-422 differential (inverting) driver output 2

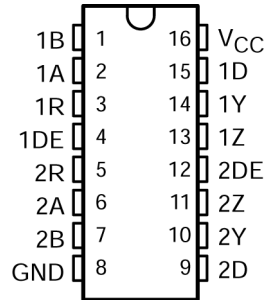

Figure 4-2. SN75ALS1178: N or NS Package (Top View)

PINT			TYPE	DESCRIPTION
NAME	SO	TSSOP		
1A	2	2	I	RS422 differential input (non-inverting) to receiver 1
2A	6	6	I	RS422 differential input (non-inverting) to receiver 2
1B	1	1	I	RS422 differential input (inverting) to receiver 1
2B	7	7	I	RS422 differential input (inverting) to receiver 2
1D	15	15	I	Logic data input to RS422 driver 1
2D	9	9	I	Logic data input to RS422 driver 2
1DE	4	4	I	Driver 1 enable (active high)
2DE	12	12	I	Driver 2 enable (active high)
GND	8	8	—	Device ground
1R	3	3	O	Logic data output of RS422 receiver 1
2R	5	5	O	Logic data output of RS422 receiver 2
V _{CC}	16	16	—	Power supply
1Y	14	14	O	RS-422 differential (non-inverting) driver output 1
2Y	10	10	O	RS-422 differential (non-inverting) driver output 2
1Z	13	13	O	RS-422 differential (non-inverting) driver output 1
2Z	11	11	O	RS-422 differential (non-inverting) driver output 2

5 Specifications

5.1 Absolute Maximum Ratings

over operating free-air temperature range (unless otherwise noted)⁽¹⁾

		MIN	MAX	UNIT
V _{CC}	Supply voltage, (see ⁽²⁾)		7	V
V _I	Input voltage, (DE, RE, and D inputs)		7	V
V _O	Output voltage range, drivers	-9	14	V
	Input voltage range, receiver	-14	14	V
	Receiver differential-input voltage range, (see ⁽³⁾)	-14	14	V
	Receiver low-level output current		50	mA
	Lead temperature 1,6 mm (1/16 inch) from case for 10 seconds		260	°C
T _{stg}	Storage temperature range	-65	150	°C

- (1) Stresses beyond those listed under “absolute maximum ratings” may cause permanent damage to the device. These are stress ratings only, and functional operation of the device at these or any other conditions beyond those indicated under “recommended operating conditions” is not implied. Exposure to absolute-maximum-rated conditions for extended periods may affect device reliability.
- (2) All voltage values, except differential input voltage, are with respect to the network ground terminal.
- (3) Differential input voltage is measured at the noninverting terminal with respect to the inverting terminal.

5.2 Recommended Operating Conditions

			MIN	NOM	MAX	UNIT
V _{CC}	Supply voltage		4.75	5	5.25	V
V _{ID}	Differential input voltage	Receiver			±12	V
V _{OC}	Common-mode output voltage	Driver	-7 ⁽¹⁾		12	V
V _{IC}	Common-mode input voltage	Receiver			±12	V
V _{IH}	High-level input voltage	DE, RE, D	2			V
V _{IL}	Low-level input voltage	DE, RE, D			0.8	V
I _{OH}	High-level output current	Driver			-60	mA
		Receiver			-400	µA
I _{OL}	Low - level out output current	Driver			60	mA
		Receiver			8	mA
T _A	Operating free-air temperature		0		70	°C

- (1) The algebraic convention, where the less positive (more negative) limit is designated as minimum, is used in this data sheet for common-mode output and threshold voltage level only.

5.3 Thermal Information

THERMAL METRIC ⁽¹⁾		PDIP (N)	SO (NS)	UNIT
		16 Pins	16 Pins	
R _{θJA}	Junction-to-ambient thermal resistance (see ⁽²⁾)	60.6	88.5	°C/W
R _{θJB}	Junction-to-board thermal resistance	48.1	46.2	°C/W
ψ _{JT}	Junction-to-top characterization parameter	40.6	50.7	°C/W
ψ _{JB}	Junction-to-board characterization parameter	27.5	13.5	°C/W
R _{θJC(bot)}	Junction-to-case (bottom) thermal resistance	40.3	50.3	°C/W

- (1) For more information about traditional and new thermal metrics, see the [Semiconductor and IC package thermal metrics](#) application report.
- (2) The package thermal impedance is calculated in accordance with JESD 51-7.

5.4 Driver Section

5.4.1 Electrical Characteristics

over recommended ranges of supply voltage and operating free-air temperature (unless otherwise noted)

PARAMETER		TEST CONDITIONS			MIN	TYP ⁽¹⁾	MAX	UNIT
V _{IK}	Input clamp voltage	I _I = -18 mA					-1.5	V
V _{OH}	High-level output voltage	V _{IH} = 2V,	V _{IL} = 0.8V,	I _{OH} = -33mA		3.3		V
V _{OL}	Low-level output voltage	V _{IH} = 2V,	V _{IL} = 0.8V,	I _{OL} = 33mA		1.1		V
V _{OD1}	Differential output voltage	I _O = 0			1.5		6	V
V _{OD2}	Differential output voltage	V _{CC} = 5V,	R _L = 100Ω,	See Figure 6-1	1/2V _{OD1} or 2 ⁽²⁾			V
		R _L = 54Ω,	See Figure 6-1		1.5	2.5	5	
V _{OD3}	Differential output voltage	See Note 4			1.5		5	V
Δ V _{OD}	Change in magnitude of differential output voltage (see Note 5)	R _L = 54Ω or 100Ω,		See Figure 6-1			±0.2	V
V _{OC}	Common-mode output voltage	R _L = 54Ω or 100Ω,		See Figure 6-1	-1 ⁽³⁾		3	V
Δ V _{OC}	Change in magnitude of common-mode output voltage (see Note 5)	R _L = 54Ω or 100Ω,		See Figure 6-1			±0.2	V
I _{O(OFF)}	Output current with power off	V _{CC} = 0,	V _O = -7V to 12V				±100	μA
I _{OZ}	High-impedance-state output current	V _O = -7V to 12V					±100	μA
I _{IH}	High-level input current	V _{IH} = 2.7V					100	μA
I _{IL}	Low-level input current	V _{IL} = 0.4V					-100	μA
I _{OS}	Short-circuit output current	V _O = -7V					-250	mA
		V _O = V _{CC}					250	
		V _O = 12V					250	
		V _O = 0V					150	
I _{CC}	Supply current (total package)	No load	Outputs enabled			35	50	mA
			Outputs disabled			20	50	

(1) All typical values are at V_{CC} = 5V and T_A = 25°C.

(2) The minimum V_{OD2} with a 100Ω load is either 1/2 V_{OD1} or 2V, whichever is greater.

(3) The algebraic convention, where the less positive (more negative) limit is designated as minimum, is used in this data sheet for common-mode output and threshold voltage levels only.

(4) See TIA/EIA-485-A Figure 6-3.5, test termination measurement 2.

(5) Δ|V_{OD}| and Δ|V_{OC}| are the changes in magnitude of V_{OD} and V_{OC}, respectively, that occur when the input is changed from a high level to a low level.

5.4.2 Switching Characteristics

at V_{CC} = 5V, T_A = 25°C (unless otherwise noted)

PARAMETER		TEST CONDITIONS			MIN	TYP	MAX	UNIT
t _{PLH}	Propagation delay time, high- to low-level output	R _L = 60Ω, C _{L1} = C _{L2} = 100pF, See Figure 6-3			9	15	22	ns
t _{PHL}	Propagation delay time, low- to high-level output	R _L = 60Ω, C _{L1} = C _{L2} = 100pF, See Figure 6-3			9	15	22	ns
t _{sk}	Output-to-output skew	R _L = 60Ω, C _{L1} = C _{L2} = 100pF, See Figure 6-3			0	2	8	ns
t _{PZH}	Output enable time to high level	C _L = 100pF,	See Figure 6-4		30	35	50	ns
t _{PZL}	Output enable time to low level	C _L = 100pF,	See Figure 6-5		5	15	25	ns
t _{PHZ}	Output disable time from high level	C _L = 15pF,	See Figure 6-4		7	15	30	ns
t _{PLZ}	Output disable time from low level	C _L = 15pF,	See Figure 6-5		7	15	30	ns

5.5 Receiver Section

5.5.1 Electrical Characteristics

over recommended ranges of common-mode input voltage, supply voltage, and operating free-air temperature (unless otherwise noted)

PARAMETER		TEST CONDITIONS		MIN	TYP ⁽¹⁾	MAX	UNIT
V _{IT+}	Positive-going input threshold voltage		V _O = 2.7V, I _O = -0.4mA			0.2	V
V _{IT-}	Negative-going input threshold voltage		V _O = 0.5V, I _O = 8mA	-0.2 ⁽²⁾			V
V _{hys}	Input hysteresis voltage (V _{IT+} - V _{IT-})				50		mV
V _{IK}	Enable input clamp voltage	SN75ALS1177	I _I = -18mA			-1.5	V
V _{OH}	High-level output voltage		V _{ID} = 200mV, I _{OH} = -400μA, See Figure 6-2	2.7			V
V _{OL}	Low-level output voltage		V _{ID} = 200mV, I _{OL} = 8mA, See Figure 6-2			0.45	V
I _{OZ}	High-impedance-state output current	SN75ALS1177	V _O = 0.4V to 2.4V			±20	μA
I _I	Line input current (see Note 6)		Other input at 0V	V _I = 12V		1	mA
				V _I = -7V		-0.8	
I _{IH}	High-level input current, \overline{RE}	SN75ALS1177	V _{IH} = 2.7V			20	μA
I _{IL}	Low-level input current, \overline{RE}	SN75ALS1177	V _{IL} = 0.4V			-100	μA
r _i	Input resistance			12			kΩ
I _{OS}	Short-circuit output current		V _O = 0V, See Note 7	-15		-85	mA
I _{CC}	Supply current (total package)		No load, outputs enabled		35	50	mA

- (1) All typical values are at V_{CC} = 5V and T_A = 25°C.
- (2) The algebraic convention, where the less positive (more negative) limit is designated as minimum, is used in this data sheet for common-mode output and threshold voltage levels only.
- (3) Refer to TIA/EIA-422-B, TIA/EIA-423-A, and TIA/EIA-485-A for exact conditions.
- (4) Not more than one output should be shorted at a time.

5.5.2 Switching Characteristics

at V_{CC} = 5V, T_A = 25°C (unless otherwise noted)

PARAMETER		TEST CONDITIONS		MIN	TYP	MAX	UNIT
t _{PLH}	Propagation delay time, low- to high-level output		C _L = 15pF, See Figure 6-6	15	25	37	ns
t _{PHL}	Propagation delay time, high- to low-level output		C _L = 15pF, See Figure 6-6	15	25	37	ns
t _{PZH}	Output enable time to high level	SN75ALS1177	C _L = 100pF, See Figure 6-7	10	20	30	ns
t _{PZL}	Output enable time to low level	SN75ALS1177	C _L = 100pF, See Figure 6-7	10	20	30	ns
t _{PHZ}	Output disable time from high level	SN75ALS1177	C _L = 15pF, See Figure 6-7	3.5	12	16	ns
t _{PLZ}	Output disable time from low level	SN75ALS1177	C _L = 15pF, See Figure 6-7	5	12	16	ns

6 Parameter Measurement Information

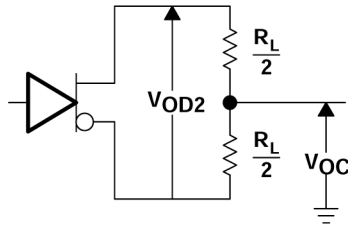

Figure 6-1. Driver Test Circuit, V_{OD} and V_{OC}

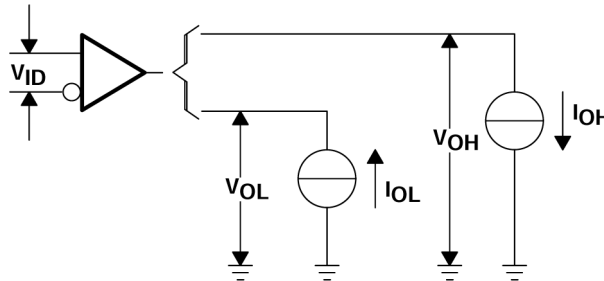
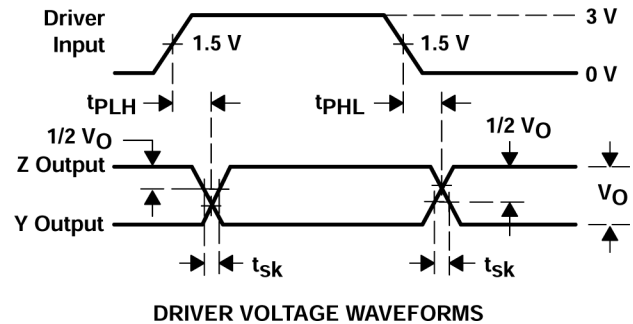
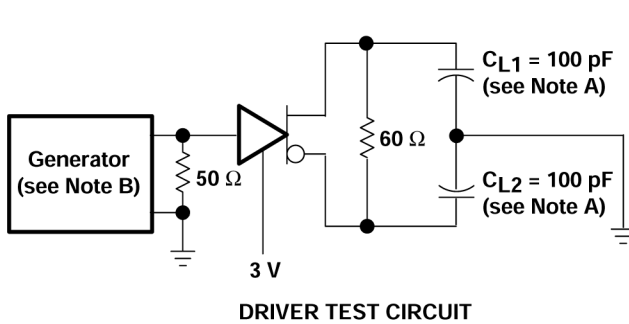
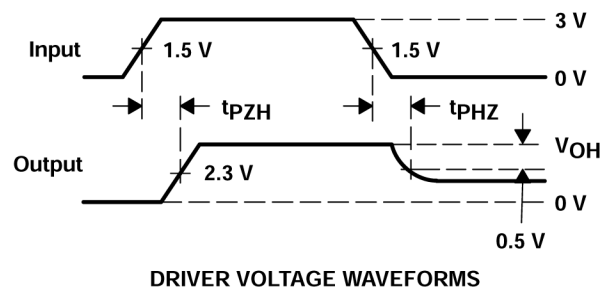
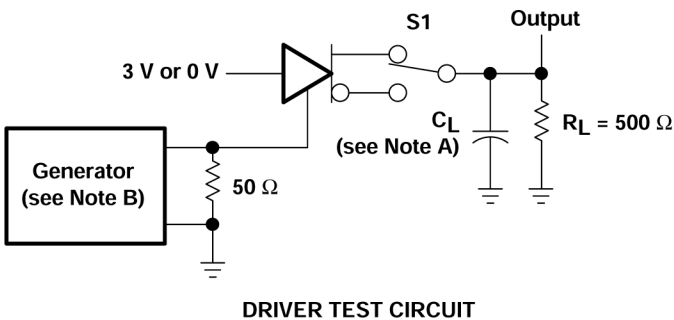

Figure 6-2. Receiver Test Circuit, V_{OH} and V_{OL}



- A. C_L includes probe and jig capacitance.
- B. The pulse generator has the following characteristics: $PRR \leq 1\text{MHz}$, 50% duty cycle, $t_r \leq 10\text{ns}$, $t_f \leq 10\text{ns}$.

Figure 6-3. Driver Propagation Delay Times



- A. C_L includes probe and jig capacitance.
- B. The pulse generator has the following characteristics: $PRR \leq 1\text{MHz}$, 50% duty cycle, $t_r \leq 10\text{ns}$, $t_f \leq 10\text{ns}$.

Figure 6-4. Driver Enable and Disable Times

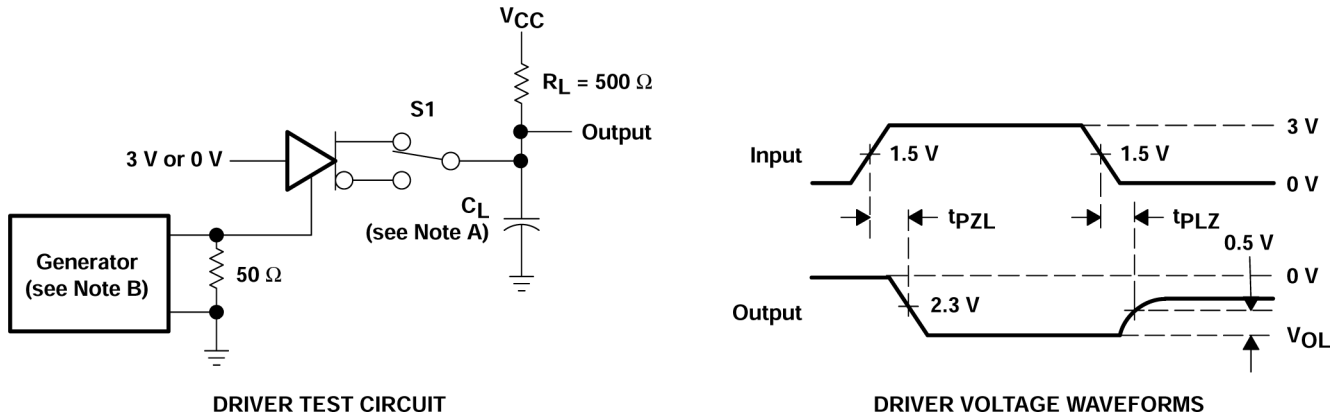

- A. C_L includes probe and jig capacitance.
- B. The pulse generator has the following characteristics: $PRR \leq 1\text{MHz}$, 50% duty cycle, $t_r \leq 10\text{ns}$, $t_f \leq 10\text{ns}$.

Figure 6-5. Driver Enable and Disable Times

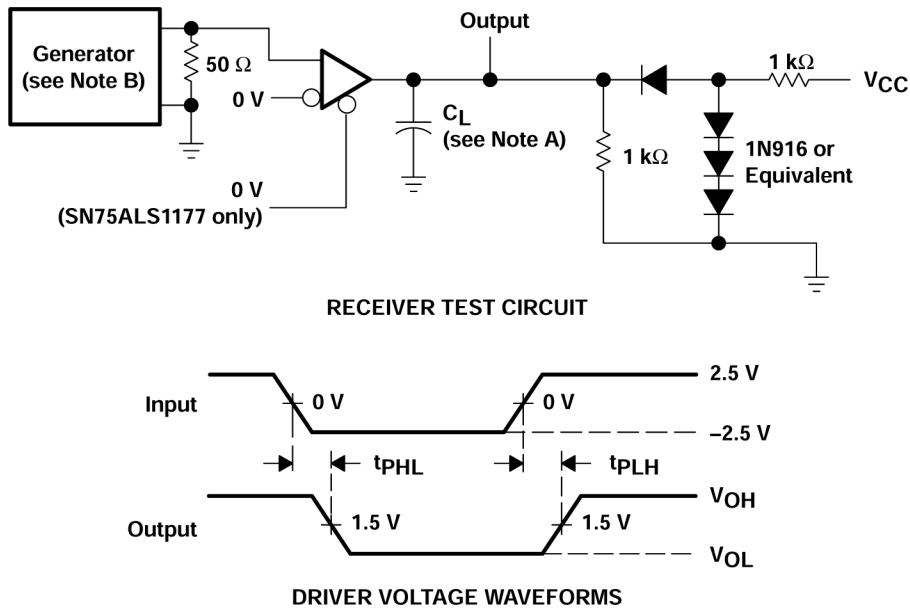

- A. C_L includes probe and jig capacitance.
- B. The pulse generator has the following characteristics: $PRR \leq 1\text{MHz}$, 50% duty cycle, $t_r \leq 10\text{ns}$, $t_f \leq 10\text{ns}$.

Figure 6-6. Receiver Propagation Delay Times

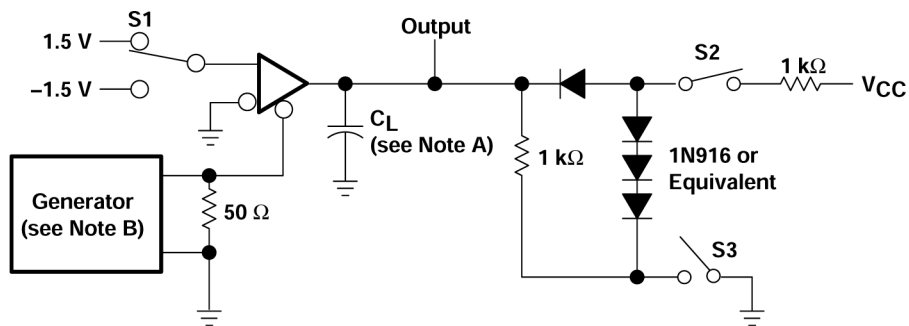

RECEIVER TEST CIRCUIT

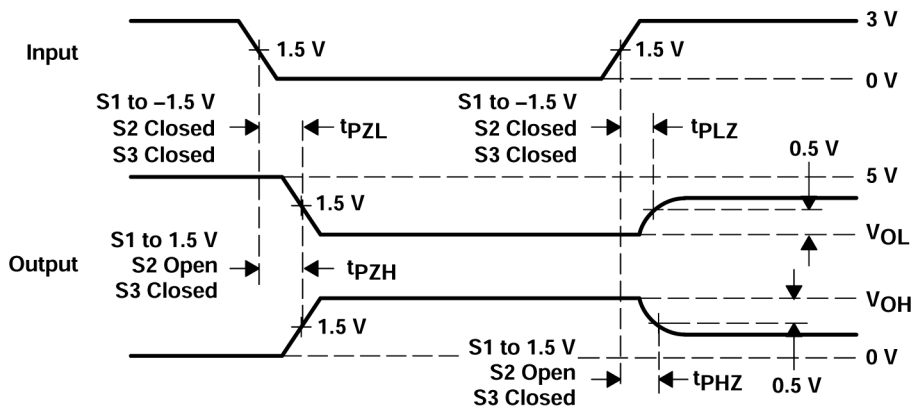

RECEIVER VOLTAGE WAVEFORMS

- A. C_L includes probe and jig capacitance.
- B. The pulse generator has the following characteristics: $PRR \leq 1\text{MHz}$, 50% duty cycle, $t_r \leq 10\text{ns}$, $t_f \leq 10\text{ns}$.

Figure 6-7. Receiver Output Enable and Disable Times

7 Detailed Description

7.1 Device Functional Modes

Table 7-1. SN75ALS1177, SN75ALS1178 Functional Table (Each Driver)

INPUT D	ENABLE DE	OUTPUTS ⁽¹⁾	
		Y	Z
H	H	H	L
L	H	L	H
X	L	Z	Z

Table 7-2. SN75ALS1177 Functional Table (Each Receiver)

DIFFERENTIAL A-B	ENABLE \overline{RE} ⁽¹⁾	OUTPUT Y ⁽¹⁾
$V_{ID} \geq 0.2V$	L	H
$-0.2V < V_{ID} < 0.2V$	L	?
$V_{ID} \leq -0.2V$	L	L
X	H	Z
Open	L	H

Table 7-3. SN75ALS1178 Functional Table (Each Receiver)

DIFFERENTIAL A-B	OUTPUT Y ⁽¹⁾
$V_{ID} \geq 0.2V$	H
$-0.2V < V_{ID} < 0.2V$?
$V_{ID} \leq -0.2V$	L
Open	H

(1) H = High level, L = Low level, ? = Indeterminate, X = Irrelevant, Z = High impedance (off)

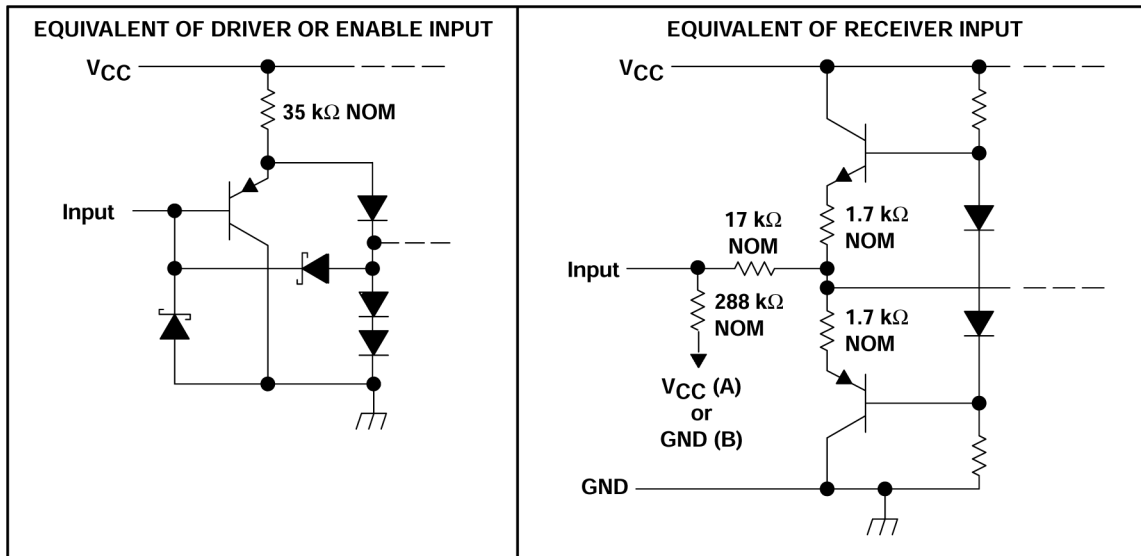

Figure 7-1. Equivalent Schematics

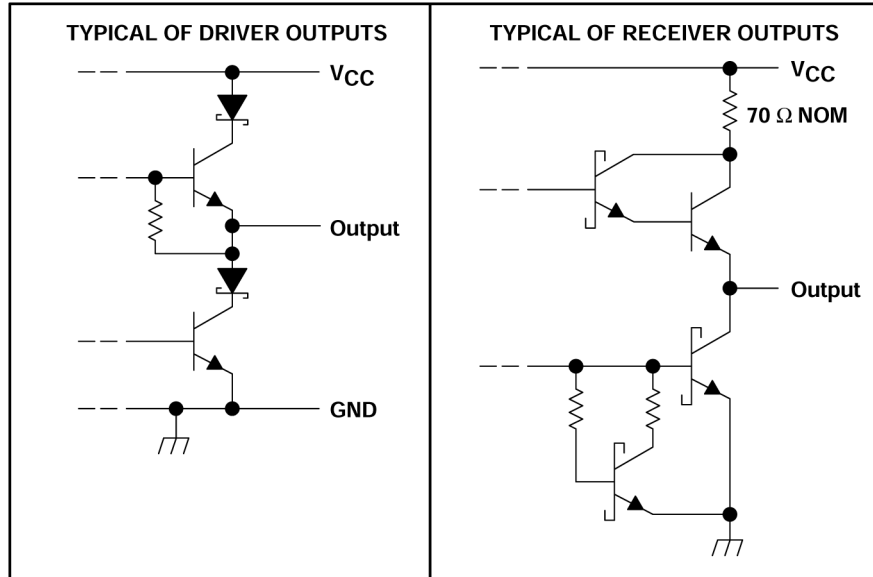

Figure 7-2. Schematics of Outputs

8 Device and Documentation Support

TI offers an extensive line of development tools. Tools and software to evaluate the performance of the device, generate code, and develop solutions are listed below.

8.1 Documentation Support

8.2 Receiving Notification of Documentation Updates

To receive notification of documentation updates, navigate to the device product folder on [ti.com](https://www.ti.com). Click on *Subscribe to updates* to register and receive a weekly digest of any product information that has changed. For change details, review the revision history included in any revised document.

8.3 Support Resources

[E2E™ support forums](#) are an engineer's go-to source for fast, verified answers and design help — straight from the experts. Search existing answers or ask your own question to get the quick design help you need.

Linked content is provided "AS IS" by the respective contributors. They do not constitute TI specifications and do not necessarily reflect TI's views; see TI's [Terms of Use](#).

8.4 Trademarks

E2E™ is a trademark of Texas Instruments.

All trademarks are the property of their respective owners.

8.5 Electrostatic Discharge Caution



This integrated circuit can be damaged by ESD. Texas Instruments recommends that all integrated circuits be handled with appropriate precautions. Failure to observe proper handling and installation procedures can cause damage.

ESD damage can range from subtle performance degradation to complete device failure. Precision integrated circuits may be more susceptible to damage because very small parametric changes could cause the device not to meet its published specifications.

8.6 Glossary

[TI Glossary](#) This glossary lists and explains terms, acronyms, and definitions.

9 Revision History

Changes from Revision B (February 2001) to Revision C (February 2024)	Page
• Changed the numbering format for tables, figures, and cross-references throughout the document.....	1

10 Mechanical, Packaging, and Orderable Information

The following pages include mechanical, packaging, and orderable information. This information is the most current data available for the designated devices. This data is subject to change without notice and revision of this document. For browser-based versions of this data sheet, refer to the left-hand navigation.

PACKAGING INFORMATION

Orderable Device	Status (1)	Package Type	Package Drawing	Pins	Package Qty	Eco Plan (2)	Lead finish/ Ball material (6)	MSL Peak Temp (3)	Op Temp (°C)	Device Marking (4/5)	Samples
SN75ALS1177N	ACTIVE	PDIP	N	16	25	RoHS & Green	NIPDAU	N / A for Pkg Type	0 to 70	SN75ALS1177N	Samples
SN75ALS1177NSR	ACTIVE	SO	NS	16	2000	RoHS & Green	NIPDAU	Level-1-260C-UNLIM	0 to 70	75ALS1177	Samples
SN75ALS1178N	ACTIVE	PDIP	N	16	25	RoHS & Green	NIPDAU	N / A for Pkg Type	0 to 70	SN75ALS1178N	Samples
SN75ALS1178NSR	ACTIVE	SO	NS	16	2000	RoHS & Green	NIPDAU	Level-1-260C-UNLIM	0 to 70	75ALS1178	Samples

(1) The marketing status values are defined as follows:

ACTIVE: Product device recommended for new designs.

LIFEBUY: TI has announced that the device will be discontinued, and a lifetime-buy period is in effect.

NRND: Not recommended for new designs. Device is in production to support existing customers, but TI does not recommend using this part in a new design.

PREVIEW: Device has been announced but is not in production. Samples may or may not be available.

OBSELETE: TI has discontinued the production of the device.

(2) **RoHS:** TI defines "RoHS" to mean semiconductor products that are compliant with the current EU RoHS requirements for all 10 RoHS substances, including the requirement that RoHS substance do not exceed 0.1% by weight in homogeneous materials. Where designed to be soldered at high temperatures, "RoHS" products are suitable for use in specified lead-free processes. TI may reference these types of products as "Pb-Free".

RoHS Exempt: TI defines "RoHS Exempt" to mean products that contain lead but are compliant with EU RoHS pursuant to a specific EU RoHS exemption.

Green: TI defines "Green" to mean the content of Chlorine (Cl) and Bromine (Br) based flame retardants meet JS709B low halogen requirements of <=1000ppm threshold. Antimony trioxide based flame retardants must also meet the <=1000ppm threshold requirement.

(3) MSL, Peak Temp. - The Moisture Sensitivity Level rating according to the JEDEC industry standard classifications, and peak solder temperature.

(4) There may be additional marking, which relates to the logo, the lot trace code information, or the environmental category on the device.

(5) Multiple Device Markings will be inside parentheses. Only one Device Marking contained in parentheses and separated by a "-" will appear on a device. If a line is indented then it is a continuation of the previous line and the two combined represent the entire Device Marking for that device.

(6) Lead finish/Ball material - Orderable Devices may have multiple material finish options. Finish options are separated by a vertical ruled line. Lead finish/Ball material values may wrap to two lines if the finish value exceeds the maximum column width.

Important Information and Disclaimer:The information provided on this page represents TI's knowledge and belief as of the date that it is provided. TI bases its knowledge and belief on information provided by third parties, and makes no representation or warranty as to the accuracy of such information. Efforts are underway to better integrate information from third parties. TI has taken and

continues to take reasonable steps to provide representative and accurate information but may not have conducted destructive testing or chemical analysis on incoming materials and chemicals. TI and TI suppliers consider certain information to be proprietary, and thus CAS numbers and other limited information may not be available for release.

In no event shall TI's liability arising out of such information exceed the total purchase price of the TI part(s) at issue in this document sold by TI to Customer on an annual basis.

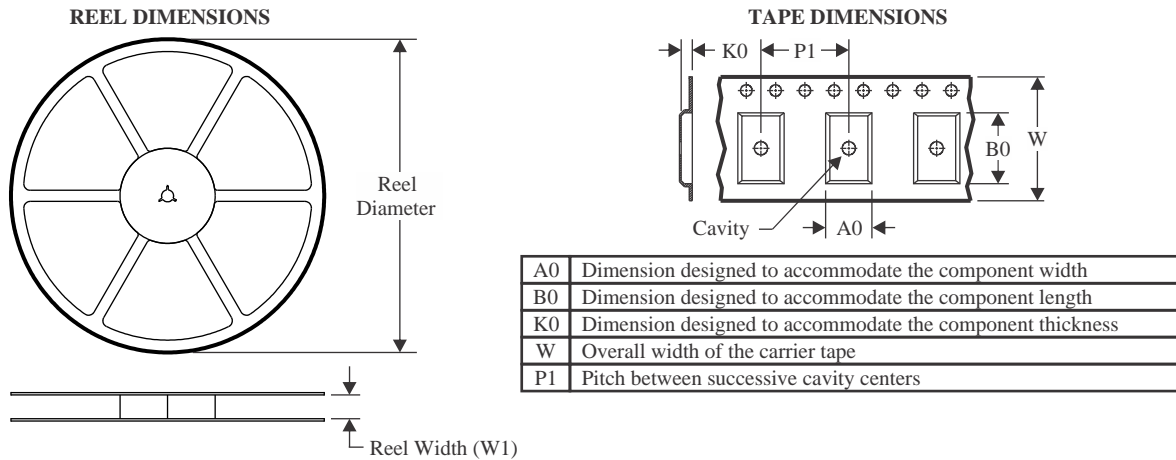
TAPE AND REEL INFORMATION

QUADRANT ASSIGNMENTS FOR PIN 1 ORIENTATION IN TAPE

*All dimensions are nominal

Device	Package Type	Package Drawing	Pins	SPQ	Reel Diameter (mm)	Reel Width W1 (mm)	A0 (mm)	B0 (mm)	K0 (mm)	P1 (mm)	W (mm)	Pin1 Quadrant
SN75ALS1177NSR	SO	NS	16	2000	330.0	16.4	8.2	10.5	2.5	12.0	16.0	Q1
SN75ALS1178NSR	SO	NS	16	2000	330.0	16.4	8.2	10.5	2.5	12.0	16.0	Q1

TAPE AND REEL BOX DIMENSIONS



*All dimensions are nominal

Device	Package Type	Package Drawing	Pins	SPQ	Length (mm)	Width (mm)	Height (mm)
SN75ALS1177NSR	SO	NS	16	2000	356.0	356.0	35.0
SN75ALS1178NSR	SO	NS	16	2000	356.0	356.0	35.0

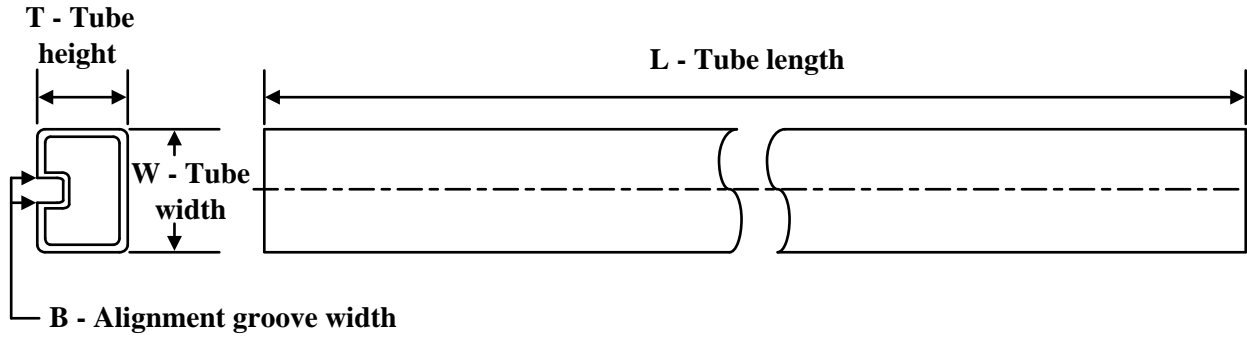
TUBE

*All dimensions are nominal

Device	Package Name	Package Type	Pins	SPQ	L (mm)	W (mm)	T (μm)	B (mm)
SN75ALS1177N	N	PDIP	16	25	506	13.97	11230	4.32
SN75ALS1178N	N	PDIP	16	25	506	13.97	11230	4.32

N (R-PDIP-T**)

PLASTIC DUAL-IN-LINE PACKAGE

16 PINS SHOWN



- NOTES:
- A. All linear dimensions are in inches (millimeters).
 - B. This drawing is subject to change without notice.
 - Falls within JEDEC MS-001, except 18 and 20 pin minimum body length (Dim A).
 - The 20 pin end lead shoulder width is a vendor option, either half or full width.



PACKAGE OUTLINE

NS0016A

SOP - 2.00 mm max height

SOP



NOTES:

1. All linear dimensions are in millimeters. Dimensions in parenthesis are for reference only. Dimensioning and tolerancing per ASME Y14.5M.
2. This drawing is subject to change without notice.
3. This dimension does not include mold flash, protrusions, or gate burrs. Mold flash, protrusions, or gate burrs shall not exceed 0.15 mm, per side.
4. This dimension does not include interlead flash. Interlead flash shall not exceed 0.25 mm, per side.

EXAMPLE BOARD LAYOUT

NS0016A

SOP - 2.00 mm max height

SOP



4220735/A 12/2021

NOTES: (continued)

5. Publication IPC-7351 may have alternate designs.

6. Solder mask tolerances between and around signal pads can vary based on board fabrication site.

EXAMPLE STENCIL DESIGN

NS0016A

SOP - 2.00 mm max height

SOP



SOLDER PASTE EXAMPLE
BASED ON 0.125 mm THICK STENCIL
SCALE:7X

4220735/A 12/2021

NOTES: (continued)

7. Laser cutting apertures with trapezoidal walls and rounded corners may offer better paste release. IPC-7525 may have alternate design recommendations.
8. Board assembly site may have different recommendations for stencil design.

MECHANICAL DATA

NS (R-PDSO-G**)

PLASTIC SMALL-OUTLINE PACKAGE

14-PINS SHOWN



- NOTES:
- A. All linear dimensions are in millimeters.
 - B. This drawing is subject to change without notice.
 - C. Body dimensions do not include mold flash or protrusion, not to exceed 0,15.

IMPORTANT NOTICE AND DISCLAIMER

TI PROVIDES TECHNICAL AND RELIABILITY DATA (INCLUDING DATA SHEETS), DESIGN RESOURCES (INCLUDING REFERENCE DESIGNS), APPLICATION OR OTHER DESIGN ADVICE, WEB TOOLS, SAFETY INFORMATION, AND OTHER RESOURCES "AS IS" AND WITH ALL FAULTS, AND DISCLAIMS ALL WARRANTIES, EXPRESS AND IMPLIED, INCLUDING WITHOUT LIMITATION ANY IMPLIED WARRANTIES OF MERCHANTABILITY, FITNESS FOR A PARTICULAR PURPOSE OR NON-INFRINGEMENT OF THIRD PARTY INTELLECTUAL PROPERTY RIGHTS.

These resources are intended for skilled developers designing with TI products. You are solely responsible for (1) selecting the appropriate TI products for your application, (2) designing, validating and testing your application, and (3) ensuring your application meets applicable standards, and any other safety, security, regulatory or other requirements.

These resources are subject to change without notice. TI grants you permission to use these resources only for development of an application that uses the TI products described in the resource. Other reproduction and display of these resources is prohibited. No license is granted to any other TI intellectual property right or to any third party intellectual property right. TI disclaims responsibility for, and you will fully indemnify TI and its representatives against, any claims, damages, costs, losses, and liabilities arising out of your use of these resources.

TI's products are provided subject to [TI's Terms of Sale](#) or other applicable terms available either on [ti.com](https://www.ti.com) or provided in conjunction with such TI products. TI's provision of these resources does not expand or otherwise alter TI's applicable warranties or warranty disclaimers for TI products.

TI objects to and rejects any additional or different terms you may have proposed.

Mailing Address: Texas Instruments, Post Office Box 655303, Dallas, Texas 75265
Copyright © 2024, Texas Instruments Incorporated

Looking for pricing, stock, or lifecycle information?

Click below to explore more details on WIN SOURCE:

 [View SN75ALS1177NSR on WIN SOURCE](#)

 [Texas Instruments](#) Information

Optimize Your Supply Chain with WIN SOURCE Solutions

-  Global Sourcing Solution
-  Obsolete Management
-  Cost Control Management
-  Shortage Management
-  Alternative Solution
-  Excess Inventory Management