



**THE DATASHEET OF
SN75182N**



SN55182, SN75182 DUAL DIFFERENTIAL LINE RECEIVERS

SLLS092D – OCTOBER 1972 – REVISED APRIL 1998

- Single 5-V Supply
- Differential Line Operation
- Dual Channels
- TTL Compatibility
- ± 15 -V Common-Mode Input Voltage Range
- ± 15 -V Differential Input Voltage Range
- Individual Channel Strobes
- Built-In Optional Line-Termination Resistor
- Individual Frequency Response Controls
- Designed for Use With Dual Differential Drivers SN55183 and SN75183
- Designed to Be Interchangeable With National Semiconductor DS7820A and DS8820A

description

The SN55182 and SN75182 dual differential line receivers are designed to sense small differential signals in the presence of large common-mode noise. These devices give TTL-compatible output signals as a function of the polarity of the differential input voltage. The frequency response of each channel can be easily controlled by a single external capacitor to provide immunity to differential noise spikes. The output goes to a high level when the inputs are open circuited. A strobe input (STRB) is provided that, when in the low level, disables the receiver and forces the output to a high level.

The receiver is of monolithic single-chip construction, and both halves of the dual circuits use common power-supply and ground terminals.

The SN55182 is characterized for operation over the full military temperature range of -55°C to 125°C . The SN75182 is characterized for operation from 0°C to 70°C .

SN55182 . . . J OR W PACKAGE
SN75182 . . . N PACKAGE
(TOP VIEW)

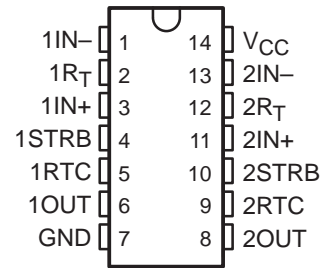

SN55182 . . . FK PACKAGE
(TOP VIEW)

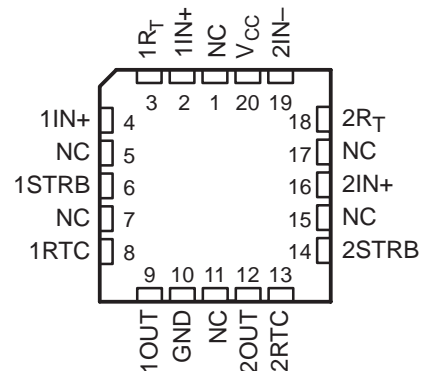

NC – No internal connection

**THE SN55182 IS NOT RECOMMENDED
FOR NEW DESIGNS**

FUNCTION TABLE

INPUTS		OUTPUT OUT
STRB	V _{ID}	
L	X	H
H	H	H
H	L	L

H = $V_I \geq V_{IH}$ min or V_{ID} more positive than V_{TH} max
L = $V_I \leq V_{IL}$ max or V_{ID} more negative than V_{TL} max
X = irrelevant



Please be aware that an important notice concerning availability, standard warranty, and use in critical applications of Texas Instruments semiconductor products and disclaimers thereto appears at the end of this data sheet.

PRODUCTION DATA information is current as of publication date. Products conform to specifications per the terms of Texas Instruments standard warranty. Production processing does not necessarily include testing of all parameters.

 **TEXAS
INSTRUMENTS**

POST OFFICE BOX 655303 • DALLAS, TEXAS 75265

Copyright © 1998, Texas Instruments Incorporated

SN55182, SN75182 DUAL DIFFERENTIAL LINE RECEIVERS

SLLS092D – OCTOBER 1972 – REVISED APRIL 1998

logic symbol†

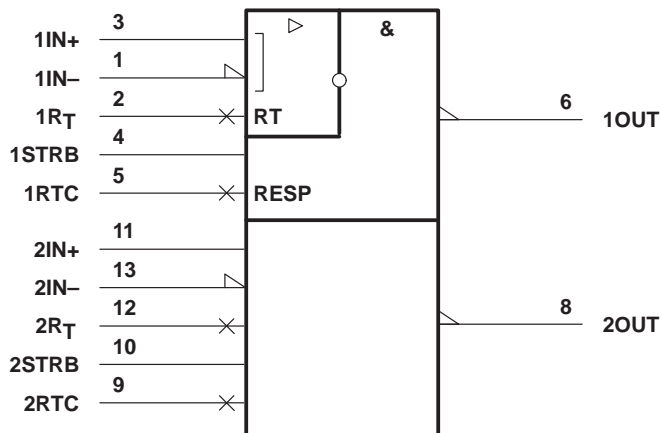

† This symbol is in accordance with ANSI/IEEE Std 91-1984 and IEC Publication 617-12. Pin numbers shown are for the J, N, and W packages.

logic diagram (positive logic)

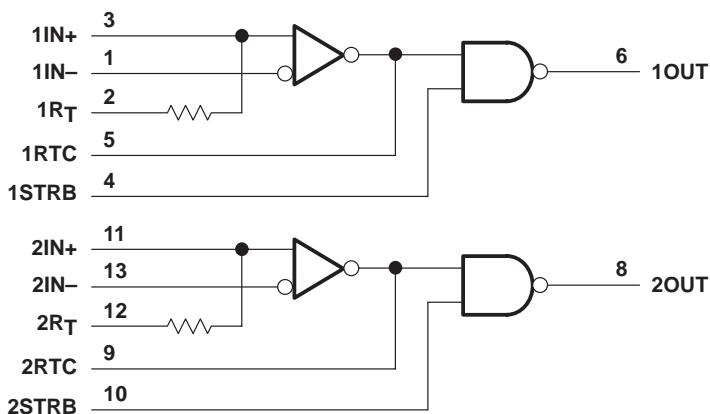

Pin numbers shown are for the J, N, and W packages.

SN55182, SN75182 DUAL DIFFERENTIAL LINE RECEIVERS

SLLS092D – OCTOBER 1972 – REVISED APRIL 1998

schematic (each receiver)

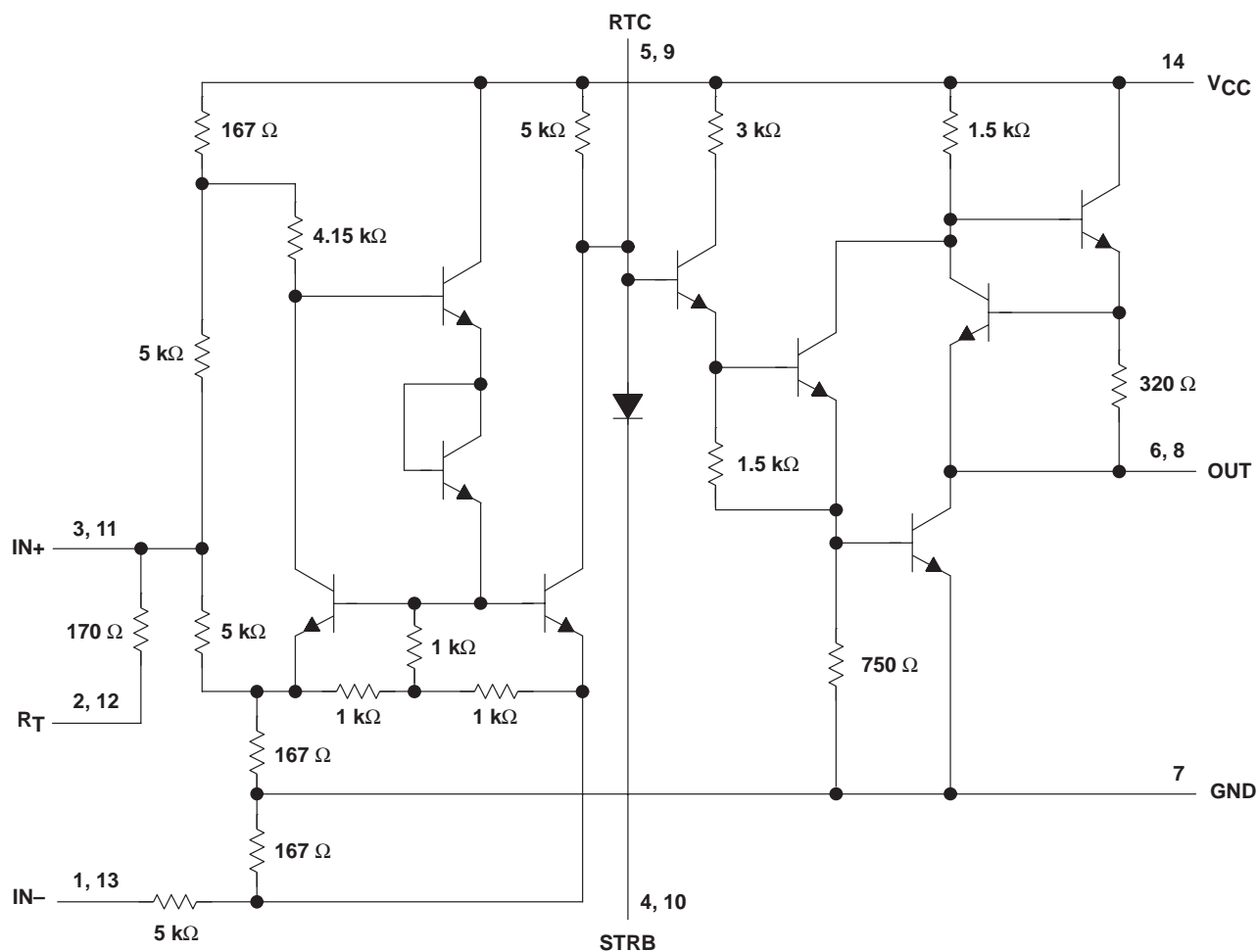

Resistor values shown are nominal.
Pin numbers shown are for the J, N, and W packages.

SN55182, SN75182 DUAL DIFFERENTIAL LINE RECEIVERS

SLLS092D – OCTOBER 1972 – REVISED APRIL 1998

absolute maximum ratings over operating free-air temperature range (unless otherwise noted)†

Supply voltage, V_{CC} (see Note 1)	8 V
Common-mode input voltage, V_{IC}	± 20 V
Differential input voltage, V_{ID} (see Note 2)	± 20 V
Strobe input voltage, $V_{I(STRB)}$	8 V
Output sink current	50 mA
Continuous total power dissipation	See Dissipation Rating Table
Storage temperature range, T_{stg}	-65°C to 150°C
Lead temperature 1,6 mm (1/16 inch) from case for 10 seconds: N package	260°C
Lead temperature 1,6 mm (1/16 inch) from case for 60 seconds: J or W package	300°C
Case temperature for 60 seconds, T_C : FK package	260°C

† Stresses beyond those listed under “absolute maximum ratings” may cause permanent damage to the device. These are stress ratings only, and functional operation of the device at these or any other conditions beyond those indicated under “recommended operating conditions” is not implied. Exposure to absolute-maximum-rated conditions for extended periods may affect device reliability.

- NOTES: 1. All voltage values, except differential voltages, are with respect to network ground terminal.
2. Differential voltage values are at the noninverting terminal with respect to the inverting terminal.

DISSIPATION RATING TABLE

PACKAGE	$T_A \leq 25^{\circ}\text{C}$	DERATING FACTOR	$T_A = 70^{\circ}\text{C}$	$T_A = 125^{\circ}\text{C}$
	POWER RATING	ABOVE $T_A = 25^{\circ}\text{C}$	POWER RATING	POWER RATING
FK‡	1375 mW	11.0 mW/ $^{\circ}\text{C}$	880 mW	275 mW
J‡	1375 mW	11.0 mW/ $^{\circ}\text{C}$	880 mW	275 mW
N	1150 mW	9.2 mW/ $^{\circ}\text{C}$	736 mW	–
W‡	1000 mW	8.0 mW/ $^{\circ}\text{C}$	640 mW	200 mW

‡ In the FK, J, and W packages, SN55182 chips are alloy mounted.

recommended operating conditions

	SN55182			SN75182			UNIT
	MIN	NOM	MAX	MIN	NOM	MAX	
Supply voltage, V_{CC}	4.5	5	5.5	4.5	5	5.5	V
Common-mode input voltage, V_{IC}			± 15			± 15	V
High-level strobe input voltage, $V_{IH(STRB)}$	2.1		5.5	2.1		5.5	V
Low-level strobe input voltage, $V_{IL(STRB)}$	0		0.9	0		0.9	V
High-level output current, I_{OH}			–400			–400	μA
Low-level output current, I_{OL}			16			16	mA
Operating free-air temperature, T_A	–55		125	0		70	$^{\circ}\text{C}$



SN55182, SN75182 DUAL DIFFERENTIAL LINE RECEIVERS

SLLS092D – OCTOBER 1972 – REVISED APRIL 1998

electrical characteristics over recommended ranges of V_{CC} , V_{IC} , and operating free-air temperature (unless otherwise noted)

PARAMETER		TEST CONDITIONS†	MIN	TYP‡	MAX	UNIT		
V_{IT+}	Positive-going input threshold voltage	$V_O = 2.5\text{ V}$, $I_{OH} = -400\ \mu\text{A}$	$V_{IC} = -3\text{ V to }3\text{ V}$		0.5	V		
			$V_{IC} = -15\text{ V to }15\text{ V}$		1			
V_{IT-}	Negative-going input threshold voltage	$V_O = 0.4\text{ V}$, $I_{OL} = 16\text{ mA}$	$V_{IC} = -3\text{ V to }3\text{ V}$		-0.5	V		
			$V_{IC} = -15\text{ V to }15\text{ V}$		-1			
V_{OH}	High-level output voltage	$V_{ID} = 1\text{ V}$, $V(\text{STRB}) = 2.1\text{ V}$, $I_{OH} = -400\ \mu\text{A}$		2.5	4.2	5.5	V	
		$V_{ID} = -1\text{ V}$, $V(\text{STRB}) = 0.4\text{ V}$, $I_{OH} = -400\ \mu\text{A}$		2.5	4.2	5.5		
V_{OL}	Low-level output voltage	$V_{ID} = -1\text{ V}$, $V(\text{STRB}) = 2.1\text{ V}$, $I_{OL} = 16\text{ mA}$		0.25	0.4	V		
I_I	Input current	$V_{IC} = 15\text{ V}$	Inverting input	$V_{IC} = 0$		3	4.2	mA
				$V_{IC} = -15\text{ V}$		0	-0.5	
						-3	-4.2	
			Noninverting input	$V_{IC} = 15\text{ V}$		5	7	
				$V_{IC} = 0$		-1	-1.4	
				$V_{IC} = -15\text{ V}$		-7	-9.8	
$I_{IH}(\text{STRB})$	High-level strobe input current	$V(\text{STRB}) = 5.5\text{ V}$			5	μA		
$I_{IL}(\text{STRB})$	Low-level strobe input current	$V(\text{STRB}) = 0$			-1	-1.4	mA	
r_i	Input resistance		Inverting input		3.6	5	k Ω	
			Noninverting input		1.8	2.5		
	Line-terminating resistance	$T_A = 25^\circ\text{C}$		120	170	250	Ω	
I_{OS}	Short-circuit output current	$V_{CC} = 5.5\text{ V}$, $V_O = 0$		-2.8	-4.5	-6.7	mA	
I_{CC}	Supply current (average per receiver)	$V_{IC} = 15\text{ V}$, $V_{ID} = -1\text{ V}$		4.2	6	mA		
		$V_{IC} = 0$, $V_{ID} = -0.5\text{ V}$		6.8	10.2			
		$V_{IC} = -15\text{ V}$, $V_{ID} = -1\text{ V}$		9.4	14			

† Unless otherwise noted, $V(\text{STRB}) \geq 2.1\text{ V}$ or open.

‡ All typical values are at $V_{CC} = 5\text{ V}$, $V_{IC} = 0$, and $T_A = 25^\circ\text{C}$.

switching characteristics, $V_{CC} = 5\text{ V}$, $T_A = 25^\circ\text{C}$

PARAMETER		TEST CONDITIONS	MIN	TYP	MAX	UNIT
$t_{PLH}(\text{D})$	Propagation delay time, low- to high-level output from differential input	$R_L = 400\ \Omega$, $C_L = 15\text{ pF}$, see Figure 1		18	40	ns
$t_{PHL}(\text{D})$	Propagation delay time, high- to low-level output from differential input	$R_L = 400\ \Omega$, $C_L = 15\text{ pF}$, see Figure 1		31	45	ns
$t_{PLH}(\text{S})$	Propagation delay time, low- to high-level output from STRB input	$R_L = 400\ \Omega$, $C_L = 15\text{ pF}$, see Figure 1		9	30	ns
$t_{PHL}(\text{S})$	Propagation delay time, high- to low-level output from STRB input	$R_L = 400\ \Omega$, $C_L = 15\text{ pF}$, see Figure 1		15	25	ns

SN55182, SN75182 DUAL DIFFERENTIAL LINE RECEIVERS

SLLS092D – OCTOBER 1972 – REVISED APRIL 1998

PARAMETER MEASUREMENT INFORMATION

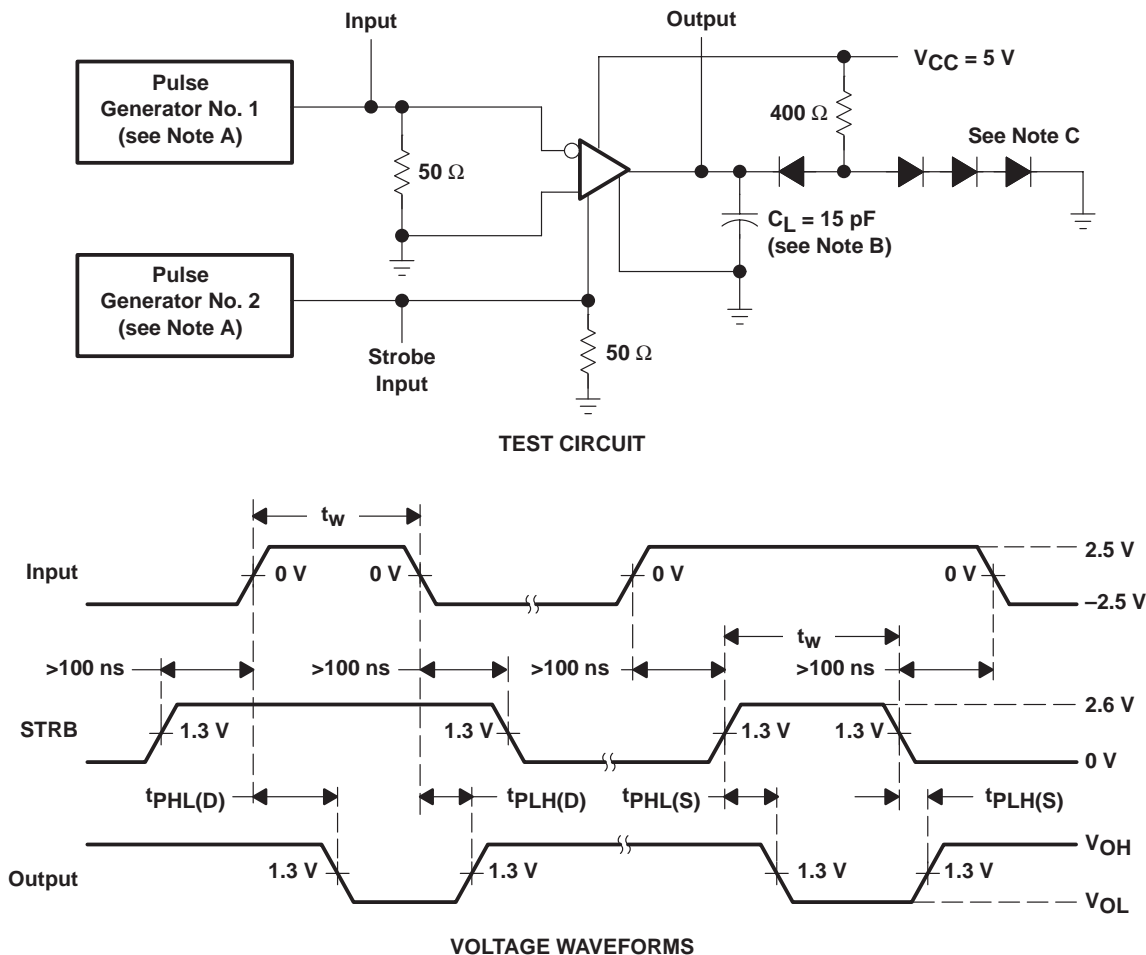

- NOTES: A. The pulse generators have the following characteristics: $Z_O = 50 \Omega$, $t_r \leq 10 \text{ ns}$, $t_f \leq 10 \text{ ns}$, $t_w = 0.5 \pm 0.1 \mu\text{s}$, $\text{PRR} \leq 1 \text{ MHz}$.
 B. C_L includes probe and jig capacitance.
 C. All diodes are 1N3064 or equivalent.

Figure 1. Test Circuit and Voltage Waveforms

TYPICAL CHARACTERISTICS†

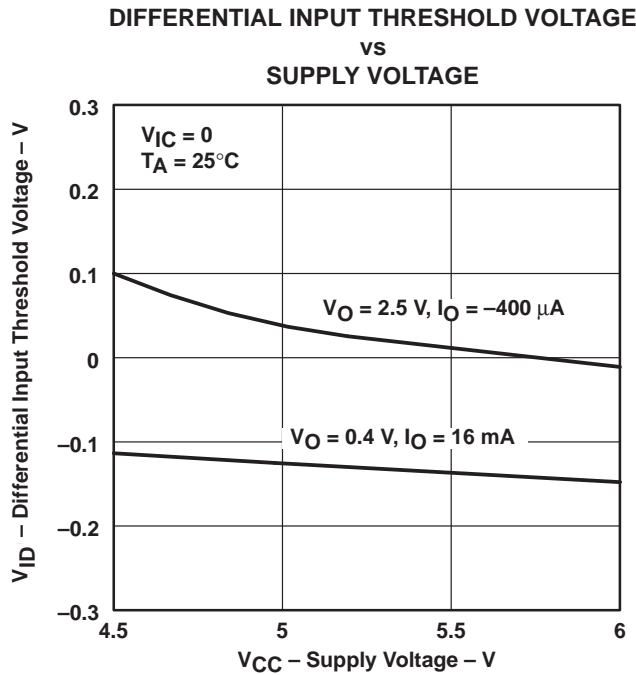

Figure 2

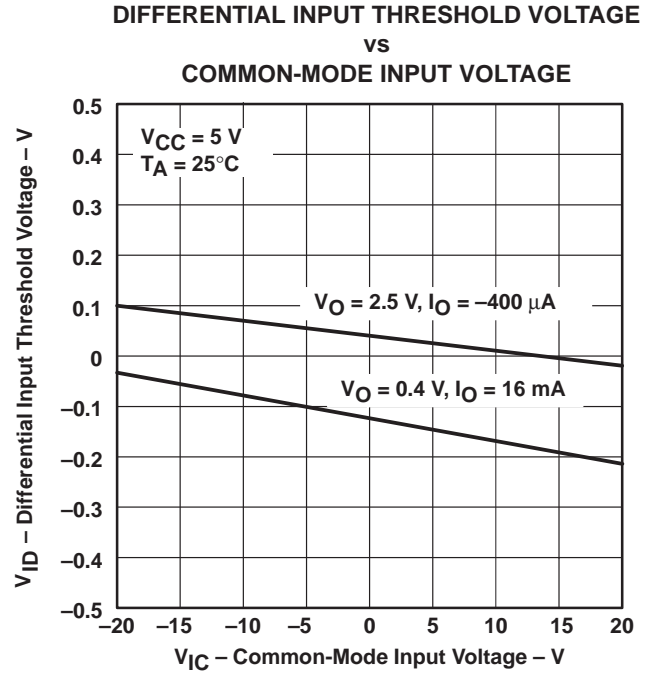

Figure 3

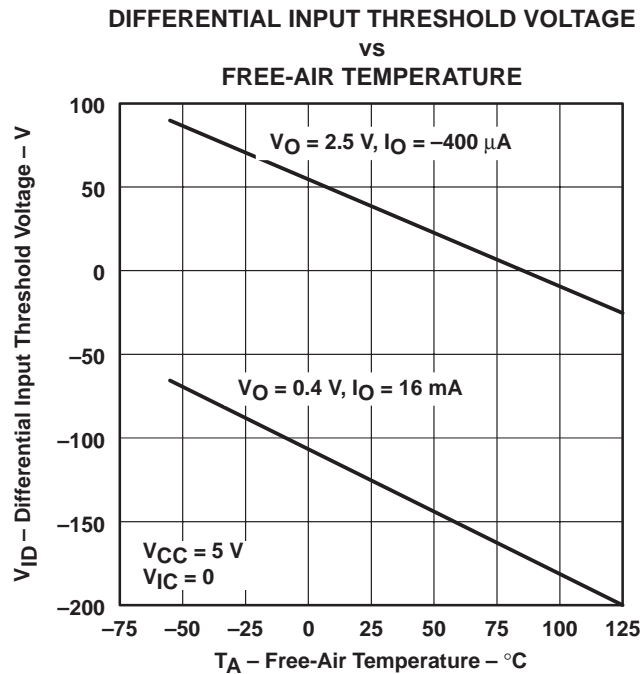

Figure 4

† Operation of the device at these or any other conditions beyond those indicated under "recommended operating conditions" is not implied.

SN55182, SN75182 DUAL DIFFERENTIAL LINE RECEIVERS

SLLS092D – OCTOBER 1972 – REVISED APRIL 1998

TYPICAL CHARACTERISTICS†

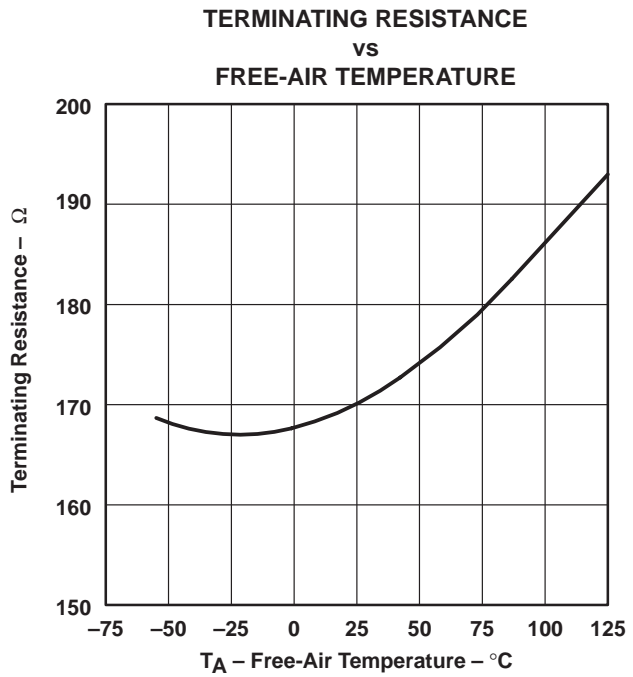
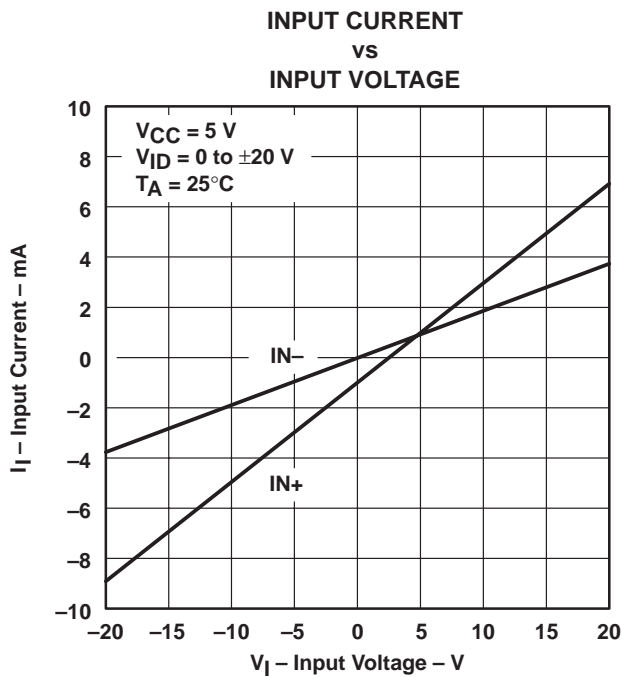
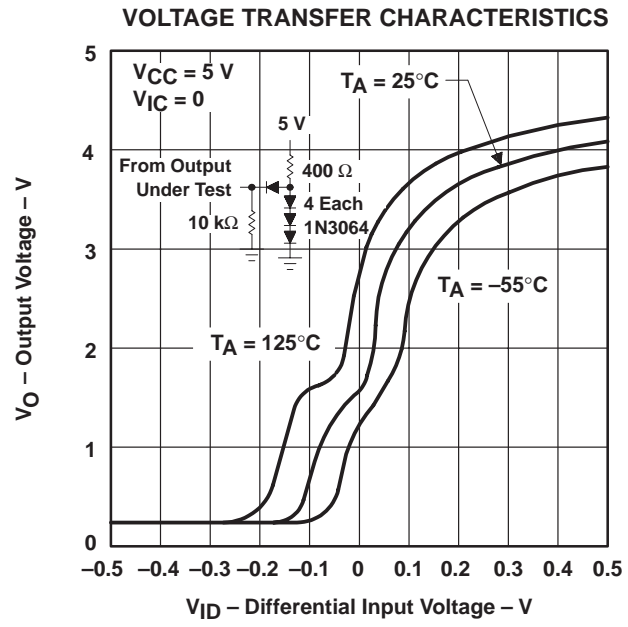
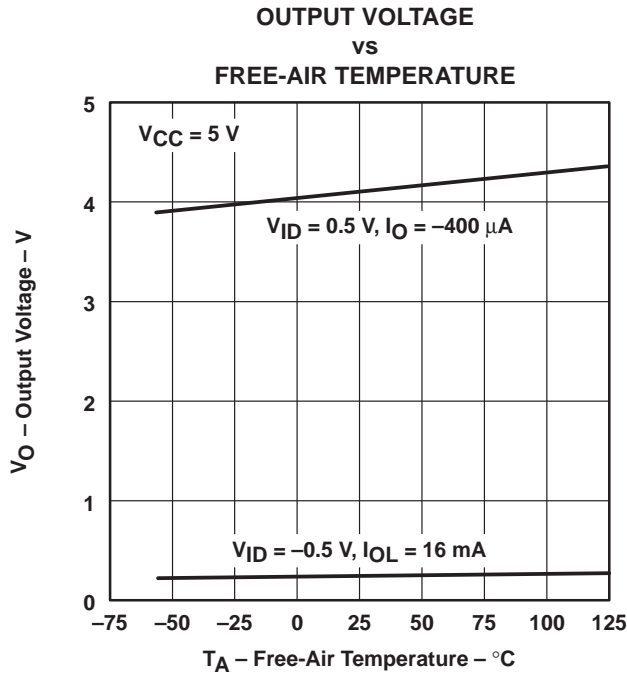

† Operation of the device at these or any other conditions beyond those indicated under "recommended operating conditions" is not implied.

TYPICAL CHARACTERISTICS†

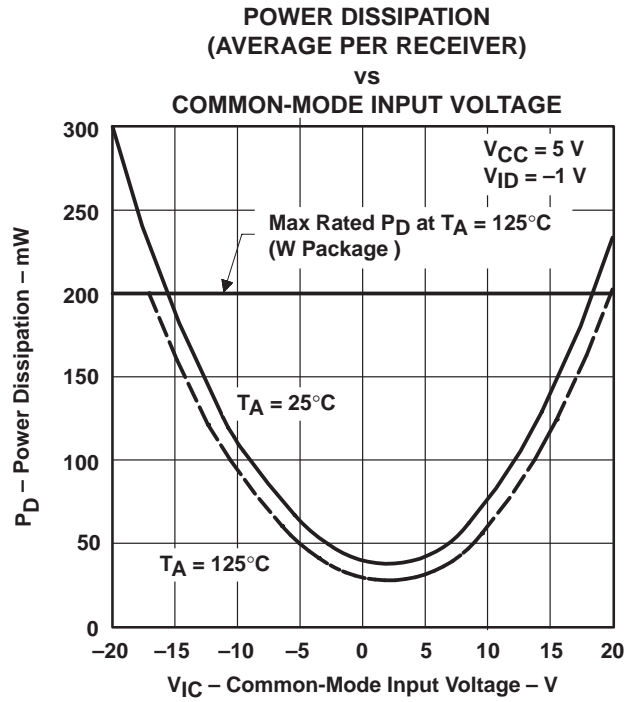
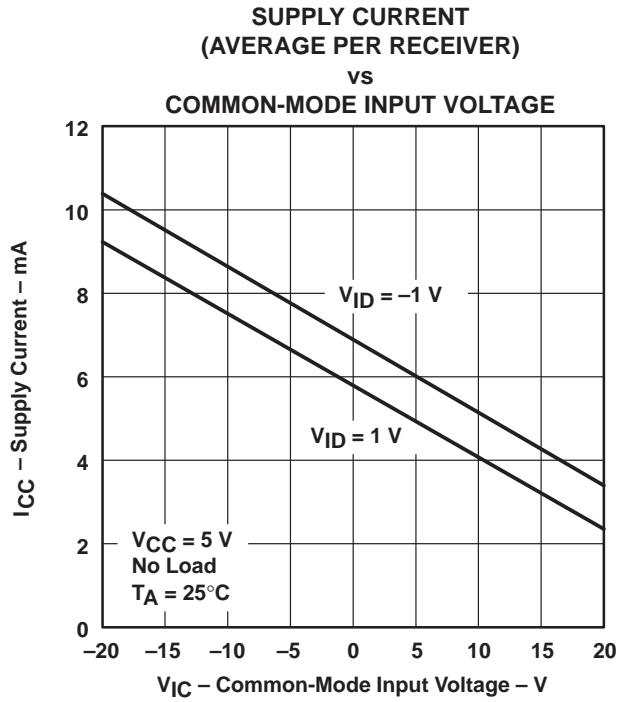

† Operation of the device at these or any other conditions beyond those indicated under "recommended operating conditions" is not implied.

SN55182, SN75182 DUAL DIFFERENTIAL LINE RECEIVERS

SLLS092D – OCTOBER 1972 – REVISED APRIL 1998

TYPICAL CHARACTERISTICS†

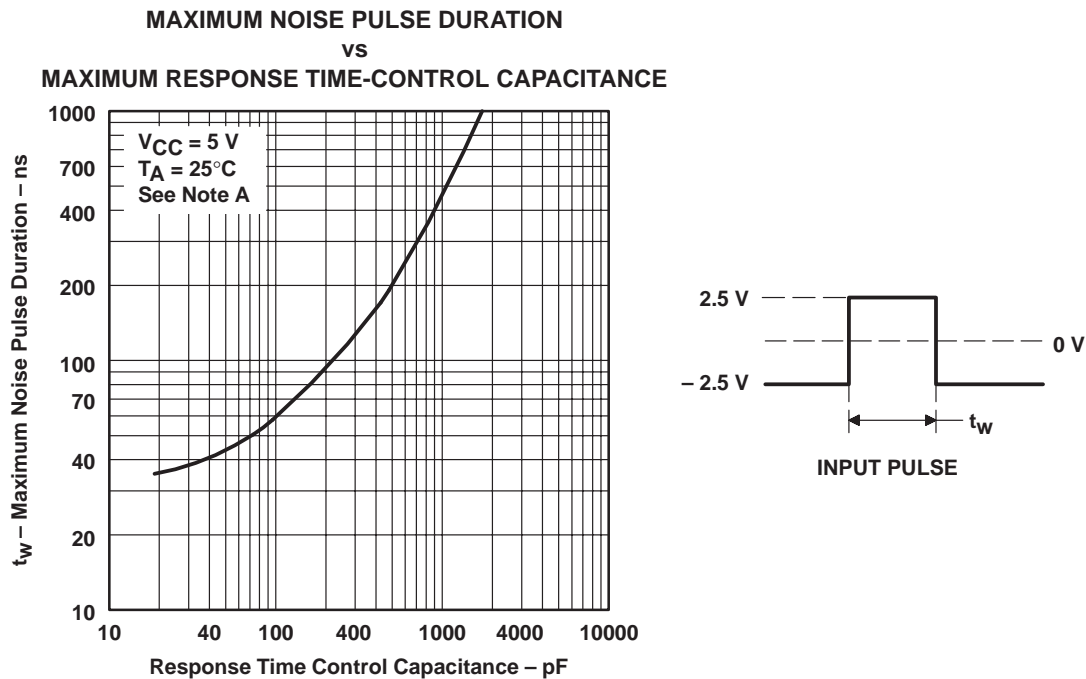

NOTE A: Figure 11 shows the maximum duration of the illustrated pulse that can be applied differently without the output changing from the low to high level.

Figure 11

† Operation of the device at these or any other conditions beyond those indicated under "recommended operating conditions" is not implied.

TYPICAL CHARACTERISTICS†

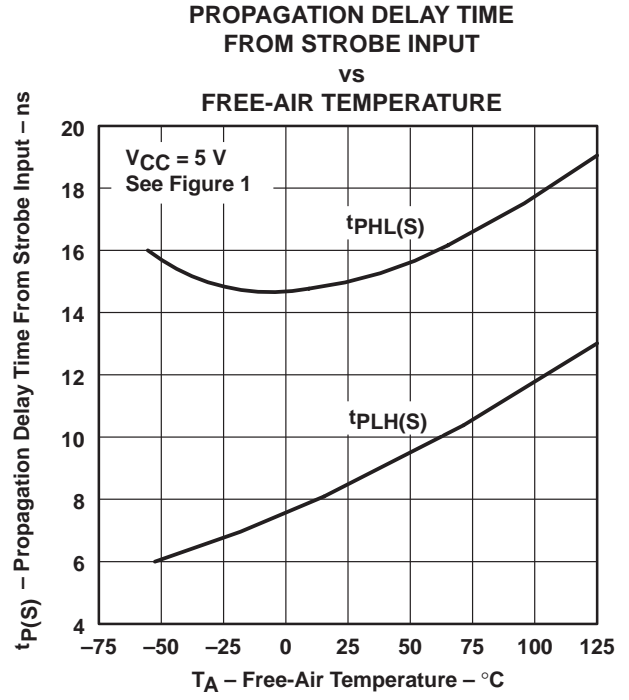
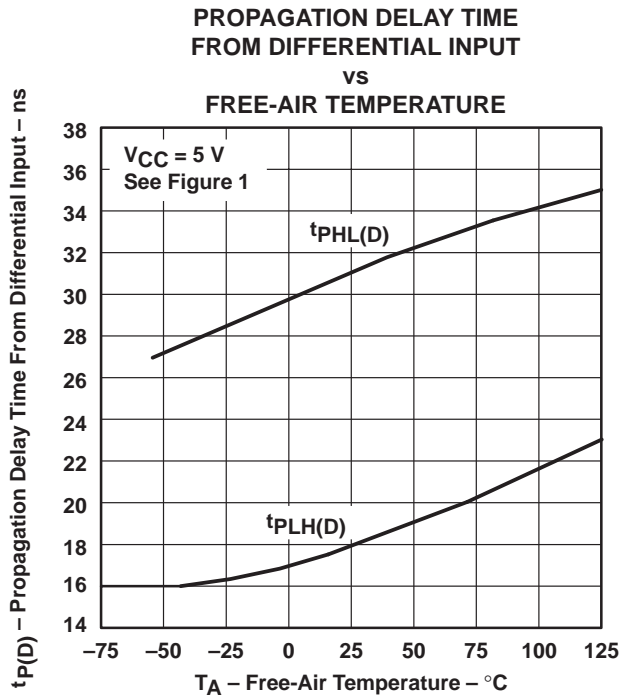

† Operation of the device at these or any other conditions beyond those indicated under "recommended operating conditions" is not implied.

SN55182, SN75182 DUAL DIFFERENTIAL LINE RECEIVERS

SLLS092D – OCTOBER 1972 – REVISED APRIL 1998

APPLICATION INFORMATION

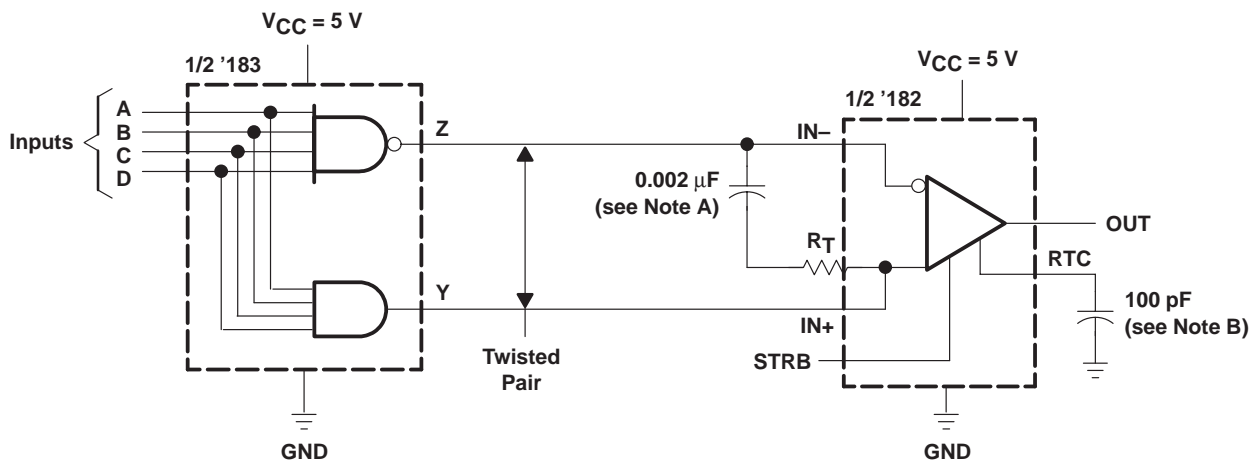

NOTES: A. When the inputs are open circuited, the output is high. A capacitor may be used for dc isolation of the line-terminating resistor. At the frequency of operation, the impedance of the capacitor should be relatively small.

Example: let $f = 5 \text{ MHz}$
 $C = 0.002 \mu\text{F}$

$$Z_{(C)} = \frac{1}{2\pi f C} = \frac{1}{2\pi(5 \times 10^6)(0.002 \times 10^{-6})}$$

$$Z_{(C)} \approx 16\Omega$$

B. Use of a capacitor to control response time is optional.

Figure 14. Transmission of Digital Data Over Twisted-Pair Line

PACKAGING INFORMATION

Orderable Device	Status (1)	Package Type	Package Drawing	Pins	Package Qty	Eco Plan (2)	Lead finish/ Ball material (6)	MSL Peak Temp (3)	Op Temp (°C)	Device Marking (4/5)	Samples
5962-7900801VCA	ACTIVE	CDIP	J	14	25	Non-RoHS & Green	SNPB	N / A for Pkg Type	-55 to 125	5962-7900801VC A SNV55182J	Samples
5962-7900801VDA	ACTIVE	CFP	W	14	25	Non-RoHS & Green	SNPB	N / A for Pkg Type	-55 to 125	5962-7900801VD A SNV55182W	Samples
SN75182D	ACTIVE	SOIC	D	14	50	RoHS & Green	NIPDAU	Level-1-260C-UNLIM	0 to 70	SN75182	Samples
SN75182DR	ACTIVE	SOIC	D	14	2500	RoHS & Green	NIPDAU	Level-1-260C-UNLIM	0 to 70	SN75182	Samples
SN75182N	ACTIVE	PDIP	N	14	25	RoHS & Green	NIPDAU	N / A for Pkg Type	0 to 70	SN75182N	Samples
SN75182NSR	ACTIVE	SO	NS	14	2000	RoHS & Green	NIPDAU	Level-1-260C-UNLIM	0 to 70	SN75182	Samples

(1) The marketing status values are defined as follows:

ACTIVE: Product device recommended for new designs.

LIFEBUY: TI has announced that the device will be discontinued, and a lifetime-buy period is in effect.

NRND: Not recommended for new designs. Device is in production to support existing customers, but TI does not recommend using this part in a new design.

PREVIEW: Device has been announced but is not in production. Samples may or may not be available.

OBSELETE: TI has discontinued the production of the device.

(2) **RoHS:** TI defines "RoHS" to mean semiconductor products that are compliant with the current EU RoHS requirements for all 10 RoHS substances, including the requirement that RoHS substance do not exceed 0.1% by weight in homogeneous materials. Where designed to be soldered at high temperatures, "RoHS" products are suitable for use in specified lead-free processes. TI may reference these types of products as "Pb-Free".

RoHS Exempt: TI defines "RoHS Exempt" to mean products that contain lead but are compliant with EU RoHS pursuant to a specific EU RoHS exemption.

Green: TI defines "Green" to mean the content of Chlorine (Cl) and Bromine (Br) based flame retardants meet JS709B low halogen requirements of <=1000ppm threshold. Antimony trioxide based flame retardants must also meet the <=1000ppm threshold requirement.

(3) MSL, Peak Temp. - The Moisture Sensitivity Level rating according to the JEDEC industry standard classifications, and peak solder temperature.

(4) There may be additional marking, which relates to the logo, the lot trace code information, or the environmental category on the device.

(5) Multiple Device Markings will be inside parentheses. Only one Device Marking contained in parentheses and separated by a "~" will appear on a device. If a line is indented then it is a continuation of the previous line and the two combined represent the entire Device Marking for that device.

⁽⁶⁾ Lead finish/Ball material - Orderable Devices may have multiple material finish options. Finish options are separated by a vertical ruled line. Lead finish/Ball material values may wrap to two lines if the finish value exceeds the maximum column width.

Important Information and Disclaimer:The information provided on this page represents TI's knowledge and belief as of the date that it is provided. TI bases its knowledge and belief on information provided by third parties, and makes no representation or warranty as to the accuracy of such information. Efforts are underway to better integrate information from third parties. TI has taken and continues to take reasonable steps to provide representative and accurate information but may not have conducted destructive testing or chemical analysis on incoming materials and chemicals. TI and TI suppliers consider certain information to be proprietary, and thus CAS numbers and other limited information may not be available for release.

In no event shall TI's liability arising out of such information exceed the total purchase price of the TI part(s) at issue in this document sold by TI to Customer on an annual basis.

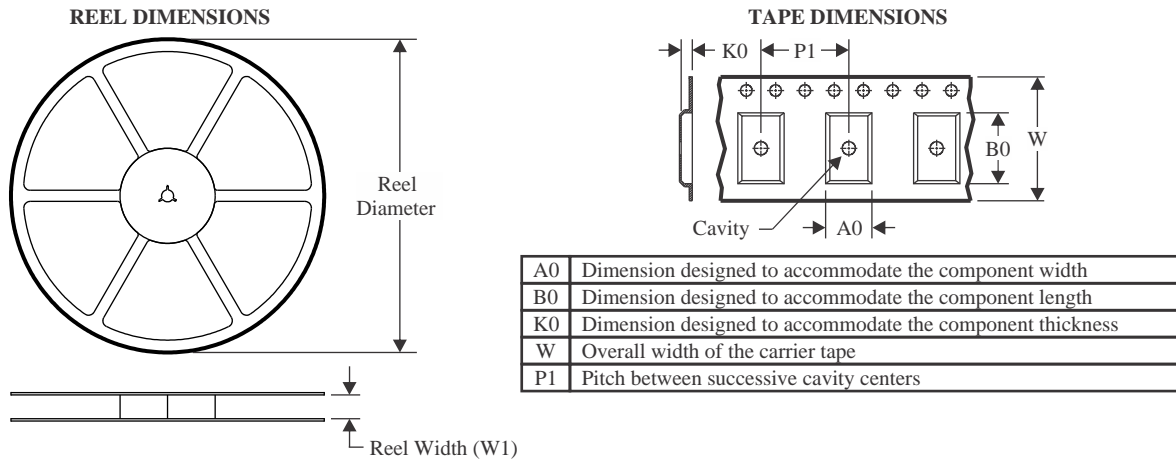
TAPE AND REEL INFORMATION

QUADRANT ASSIGNMENTS FOR PIN 1 ORIENTATION IN TAPE

*All dimensions are nominal

Device	Package Type	Package Drawing	Pins	SPQ	Reel Diameter (mm)	Reel Width W1 (mm)	A0 (mm)	B0 (mm)	K0 (mm)	P1 (mm)	W (mm)	Pin1 Quadrant
SN75182DR	SOIC	D	14	2500	330.0	16.4	6.5	9.0	2.1	8.0	16.0	Q1
SN75182NSR	SO	NS	14	2000	330.0	16.4	8.2	10.5	2.5	12.0	16.0	Q1

TAPE AND REEL BOX DIMENSIONS

*All dimensions are nominal

Device	Package Type	Package Drawing	Pins	SPQ	Length (mm)	Width (mm)	Height (mm)
SN75182DR	SOIC	D	14	2500	356.0	356.0	35.0
SN75182NSR	SO	NS	14	2000	356.0	356.0	35.0

TUBE

*All dimensions are nominal

Device	Package Name	Package Type	Pins	SPQ	L (mm)	W (mm)	T (μm)	B (mm)
5962-7900801VDA	W	CFP	14	25	506.98	26.16	6220	NA
SN75182D	D	SOIC	14	50	506.6	8	3940	4.32
SN75182N	N	PDIP	14	25	506	13.97	11230	4.32

MECHANICAL DATA

NS (R-PDSO-G**)

PLASTIC SMALL-OUTLINE PACKAGE

14-PINS SHOWN



- NOTES:
- A. All linear dimensions are in millimeters.
 - B. This drawing is subject to change without notice.
 - C. Body dimensions do not include mold flash or protrusion, not to exceed 0,15.

W (R-GDFP-F14)

CERAMIC DUAL FLATPACK



- NOTES:
- A. All linear dimensions are in inches (millimeters).
 - B. This drawing is subject to change without notice.
 - C. This package can be hermetically sealed with a ceramic lid using glass frit.
 - D. Index point is provided on cap for terminal identification only.
 - E. Falls within MIL STD 1835 GDFP1-F14

J 14

GENERIC PACKAGE VIEW
CDIP - 5.08 mm max height
CERAMIC DUAL IN LINE PACKAGE



Images above are just a representation of the package family, actual package may vary.
Refer to the product data sheet for package details.

4040083-5/G

J0014A



PACKAGE OUTLINE

CDIP - 5.08 mm max height

CERAMIC DUAL IN LINE PACKAGE



4214771/A 05/2017

NOTES:

1. All controlling linear dimensions are in inches. Dimensions in brackets are in millimeters. Any dimension in brackets or parenthesis are for reference only. Dimensioning and tolerancing per ASME Y14.5M.
2. This drawing is subject to change without notice.
3. This package is hermetically sealed with a ceramic lid using glass frit.
4. Index point is provided on cap for terminal identification only and on press ceramic glass frit seal only.
5. Falls within MIL-STD-1835 and GDIP1-T14.

EXAMPLE BOARD LAYOUT

J0014A

CDIP - 5.08 mm max height

CERAMIC DUAL IN LINE PACKAGE



LAND PATTERN EXAMPLE
NON-SOLDER MASK DEFINED
SCALE: 5X



4214771/A 05/2017

D (R-PDSO-G14)

PLASTIC SMALL OUTLINE

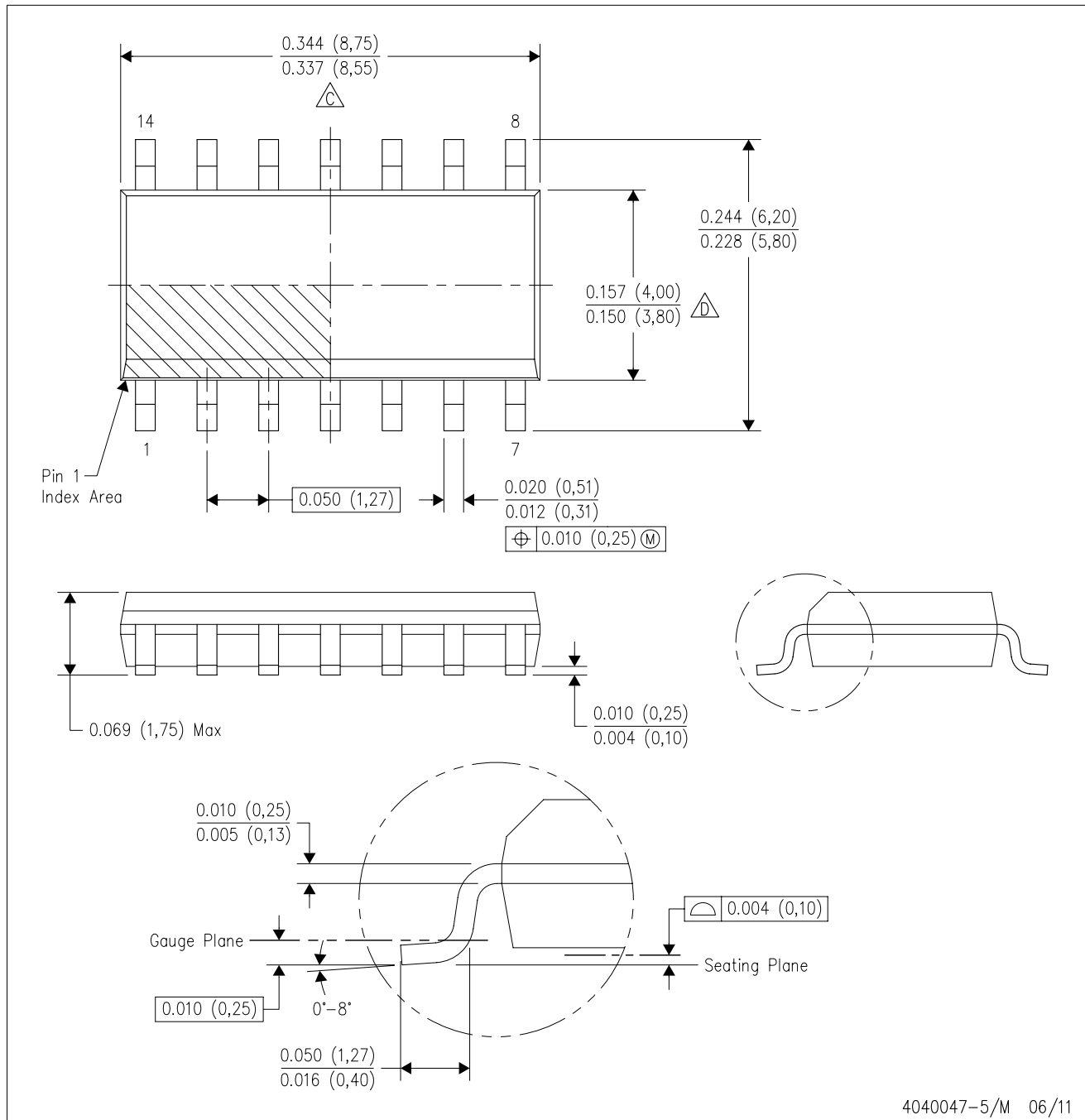

- NOTES:
- A. All linear dimensions are in inches (millimeters).
 - B. This drawing is subject to change without notice.
 -  Body length does not include mold flash, protrusions, or gate burrs. Mold flash, protrusions, or gate burrs shall not exceed 0.006 (0,15) each side.
 -  Body width does not include interlead flash. Interlead flash shall not exceed 0.017 (0,43) each side.
 - E. Reference JEDEC MS-012 variation AB.

D (R-PDSO-G14)

PLASTIC SMALL OUTLINE



- NOTES:
- A. All linear dimensions are in millimeters.
 - B. This drawing is subject to change without notice.
 - C. Publication IPC-7351 is recommended for alternate designs.
 - D. Laser cutting apertures with trapezoidal walls and also rounding corners will offer better paste release. Customers should contact their board assembly site for stencil design recommendations. Refer to IPC-7525 for other stencil recommendations.
 - E. Customers should contact their board fabrication site for solder mask tolerances between and around signal pads.

N (R-PDIP-T**)

PLASTIC DUAL-IN-LINE PACKAGE

16 PINS SHOWN



- NOTES:
- A. All linear dimensions are in inches (millimeters).
 - B. This drawing is subject to change without notice.
 - Falls within JEDEC MS-001, except 18 and 20 pin minimum body length (Dim A).
 - The 20 pin end lead shoulder width is a vendor option, either half or full width.

IMPORTANT NOTICE AND DISCLAIMER

TI PROVIDES TECHNICAL AND RELIABILITY DATA (INCLUDING DATA SHEETS), DESIGN RESOURCES (INCLUDING REFERENCE DESIGNS), APPLICATION OR OTHER DESIGN ADVICE, WEB TOOLS, SAFETY INFORMATION, AND OTHER RESOURCES "AS IS" AND WITH ALL FAULTS, AND DISCLAIMS ALL WARRANTIES, EXPRESS AND IMPLIED, INCLUDING WITHOUT LIMITATION ANY IMPLIED WARRANTIES OF MERCHANTABILITY, FITNESS FOR A PARTICULAR PURPOSE OR NON-INFRINGEMENT OF THIRD PARTY INTELLECTUAL PROPERTY RIGHTS.

These resources are intended for skilled developers designing with TI products. You are solely responsible for (1) selecting the appropriate TI products for your application, (2) designing, validating and testing your application, and (3) ensuring your application meets applicable standards, and any other safety, security, regulatory or other requirements.

These resources are subject to change without notice. TI grants you permission to use these resources only for development of an application that uses the TI products described in the resource. Other reproduction and display of these resources is prohibited. No license is granted to any other TI intellectual property right or to any third party intellectual property right. TI disclaims responsibility for, and you will fully indemnify TI and its representatives against, any claims, damages, costs, losses, and liabilities arising out of your use of these resources.

TI's products are provided subject to [TI's Terms of Sale](#) or other applicable terms available either on [ti.com](https://www.ti.com) or provided in conjunction with such TI products. TI's provision of these resources does not expand or otherwise alter TI's applicable warranties or warranty disclaimers for TI products.

TI objects to and rejects any additional or different terms you may have proposed.

Mailing Address: Texas Instruments, Post Office Box 655303, Dallas, Texas 75265
Copyright © 2024, Texas Instruments Incorporated

Looking for pricing, stock, or lifecycle information?

Click below to explore more details on WIN SOURCE:

 [View SN75182N on WIN SOURCE](#)

 [Texas Instruments](#) Information

Optimize Your Supply Chain with WIN SOURCE Solutions

-  Global Sourcing Solution
-  Obsolete Management
-  Cost Control Management
-  Shortage Management
-  Alternative Solution
-  Excess Inventory Management