



# THE DATASHEET OF SN75176AP



## SN75176A Differential Bus Transceiver

### 1 Features

- Bidirectional Transceiver
- Meets or Exceeds the Requirements of ANSI Standards EIA/TIA-422-B and ITU Recommendations V.11
- Designed for Multipoint Transmission on Long Bus Lines in Noisy Environments
- 3-State Driver and Receiver Outputs
- Individual Driver and Receiver Enables
- Wide Positive and Negative Input/Output Bus Voltage Ranges
- Driver Output Capability  $\pm 60$  mA Max
- Thermal-Shutdown Protection
- Driver Positive-Current Limiting and Negative-Current Limiting
- Receiver Input Impedance 12 k $\Omega$  Min
- Receiver Input Sensitivity  $\pm 200$  mV
- Receiver Input Hysteresis 50 mV Typ
- Operates From Single 5-V Supply
- Lower Power Requirements

### 2 Applications

- Low Speed RS485 communication (5 Mbps or less)
- For 10 Mbps, use SN75176B

### 3 Description

The SN75176A differential bus transceiver is a monolithic integrated circuit designed for bidirectional data communication on multipoint bus-transmission lines. It is designed for balanced transmission lines and meets ANSI Standard EIA/TIA-422-B and ITU Recommendation V.11.

The SN75176A combines a 3-state differential line driver and a differential input line receiver, both of which operate from a single 5-V power supply. The driver and receiver have active-high and active-low enables, respectively, that can be externally connected together to function as a direction control. The driver differential outputs and the receiver differential inputs are connected internally to form differential input/output (I/O) bus ports that are designed to offer minimum loading to the bus whenever the driver is disabled or  $V_{CC} = 0$ . These ports feature wide positive and negative common-mode voltage ranges making the device suitable for party-line applications.

The driver is designed to handle loads up to 60 mA of sink or source current. The driver features positive- and negative-current limiting and thermal shutdown for protection from line fault conditions. Thermal shutdown is designed to occur at a junction temperature of approximately 150°C. The receiver features a minimum input impedance of 12 k $\Omega$ , an input sensitivity of  $\pm 200$  mV, and a typical input hysteresis of 50 mV.

The SN75176A can be used in transmission-line applications employing the SN75172 and SN75174 quadruple differential line drivers and SN75173 and SN75175 quadruple differential line receivers.

The SN75176A is characterized for operation from 0°C to 70°C.

#### Device Information<sup>(1)</sup>

PART NUMBER	PACKAGE (PIN)	BODY SIZE (NOM)
SN75176A	SOIC (8)	4.90 mm x 3.91 mm
	PDIP (8)	9.81 mm x 6.35 mm

(1) For all available packages, see the orderable addendum at the end of the datasheet.

#### Simplified Schematics

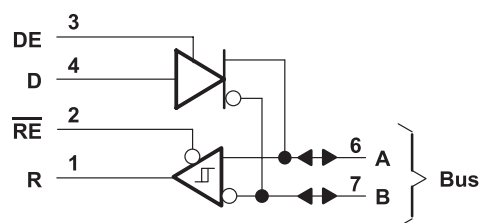
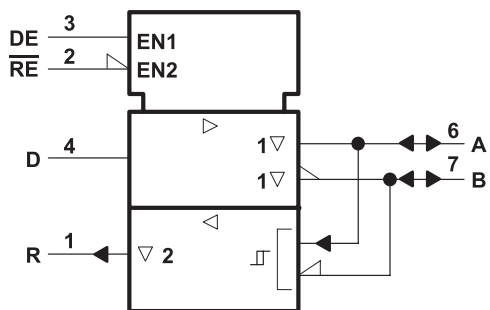

## Table of Contents

<b>1 Features</b> .....	<b>1</b>	8.1 Overview .....	11
<b>2 Applications</b> .....	<b>1</b>	8.2 Functional Block Diagrams .....	11
<b>3 Description</b> .....	<b>1</b>	8.3 Feature Description .....	12
<b>4 Revision History</b> .....	<b>2</b>	8.4 Device Functional Modes .....	12
<b>5 Pin Configuration and Functions</b> .....	<b>3</b>	<b>9 Application and Implementation</b> .....	<b>13</b>
<b>6 Specifications</b> .....	<b>4</b>	9.1 Application Information .....	13
6.1 Absolute Maximum Ratings .....	4	9.2 Typical Application .....	13
6.2 ESD Ratings .....	4	<b>10 Power Supply Recommendations</b> .....	<b>14</b>
6.3 Recommended Operating Conditions .....	4	<b>11 Layout</b> .....	<b>15</b>
6.4 Thermal Information .....	4	11.1 Layout Guidelines .....	15
6.5 Electrical Characteristics – Driver .....	5	11.2 Layout Example .....	15
6.6 Electrical Characteristics – Receiver .....	5	<b>12 Device and Documentation Support</b> .....	<b>15</b>
6.7 Switching Characteristics – Driver .....	6	12.1 Trademarks .....	15
6.8 Switching Characteristics – Receiver .....	6	12.2 Electrostatic Discharge Caution .....	15
6.9 Typical Characteristics .....	6	12.3 Glossary .....	15
<b>7 Parameter Measurement Information</b> .....	<b>8</b>	<b>13 Mechanical, Packaging, and Orderable Information</b> .....	<b>15</b>
<b>8 Detailed Description</b> .....	<b>11</b>		

## 4 Revision History

### Changes from Revision May (1995) to Revision B

**Page**

- Added *Applications*, *Device Information* table, *Pin Functions* table, *ESD Ratings* table, *Thermal Information* table, *Typical Characteristics*, *Feature Description* section, *Device Functional Modes*, *Application and Implementation* section, *Power Supply Recommendations* section, *Layout* section, *Device and Documentation Support* section, and *Mechanical, Packaging, and Orderable Information* section. .... **1**
- Deleted *Ordering Information* table. .... **1**

## 5 Pin Configuration and Functions

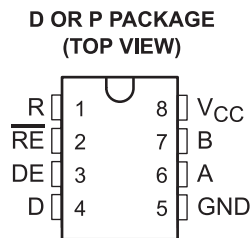

### Pin Functions

PIN		TYPE	DESCRIPTION
NAME	NO.		
R	1	O	Logic Data Output from RS-485 Receiver
$\overline{\text{RE}}$	2	I	Receive Enable (active low)
DE	3	I	Driver Enable (active high)
D	4	I	Logic Data Input to RS-485 Driver
GND	5	—	Device Ground Pin
A	6	I/O	RS-422 or RS-485 Data Line
B	7	I/O	RS-422 or RS-485 Data Line
$V_{\text{CC}}$	8	—	Power Input. Connect to 5-V Power Source.

## 6 Specifications

### 6.1 Absolute Maximum Ratings

over operating free-air temperature range (unless otherwise noted)<sup>(1)</sup>

		MIN	MAX	UNIT
$V_{CC}$	Supply Voltage <sup>(2)</sup>		7	V
	Voltage range at any bus terminal	-10	15	V
$V_I$	Enable input voltage		5.5	V
	Continuous Total power Dissipation	See <a href="#">Table 1</a>		
$T_A$	Operating free-air temperature range	0	70	°C
$T_{stg}$	Storage temperature range	65	150	°C

- (1) Stresses beyond those listed under *Absolute Maximum Ratings* may cause permanent damage to the device. These are stress ratings only, which do not imply functional operation of the device at these or any other conditions beyond those indicated under *Recommended Operating Conditions*. Exposure to absolute-maximum-rated conditions for extended periods may affect device reliability.
- (2) All voltage values, except differential input/output bus voltage, are with respect to network ground terminal.

### 6.2 ESD Ratings

		VALUE	UNIT
$V_{(ESD)}$	Electrostatic discharge	Human-body model (HBM), per ANSI/ESDA/JEDEC JS-001 <sup>(1)</sup>	±XXX
		Charged-device model (CDM), per JEDEC specification JESD22-C101 <sup>(2)</sup>	±YYY
			V

- (1) JEDEC document JEP155 states that 500-V HBM allows safe manufacturing with a standard ESD control process.
- (2) JEDEC document JEP157 states that 250-V CDM allows safe manufacturing with a standard ESD control process.

### 6.3 Recommended Operating Conditions

over operating free-air temperature range (unless otherwise noted)

		MIN	TYP	MAX	UNIT
$V_{CC}$	Supply Voltage	4.75	5	5.25	V
$V_I$ or $V_{IC}$	Voltage at any buss terminal (separately or common mode)	-7		12	V
$V_{IH}$	High-level input voltage	D, DE, and $\overline{RE}$			V
$V_{IL}$	Low-level input voltage	D, DE, and $\overline{RE}$		0.8	V
$V_{ID}$	Differential input voltage <sup>(1)</sup>			±12	V
$I_{OH}$	High-level output current	Driver		-60	mA
		Receiver		-400	µA
$I_{OL}$	Low-level output current	Driver		60	mA
		Receiver		8	
$T_A$	Operating free-air temperature	0		70	°C

- (1) Differential-input/output bus voltage is measured at the non-inverting terminal A with respect to the inverting terminal B.

### 6.4 Thermal Information

THERMAL METRIC <sup>(1)</sup>	SN75176A		UNIT	
	D	P		
	8 PINS	8 PINS		
$R_{\theta JA}$	Junction-to-ambient thermal resistance	172	113	°C/W

- (1) For more information about traditional and new thermal metrics, see the *IC Package Thermal Metrics* application report, [SPRA953](#).

**Table 1. Dissipation Rating Table**

PACKAGE	$T_A \leq 25^\circ\text{C}$ POWER RATING	DERATING FACTOR ABOVE $T_A = 25^\circ\text{C}$	$T_A = 70^\circ\text{C}$ POWER RATING
D	725 mW	5.8 mW/°C	464 mW
P	1100 mW	8.8 mW/°C	704 mW

## 6.5 Electrical Characteristics – Driver

over recommended ranges of supply voltage and operating free-air temperature (unless otherwise noted)

PARAMETER		TEST CONDITIONS	MIN	TYP <sup>(1)</sup>	MAX	UNIT
V <sub>IK</sub>	Input clamp voltage	I <sub>I</sub> = –18 mA			–1.5	V
V <sub>OH</sub>	High-level output voltage	V <sub>IH</sub> = 2 V, V <sub>IL</sub> = 0.8 V, I <sub>OH</sub> = –33 mA		3.7		V
V <sub>OL</sub>	Low-level output voltage	V <sub>IH</sub> = 2 V, V <sub>IL</sub> = 0.8 V, I <sub>OH</sub> = 33 mA		1.1		V
V <sub>OD1</sub>	Differential output voltage	I <sub>O</sub> = 0			2V <sub>OD2</sub>	V
V <sub>OD2</sub>	Differential output voltage	RL = 100 Ω, see <a href="#">Figure 8</a>	2	2.7		V
		RL = 54 Ω, see <a href="#">Figure 8</a>	1.5	2.4		
Δ V <sub>OD</sub>	Change in magnitude of differential output voltage <sup>(2)</sup>				±0.2	V
V <sub>OC</sub>	Common-mode output voltage <sup>(3)</sup>	RL = 54 Ω or 100 Ω, see <a href="#">Figure 8</a>			3	V
Δ V <sub>OC</sub>	Change in magnitude of common-mode output voltage <sup>(2)</sup>				±0.2	V
I <sub>O</sub>	Output current	Output disabled <sup>(4)</sup>	V <sub>O</sub> = 12 V		1	mA
			V <sub>O</sub> = –7 V		–0.8	
I <sub>IH</sub>	High-level input current	V <sub>I</sub> = 2.4 V			20	μA
I <sub>IL</sub>	Low-level input current	V <sub>I</sub> = 0.4 V			–400	μA
I <sub>OS</sub>	Short-circuit output current	V <sub>O</sub> = –7 V			–250	mA
		V <sub>O</sub> = V <sub>CC</sub>			250	
		V <sub>O</sub> = 12 V			500	
I <sub>CC</sub>	Supply current (total package)	No load	Outputs enabled	35	50	mA
			Outputs disabled	26	40	

(1) All typical values are at V<sub>CC</sub> = 5 V and T<sub>A</sub> = 25°C.

(2) Δ|V<sub>OD</sub>| and Δ|V<sub>OC</sub>| are the changes in magnitude of V<sub>OD</sub> and V<sub>OC</sub> respectively, that occur when the input is changed from a high level to a low level.

(3) In ANSI Standard EIA/TIA-422-B, V<sub>OC</sub>, which is the average of the two output voltages with respect to GND, is called output offset voltage, V<sub>OS</sub>.

(4) This applies for both power on and off; refer to ANSI Standard EIA/TIA-422-B for exact conditions.

## 6.6 Electrical Characteristics – Receiver

over recommended ranges of supply voltage and operating free-air temperature (unless otherwise noted)

PARAMETER		TEST CONDITIONS	MIN	TYP <sup>(1)</sup>	MAX	UNIT
V <sub>IT+</sub>	Positive-going input threshold voltage	V <sub>O</sub> = 2.7 V, I <sub>O</sub> = –0.4 mA			0.2	V
V <sub>IT–</sub>	Negative-going input threshold voltage	V <sub>O</sub> = 0.5 V, I <sub>O</sub> = 8 mA	–0.2			V
V <sub>hys</sub>	Input hysteresis voltage (V <sub>IT+</sub> – V <sub>IT–</sub> )			50		mV
V <sub>IK</sub>	Enable clamp voltage	I <sub>I</sub> = –18 mA			–1.5	V
V <sub>OH</sub>	High-level output voltage	V <sub>ID</sub> = 200 mV, I <sub>OH</sub> = –400 μA See <a href="#">Figure 9</a>	2.7			V
V <sub>OL</sub>	Low-level output voltage	V <sub>ID</sub> = 200 mV, I <sub>OH</sub> = 8 mA See <a href="#">Figure 9</a>			0.45	V
I <sub>OZ</sub>	High-impedance-state output current	V <sub>O</sub> = 0.4 V to 2.4 V			±20	μA
I <sub>I</sub>	Line input current	Other input = 0 V <sup>(2)</sup>	V <sub>I</sub> = 12 V		1	mA
			V <sub>I</sub> = –7 V		–0.8	
I <sub>IH</sub>	High-level enable input current	V <sub>IH</sub> = 2.7 V			20	μA
I <sub>IL</sub>	Low-level enable input current	V <sub>IL</sub> = 0.4 V			–100	μA
r <sub>i</sub>	Input resistance		12			kΩ
I <sub>OS</sub>	Short-circuit output current		–15		–85	mA
I <sub>CC</sub>	Supply current (total package)	No load	Outputs enabled	35	50	mA
			Outputs disabled	26	40	

(1) All typical values are at V<sub>CC</sub> = 5 V, T<sub>A</sub> = 25°C.

(2) This applies for both power on and power off. Refer to ANSI Standard EIA/TIA-422-B for exact conditions.

### 6.7 Switching Characteristics – Driver

$V_{CC} = 5\text{ V}$ ,  $T_A = 25^\circ\text{C}$

PARAMETER	TEST CONDITIONS	MIN	TYP	MAX	UNIT
$t_{d(OD)}$ Differential-output delay time	$R_L = 60\ \Omega$ , See <a href="#">Figure 10</a>		40	60	ns
$t_{t(OD)}$ Differential-output transition time			65	95	ns
$t_{PZH}$ Output enable time to high level	$R_L = 110\ \Omega$ , See <a href="#">Figure 11</a>		55	90	ns
$t_{PZL}$ Output enable time to low level	$R_L = 110\ \Omega$ , See <a href="#">Figure 12</a>		30	50	ns
$t_{PHZ}$ Output disable time form high level	$R_L = 110\ \Omega$ , See <a href="#">Figure 11</a>		85	130	ns
$t_{PLZ}$ Output disable time from low level	$R_L = 110\ \Omega$ , See <a href="#">Figure 12</a>		20	40	ns

### 6.8 Switching Characteristics – Receiver

$V_{CC} = 5\text{ V}$ ,  $C_L = 15\text{ pF}$ ,  $T_A = 25^\circ\text{C}$

PARAMETER	TEST CONDITIONS	MIN	TYP	MAX	UNIT
$t_{PLH}$ Propagation delay time, low-to-high-level output	$V_{ID} = -1.5\text{ V to }1.5\text{ V}$ , See <a href="#">Figure 13</a>		21	35	ns
$t_{PHL}$ Propagation delay time, high-to-low-level output			23	35	ns
$t_{PZH}$ Output enable time to high level	See <a href="#">Figure 14</a>		10	30	ns
$t_{PZL}$ Output enable time to low level			12	30	ns
$t_{PHZ}$ Output disable time from high level	See <a href="#">Figure 14</a>		20	35	ns
$t_{PLZ}$ Output disable time from low level			17	25	ns

### 6.9 Typical Characteristics

Conditions listed in each chart

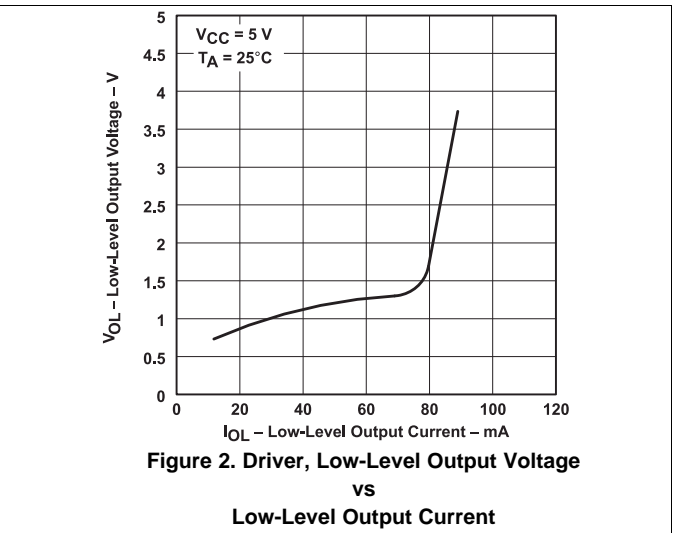
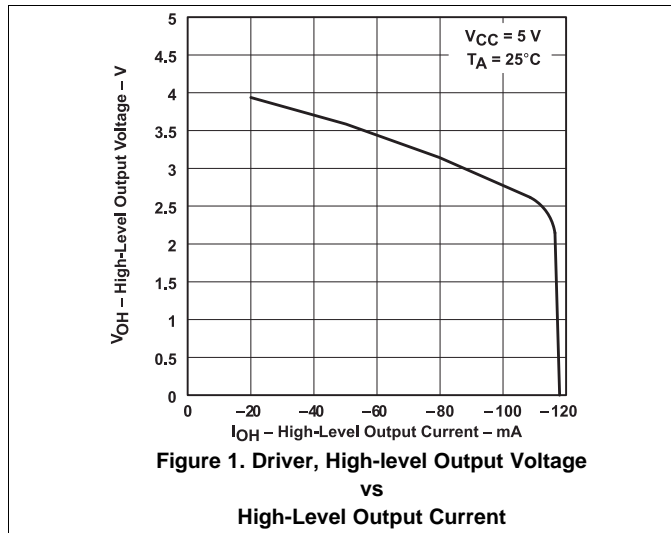

Typical Characteristics (continued)

Conditions listed in each chart

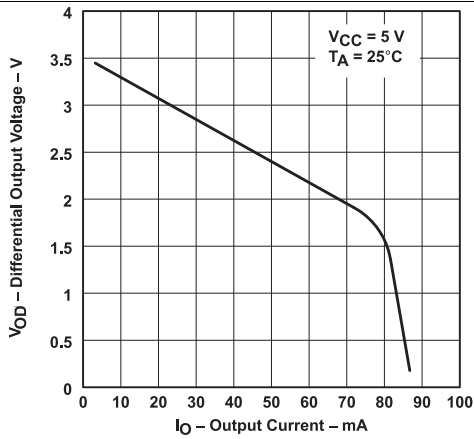

Figure 3. Driver, Differential Output Voltage vs Output Current

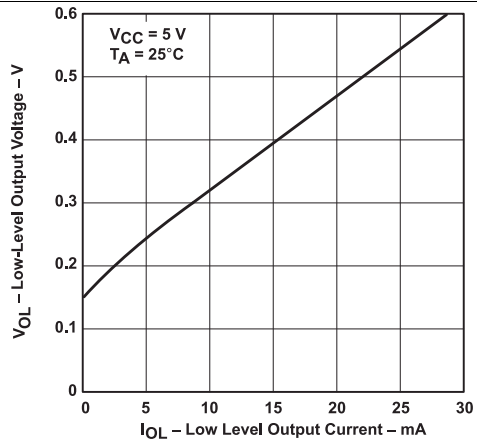

Figure 4. Receiver, Low-Level Output Voltage vs Low-Level Output Current

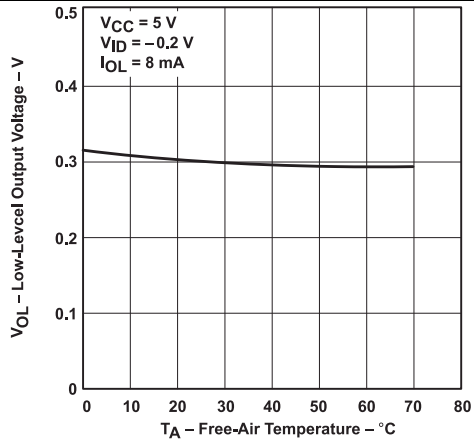

Figure 5. Receiver, Low-Level Output Voltage vs Low-Level Output Current

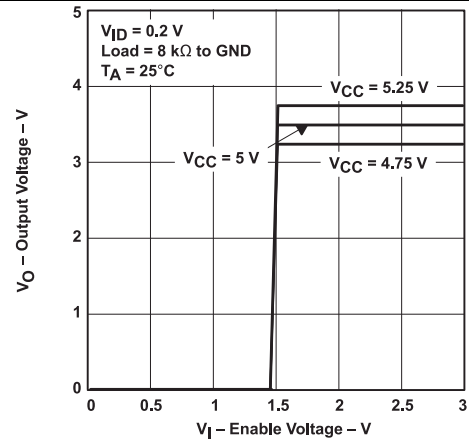

Figure 6. Low-Level Output Voltage vs Free-Air Temperature

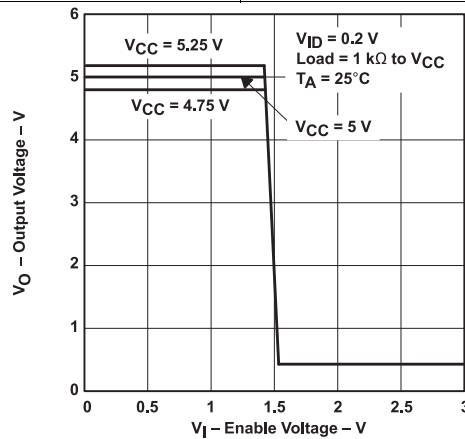

Figure 7. Output Voltage vs Enable Voltage

## 7 Parameter Measurement Information

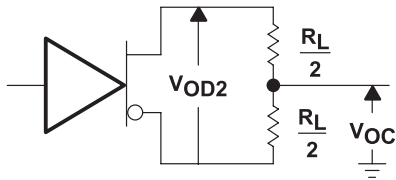

Figure 8. Driver  $V_{OD}$  and  $V_{OC}$

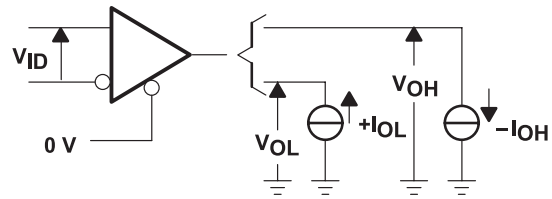
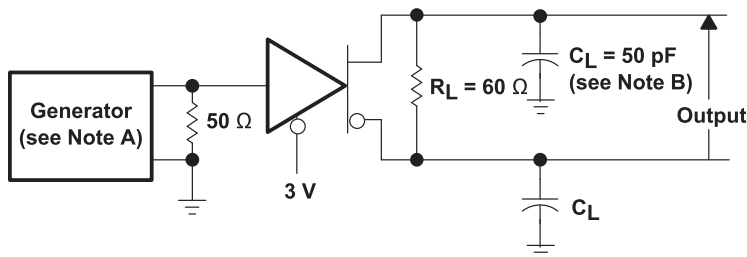

Figure 9. Receiver  $V_{OH}$  and  $V_{OL}$



TEST CIRCUIT

- A. The input pulse is supplied by a generator having the following characteristics: PRR = 1 MHz, 50% duty cycle,  $t_r \leq 6$  ns,  $t_f \leq 6$  ns,  $Z_O = 50 \Omega$ .
- B.  $C_L$  includes probe and jig capacitance.

Figure 10. Driver Test Circuit and Voltage Waveforms

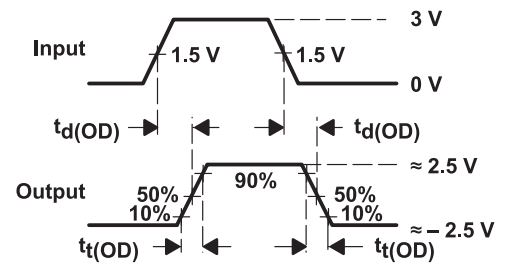

VOLTAGE WAVEFORMS

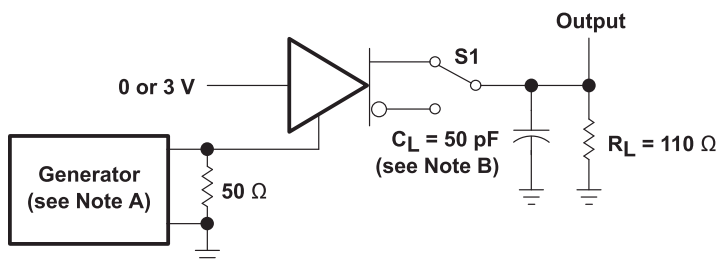

TEST CIRCUIT

- A. The input pulse is supplied by a generator having the following characteristics: PRR = 1 MHz, 50% duty cycle,  $t_r \leq 6$  ns,  $t_f \leq 6$  ns,  $Z_O = 50 \Omega$ .
- B.  $C_L$  includes probe and jig capacitance.

Figure 11. Driver Test Circuit and Voltage Waveforms

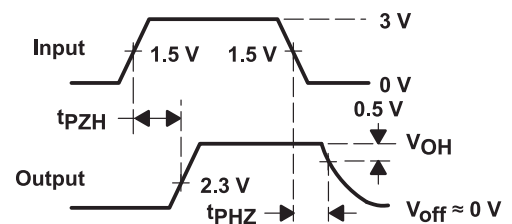

VOLTAGE WAVEFORMS

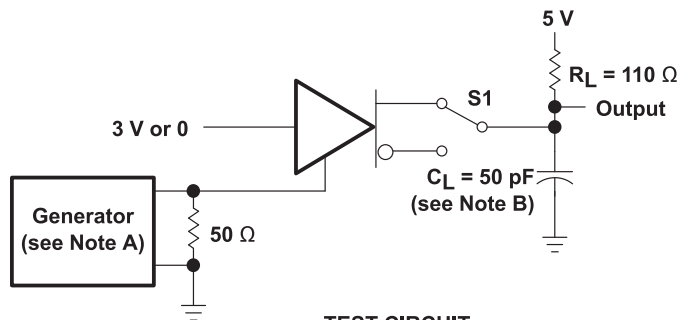

TEST CIRCUIT

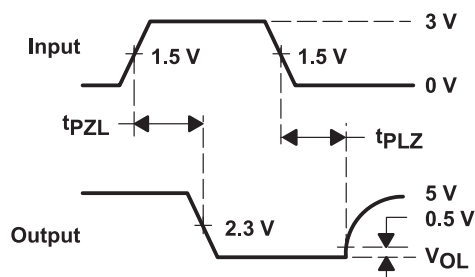

VOLTAGE WAVEFORMS

- A. The input pulse is supplied by a generator having the following characteristics: PRR = 1 MHz, 50% duty cycle,  $t_r \leq 6$  ns,  $t_f \leq 6$  ns,  $Z_O = 50 \Omega$ .
- B.  $C_L$  includes probe and jig capacitance.

Figure 12. Driver Test Circuit and Voltage Waveforms

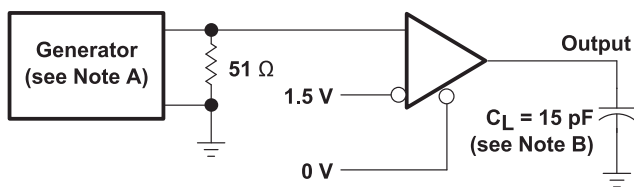

TEST CIRCUIT

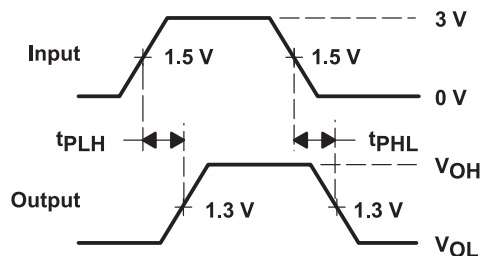

VOLTAGE WAVEFORMS

- A. The input pulse is supplied by a generator having the following characteristics: PRR = 1 MHz, 50% duty cycle,  $t_r \leq 6$  ns,  $t_f \leq 6$  ns,  $Z_O = 50 \Omega$ .
- B.  $C_L$  includes probe and jig capacitance.

Figure 13. Receiver Test Circuit and Voltage Waveforms

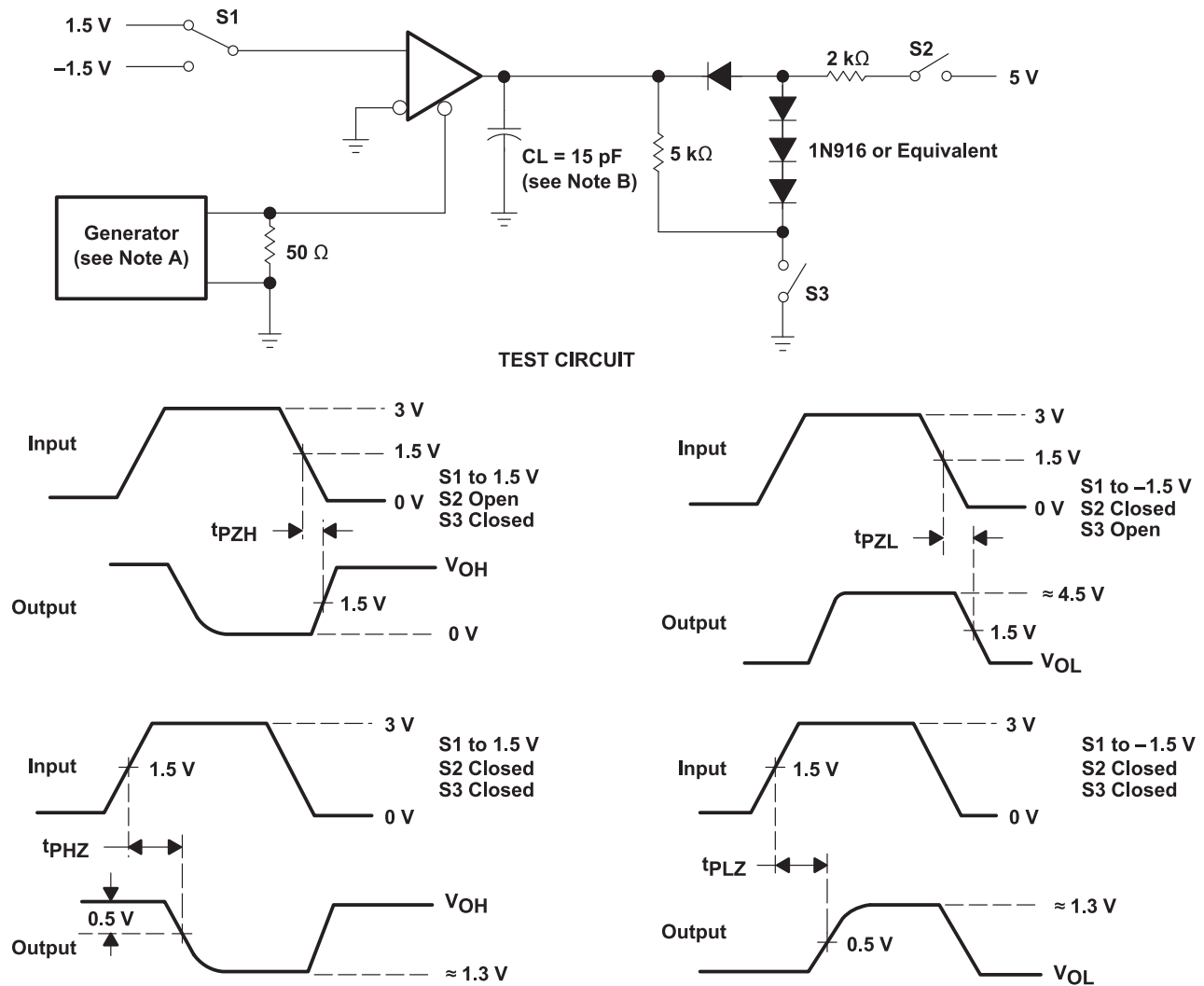

- A. The input pulse is supplied by a generator having the following characteristics: PRR = 1 MHz, 50% duty cycle,  $t_r \leq 6$  ns,  $t_f \leq 6$  ns,  $Z_O = 50 \Omega$ .
- B.  $C_L$  includes probe and jig capacitance.

**Figure 14. Receiver Test Circuit and voltage Waveforms**

## 8 Detailed Description

### 8.1 Overview

The SN75176A differential bus transceiver is a monolithic integrated circuit designed for bidirectional data communication on multipoint bus-transmission lines. It is designed for balanced transmission lines and meets ANSI Standard EIA/TIA-422-B and ITU Recommendation V.11.

The SN75176A combines a 3-state differential line driver and a differential input line receiver, both of which operate from a single 5-V power supply. The driver and receiver have active-high and active-low enables, respectively, that can be externally connected together to function as a direction control. The driver differential outputs and the receiver differential inputs are connected internally to form differential input/output (I/O) bus ports that are designed to offer minimum loading to the bus whenever the driver is disabled or  $V_{CC} = 0$ . These ports feature wide positive and negative common-mode voltage ranges making the device suitable for party-line applications.

The driver is designed to handle loads up to 60 mA of sink or source current. The driver features positive- and negative-current limiting and thermal shutdown for protection from line fault conditions. Thermal shutdown is designed to occur at a junction temperature of approximately 150°C. The receiver features a minimum input impedance of 12 k $\Omega$ , an input sensitivity of  $\pm 200$  mV, and a typical input hysteresis of 50 mV.

### 8.2 Functional Block Diagrams

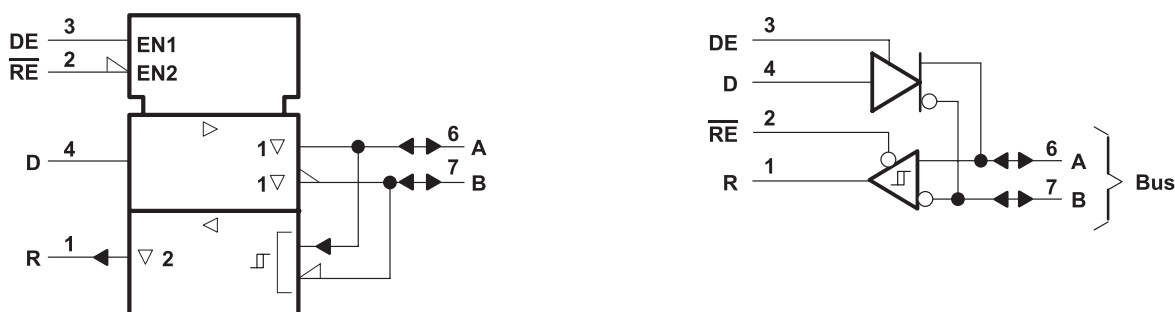

This symbol is in accordance with ANSI/IEEE Std 91-1984 and IEC Publication 617-12

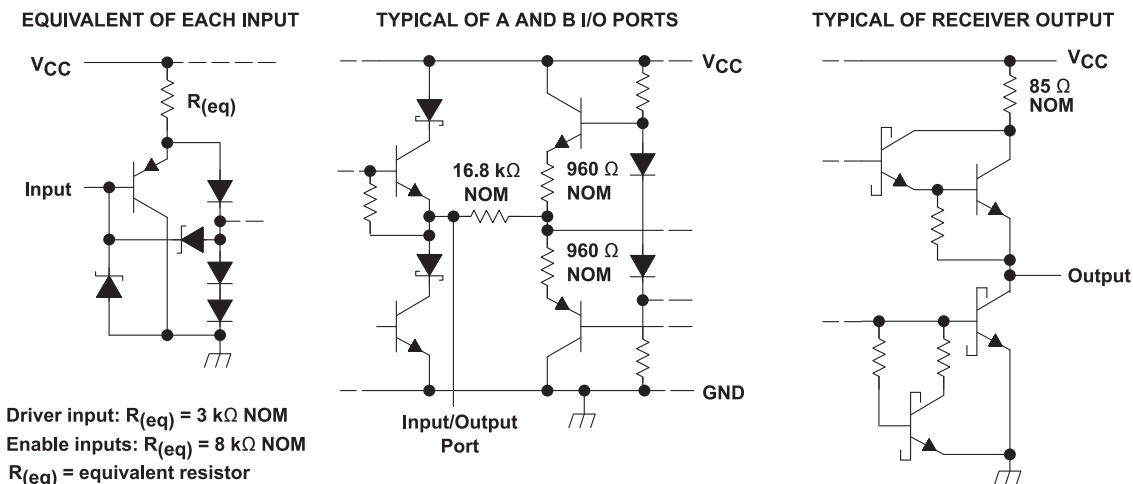

Figure 15. Schematics of Inputs and Outputs

## 8.3 Feature Description

### 8.3.1 Driver

The driver converts a TTL logic signal level to RS-422 and RS-485 compliant differential output. The TTL logic input, DE pin, can be used to turn the driver on and off.

**Table 2. Driver Function Table<sup>(1)</sup>**

INPUT D	ENABLE DE	DIFFERENTIAL OUTPUTS	
		A	B
H	H	H	L
L	H	L	H
X	L	Z	Z

(1) H = high level, L = low level,  
X = irrelevant, Z = high impedance (off)

### 8.3.2 Receiver

The receiver converts a RS-422 or RS-485 differential input voltage to a TTL logic level output. The TTL logic input,  $\overline{RE}$  pin, can be used to turn the receiver logic output on and off.

**Table 3. Receiver Function Table<sup>(1)</sup>**

DIFFERENTIAL INPUTS A–B	ENABLE $\overline{RE}$	OUTPUT R
$V_{ID} \geq 0.2 \text{ V}$	L	H
$-0.2 \text{ V} < V_{ID} < 0.2 \text{ V}$	L	U
$V_{ID} \leq -0.2 \text{ V}$	L	L
X	H	Z
Open	L	U

(1) H = high level,  
L = low level,  
U = unknown,  
Z = high impedance (off)

## 8.4 Device Functional Modes

### 8.4.1 Device Powered

Both the driver and receiver can be individually enabled or disabled in any combination. DE and  $\overline{RE}$  can be connected together for a single port direction control bit.

### 8.4.2 Device Unpowered

The driver differential outputs and the receiver differential inputs are connected internally to form differential input/output (I/O) bus ports that are designed to offer minimum loading to the bus when the driver is disabled or  $V_{CC} = 0$ .

## 9 Application and Implementation

### NOTE

Information in the following applications sections is not part of the TI component specification, and TI does not warrant its accuracy or completeness. TI's customers are responsible for determining suitability of components for their purposes. Customers should validate and test their design implementation to confirm system functionality.

### 9.1 Application Information

The device can be used in RS-485 and RS-422 physical layer communications.

### 9.2 Typical Application

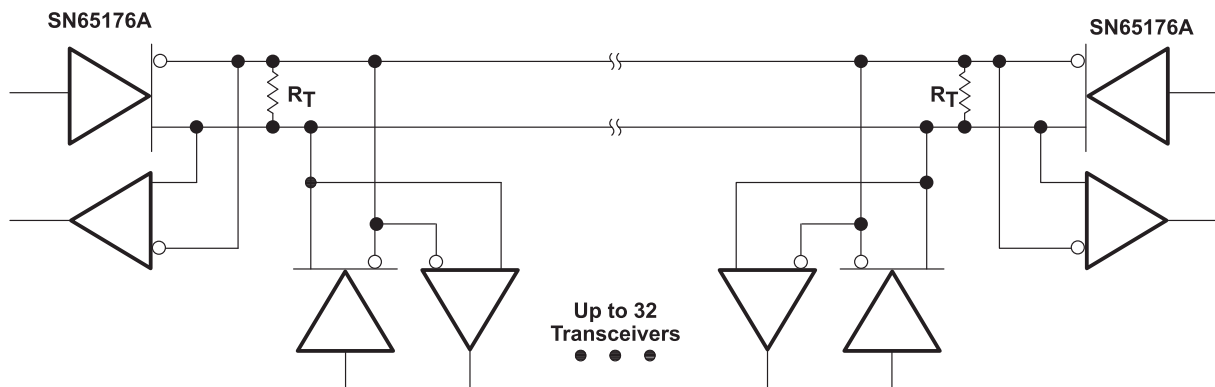

The line should be terminated at both ends in its characteristic impedance ( $R_T = Z_0$ ). Stub lengths off the main line should be kept as short as possible.

Figure 16. Typical Application Circuit

#### 9.2.1 Design Requirements

- 5-V power source
- RS-485 bus operating at 5 Mbps or less
- Connector that ensures the correct polarity for port pins
- External fail safe implementation

#### 9.2.2 Detailed Design Procedure

- Place the device close to bus connector to keep traces (stub) short to prevent adding reflections to the bus line
- If desired, add external fail-safe biasing to ensure +200 mV on the A-B port.

## Typical Application (continued)

### 9.2.3 Application Curves

A. Scale is 1V per division and 50nS per division

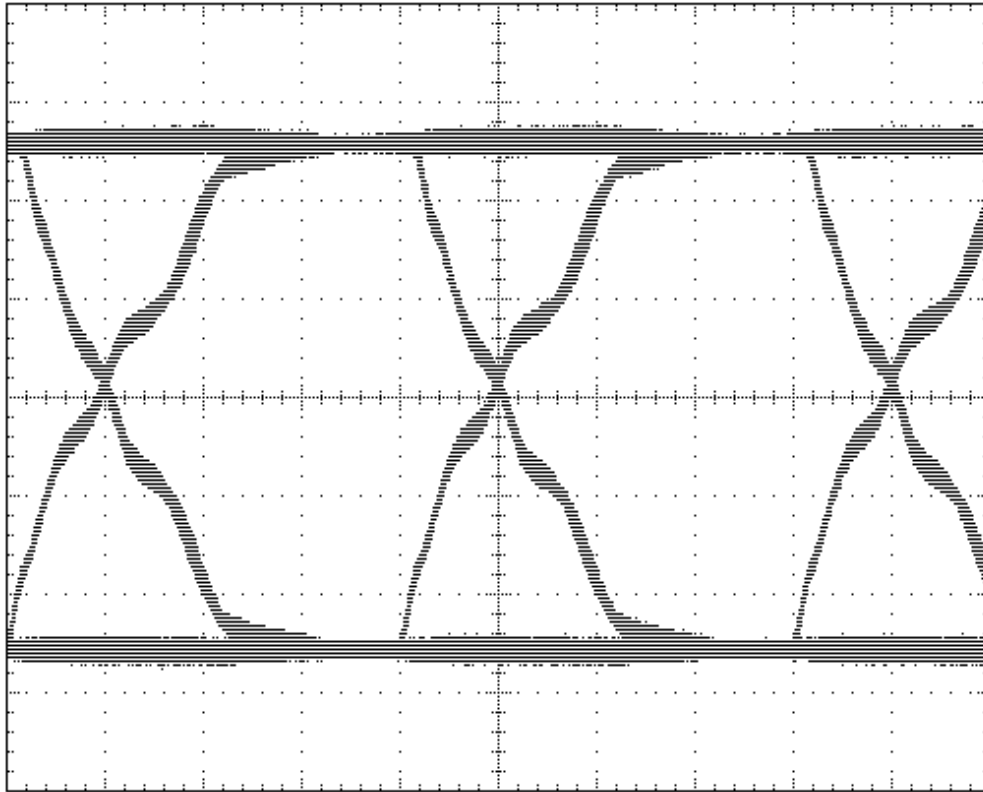

**Figure 17. Eye Diagram for 5-Mbps Over 100 feet of Standard CAT-5E cable  
120- $\Omega$  Termination at Both Ends.**

## 10 Power Supply Recommendations

Power supply should be 5 V with a tolerance less than 10%

## 11 Layout

### 11.1 Layout Guidelines

Traces from device pins A and B to connector must be short and capable of 250 mA maximum current.

### 11.2 Layout Example

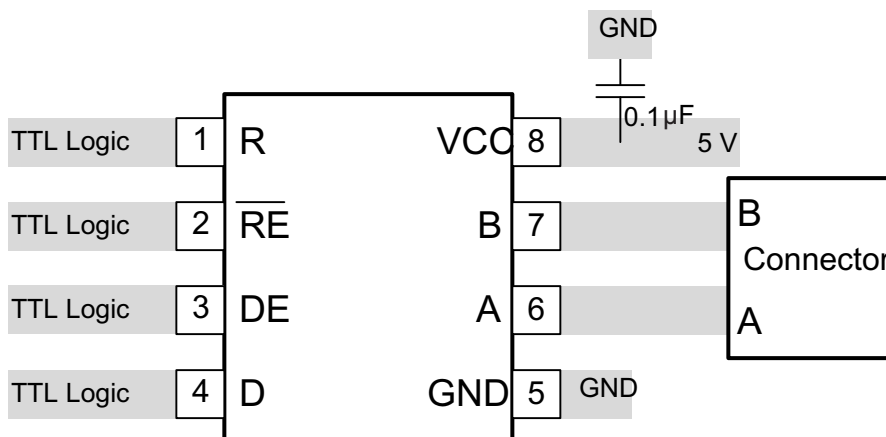

Figure 18. Layout Example

## 12 Device and Documentation Support

### 12.1 Trademarks

All trademarks are the property of their respective owners.

### 12.2 Electrostatic Discharge Caution



These devices have limited built-in ESD protection. The leads should be shorted together or the device placed in conductive foam during storage or handling to prevent electrostatic damage to the MOS gates.

### 12.3 Glossary

[SLYZ022](#) — *TI Glossary*.

This glossary lists and explains terms, acronyms, and definitions.

## 13 Mechanical, Packaging, and Orderable Information

The following pages include mechanical, packaging, and orderable information. This information is the most current data available for the designated devices. This data is subject to change without notice and revision of this document. For browser-based versions of this data sheet, refer to the left-hand navigation.

**PACKAGING INFORMATION**

Orderable Device	Status (1)	Package Type	Package Drawing	Pins	Package Qty	Eco Plan (2)	Lead/Ball Finish (6)	MSL Peak Temp (3)	Op Temp (°C)	Device Marking (4/5)	Samples
SN75176AD	ACTIVE	SOIC	D	8	75	Green (RoHS & no Sb/Br)	CU NIPDAU	Level-1-260C-UNLIM	0 to 70	75176A	<a href="#">Samples</a>
SN75176ADE4	ACTIVE	SOIC	D	8	75	Green (RoHS & no Sb/Br)	CU NIPDAU	Level-1-260C-UNLIM	0 to 70	75176A	<a href="#">Samples</a>
SN75176ADG4	ACTIVE	SOIC	D	8	75	Green (RoHS & no Sb/Br)	CU NIPDAU	Level-1-260C-UNLIM	0 to 70	75176A	<a href="#">Samples</a>
SN75176ADR	ACTIVE	SOIC	D	8	2500	Green (RoHS & no Sb/Br)	CU NIPDAU	Level-1-260C-UNLIM	0 to 70	75176A	<a href="#">Samples</a>
SN75176ADRE4	ACTIVE	SOIC	D	8	2500	Green (RoHS & no Sb/Br)	CU NIPDAU	Level-1-260C-UNLIM	0 to 70	75176A	<a href="#">Samples</a>
SN75176ADRG4	ACTIVE	SOIC	D	8	2500	Green (RoHS & no Sb/Br)	CU NIPDAU	Level-1-260C-UNLIM	0 to 70	75176A	<a href="#">Samples</a>
SN75176AP	ACTIVE	PDIP	P	8	50	Green (RoHS & no Sb/Br)	CU NIPDAU	N / A for Pkg Type	0 to 70	SN75176AP	<a href="#">Samples</a>
SN75176APE4	ACTIVE	PDIP	P	8	50	Green (RoHS & no Sb/Br)	CU NIPDAU	N / A for Pkg Type	0 to 70	SN75176AP	<a href="#">Samples</a>

(1) The marketing status values are defined as follows:

**ACTIVE:** Product device recommended for new designs.

**LIFEBUY:** TI has announced that the device will be discontinued, and a lifetime-buy period is in effect.

**NRND:** Not recommended for new designs. Device is in production to support existing customers, but TI does not recommend using this part in a new design.

**PREVIEW:** Device has been announced but is not in production. Samples may or may not be available.

**OBSOLETE:** TI has discontinued the production of the device.

(2) **RoHS:** TI defines "RoHS" to mean semiconductor products that are compliant with the current EU RoHS requirements for all 10 RoHS substances, including the requirement that RoHS substance do not exceed 0.1% by weight in homogeneous materials. Where designed to be soldered at high temperatures, "RoHS" products are suitable for use in specified lead-free processes. TI may reference these types of products as "Pb-Free".

**RoHS Exempt:** TI defines "RoHS Exempt" to mean products that contain lead but are compliant with EU RoHS pursuant to a specific EU RoHS exemption.

**Green:** TI defines "Green" to mean the content of Chlorine (Cl) and Bromine (Br) based flame retardants meet JS709B low halogen requirements of <=1000ppm threshold. Antimony trioxide based flame retardants must also meet the <=1000ppm threshold requirement.

(3) MSL, Peak Temp. - The Moisture Sensitivity Level rating according to the JEDEC industry standard classifications, and peak solder temperature.

(4) There may be additional marking, which relates to the logo, the lot trace code information, or the environmental category on the device.

<sup>(5)</sup> Multiple Device Markings will be inside parentheses. Only one Device Marking contained in parentheses and separated by a "-" will appear on a device. If a line is indented then it is a continuation of the previous line and the two combined represent the entire Device Marking for that device.

<sup>(6)</sup> Lead/Ball Finish - Orderable Devices may have multiple material finish options. Finish options are separated by a vertical ruled line. Lead/Ball Finish values may wrap to two lines if the finish value exceeds the maximum column width.

**Important Information and Disclaimer:**The information provided on this page represents TI's knowledge and belief as of the date that it is provided. TI bases its knowledge and belief on information provided by third parties, and makes no representation or warranty as to the accuracy of such information. Efforts are underway to better integrate information from third parties. TI has taken and continues to take reasonable steps to provide representative and accurate information but may not have conducted destructive testing or chemical analysis on incoming materials and chemicals. TI and TI suppliers consider certain information to be proprietary, and thus CAS numbers and other limited information may not be available for release.

In no event shall TI's liability arising out of such information exceed the total purchase price of the TI part(s) at issue in this document sold by TI to Customer on an annual basis.

## TAPE AND REEL INFORMATION



### QUADRANT ASSIGNMENTS FOR PIN 1 ORIENTATION IN TAPE



\*All dimensions are nominal

Device	Package Type	Package Drawing	Pins	SPQ	Reel Diameter (mm)	Reel Width W1 (mm)	A0 (mm)	B0 (mm)	K0 (mm)	P1 (mm)	W (mm)	Pin1 Quadrant
SN75176ADR	SOIC	D	8	2500	330.0	12.4	6.4	5.2	2.1	8.0	12.0	Q1

TAPE AND REEL BOX DIMENSIONS



\*All dimensions are nominal

Device	Package Type	Package Drawing	Pins	SPQ	Length (mm)	Width (mm)	Height (mm)
SN75176ADR	SOIC	D	8	2500	340.5	338.1	20.6



D0008A

# PACKAGE OUTLINE

SOIC - 1.75 mm max height

SMALL OUTLINE INTEGRATED CIRCUIT



4214825/C 02/2019

NOTES:

- Linear dimensions are in inches [millimeters]. Dimensions in parenthesis are for reference only. Controlling dimensions are in inches. Dimensioning and tolerancing per ASME Y14.5M.
- This drawing is subject to change without notice.
- This dimension does not include mold flash, protrusions, or gate burrs. Mold flash, protrusions, or gate burrs shall not exceed .006 [0.15] per side.
- This dimension does not include interlead flash.
- Reference JEDEC registration MS-012, variation AA.

# EXAMPLE BOARD LAYOUT

D0008A

SOIC - 1.75 mm max height

SMALL OUTLINE INTEGRATED CIRCUIT



LAND PATTERN EXAMPLE  
EXPOSED METAL SHOWN  
SCALE:8X



SOLDER MASK DETAILS

4214825/C 02/2019

NOTES: (continued)

- 6. Publication IPC-7351 may have alternate designs.
- 7. Solder mask tolerances between and around signal pads can vary based on board fabrication site.

# EXAMPLE STENCIL DESIGN

D0008A

SOIC - 1.75 mm max height

SMALL OUTLINE INTEGRATED CIRCUIT



SOLDER PASTE EXAMPLE  
BASED ON .005 INCH [0.125 MM] THICK STENCIL  
SCALE:8X

4214825/C 02/2019

NOTES: (continued)

8. Laser cutting apertures with trapezoidal walls and rounded corners may offer better paste release. IPC-7525 may have alternate design recommendations.
9. Board assembly site may have different recommendations for stencil design.

P (R-PDIP-T8)

PLASTIC DUAL-IN-LINE PACKAGE

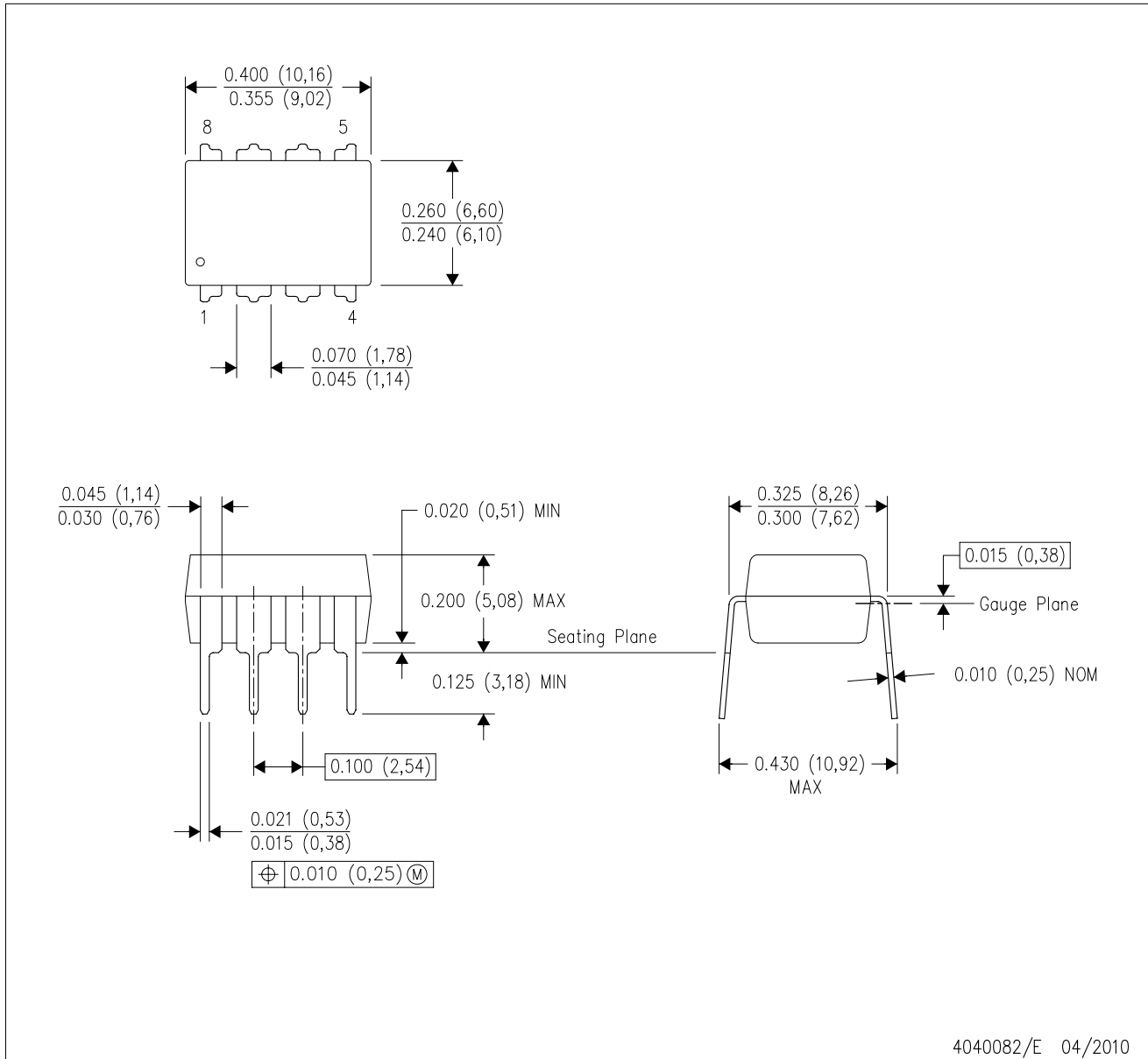

4040082/E 04/2010

- NOTES:
- A. All linear dimensions are in inches (millimeters).
  - B. This drawing is subject to change without notice.
  - C. Falls within JEDEC MS-001 variation BA.

## IMPORTANT NOTICE AND DISCLAIMER

TI PROVIDES TECHNICAL AND RELIABILITY DATA (INCLUDING DATASHEETS), DESIGN RESOURCES (INCLUDING REFERENCE DESIGNS), APPLICATION OR OTHER DESIGN ADVICE, WEB TOOLS, SAFETY INFORMATION, AND OTHER RESOURCES "AS IS" AND WITH ALL FAULTS, AND DISCLAIMS ALL WARRANTIES, EXPRESS AND IMPLIED, INCLUDING WITHOUT LIMITATION ANY IMPLIED WARRANTIES OF MERCHANTABILITY, FITNESS FOR A PARTICULAR PURPOSE OR NON-INFRINGEMENT OF THIRD PARTY INTELLECTUAL PROPERTY RIGHTS.

These resources are intended for skilled developers designing with TI products. You are solely responsible for (1) selecting the appropriate TI products for your application, (2) designing, validating and testing your application, and (3) ensuring your application meets applicable standards, and any other safety, security, or other requirements. These resources are subject to change without notice. TI grants you permission to use these resources only for development of an application that uses the TI products described in the resource. Other reproduction and display of these resources is prohibited. No license is granted to any other TI intellectual property right or to any third party intellectual property right. TI disclaims responsibility for, and you will fully indemnify TI and its representatives against, any claims, damages, costs, losses, and liabilities arising out of your use of these resources.

TI's products are provided subject to TI's Terms of Sale ([www.ti.com/legal/termsofsale.html](http://www.ti.com/legal/termsofsale.html)) or other applicable terms available either on [ti.com](http://ti.com) or provided in conjunction with such TI products. TI's provision of these resources does not expand or otherwise alter TI's applicable warranties or warranty disclaimers for TI products.

Mailing Address: Texas Instruments, Post Office Box 655303, Dallas, Texas 75265  
Copyright © 2019, Texas Instruments Incorporated

## Looking for pricing, stock, or lifecycle information?

Click below to explore more details on WIN SOURCE:

 [View SN75176AP](#) on WIN SOURCE

 [Texas Instruments](#) Information

## Optimize Your Supply Chain with WIN SOURCE Solutions

-  Global Sourcing Solution
-  Obsolete Management
-  Cost Control Management
-  Shortage Management
-  Alternative Solution
-  Excess Inventory Management