

- Meets IEEE Standard 488-1978 (GPIB)
- 8-Channel Bidirectional Transceiver
- Power-Up/Power-Down Protection (Glitch Free)
- High-Speed, Low-Power Schottky Circuitry
- Low Power Dissipation . . . 72 mW Max Per Channel
- Fast Propagation Times . . . 22 ns Max
- High-Impedance pnp Inputs
- Receiver Hysteresis . . . 650 mV Typ
- Open-Collector Driver Output Option
- No Loading of Bus When Device Is Powered Down ($V_{CC} = 0$)

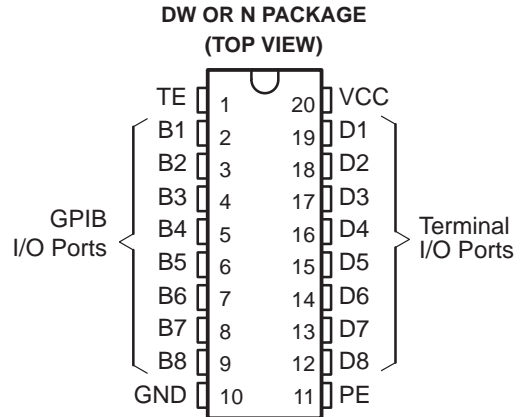

description

The SN75160B 8-channel general-purpose interface bus (GPIB) transceiver is a monolithic, high-speed, low-power Schottky device designed for two-way data communications over single-ended transmission lines. It is designed to meet the requirements of IEEE Standard 488-1978. The transceiver features driver outputs that can be operated in either the passive-pullup or 3-state mode. If talk enable (TE) is high, these ports have the characteristics of passive-pullup outputs when pullup enable (PE) is low and of 3-state outputs when PE is high. Taking TE low places these ports in the high-impedance state. The driver outputs are designed to handle loads up to 48 mA of sink current.

Output glitches during power up and power down are eliminated by an internal circuit that disables both the bus and receiver outputs. The outputs do not load the bus when $V_{CC} = 0$. When combined with the SN75161B or SN75162B management bus transceivers, the pair provides the complete 16-wire interface for the IEEE-488 bus.

The SN75160B is characterized for operation from 0°C to 70°C.

Function Tables

EACH DRIVER			
INPUTS			OUTPUT
D	TE	PE	B
H	H	H	H
L	H	X	L
H	X	L	Z†
X	L	X	Z†

EACH RECEIVER			
INPUTS			OUTPUT
B	TE	PE	D
L	L	X	L
H	L	X	H
X	H	X	Z

H = high level, L = low level, X = irrelevant, Z = high impedance

† This is the high-impedance state of a normal 3-state output modified by the internal resistors to V_{CC} and GND.



Please be aware that an important notice concerning availability, standard warranty, and use in critical applications of Texas Instruments semiconductor products and disclaimers thereto appears at the end of this data sheet.

SN75160B
OCTAL GENERAL-PURPOSE
INTERFACE BUS TRANSCEIVER
 SLLS004B – OCTOBER 1985 – REVISED MAY 1995

logic symbol†

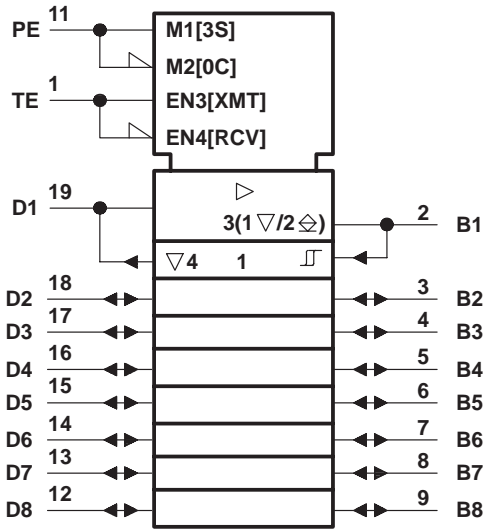

† This symbol is in accordance with ANSI/IEEE Std 91-1984 and IEC Publication 617-12.
 ▽ Designates 3-state outputs
 ◇ Designates passive-pullup outputs

logic diagram (positive logic)

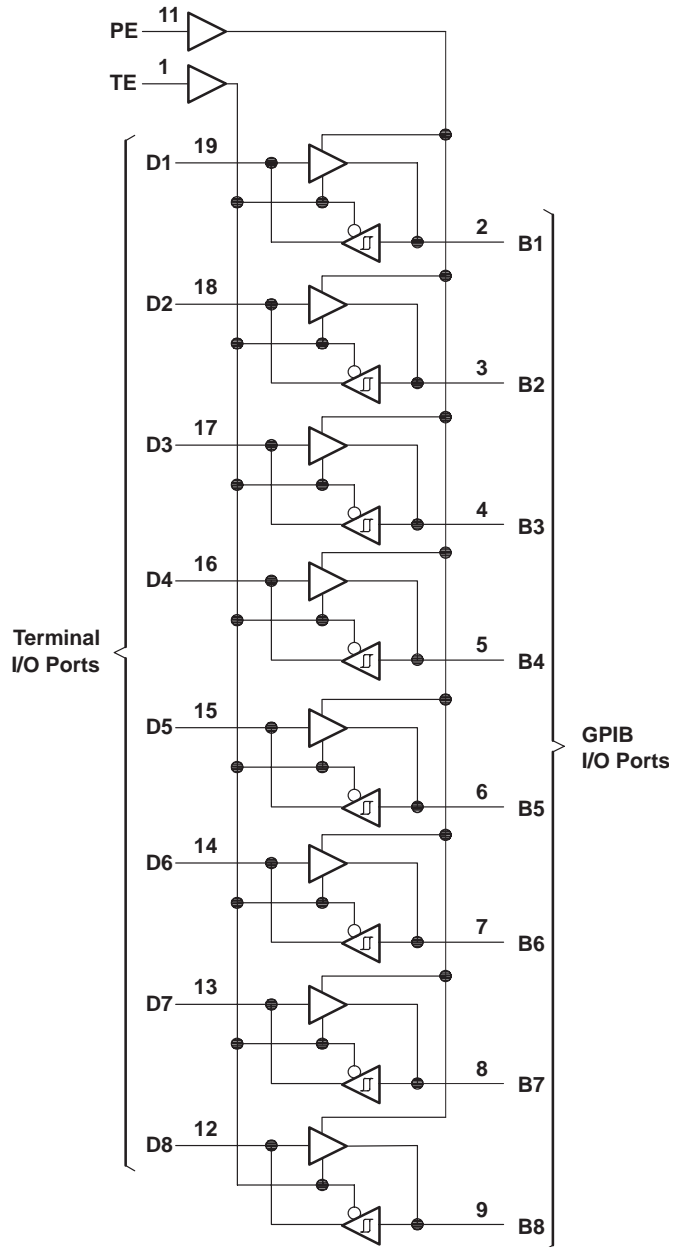

schematics of inputs and outputs

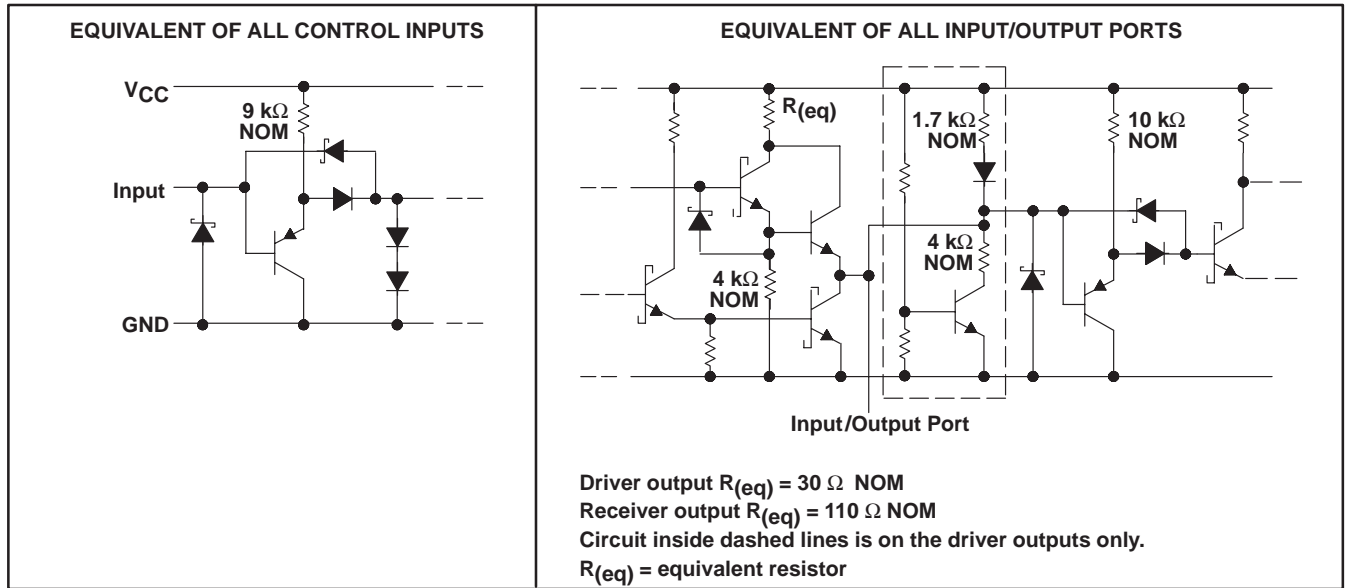

absolute maximum ratings over operating free-air temperature range (unless otherwise noted)†

Supply voltage, V_{CC} (see Note 1)	7 V
Input voltage, V_I	5.5 V
Low-level driver output current, I_{OL}	100 mA
Continuous total power dissipation	See Dissipation Rating Table
Operating free-air temperature range, T_A	0°C to 70°C
Storage temperature range, T_{stg}	-65°C to 150°C
Lead temperature 1,6 mm (1/16 inch) from case for 10 seconds	260°C

† Stresses beyond those listed under "absolute maximum ratings" may cause permanent damage to the device. These are stress ratings only, and functional operation of the device at these or any other conditions beyond those indicated under "recommended operating conditions" is not implied. Exposure to absolute-maximum-rated conditions for extended periods may affect device reliability.

NOTES: 1. All voltage values are with respect to network ground terminal.

DISSIPATION RATING TABLE

PACKAGE	$T_A \leq 25^\circ\text{C}$ POWER RATING	DERATING FACTOR ABOVE $T_A = 25^\circ\text{C}$	$T_A = 70^\circ\text{C}$ POWER RATING
DW	1125 mW	9.0 mW/°C	720 mW
N	1150 mW	9.2 mW/°C	736 mW

SN75160B

OCTAL GENERAL-PURPOSE INTERFACE BUS TRANSCEIVER

SLLS004B – OCTOBER 1985 – REVISED MAY 1995

recommended operating conditions

		MIN	NOM	MAX	UNIT
Supply voltage, V_{CC}		4.75	5	5.25	V
High-level input voltage, V_{IH}		2			V
Low-level input voltage, V_{IL}				0.8	V
High-level output current, I_{OH}	Bus ports with pullups active			-5.2	mA
	Terminal ports			-800	μ A
Low-level output current, I_{OL}	Bus ports			48	mA
	Terminal ports			16	
Operating free-air temperature, T_A		0		70	$^{\circ}$ C

electrical characteristics over recommended ranges of supply voltage and operating free-air temperature (unless otherwise noted)

PARAMETER		TEST CONDITIONS		MIN	TYP†	MAX	UNIT
V_{IK}	Input clamp voltage	$I_I = -18$ mA		-0.8	-1.5		V
V_{hys}	Hysteresis voltage ($V_{IT+} - V_{IT-}$)	Bus	See Figure 8	0.4	0.65		V
V_{OH}	High-level output voltage	Terminal	$I_{OH} = -800$ μ A, TE at 0.8 V	2.7	3.5		V
		Bus	$I_{OH} = -5.2$ mA, PE and TE at 2 V	2.5	3.3		
V_{OL}	Low-level output voltage	Terminal	$I_{OL} = 16$ mA, TE at 0.8 V	0.3	0.5		V
		Bus	$I_{OL} = 48$ mA, TE at 2 V	0.35	0.5		
I_I	Input current at maximum input voltage	Terminal	$V_I = 5.5$ V		0.2	100	μ A
I_{IH}	High-level input current	Terminal	$V_I = 2.7$ V		0.1	20	μ A
I_{IL}	Low-level input current	Terminal	$V_I = 0.5$ V		-10	-100	μ A
$V_{I/O(bus)}$	Voltage at bus port	Driver disabled	$I_{I(bus)} = 0$	2.5	3.0	3.7	V
			$I_{I(bus)} = -12$ mA			-1.5	
$I_{I/O(bus)}$	Current into bus port	Power on	Driver disabled	$V_{I(bus)} = -1.5$ V to 0.4 V	-1.3		mA
				$V_{I(bus)} = 0.4$ V to 2.5 V	0	-3.2	
				$V_{I(bus)} = 2.5$ V to 3.7 V		2.5	
				$V_{I(bus)} = 3.7$ V to 5 V	0	2.5	
				$V_{I(bus)} = 5$ V to 5.5 V	0.7	2.5	
		Power off	$V_{CC} = 0$, $V_{I(bus)} = 0$ to 2.5 V		-40		
I_{OS}	Short-circuit output current	Terminal		-15	-35	-75	mA
		Bus		-25	-50	-125	
I_{CC}	Supply current	No load	Receivers low and enabled		70	90	mA
			Drivers low and enabled		85	110	
$C_{I/O(bus)}$	Bus-port capacitance	$V_{CC} = 0$ to 5 V, $V_{I/O} = 0$ to 2 V, $f = 1$ MHz			16		pF

† All typical values are at $V_{CC} = 5$ V, $T_A = 25^{\circ}$ C.



switching characteristics, $V_{CC} = 5\text{ V}$, $C_L = 15\text{ pF}$, $T_A = 25^\circ\text{C}$ (unless otherwise noted)

PARAMETER		FROM (INPUT)	TO (OUTPUT)	TEST CONDITIONS	MIN	TYP	MAX	UNIT
t_{PLH}	Propagation delay time, low- to high-level output	Terminal	Bus	$C_L = 30\text{ pF}$, See Figure 1		14	20	ns
t_{PHL}	Propagation delay time, high- to low-level output					14	20	
t_{PLH}	Propagation delay time, low- to high-level output	Bus	Terminal	$C_L = 30\text{ pF}$, See Figure 2		10	20	ns
t_{PHL}	Propagation delay time, high- to low-level output					15	22	
t_{PZH}	Output enable time to high level	TE	BUS	See Figure 3		25	35	ns
t_{PHZ}	Output disable time from high level					13	22	
t_{PZL}	Output enable time to low level					22	35	
t_{PLZ}	Output disable time from low level					22	32	
t_{PZH}	Output enable time to high level	TE	Terminal	See Figure 4		20	30	ns
t_{PHZ}	Output disable time from high level					12	20	
t_{PZL}	Output enable time to low level					23	32	
t_{PLZ}	Output disable time from low level					19	30	
t_{en}	Output pullup enable time	PE	Bus	See Figure 5		15	22	ns
t_{dis}	Output pullup disable time					13	20	

PARAMETER MEASUREMENT INFORMATION

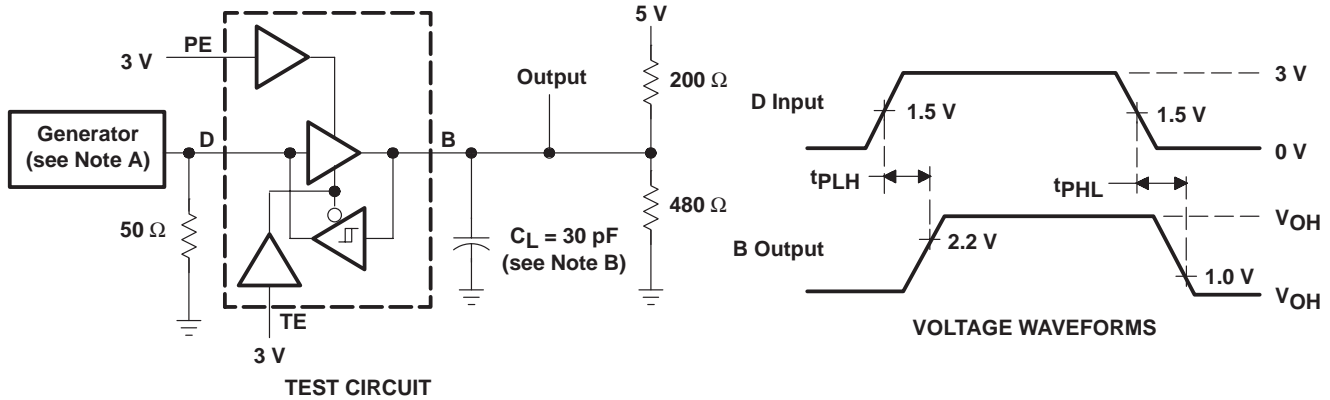

- NOTES: A. The input pulse is supplied by a generator having the following characteristics: PRR \leq 1 MHz, 50% duty cycle, $t_r \leq$ 6 ns, $t_f \leq$ ns, $Z_O = 50 \Omega$.
 B. C_L includes probe and jig capacitance.

Figure 1. Terminal-to-Bus Test Circuit and Voltage Waveforms

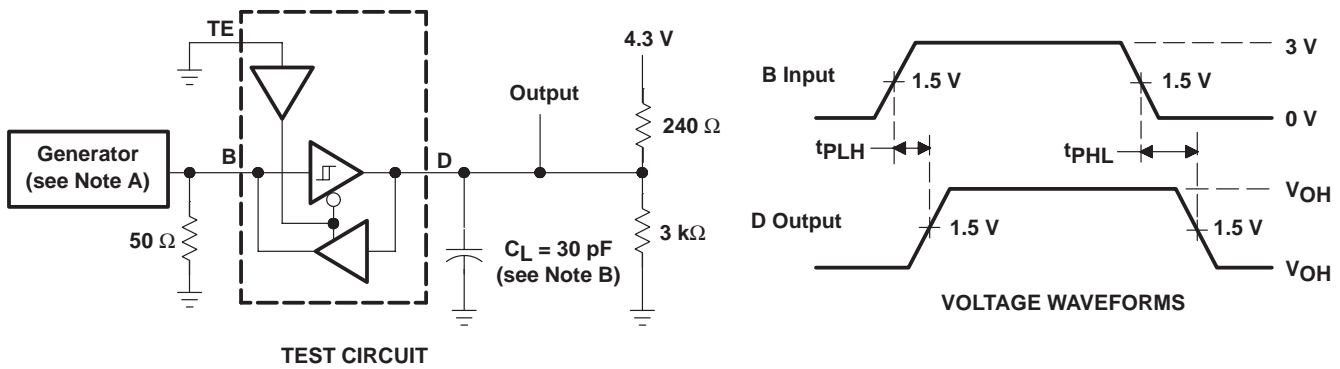

- NOTES: A. The input pulse is supplied by a generator having the following characteristics: PRR \leq 1 MHz, 50% duty cycle, $t_r \leq$ 6 ns, $t_f \leq$ ns, $Z_O = 50 \Omega$.
 B. C_L includes probe and jig capacitance.

Figure 2. Bus-to-Terminal Test Circuit and Voltage Waveforms

PARAMETER MEASUREMENT INFORMATION

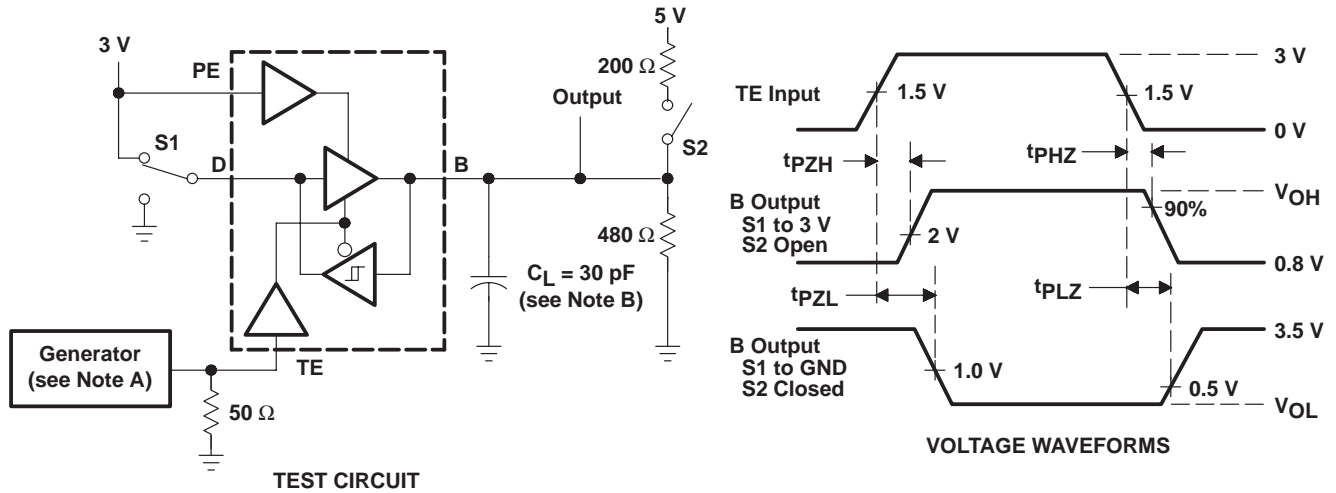

- NOTES: A. The input pulse is supplied by a generator having the following characteristics: $PRR \leq 1$ MHz, 50% duty cycle, $t_r \leq 6$ ns, $t_f \leq$ ns, $Z_O = 50 \Omega$.
B. C_L includes probe and jig capacitance.

Figure 3. TE-to-Bus Test Circuit and Voltage Waveforms

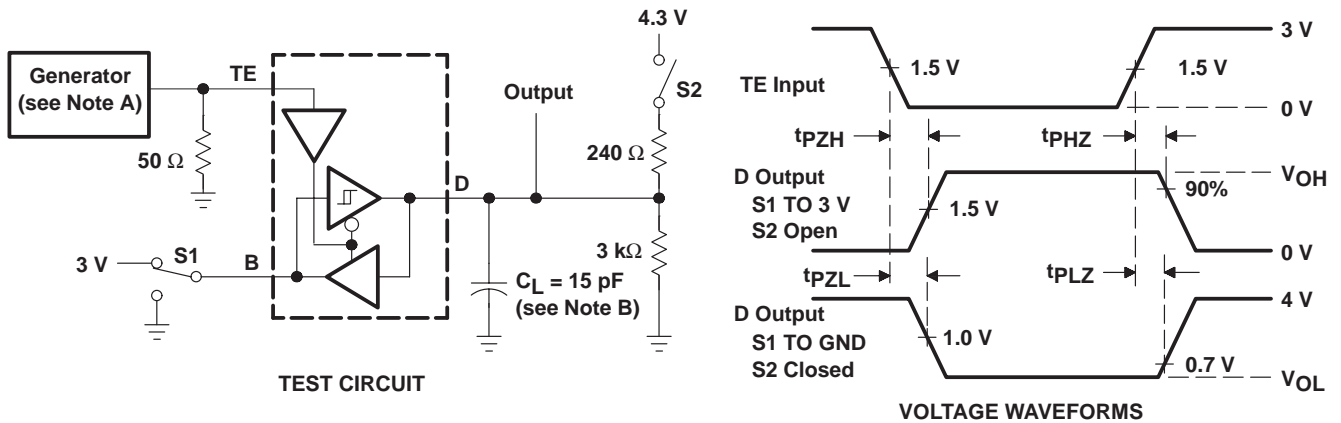

- NOTES: A. The input pulse is supplied by a generator having the following characteristics: $PRR \leq 1$ MHz, 50% duty cycle, $t_r \leq 6$ ns, $t_f \leq$ ns, $Z_O = 50 \Omega$.
B. C_L includes probe and jig capacitance.

Figure 4. TE-to-Terminal Test Circuit and Voltage Waveforms

PARAMETER MEASUREMENT INFORMATION

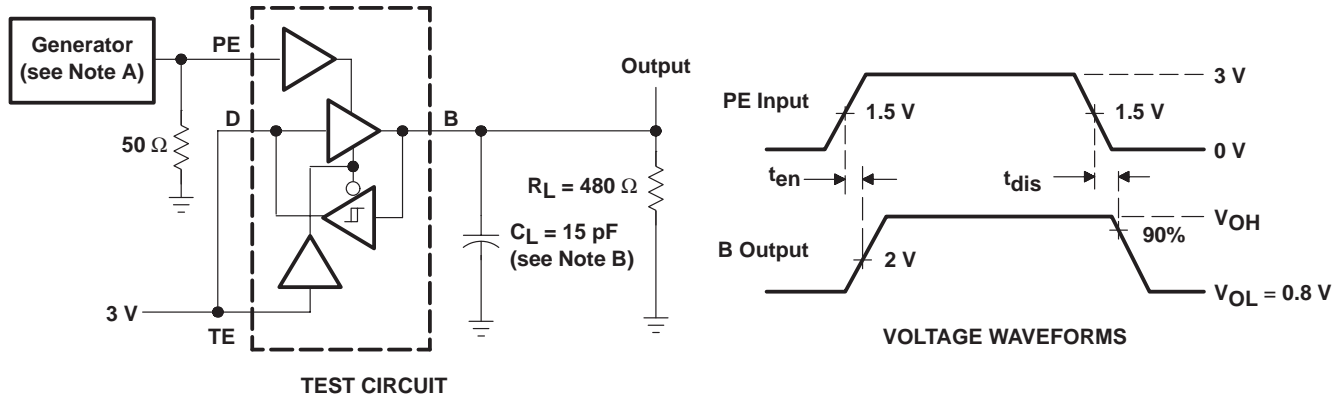

- NOTES: A. The input pulse is supplied by a generator having the following characteristics: PRR \leq 1 MHz, 50% duty cycle, $t_r \leq$ 6 ns, $t_f \leq$ ns, $Z_0 = 50 \Omega$.
 B. C_L includes probe and jig capacitance.

Figure 5. PE-to-Bus Pullup Test Circuit and Voltage Waveforms

TYPICAL CHARACTERISTICS

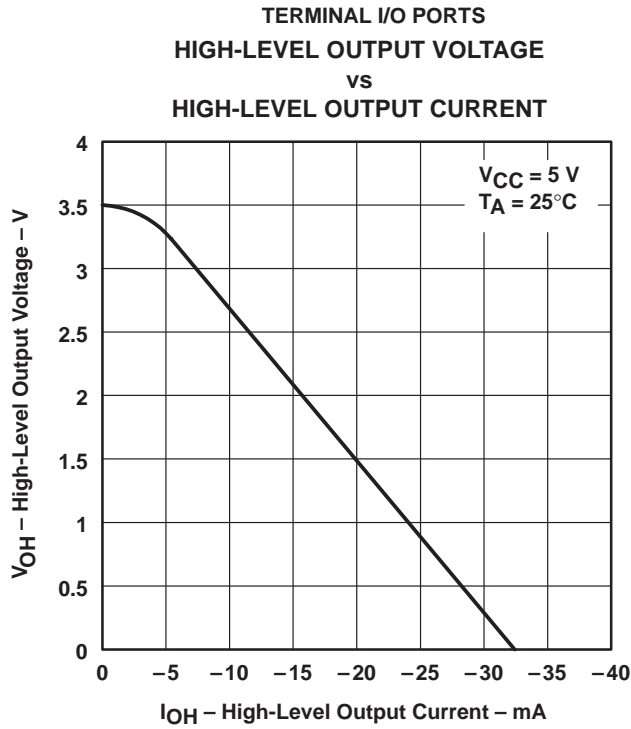

Figure 6

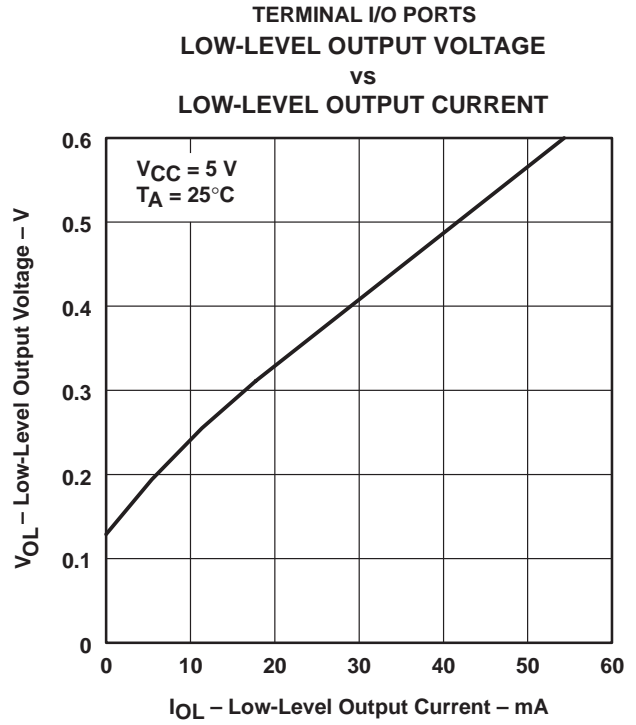

Figure 7

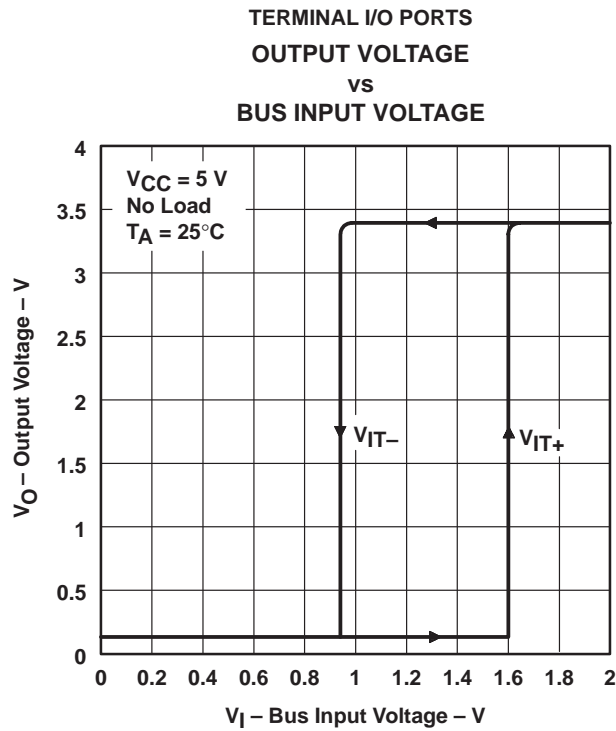

Figure 8

TYPICAL CHARACTERISTICS

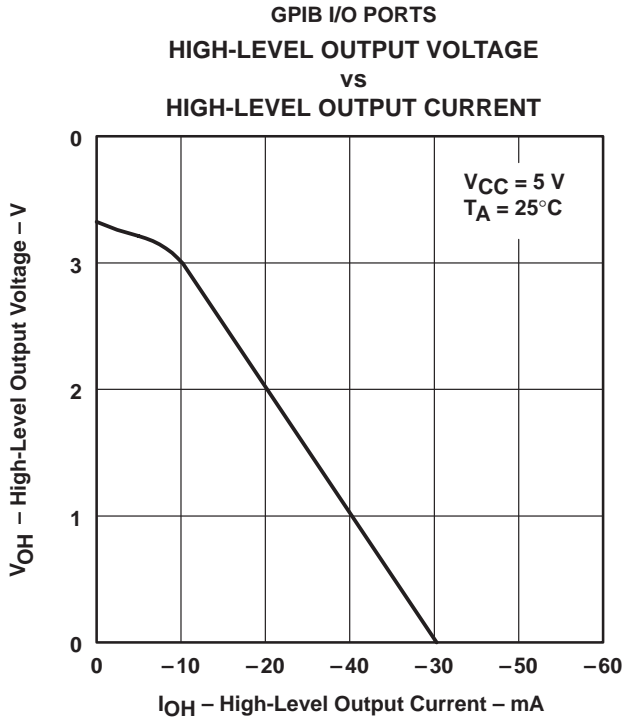

Figure 9

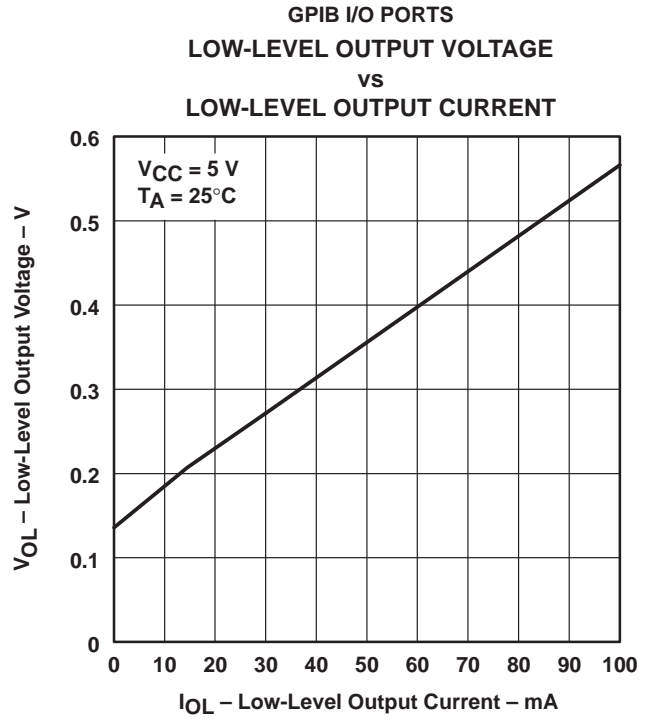

Figure 10

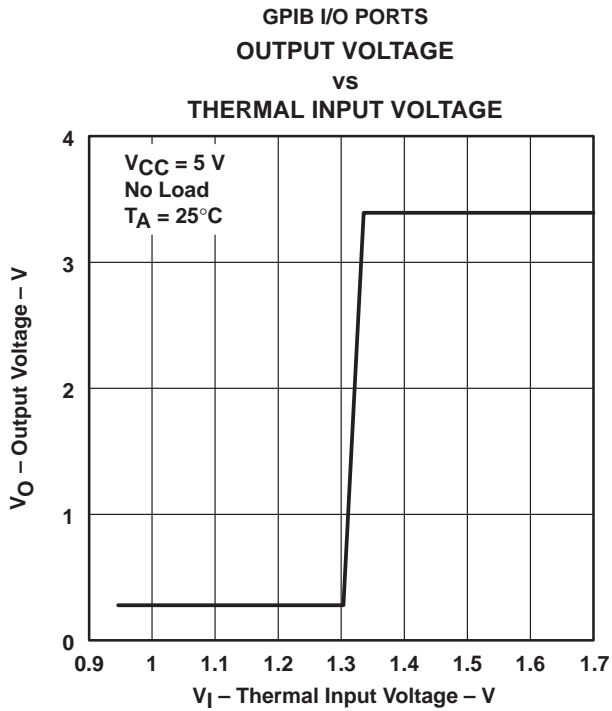

Figure 11

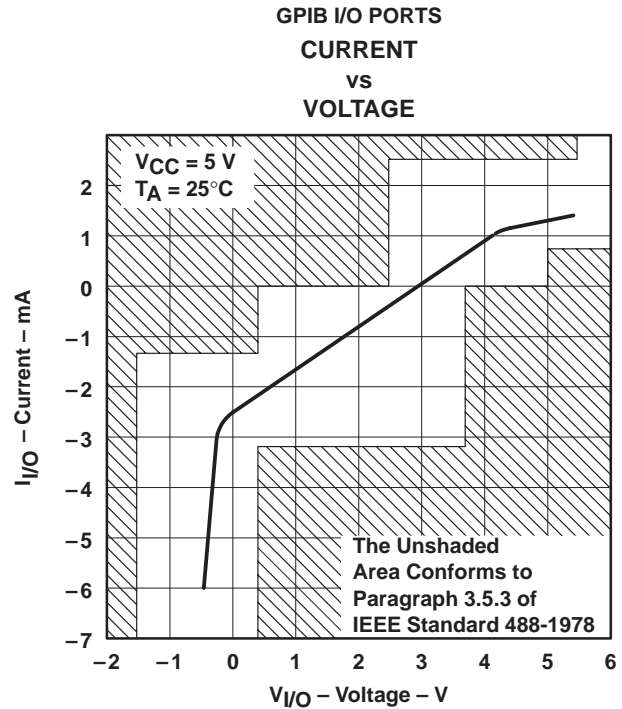

Figure 12

PACKAGING INFORMATION

Orderable Device	Status (1)	Package Type	Package Drawing	Pins	Package Qty	Eco Plan (2)	Lead finish/ Ball material (6)	MSL Peak Temp (3)	Op Temp (°C)	Device Marking (4/5)	Samples
SN75160BDW	ACTIVE	SOIC	DW	20	25	RoHS & Green	NIPDAU	Level-1-260C-UNLIM	0 to 70	SN75160B	Samples
SN75160BDWE4	ACTIVE	SOIC	DW	20	25	RoHS & Green	NIPDAU	Level-1-260C-UNLIM	0 to 70	SN75160B	Samples
SN75160BDWG4	ACTIVE	SOIC	DW	20	25	RoHS & Green	NIPDAU	Level-1-260C-UNLIM	0 to 70	SN75160B	Samples
SN75160BDWR	ACTIVE	SOIC	DW	20	2000	RoHS & Green	NIPDAU	Level-1-260C-UNLIM	0 to 70	SN75160B	Samples
SN75160BDWRE4	ACTIVE	SOIC	DW	20	2000	RoHS & Green	NIPDAU	Level-1-260C-UNLIM	0 to 70	SN75160B	Samples
SN75160BDWRG4	ACTIVE	SOIC	DW	20	2000	RoHS & Green	NIPDAU	Level-1-260C-UNLIM	0 to 70	SN75160B	Samples
SN75160BN	ACTIVE	PDIP	N	20	20	RoHS & Non-Green	NIPDAU	N / A for Pkg Type	0 to 70	SN75160BN	Samples

(1) The marketing status values are defined as follows:

ACTIVE: Product device recommended for new designs.

LIFEBUY: TI has announced that the device will be discontinued, and a lifetime-buy period is in effect.

NRND: Not recommended for new designs. Device is in production to support existing customers, but TI does not recommend using this part in a new design.

PREVIEW: Device has been announced but is not in production. Samples may or may not be available.

OBSELETE: TI has discontinued the production of the device.

(2) **RoHS:** TI defines "RoHS" to mean semiconductor products that are compliant with the current EU RoHS requirements for all 10 RoHS substances, including the requirement that RoHS substance do not exceed 0.1% by weight in homogeneous materials. Where designed to be soldered at high temperatures, "RoHS" products are suitable for use in specified lead-free processes. TI may reference these types of products as "Pb-Free".

RoHS Exempt: TI defines "RoHS Exempt" to mean products that contain lead but are compliant with EU RoHS pursuant to a specific EU RoHS exemption.

Green: TI defines "Green" to mean the content of Chlorine (Cl) and Bromine (Br) based flame retardants meet JS709B low halogen requirements of <=1000ppm threshold. Antimony trioxide based flame retardants must also meet the <=1000ppm threshold requirement.

(3) MSL, Peak Temp. - The Moisture Sensitivity Level rating according to the JEDEC industry standard classifications, and peak solder temperature.

(4) There may be additional marking, which relates to the logo, the lot trace code information, or the environmental category on the device.

(5) Multiple Device Markings will be inside parentheses. Only one Device Marking contained in parentheses and separated by a "~" will appear on a device. If a line is indented then it is a continuation of the previous line and the two combined represent the entire Device Marking for that device.

⁽⁶⁾ Lead finish/Ball material - Orderable Devices may have multiple material finish options. Finish options are separated by a vertical ruled line. Lead finish/Ball material values may wrap to two lines if the finish value exceeds the maximum column width.

Important Information and Disclaimer:The information provided on this page represents TI's knowledge and belief as of the date that it is provided. TI bases its knowledge and belief on information provided by third parties, and makes no representation or warranty as to the accuracy of such information. Efforts are underway to better integrate information from third parties. TI has taken and continues to take reasonable steps to provide representative and accurate information but may not have conducted destructive testing or chemical analysis on incoming materials and chemicals. TI and TI suppliers consider certain information to be proprietary, and thus CAS numbers and other limited information may not be available for release.

In no event shall TI's liability arising out of such information exceed the total purchase price of the TI part(s) at issue in this document sold by TI to Customer on an annual basis.

TAPE AND REEL INFORMATION

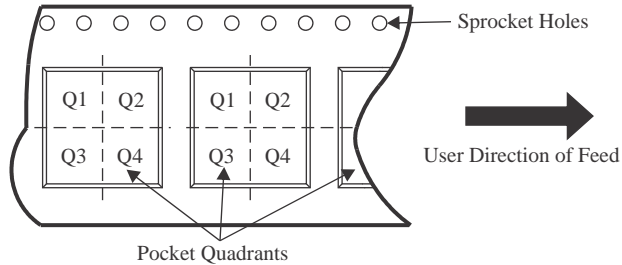
QUADRANT ASSIGNMENTS FOR PIN 1 ORIENTATION IN TAPE

*All dimensions are nominal

Device	Package Type	Package Drawing	Pins	SPQ	Reel Diameter (mm)	Reel Width W1 (mm)	A0 (mm)	B0 (mm)	K0 (mm)	P1 (mm)	W (mm)	Pin1 Quadrant
SN75160BDWR	SOIC	DW	20	2000	330.0	24.4	10.8	13.3	2.7	12.0	24.0	Q1

TAPE AND REEL BOX DIMENSIONS

*All dimensions are nominal

Device	Package Type	Package Drawing	Pins	SPQ	Length (mm)	Width (mm)	Height (mm)
SN75160BDWR	SOIC	DW	20	2000	367.0	367.0	45.0

TUBE

*All dimensions are nominal

Device	Package Name	Package Type	Pins	SPQ	L (mm)	W (mm)	T (μm)	B (mm)
SN75160BDW	DW	SOIC	20	25	506.98	12.7	4826	6.6
SN75160BDW	DW	SOIC	20	25	507	12.83	5080	6.6
SN75160BDWE4	DW	SOIC	20	25	507	12.83	5080	6.6
SN75160BDWE4	DW	SOIC	20	25	506.98	12.7	4826	6.6
SN75160BDWG4	DW	SOIC	20	25	507	12.83	5080	6.6
SN75160BDWG4	DW	SOIC	20	25	506.98	12.7	4826	6.6
SN75160BN	N	PDIP	20	20	506	13.97	11230	4.32

N (R-PDIP-T**)

PLASTIC DUAL-IN-LINE PACKAGE

16 PINS SHOWN



- NOTES:
- A. All linear dimensions are in inches (millimeters).
 - B. This drawing is subject to change without notice.
 - C Falls within JEDEC MS-001, except 18 and 20 pin minimum body length (Dim A).
 - D The 20 pin end lead shoulder width is a vendor option, either half or full width.

4040049/E 12/2002

DW0020A



PACKAGE OUTLINE

SOIC - 2.65 mm max height

SOIC



NOTES:

1. All linear dimensions are in millimeters. Dimensions in parenthesis are for reference only. Dimensioning and tolerancing per ASME Y14.5M.
2. This drawing is subject to change without notice.
3. This dimension does not include mold flash, protrusions, or gate burrs. Mold flash, protrusions, or gate burrs shall not exceed 0.15 mm per side.
4. This dimension does not include interlead flash. Interlead flash shall not exceed 0.43 mm per side.
5. Reference JEDEC registration MS-013.

EXAMPLE BOARD LAYOUT

DW0020A

SOIC - 2.65 mm max height

SOIC



LAND PATTERN EXAMPLE
SCALE:6X



SOLDER MASK DETAILS

4220724/A 05/2016

NOTES: (continued)

- 6. Publication IPC-7351 may have alternate designs.
- 7. Solder mask tolerances between and around signal pads can vary based on board fabrication site.

EXAMPLE STENCIL DESIGN

DW0020A

SOIC - 2.65 mm max height

SOIC



SOLDER PASTE EXAMPLE
BASED ON 0.125 mm THICK STENCIL
SCALE:6X

4220724/A 05/2016

NOTES: (continued)

8. Laser cutting apertures with trapezoidal walls and rounded corners may offer better paste release. IPC-7525 may have alternate design recommendations.
9. Board assembly site may have different recommendations for stencil design.

IMPORTANT NOTICE AND DISCLAIMER

TI PROVIDES TECHNICAL AND RELIABILITY DATA (INCLUDING DATA SHEETS), DESIGN RESOURCES (INCLUDING REFERENCE DESIGNS), APPLICATION OR OTHER DESIGN ADVICE, WEB TOOLS, SAFETY INFORMATION, AND OTHER RESOURCES "AS IS" AND WITH ALL FAULTS, AND DISCLAIMS ALL WARRANTIES, EXPRESS AND IMPLIED, INCLUDING WITHOUT LIMITATION ANY IMPLIED WARRANTIES OF MERCHANTABILITY, FITNESS FOR A PARTICULAR PURPOSE OR NON-INFRINGEMENT OF THIRD PARTY INTELLECTUAL PROPERTY RIGHTS.

These resources are intended for skilled developers designing with TI products. You are solely responsible for (1) selecting the appropriate TI products for your application, (2) designing, validating and testing your application, and (3) ensuring your application meets applicable standards, and any other safety, security, regulatory or other requirements.

These resources are subject to change without notice. TI grants you permission to use these resources only for development of an application that uses the TI products described in the resource. Other reproduction and display of these resources is prohibited. No license is granted to any other TI intellectual property right or to any third party intellectual property right. TI disclaims responsibility for, and you will fully indemnify TI and its representatives against, any claims, damages, costs, losses, and liabilities arising out of your use of these resources.

TI's products are provided subject to [TI's Terms of Sale](#) or other applicable terms available either on [ti.com](https://www.ti.com) or provided in conjunction with such TI products. TI's provision of these resources does not expand or otherwise alter TI's applicable warranties or warranty disclaimers for TI products.

TI objects to and rejects any additional or different terms you may have proposed.

Mailing Address: Texas Instruments, Post Office Box 655303, Dallas, Texas 75265
Copyright © 2024, Texas Instruments Incorporated

Looking for pricing, stock, or lifecycle information?

Click below to explore more details on WIN SOURCE:

 [View SN75160BDWR on WIN SOURCE](#)

 [Texas Instruments](#) Information

Optimize Your Supply Chain with WIN SOURCE Solutions

-  Global Sourcing Solution
-  Obsolete Management
-  Cost Control Management
-  Shortage Management
-  Alternative Solution
-  Excess Inventory Management