



THE DATASHEET OF SN74TVC3306DCUR



SN74TVC3306 Dual Voltage Clamp

1 Features

- Designed to Be Used in Voltage-Limiting Applications
- 3.5-Ω On-State Connection Between Ports A and B
- Flow-Through Pinout for Ease of Printed Circuit Board Trace Routing
- Direct Interface With GTL+ Levels
- Latch-Up Performance Exceeds 100 mA Per JESD 78, Class II
- ESD Protection Exceeds JESD 22
 - 2000-V Human-Body Model
 - 200-V Machine Model
 - 1000-V Charged-Device Model

2 Applications

- Voltage Level Translation
- Signal Switching
- Bus Isolation

4 Simplified Schematic

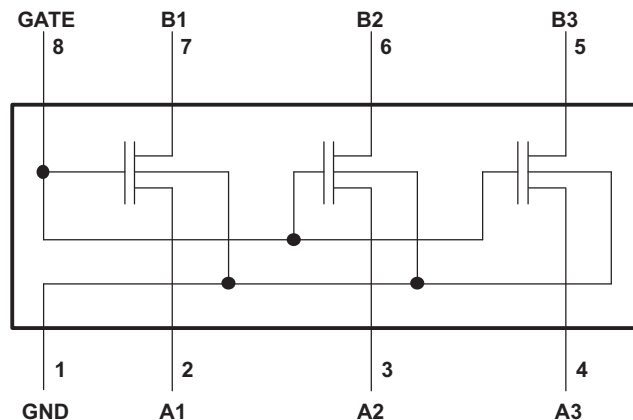

The SN74TVC3306 device has bidirectional capability across many voltage levels. The voltage levels documented in this data sheet are examples.

3 Description

The SN74TVC3306 device provides three parallel NMOS pass transistors with a common unbuffered gate. The low on-state resistance of the switch allows connections to be made with minimal propagation delay.

The device can be used as a dual switch, with the gates cascaded together to a reference transistor. The low-voltage side of each pass transistor is limited to a voltage set by the reference transistor. This is done to protect components with inputs that are sensitive to high-state voltage-level overshoots.

Device Information⁽¹⁾

PART NUMBER	PACKAGE	BODY SIZE (NOM)
SN74TVC3306	SM8 (8)	3.00 mm x 2.80 mm
	US8 (8)	2.30 mm x 2.00 mm

(1) For all available packages, see the orderable addendum at the end of the data sheet.



Table of Contents

1 Features	1	7.10 Typical Characteristics	6
2 Applications	1	8 Parameter Measurement Information	6
3 Description	1	9 Detailed Description	7
4 Simplified Schematic	1	9.1 Overview	7
5 Revision History	2	9.2 Functional Block Diagram	7
6 Pin Configuration and Functions	3	9.3 Feature Description	7
7 Specifications	4	9.4 Device Functional Modes	7
7.1 Absolute Maximum Ratings	4	10 Application and Implementation	8
7.2 ESD Ratings	4	10.1 Application Information	8
7.3 Recommended Operating Conditions	4	10.2 Typical Application	8
7.4 Thermal Information	4	11 Power Supply Recommendations	10
7.5 Electrical Characteristics	5	12 Layout	10
7.6 Switching Characteristics (AC, $V_{GATE} = 3.3\text{ V}$, Translating Down)	5	12.1 Layout Guidelines	10
7.7 Switching Characteristics (AC, $V_{GATE} = 2.5\text{ V}$, Translating Down)	5	12.2 Layout Example	10
7.8 Switching Characteristics (AC, $V_{GATE} = 3.3\text{ V}$, Translating Up)	5	13 Device and Documentation Support	10
7.9 Switching Characteristics (AC, $V_{GATE} = 2.5\text{ V}$, Translating Up)	5	13.1 Trademarks	10
		13.2 Electrostatic Discharge Caution	10
		13.3 Glossary	10
		14 Mechanical, Packaging, and Orderable Information	10

5 Revision History

Changes from Revision C (March 2002) to Revision D

Page

<ul style="list-style-type: none"> Added <i>Applications</i>, <i>Device Information</i> table, <i>Pin Functions</i> table, <i>Handling Ratings</i> table, <i>Thermal Information</i> table, <i>Typical Characteristics</i>, <i>Feature Description</i> section, <i>Device Functional Modes</i>, <i>Application and Implementation</i> section, <i>Power Supply Recommendations</i> section, <i>Layout</i> section, <i>Device and Documentation Support</i> section, and <i>Mechanical, Packaging, and Orderable Information</i> section. 	1
<ul style="list-style-type: none"> Deleted <i>Ordering Information</i> table. 	1
<ul style="list-style-type: none"> Changed the R_{ON} parameter in the <i>Electrical Characersitics</i> table. 	5

6 Pin Configuration and Functions

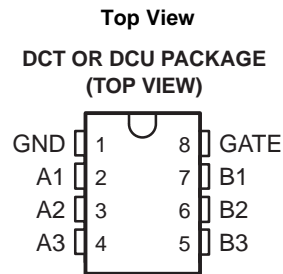

Pin Functions

PIN		TYPE	DESCRIPTION
NAME	NO.		
A1	2	I/O	I/O of gate 1
A2	3	I/O	I/O of gate 1
A3	4	I/O	I/O of gate 1
B1	5	I/O	I/O of gate 2
B2	6	I/O	I/O of gate 2
B3	7	I/O	I/O of gate 2
GATE	8	I	Gate pin. Set high to enable the switches. Connect to B1 (V_{BIAS}) for translation application.
GND	1	—	Ground

7 Specifications

7.1 Absolute Maximum Ratings⁽¹⁾

over operating free-air temperature range (unless otherwise noted)

		MIN	MAX	UNIT
V _I	Input voltage range ⁽²⁾	-0.5	7	V
V _{I/O}	Input/output voltage range ⁽²⁾	-0.5	7	V
Continuous channel current			128	mA
I _{IK}	Input clamp current	V _I < 0		-50 mA
T _{stg}	Storage temperature range	-65	150	°C

- (1) Stresses beyond those listed under *Absolute Maximum Ratings* may cause permanent damage to the device. These are stress ratings only, and functional operation of the device at these or any other conditions beyond those indicated under *Recommended Operating Conditions* is not implied. Exposure to absolute-maximum-rated conditions for extended periods may affect device reliability.
- (2) The input and input/output negative-voltage ratings may be exceeded if the input and input/output clamp-current ratings are observed.

7.2 ESD Ratings

		VALUE	UNIT
V _(ESD)	Electrostatic discharge	Human body model (HBM), per ANSI/ESDA/JEDEC JS-001, all pins ⁽¹⁾	2500
		Charged device model (CDM), per JEDEC specification JESD22-C101, all pins ⁽²⁾	2000

- (1) JEDEC document JEP155 states that 500-V HBM allows safe manufacturing with a standard ESD control process.
- (2) JEDEC document JEP157 states that 250-V CDM allows safe manufacturing with a standard ESD control process.

7.3 Recommended Operating Conditions

		MIN	MAX	UNIT
V _{I/O}	Input/output voltage	0	5	V
V _{GATE}	GATE voltage	0	5	V
I _{PASS}	Pass transistor current		64	mA
T _A	Operating free-air temperature	-40	85	°C

7.4 Thermal Information

THERMAL METRIC ⁽¹⁾	SN74TVC3306		UNIT	
	DCT	DCU		
	8 PINS	8 PINS		
R _{θJA}	Junction-to-ambient thermal resistance	220	227	°C/W

- (1) For more information about traditional and new thermal metrics, see the *IC Package Thermal Metrics* application report, [SPRA953](http://www.ti.com/lit/zip/spra953).

7.5 Electrical Characteristics

over recommended operating free-air temperature range (unless otherwise noted)

PARAMETER	TEST CONDITIONS		MIN	TYP ⁽¹⁾	MAX	UNIT
V_{IK}	$I_I = -18 \text{ mA}$,	$V_{GATE} = 0$			-1.2	V
I_{IH}	$V_I = 5 \text{ V}$,	$V_{GATE} = 0$			5	μA
$C_{i(GATE)}$	$V_I = 3 \text{ V}$ or 0			11		pF
$C_{io(off)}$	$V_O = 3 \text{ V}$ or 0,	$V_{GATE} = 0$		4	6	pF
$C_{io(on)}$	$V_O = 3 \text{ V}$ or 0,	$V_{GATE} = 3 \text{ V}$		10.5	12.5	pF
$R_{on}^{(2)}$	$V_I = 0$,	$I_O = 64 \text{ mA}$	$V_{GATE} = 4.5 \text{ V}$	3.5	5.5	Ω
			$V_{GATE} = 3 \text{ V}$	4.7	7	
			$V_{GATE} = 2.3 \text{ V}$	6.3	9.5	
	$V_I = 2.4 \text{ V}$,	$I_O = 15 \text{ mA}$	$V_{GATE} = 4.5 \text{ V}$	4.8	7.5	
	$V_I = 1.8 \text{ V}$,	$I_O = 15 \text{ mA}$	$V_{GATE} = 4.5 \text{ V}$	4.5	5	

(1) All typical values are at $T_A = 25^\circ\text{C}$.

(2) Measured by the voltage drop between the A and B terminals at the indicated current through the switch. On-state resistance is determined by the lowest voltage of the two (A or B) terminals.

7.6 Switching Characteristics (AC, $V_{GATE} = 3.3 \text{ V}$, Translating Down)

over recommended operating free-air temperature range, $V_{GATE} = 3.3 \text{ V}$, $V_{IH} = 3.3 \text{ V}$, $V_{IL} = 0$, and $V_M = 1.15 \text{ V}$ (unless otherwise noted) (see [Figure 2](#))

PARAMETER	FROM (INPUT)	TO (OUTPUT)	$C_L = 50 \text{ pF}$		$C_L = 30 \text{ pF}$		$C_L = 15 \text{ pF}$		UNIT
			MIN	MAX	MIN	MAX	MIN	MAX	
t_{PLH}	A or B	B or A	0	0.8	0	0.6	0	0.3	ns
t_{PHL}			0	1.2	0	1	0	0.5	

7.7 Switching Characteristics (AC, $V_{GATE} = 2.5 \text{ V}$, Translating Down)

over recommended operating free-air temperature range, $V_{GATE} = 2.5 \text{ V}$, $V_{IH} = 2.5 \text{ V}$, $V_{IL} = 0$, and $V_M = 0.75 \text{ V}$ (unless otherwise noted) (see [Figure 2](#))

PARAMETER	FROM (INPUT)	TO (OUTPUT)	$C_L = 50 \text{ pF}$		$C_L = 30 \text{ pF}$		$C_L = 15 \text{ pF}$		UNIT
			MIN	MAX	MIN	MAX	MIN	MAX	
t_{PLH}	A or B	B or A	0	1	0	0.7	0	0.4	ns
t_{PHL}			0	1.3	0	1	0	0.6	

7.8 Switching Characteristics (AC, $V_{GATE} = 3.3 \text{ V}$, Translating Up)

over recommended operating free-air temperature range, $V_{GATE} = 3.3 \text{ V}$, $V_{IH} = 2.3 \text{ V}$, $V_{IL} = 0$, $V_T = 3.3 \text{ V}$, $V_M = 1.15 \text{ V}$, and $R_L = 300 \Omega$ (unless otherwise noted) (see [Figure 2](#))

PARAMETER	FROM (INPUT)	TO (OUTPUT)	$C_L = 50 \text{ pF}$		$C_L = 30 \text{ pF}$		$C_L = 15 \text{ pF}$		UNIT
			MIN	MAX	MIN	MAX	MIN	MAX	
t_{PLH}	A or B	B or A	0	0.9	0	0.6	0	0.4	ns
t_{PHL}			0	1.4	0	1.1	0	0.7	

7.9 Switching Characteristics (AC, $V_{GATE} = 2.5 \text{ V}$, Translating Up)

over recommended operating free-air temperature range, $V_{GATE} = 2.5 \text{ V}$, $V_{IH} = 1.5 \text{ V}$, $V_{IL} = 0$, $V_T = 2.5 \text{ V}$, $V_M = 0.75 \text{ V}$, and $R_L = 300 \Omega$ (unless otherwise noted) (see [Figure 2](#))

PARAMETER	FROM (INPUT)	TO (OUTPUT)	$C_L = 50 \text{ pF}$		$C_L = 30 \text{ pF}$		$C_L = 15 \text{ pF}$		UNIT
			MIN	MAX	MIN	MAX	MIN	MAX	
t_{PLH}	A or B	B or A	0	1	0	0.6	0	0.4	ns
t_{PHL}			0	1.3	0	1.3	0	0.8	

7.10 Typical Characteristics

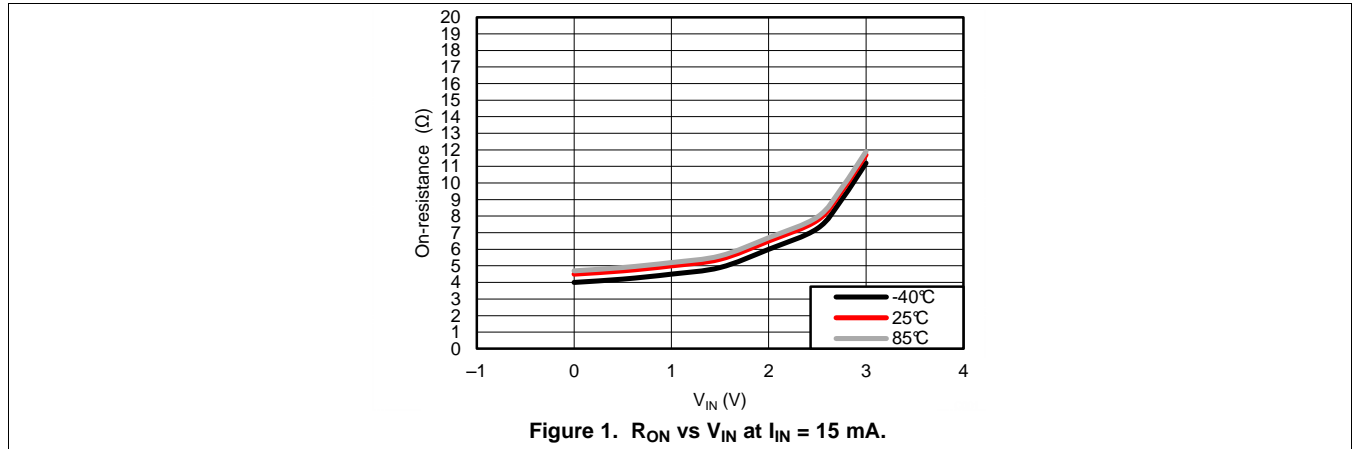

8 Parameter Measurement Information

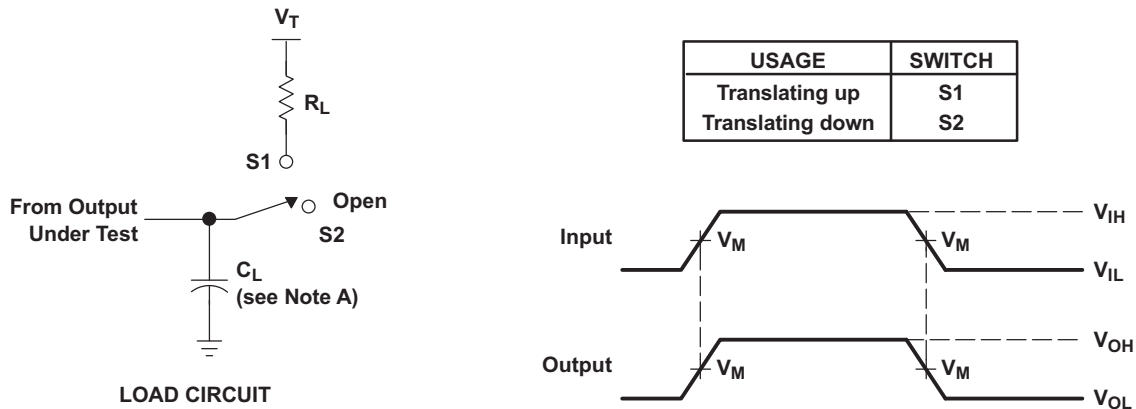

- NOTES: A. C_L includes probe and jig capacitance.
 B. All input pulses are supplied by generators having the following characteristics: $PRR \leq 10$ MHz, $Z_O = 50 \Omega$, $t_r \leq 2$ ns, $t_f \leq 2$ ns.
 C. The outputs are measured one at a time, with one transition per measurement.

Figure 2. Load Circuit for Outputs

9 Detailed Description

9.1 Overview

The SN74TVC3306 device provides three parallel NMOS pass transistors with a common unbuffered gate. The low on-state resistance of the switch allows connections to be made with minimal propagation delay.

The device can be used as a dual switch, with the gates cascaded together to a reference transistor. The low-voltage side of each pass transistor is limited to a voltage set by the reference transistor. This is done to protect components with inputs that are sensitive to high-state voltage-level overshoots.

9.2 Functional Block Diagram

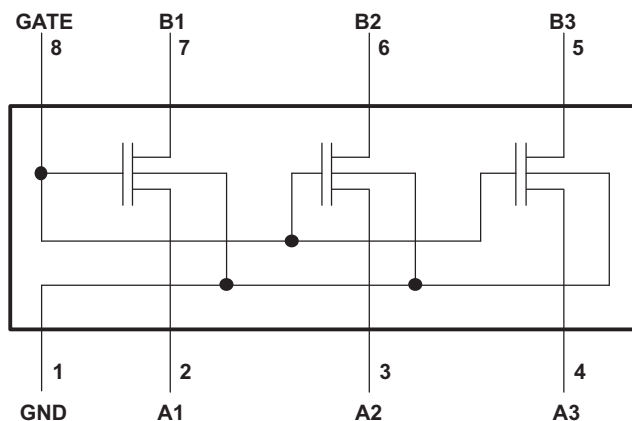

The SN74TVC3306 device has bidirectional capability across many voltage levels. The voltage levels documented in this data sheet are examples.

9.3 Feature Description

9.3.1 Voltage Clamping

The internal NMOS transistors allow the SN74TVC3306 device to act as a voltage clamp and be configured as a voltage level translator. See [Application and Implementation](#).

9.4 Device Functional Modes

9.4.1 Voltage Clamping

Whenever the signal on the inputs on the side with V_{REF} goes higher than V_{REF} , the voltage clamps on the opposite side to the value of V_{DPU} due to the pullup resistors. In this case, the voltage is translating up. See [Application and Implementation](#).

9.4.2 Voltage Passing

Whenever the signal on the inputs on the V_{REF} side is lower than V_{REF} , the signal will pass to the other side as intended. In this case, the low pulse is staying low (no translation). See [Application and Implementation](#).

10 Application and Implementation

NOTE

Information in the following applications sections is not part of the TI component specification, and TI does not warrant its accuracy or completeness. TI's customers are responsible for determining suitability of components for their purposes. Customers should validate and test their design implementation to confirm system functionality.

10.1 Application Information

Because of the voltage-clamping mechanism, the SN74TVC3306 device performs best as a level translator for signals that have sharp edges (as opposed to analog audio signals).

10.2 Typical Application

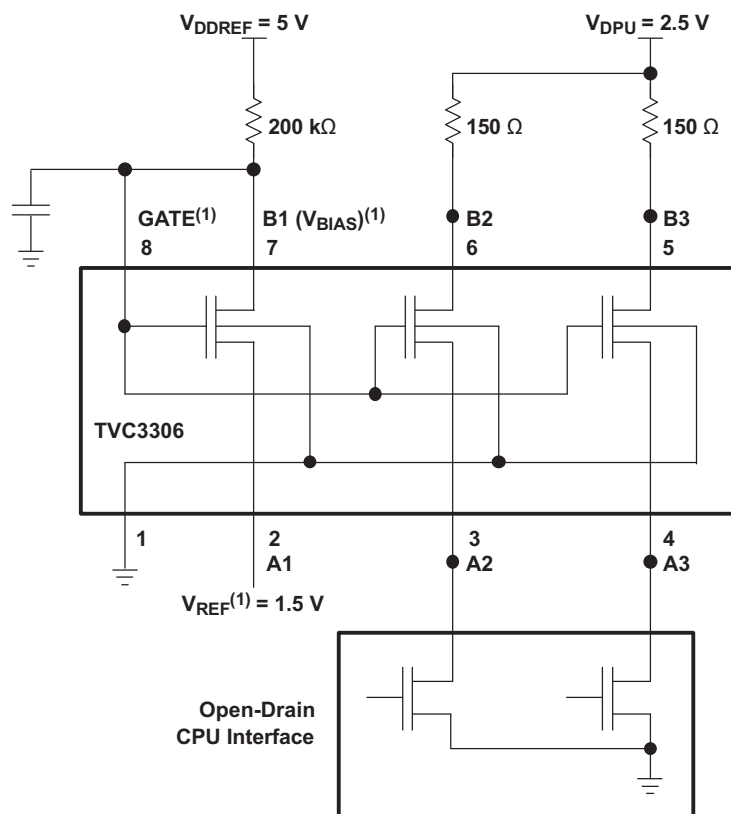

V_{REF} and V_{BIAS} can be applied to any one of the pass transistors. GATE must be connected externally to V_{BIAS} .

Figure 3. Typical Application Circuit

Typical Application (continued)

10.2.1 Design Requirements

10.2.1.1 Application Operating Conditions

Application Operating Conditions (See [Figure 3](#))

		MIN	TYP ⁽¹⁾	MAX	UNIT
V _{BIAS}	BIAS voltage	V _{REF} + 0.6	2.1	5	V
V _{GATE}	GATE voltage	V _{REF} + 0.6	2.1	5	V
V _{REF}	Reference voltage	0	1.5	4.4	V
V _{DPU}	Drain pullup voltage	2.36	2.5	2.64	V
I _{PASS}	Pass-transistor current		14		mA
I _{REF}	Reference-transistor current		5		μA
T _A	Operating free-air temperature	-40		85	°C

(1) All typical values are at T_A = 25°C.

10.2.2 Detailed Design Procedure

For the clamping configuration, the common GATE input must be connected to one side (An or Bn) of any one of the pass transistors, making that the V_{BIAS} connection of the reference transistor and the opposite side (Bn or An) the V_{REF} connection. When V_{BIAS} is connected through a 200-kΩ resistor to a 3-V to 5.5-V V_{CC} supply and V_{REF} is set to 0 V to V_{CC} – 0.6 V, the output of each switch has a maximum clamp voltage equal to V_{REF}. A filter capacitor on V_{BIAS} is recommended.

10.2.3 Application Curves

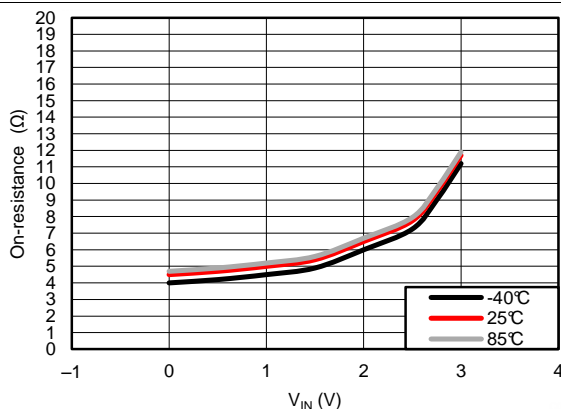

Figure 4. On-resistance vs VIN (A to B, 15 mA current)

11 Power Supply Recommendations

A 200-kΩ resistor is recommended from the input to V_{CC} when the device is being used as a voltage clamp. A filter capacitor is recommended on B1 as well.

12 Layout

12.1 Layout Guidelines

If used, the filter capacitor should be placed as close to the input of the device as possible.

12.2 Layout Example

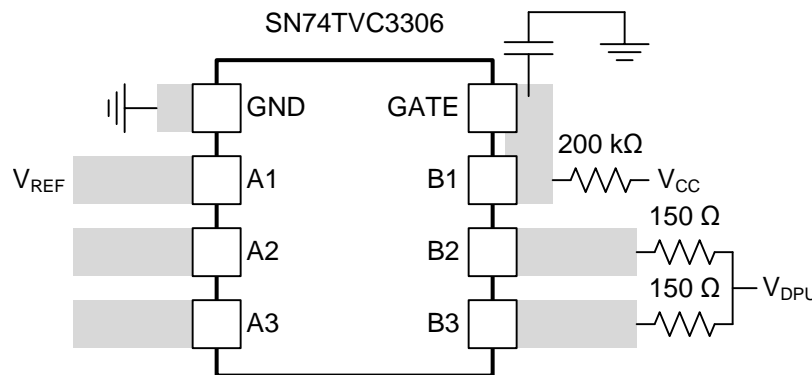

Figure 5. Layout example for voltage-clamp configuration

13 Device and Documentation Support

13.1 Trademarks

All trademarks are the property of their respective owners.

13.2 Electrostatic Discharge Caution



These devices have limited built-in ESD protection. The leads should be shorted together or the device placed in conductive foam during storage or handling to prevent electrostatic damage to the MOS gates.

13.3 Glossary

[SLYZ022](#) — TI Glossary.

This glossary lists and explains terms, acronyms, and definitions.

14 Mechanical, Packaging, and Orderable Information

The following pages include mechanical, packaging, and orderable information. This information is the most current data available for the designated devices. This data is subject to change without notice and revision of this document. For browser-based versions of this data sheet, refer to the left-hand navigation.

PACKAGING INFORMATION

Orderable Device	Status (1)	Package Type	Package Drawing	Pins	Package Qty	Eco Plan (2)	Lead/Ball Finish (6)	MSL Peak Temp (3)	Op Temp (°C)	Device Marking (4/5)	Samples
SN74TVC3306DCTR	ACTIVE	SM8	DCT	8	3000	Green (RoHS & no Sb/Br)	CU NIPDAU	Level-1-260C-UNLIM	-40 to 85	FA6 (S, Y)	Samples
SN74TVC3306DCTRE4	ACTIVE	SM8	DCT	8	3000	Green (RoHS & no Sb/Br)	CU NIPDAU	Level-1-260C-UNLIM	-40 to 85	FA6 (S, Y)	Samples
SN74TVC3306DCUR	ACTIVE	VSSOP	DCU	8	3000	Green (RoHS & no Sb/Br)	CU NIPDAU CU SN	Level-1-260C-UNLIM	-40 to 85	(FA6P, FA6S)	Samples
SN74TVC3306DCURG4	ACTIVE	VSSOP	DCU	8	3000	Green (RoHS & no Sb/Br)	CU NIPDAU	Level-1-260C-UNLIM	-40 to 85	FA6S	Samples

(1) The marketing status values are defined as follows:

ACTIVE: Product device recommended for new designs.

LIFEBUY: TI has announced that the device will be discontinued, and a lifetime-buy period is in effect.

NRND: Not recommended for new designs. Device is in production to support existing customers, but TI does not recommend using this part in a new design.

PREVIEW: Device has been announced but is not in production. Samples may or may not be available.

OBSOLETE: TI has discontinued the production of the device.

(2) **RoHS:** TI defines "RoHS" to mean semiconductor products that are compliant with the current EU RoHS requirements for all 10 RoHS substances, including the requirement that RoHS substance do not exceed 0.1% by weight in homogeneous materials. Where designed to be soldered at high temperatures, "RoHS" products are suitable for use in specified lead-free processes. TI may reference these types of products as "Pb-Free".

RoHS Exempt: TI defines "RoHS Exempt" to mean products that contain lead but are compliant with EU RoHS pursuant to a specific EU RoHS exemption.

Green: TI defines "Green" to mean the content of Chlorine (Cl) and Bromine (Br) based flame retardants meet JS709B low halogen requirements of <=1000ppm threshold. Antimony trioxide based flame retardants must also meet the <=1000ppm threshold requirement.

(3) MSL, Peak Temp. - The Moisture Sensitivity Level rating according to the JEDEC industry standard classifications, and peak solder temperature.

(4) There may be additional marking, which relates to the logo, the lot trace code information, or the environmental category on the device.

(5) Multiple Device Markings will be inside parentheses. Only one Device Marking contained in parentheses and separated by a "-" will appear on a device. If a line is indented then it is a continuation of the previous line and the two combined represent the entire Device Marking for that device.

(6) Lead/Ball Finish - Orderable Devices may have multiple material finish options. Finish options are separated by a vertical ruled line. Lead/Ball Finish values may wrap to two lines if the finish value exceeds the maximum column width.

Important Information and Disclaimer:The information provided on this page represents TI's knowledge and belief as of the date that it is provided. TI bases its knowledge and belief on information provided by third parties, and makes no representation or warranty as to the accuracy of such information. Efforts are underway to better integrate information from third parties. TI has taken and

continues to take reasonable steps to provide representative and accurate information but may not have conducted destructive testing or chemical analysis on incoming materials and chemicals. TI and TI suppliers consider certain information to be proprietary, and thus CAS numbers and other limited information may not be available for release.

In no event shall TI's liability arising out of such information exceed the total purchase price of the TI part(s) at issue in this document sold by TI to Customer on an annual basis.

TAPE AND REEL INFORMATION



QUADRANT ASSIGNMENTS FOR PIN 1 ORIENTATION IN TAPE



*All dimensions are nominal

Device	Package Type	Package Drawing	Pins	SPQ	Reel Diameter (mm)	Reel Width W1 (mm)	A0 (mm)	B0 (mm)	K0 (mm)	P1 (mm)	W (mm)	Pin1 Quadrant
SN74TVC3306DCTR	SM8	DCT	8	3000	180.0	13.0	3.35	4.5	1.55	4.0	12.0	Q3
SN74TVC3306DCUR	VSSOP	DCU	8	3000	180.0	8.4	2.25	3.35	1.05	4.0	8.0	Q3
SN74TVC3306DCURG4	VSSOP	DCU	8	3000	180.0	8.4	2.25	3.35	1.05	4.0	8.0	Q3

TAPE AND REEL BOX DIMENSIONS

*All dimensions are nominal

Device	Package Type	Package Drawing	Pins	SPQ	Length (mm)	Width (mm)	Height (mm)
SN74TVC3306DCTR	SM8	DCT	8	3000	182.0	182.0	20.0
SN74TVC3306DCUR	VSSOP	DCU	8	3000	202.0	201.0	28.0
SN74TVC3306DCURG4	VSSOP	DCU	8	3000	202.0	201.0	28.0

DCT (R-PDSO-G8)

PLASTIC SMALL OUTLINE

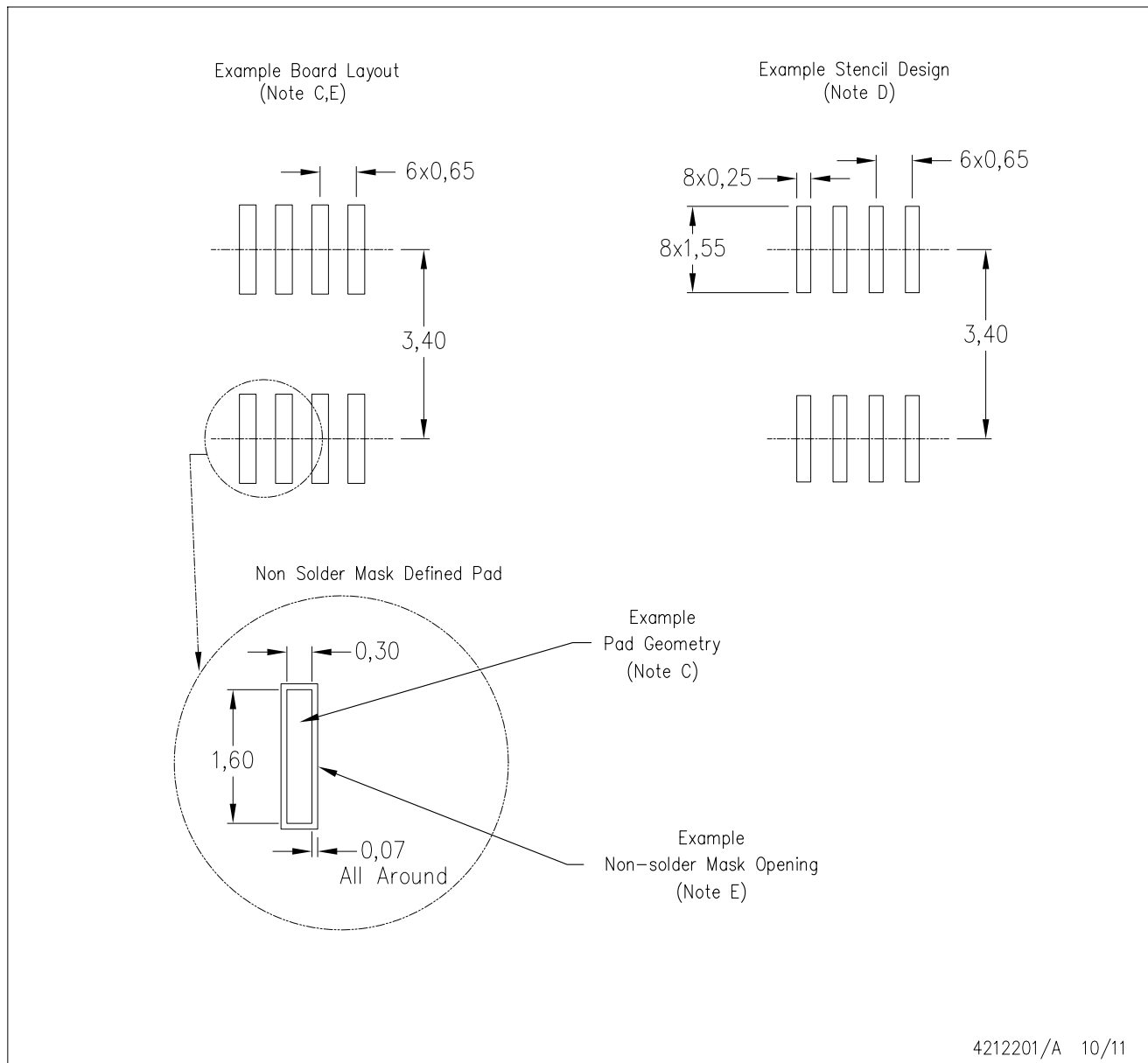

- NOTES:
- A. All linear dimensions are in millimeters.
 - B. This drawing is subject to change without notice.
 - C. Publication IPC-7351 is recommended for alternate designs.
 - D. Laser cutting apertures with trapezoidal walls and also rounding corners will offer better paste release. Customers should contact their board assembly site for stencil design recommendations. Refer to IPC-7525.
 - E. Customers should contact their board fabrication site for solder mask tolerances between and around signal pads.

DCU (S-PDSO-G8)

PLASTIC SMALL OUTLINE PACKAGE (DIE DOWN)

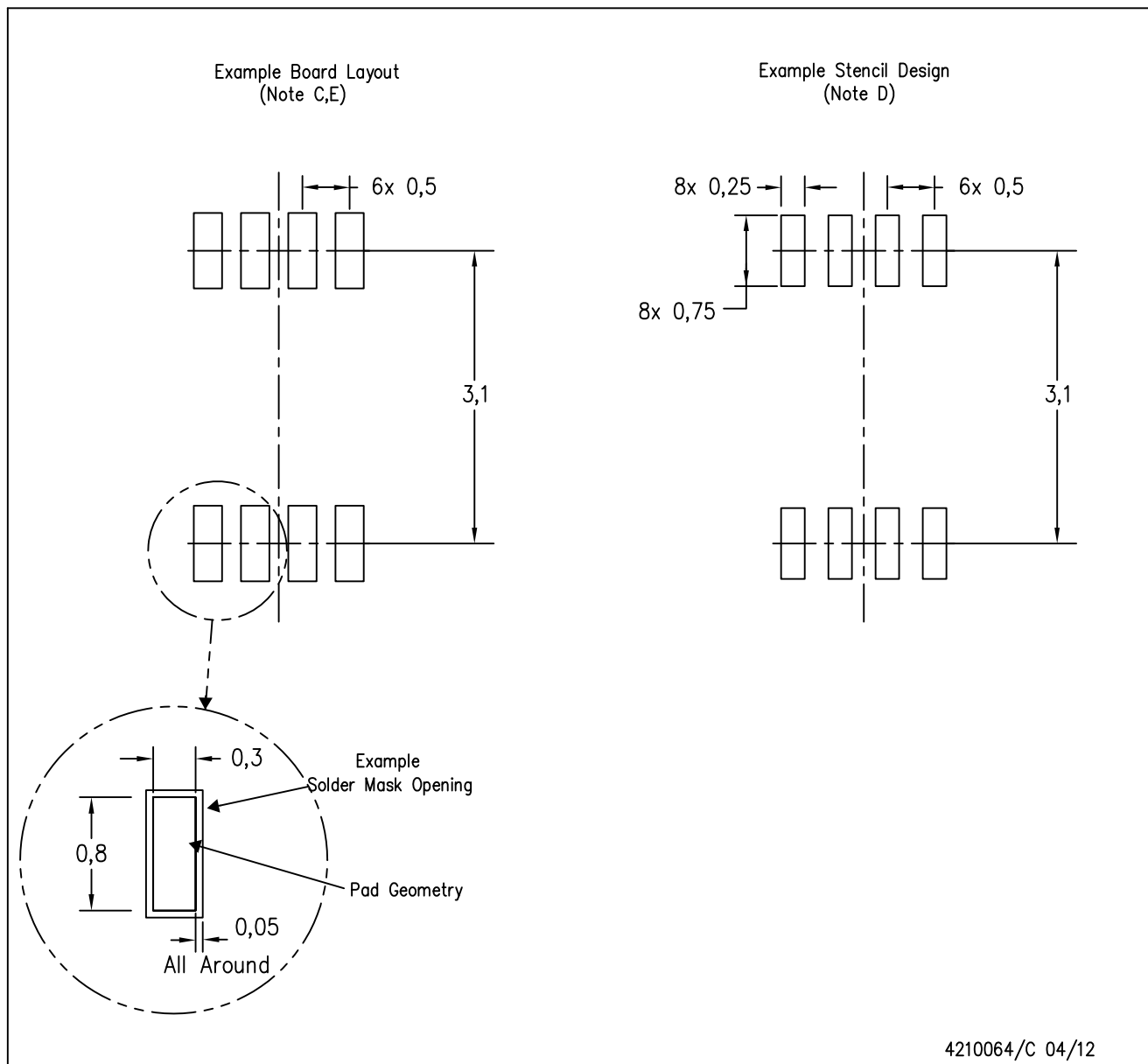

- NOTES:
- A. All linear dimensions are in millimeters.
 - B. This drawing is subject to change without notice.
 - C. Publication IPC-7351 is recommended for alternate designs.
 - D. Laser cutting apertures with trapezoidal walls and also rounding corners will offer better paste release. Customers should contact their board assembly site for stencil design recommendations. Refer to IPC-7525 for other stencil recommendations.
 - E. Customers should contact their board fabrication site for solder mask tolerances between and around signal pads.

IMPORTANT NOTICE AND DISCLAIMER

TI PROVIDES TECHNICAL AND RELIABILITY DATA (INCLUDING DATASHEETS), DESIGN RESOURCES (INCLUDING REFERENCE DESIGNS), APPLICATION OR OTHER DESIGN ADVICE, WEB TOOLS, SAFETY INFORMATION, AND OTHER RESOURCES "AS IS" AND WITH ALL FAULTS, AND DISCLAIMS ALL WARRANTIES, EXPRESS AND IMPLIED, INCLUDING WITHOUT LIMITATION ANY IMPLIED WARRANTIES OF MERCHANTABILITY, FITNESS FOR A PARTICULAR PURPOSE OR NON-INFRINGEMENT OF THIRD PARTY INTELLECTUAL PROPERTY RIGHTS.

These resources are intended for skilled developers designing with TI products. You are solely responsible for (1) selecting the appropriate TI products for your application, (2) designing, validating and testing your application, and (3) ensuring your application meets applicable standards, and any other safety, security, or other requirements. These resources are subject to change without notice. TI grants you permission to use these resources only for development of an application that uses the TI products described in the resource. Other reproduction and display of these resources is prohibited. No license is granted to any other TI intellectual property right or to any third party intellectual property right. TI disclaims responsibility for, and you will fully indemnify TI and its representatives against, any claims, damages, costs, losses, and liabilities arising out of your use of these resources.

TI's products are provided subject to TI's Terms of Sale (www.ti.com/legal/termsofsale.html) or other applicable terms available either on ti.com or provided in conjunction with such TI products. TI's provision of these resources does not expand or otherwise alter TI's applicable warranties or warranty disclaimers for TI products.

Mailing Address: Texas Instruments, Post Office Box 655303, Dallas, Texas 75265
Copyright © 2019, Texas Instruments Incorporated

Looking for pricing, stock, or lifecycle information?

Click below to explore more details on WIN SOURCE:

 [View SN74TVC3306DCUR on WIN SOURCE](#)

 [Texas Instruments](#) Information

Optimize Your Supply Chain with WIN SOURCE Solutions

-  Global Sourcing Solution
-  Obsolete Management
-  Cost Control Management
-  Shortage Management
-  Alternative Solution
-  Excess Inventory Management