



**THE DATASHEET OF  
SN74TVC16222ADGVR**





# SN74TVC16222A

## 22-BIT VOLTAGE CLAMP

SCDS087G – APRIL 1999 – REVISED APRIL 2005

### simplified schematic

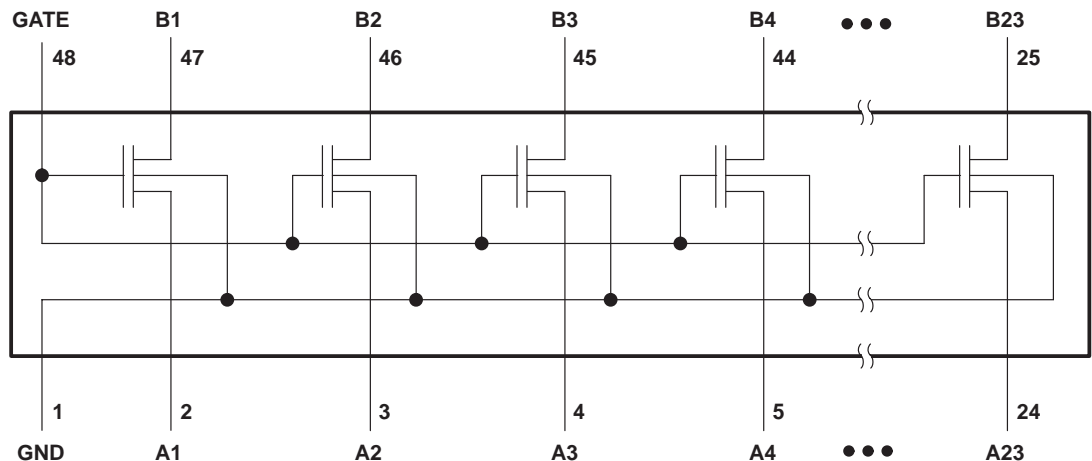

### absolute maximum ratings over operating free-air temperature range (unless otherwise noted)†

Input voltage range, $V_I$ (see Note 1)	.....	-0.5 V to 7 V
Input/output voltage range, $V_{I/O}$ (see Note 1)	.....	-0.5 V to 7 V
Continuous channel current	.....	128 mA
Input clamp current, $I_{IK}$ ( $V_I < 0$ )	.....	-50 mA
Package thermal impedance, $\theta_{JA}$ (see Note 2):		
DGG package	.....	70°C/W
DGV package	.....	58°C/W
DL package	.....	63°C/W
Storage temperature range, $T_{stg}$	.....	-65°C to 150°C

† Stresses beyond those listed under “absolute maximum ratings” may cause permanent damage to the device. These are stress ratings only, and functional operation of the device at these or any other conditions beyond those indicated under “recommended operating conditions” is not implied. Exposure to absolute-maximum-rated conditions for extended periods may affect device reliability.

- NOTES: 1. The input and input/output negative-voltage ratings may be exceeded if the input and input/output clamp-current ratings are observed.  
 2. The package thermal impedance is calculated in accordance with JESD 51-7.

### recommended operating conditions

		MIN	TYP	MAX	UNIT
$V_{I/O}$	Input/output voltage	0		5.5	V
$V_{GATE}$	GATE voltage	0		5.5	V
$I_{PASS}$	Pass-transistor current		20	64	mA
$T_A$	Operating free-air temperature	-40		85	°C

### application operating conditions (see Figure 3)

		MIN	TYP	MAX	UNIT
$V_{BIAS}$	BIAS voltage	$V_{REF} + 0.6$	2.1	5	V
$V_{GATE}$	GATE voltage	$V_{REF} + 0.6$	2.1	5	V
$V_{REF}$	Reference voltage	0	1.5	4.4	V
$V_{DPU}$	Drain pullup voltage	2.36	2.5	2.64	V
$I_{PASS}$	Pass-transistor current		14	20	mA
$I_{REF}$	Reference-transistor current		5		μA
$T_A$	Operating free-air temperature	-40		85	°C



POST OFFICE BOX 655303 • DALLAS, TEXAS 75265

**electrical characteristics over recommended operating free-air temperature range (unless otherwise noted)**

PARAMETER	TEST CONDITIONS			MIN	TYP†	MAX	UNIT
$V_{IK}$	$V_{BIAS} = 0,$	$I_I = -18 \text{ mA}$				-1.2	V
$V_{OL}$	$I_{REF} = 5 \mu\text{A},$ $V_{DPU} = 2.625 \text{ V},$	$V_{REF} = 1.365 \text{ V},$ $R_{DPU} = 150 \Omega$	$V_S = 0.175 \text{ V},$ See Figure 2			350	mV
$C_{i(GATE)}$	$V_I = 3 \text{ V or } 0$				73		pF
$C_{io(off)}$	$V_O = 3 \text{ V or } 0$				4	12	pF
$C_{io(on)}$	$V_O = 3 \text{ V or } 0$				12	25	pF
$r_{on}^\ddagger$	$I_{REF} = 5 \mu\text{A},$ $V_{DPU} = 2.625 \text{ V},$	$V_{REF} = 1.365 \text{ V},$ $R_{DPU} = 150 \Omega$	$V_S = 0.175 \text{ V},$ See Figure 2			12.5	$\Omega$

† All typical values are at  $T_A = 25^\circ\text{C}$ .

‡ Measured by the voltage drop between the A and B terminals at the indicated current through the switch. On-state resistance is determined by the lower voltage of the two (A or B) terminals.

**electrical characteristics from  $-40^\circ\text{C}$  to  $75^\circ\text{C}$**

PARAMETER	TEST CONDITIONS			MIN	MAX	UNIT
$r_{on}^\ddagger$	$I_{REF} = 5 \mu\text{A},$ $V_{DPU} = 2.625 \text{ V},$	$V_{REF} = 1.552 \text{ V},$ $R_{DPU} = 150 \Omega$	$V_S = 0.175 \text{ V},$ See Figure 2		10	$\Omega$

‡ Measured by the voltage drop between the A and B terminals at the indicated current through the switch. On-state resistance is determined by the lower voltage of the two (A or B) terminals.

**switching characteristics over recommended operating free-air temperature range,  $V_{DPU} = 2.36 \text{ V to } 2.64 \text{ V}$  (unless otherwise noted) (see Figure 1)**

PARAMETER	FROM (INPUT)	TO (OUTPUT)	MIN	MAX	UNIT
$t_{PLH}$	A or B	B or A	0	4	ns
$t_{PHL}$			0	4	

# SN74TVC16222A 22-BIT VOLTAGE CLAMP

SCDS087G – APRIL 1999 – REVISED APRIL 2005

## PARAMETER MEASUREMENT INFORMATION

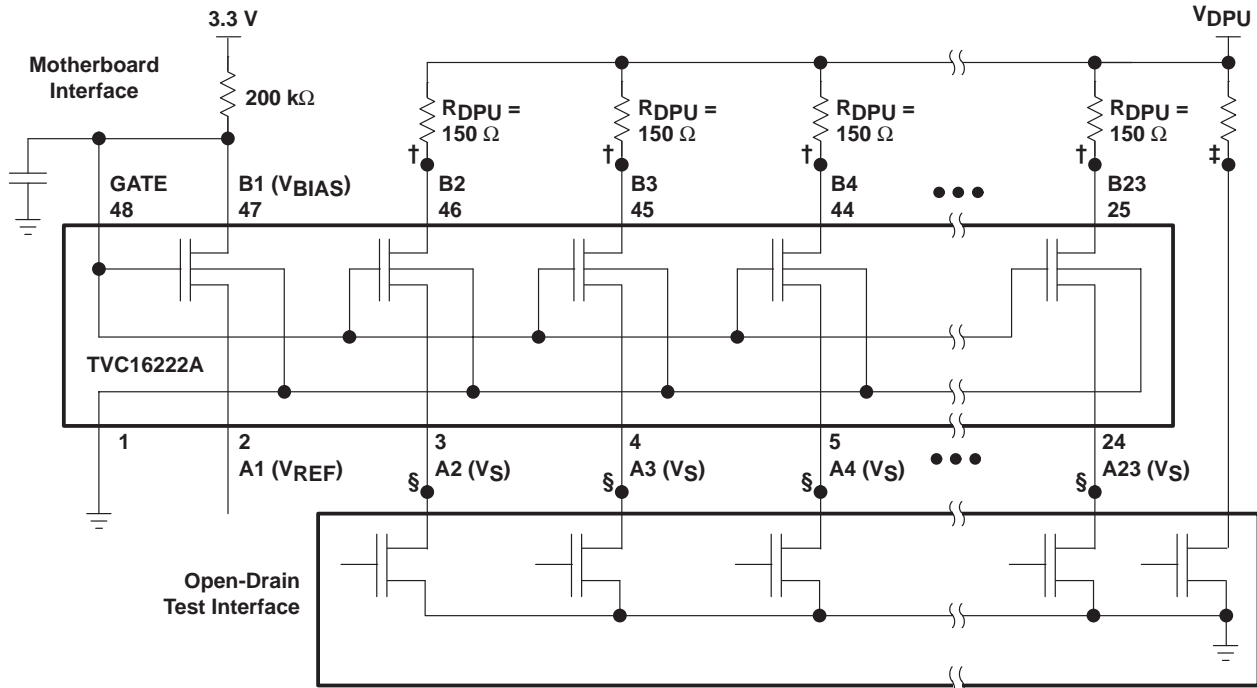

TESTER CALIBRATION SETUP (see Note C)

DEFINITION	SYMBOL
Output tested	†
Output reference	‡
Input tested	§

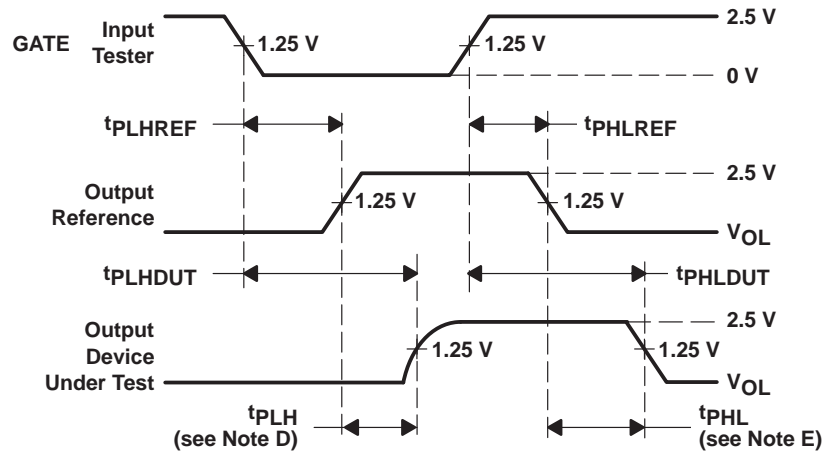

VOLTAGE WAVEFORMS  
PROPAGATION DELAY TIMES

- NOTES:
- A. All input pulses are supplied by generators having the following characteristics:  $PRR \leq 10$  MHz,  $Z_O = 50 \Omega$ ,  $t_r \leq 2$  ns,  $t_f \leq 2$  ns.
  - B. The outputs are measured one at a time, with one transition per measurement.
  - C. Test procedure:  $t_{PLHREF}$  and  $t_{PHLREF}$  are obtained by measuring the propagation delay of a reference measuring point.  $t_{PLHDUT}$  and  $t_{PHLDUT}$  are obtained by measuring the propagation delay of the device under test.
  - D.  $t_{PLH} = t_{PLHDUT} - t_{PLHREF}$
  - E.  $t_{PHL} = t_{PHLDUT} - t_{PHLREF}$

Figure 1. Tester Calibration Setup and Voltage Waveforms

---

**APPLICATION INFORMATION**

**TVC background information**

In personal computer (PC) architecture, there are industry-accepted bus standards. These standards define, among other things, the I/O voltage levels at which the bus communicates. Examples include the GTL+ host bus, the AGP graphics port, and the PCI local bus. In new designs, the system components must communicate with existing bus infrastructure. Providing an evolutionary upgrade path is important in the design of PC architecture, but the existing bus standards must be preserved.

To achieve the ever-present need for smaller, faster, lighter devices that draw less power, yet have faster performance, most new high-performance digital integrated circuits are designed and produced with advanced submicron semiconductor process technologies. These devices have thin gate-oxide or short channel lengths and very low absolute-maximum voltages that can be tolerated at the inputs/outputs (I/Os) without causing damage. In many cases, the I/Os of these devices are not tolerant of the high-state voltage levels on the preexisting buses with which they must communicate. Therefore, it became necessary to protect the I/Os of devices by limiting the I/O voltages.

The Texas Instruments (TI™) translation voltage-clamp (TVC) family is designed specifically for protecting sensitive I/Os (see Figure 2). The information in this data sheet describes the I/O-protection application of the TVC family and should enable the design engineer to successfully implement an I/O-protection circuit utilizing the TI TVC solution.

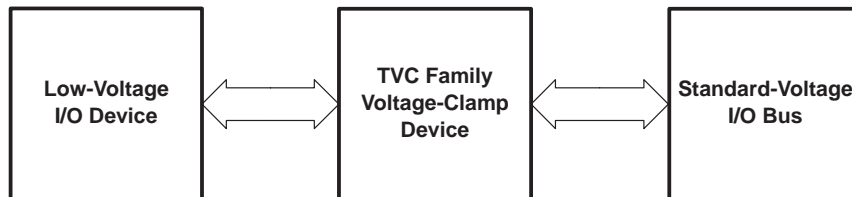

**Figure 2. Thin Gate-Oxide Protection Application**

# SN74TVC16222A 22-BIT VOLTAGE CLAMP

SCDS087G – APRIL 1999 – REVISED APRIL 2005

## APPLICATION INFORMATION

### TVC voltage-limiting application

For the voltage-limiting configuration, the common GATE input must be connected to one side (A or B) of any one of the transistors (see Figure 3). This connection determines the  $V_{BIAS}$  input of the reference transistor. The  $V_{BIAS}$  input is connected through a pullup resistor (typically 200 k $\Omega$ ) to the  $V_{DD}$  supply. A filter capacitor on  $V_{BIAS}$  is recommended. The opposite side of the reference transistor is used as the reference voltage ( $V_{REF}$ ) connection. The  $V_{REF}$  input must be less than  $V_{DDREF} - 1$  V to bias the reference transistor into conduction. The reference transistor regulates the gate voltage ( $V_{GATE}$ ) of all the pass transistors.  $V_{GATE}$  is determined by the characteristic gate-to-source voltage difference ( $V_{GS}$ ) because  $V_{GATE} = V_{REF} + V_{GS}$ . The low-voltage side of the pass transistors has a high-level voltage limited to a maximum of  $V_{GATE} - V_{GS}$ , or  $V_{REF}$ .

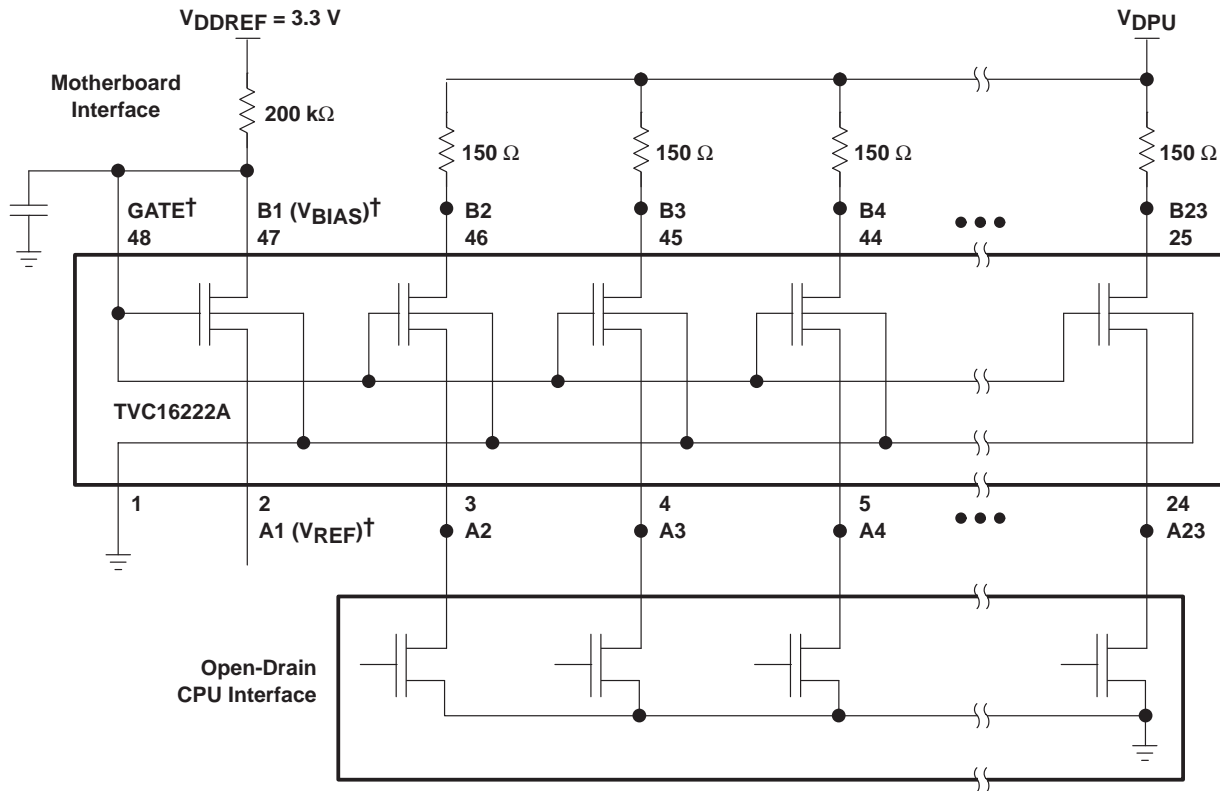

†  $V_{REF}$  and  $V_{BIAS}$  can be applied to any one of the pass transistors. GATE must be connected externally to  $V_{BIAS}$ .

Figure 3. Typical Application Circuit

APPLICATION INFORMATION

electrical characteristics

The electrical characteristics of the NMOS transistors used in the TVC devices are illustrated by TI SPICE simulations. Figure 4 shows the test configuration for the TI SPICE simulations. The results, shown in Figures 5 and 6, show the current through a pass transistor versus the voltage at the source for different reference voltages. The plots of the dc characteristics clearly reveal that the device clamps at the desired reference voltage for the varying device environments.

Figure 5 shows the V-I characteristics with low reference voltages and a reference-transistor drain-supply voltage of 3.3 V. To further investigate the spread of the V-I characteristic curves,  $V_{REF}$  was held at 2.5 V and  $I_{REF}$  was increased by raising  $V_{DDREF}$  (see Figure 6). The result was a tighter grouping of the V-I curves.

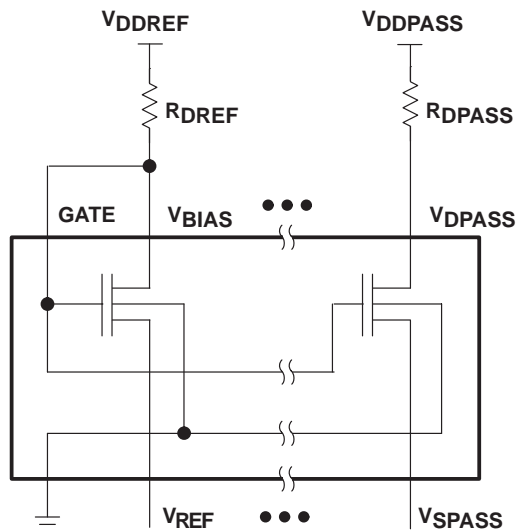

Figure 4. TI SPICE-Simulation Schematic and Voltage-Node Names

# SN74TVC16222A 22-BIT VOLTAGE CLAMP

SCDS087G – APRIL 1999 – REVISED APRIL 2005

## APPLICATION INFORMATION

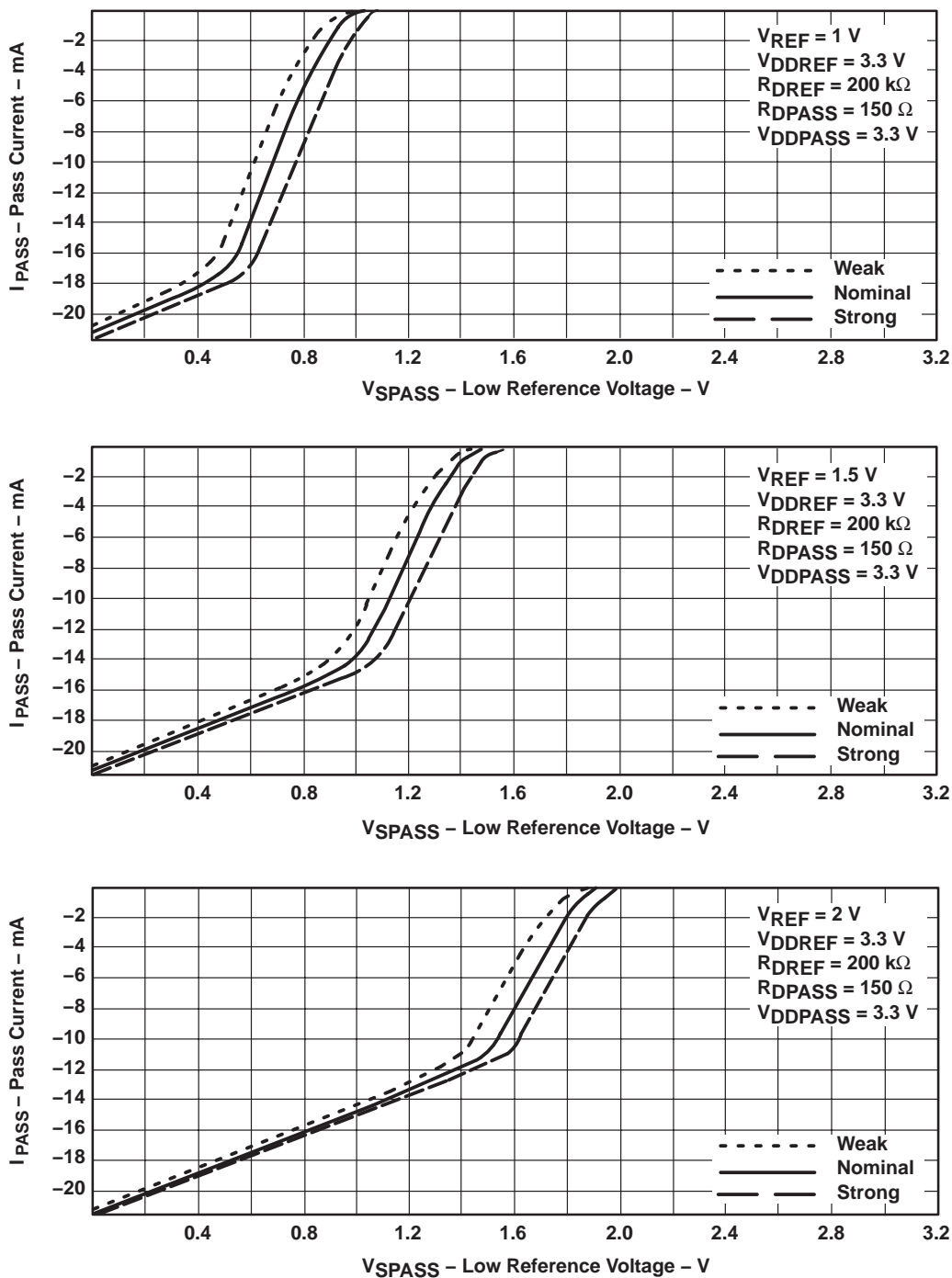

Figure 5. V-I Electrical Characteristics at Low  $V_{REF}$  Voltages

APPLICATION INFORMATION

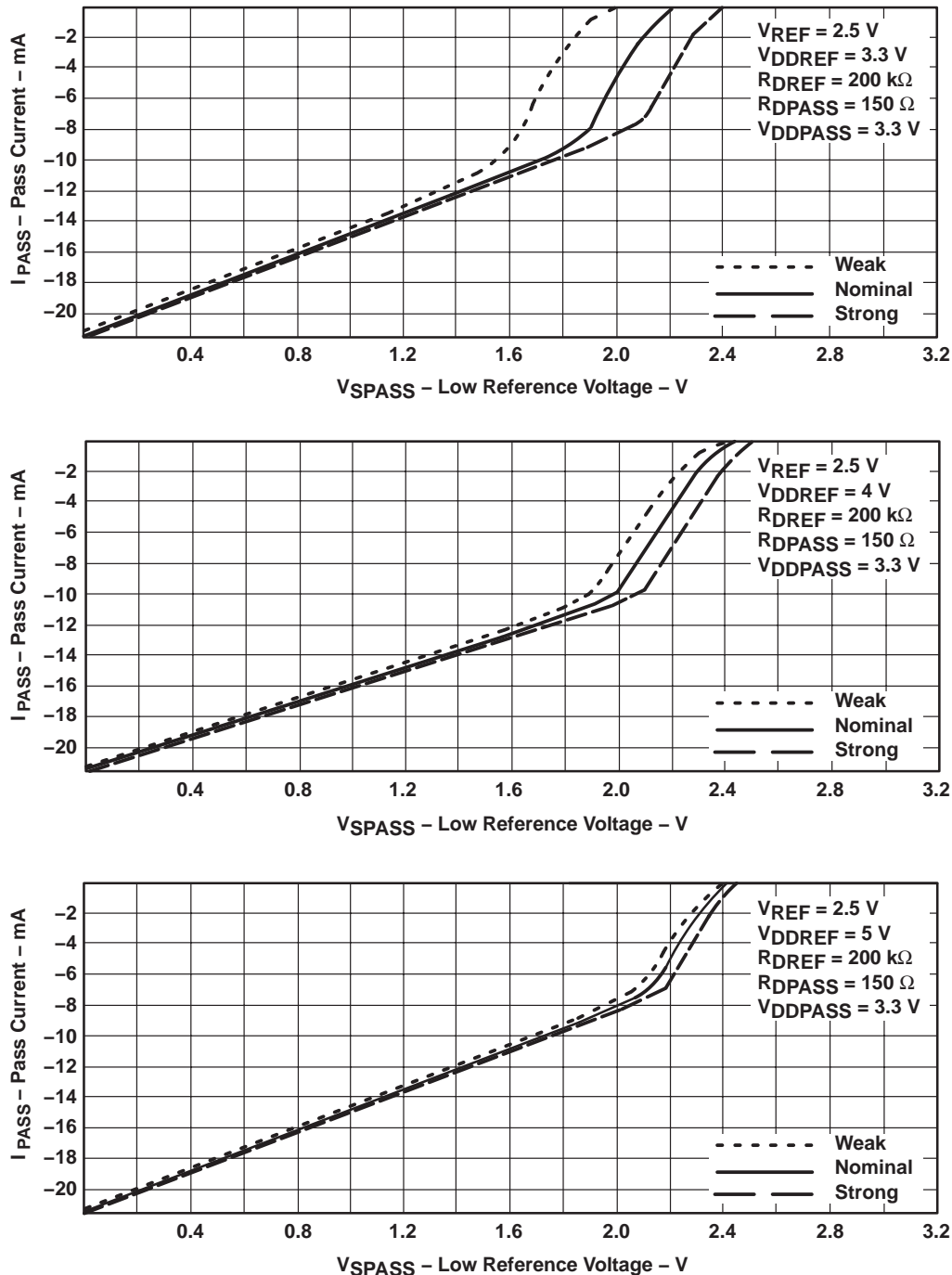

Figure 6. V-I Electrical Characteristics at  $V_{REF} = 2.5\text{ V}$

# SN74TVC16222A

## 22-BIT VOLTAGE CLAMP

SCDS087G – APRIL 1999 – REVISED APRIL 2005

### APPLICATION INFORMATION

#### features and benefits

The TVC family has several features that benefit a system designer when implementing a sensitive-I/O-protection solution. Table 1 lists these features and their associated benefits.

Table 1. Features and Benefits

FEATURES	BENEFITS
Any FET can be used as the reference transistor.	Ease of layout
All FETs on one die, tight process control	Very low spread of $V_O$ relative to $V_{REF}$
No active control logic (passive device)	No logic power supply ( $V_{CC}$ ) required
Flow-through pinout	Ease of trace routing
Devices offered in different bit widths and packages	Optimizes design and cost effectiveness
Designer flexibility with $V_{REF}$ input	Allows migration to lower-voltage I/Os without board redesign

#### conclusion

The TI TVC family provides the designer with a solution for protection of circuits with I/Os that are sensitive to high-state voltage-level overshoots. The flexibility of TVC enables a low-voltage migration path for advanced designs to align with industry standards.

#### frequently asked questions (FAQs)

- Q: Can any of the transistors in the array be used as the reference transistor?  
A: Yes, any transistor can be used as long as its  $V_{BIAS}$  pin is connected to the GATE pin.
- Q: In the *recommended operating conditions* table of the data sheet, the typical  $V_{BIAS}$  is 3.3 V. Should  $V_{BIAS}$  be equal to or greater than  $V_{REF}$  on the reference transistor?  
A:  $V_{BIAS}$  is a variable that is determined by  $V_{REF}$ .  $V_{BIAS}$  is connected to  $V_{DD}$  through a resistor to allow the bias voltage to be controlled by  $V_{REF}$ .  $V_{DD}$  can be as high as 5.5 V.  $V_{REF}$  needs to be at least 1 V less than  $V_{DDREF}$  on the reference transistor.
- Q: Do both A and B ports have 5-V I/O tolerance or is 5-V I/O tolerance provided only on the low-voltage side?  
A: Both ports are 5-V tolerant.

**PACKAGING INFORMATION**

Orderable Device	Status <sup>(1)</sup>	Package Type	Package Drawing	Pins	Package Qty	Eco Plan <sup>(2)</sup>	Lead/Ball Finish	MSL Peak Temp <sup>(3)</sup>
74TVC16222ADGGRE4	ACTIVE	TSSOP	DGG	48	2000	Green (RoHS & no Sb/Br)	CU NIPDAU	Level-1-260C-UNLIM
74TVC16222ADGGRG4	ACTIVE	TSSOP	DGG	48	2000	Green (RoHS & no Sb/Br)	CU NIPDAU	Level-1-260C-UNLIM
74TVC16222ADGVRE4	ACTIVE	TVSOP	DGV	48	2000	Green (RoHS & no Sb/Br)	CU NIPDAU	Level-1-260C-UNLIM
74TVC16222ADGVRG4	ACTIVE	TVSOP	DGV	48	2000	Green (RoHS & no Sb/Br)	CU NIPDAU	Level-1-260C-UNLIM
SN74TVC16222ADGGR	ACTIVE	TSSOP	DGG	48	2000	Green (RoHS & no Sb/Br)	CU NIPDAU	Level-1-260C-UNLIM
SN74TVC16222ADGVR	ACTIVE	TVSOP	DGV	48	2000	Green (RoHS & no Sb/Br)	CU NIPDAU	Level-1-260C-UNLIM
SN74TVC16222ADL	ACTIVE	SSOP	DL	48	25	Green (RoHS & no Sb/Br)	CU NIPDAU	Level-1-260C-UNLIM
SN74TVC16222ADLG4	ACTIVE	SSOP	DL	48	25	Green (RoHS & no Sb/Br)	CU NIPDAU	Level-1-260C-UNLIM
SN74TVC16222ADLR	ACTIVE	SSOP	DL	48	1000	Green (RoHS & no Sb/Br)	CU NIPDAU	Level-1-260C-UNLIM
SN74TVC16222ADLRG4	ACTIVE	SSOP	DL	48	1000	Green (RoHS & no Sb/Br)	CU NIPDAU	Level-1-260C-UNLIM

<sup>(1)</sup> The marketing status values are defined as follows:

**ACTIVE:** Product device recommended for new designs.

**LIFEBUY:** TI has announced that the device will be discontinued, and a lifetime-buy period is in effect.

**NRND:** Not recommended for new designs. Device is in production to support existing customers, but TI does not recommend using this part in a new design.

**PREVIEW:** Device has been announced but is not in production. Samples may or may not be available.

**OBSOLETE:** TI has discontinued the production of the device.

<sup>(2)</sup> Eco Plan - The planned eco-friendly classification: Pb-Free (RoHS), Pb-Free (RoHS Exempt), or Green (RoHS & no Sb/Br) - please check <http://www.ti.com/productcontent> for the latest availability information and additional product content details.

**TBD:** The Pb-Free/Green conversion plan has not been defined.

**Pb-Free (RoHS):** TI's terms "Lead-Free" or "Pb-Free" mean semiconductor products that are compatible with the current RoHS requirements for all 6 substances, including the requirement that lead not exceed 0.1% by weight in homogeneous materials. Where designed to be soldered at high temperatures, TI Pb-Free products are suitable for use in specified lead-free processes.

**Pb-Free (RoHS Exempt):** This component has a RoHS exemption for either 1) lead-based flip-chip solder bumps used between the die and package, or 2) lead-based die adhesive used between the die and leadframe. The component is otherwise considered Pb-Free (RoHS compatible) as defined above.

**Green (RoHS & no Sb/Br):** TI defines "Green" to mean Pb-Free (RoHS compatible), and free of Bromine (Br) and Antimony (Sb) based flame retardants (Br or Sb do not exceed 0.1% by weight in homogeneous material)

<sup>(3)</sup> MSL, Peak Temp. -- The Moisture Sensitivity Level rating according to the JEDEC industry standard classifications, and peak solder temperature.

**Important Information and Disclaimer:** The information provided on this page represents TI's knowledge and belief as of the date that it is provided. TI bases its knowledge and belief on information provided by third parties, and makes no representation or warranty as to the accuracy of such information. Efforts are underway to better integrate information from third parties. TI has taken and continues to take reasonable steps to provide representative and accurate information but may not have conducted destructive testing or chemical analysis on incoming materials and chemicals. TI and TI suppliers consider certain information to be proprietary, and thus CAS numbers and other limited information may not be available for release.

In no event shall TI's liability arising out of such information exceed the total purchase price of the TI part(s) at issue in this document sold by TI to Customer on an annual basis.

**TAPE AND REEL INFORMATION**

**QUADRANT ASSIGNMENTS FOR PIN 1 ORIENTATION IN TAPE**

\*All dimensions are nominal

Device	Package Type	Package Drawing	Pins	SPQ	Reel Diameter (mm)	Reel Width W1 (mm)	A0 (mm)	B0 (mm)	K0 (mm)	P1 (mm)	W (mm)	Pin1 Quadrant
SN74TVC16222ADGGR	TSSOP	DGG	48	2000	330.0	24.4	8.6	15.8	1.8	12.0	24.0	Q1
SN74TVC16222ADGVR	TVSOP	DGV	48	2000	330.0	16.4	7.1	10.2	1.6	12.0	16.0	Q1
SN74TVC16222ADLR	SSOP	DL	48	1000	330.0	32.4	11.35	16.2	3.1	16.0	32.0	Q1

**TAPE AND REEL BOX DIMENSIONS**

\*All dimensions are nominal

Device	Package Type	Package Drawing	Pins	SPQ	Length (mm)	Width (mm)	Height (mm)
SN74TVC16222ADGGR	TSSOP	DGG	48	2000	346.0	346.0	41.0
SN74TVC16222ADGVR	TVSOP	DGV	48	2000	346.0	346.0	33.0
SN74TVC16222ADLR	SSOP	DL	48	1000	346.0	346.0	49.0

DGG (R-PDSO-G\*\*)

PLASTIC SMALL-OUTLINE PACKAGE

48 PINS SHOWN



- NOTES: A. All linear dimensions are in millimeters.  
 B. This drawing is subject to change without notice.  
 C. Body dimensions do not include mold protrusion not to exceed 0,15.  
 D. Falls within JEDEC MO-153

DL (R-PDSO-G\*\*)

PLASTIC SMALL-OUTLINE PACKAGE

48 PINS SHOWN

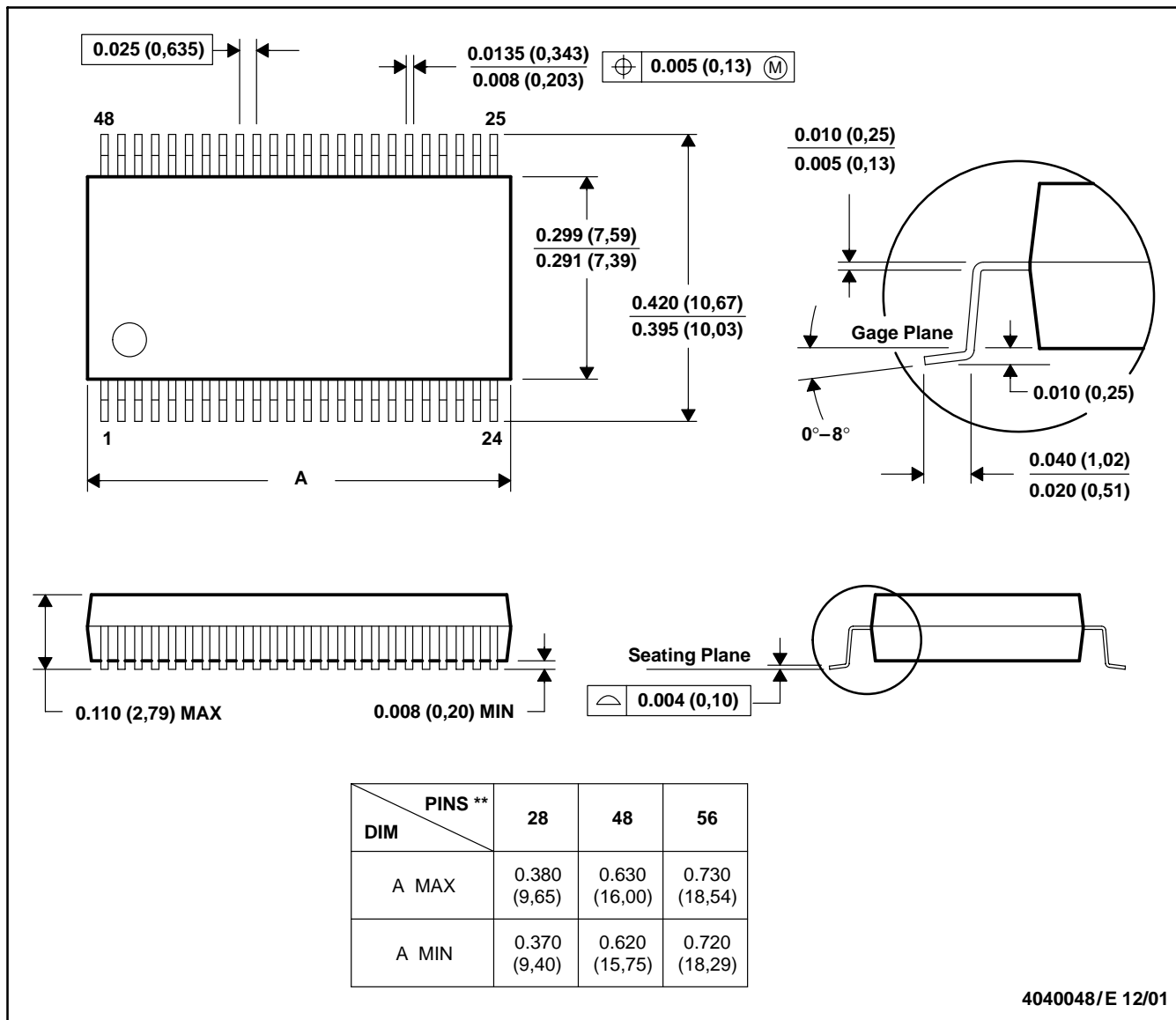

- NOTES: A. All linear dimensions are in inches (millimeters).  
 B. This drawing is subject to change without notice.  
 C. Body dimensions do not include mold flash or protrusion not to exceed 0.006 (0,15).  
 D. Falls within JEDEC MO-118

DGV (R-PDSO-G\*\*)

PLASTIC SMALL-OUTLINE

24 PINS SHOWN



- NOTES: A. All linear dimensions are in millimeters.  
 B. This drawing is subject to change without notice.  
 C. Body dimensions do not include mold flash or protrusion, not to exceed 0,15 per side.  
 D. Falls within JEDEC: 24/48 Pins – MO-153  
 14/16/20/56 Pins – MO-194

## IMPORTANT NOTICE

Texas Instruments Incorporated and its subsidiaries (TI) reserve the right to make corrections, modifications, enhancements, improvements, and other changes to its products and services at any time and to discontinue any product or service without notice. Customers should obtain the latest relevant information before placing orders and should verify that such information is current and complete. All products are sold subject to TI's terms and conditions of sale supplied at the time of order acknowledgment.

TI warrants performance of its hardware products to the specifications applicable at the time of sale in accordance with TI's standard warranty. Testing and other quality control techniques are used to the extent TI deems necessary to support this warranty. Except where mandated by government requirements, testing of all parameters of each product is not necessarily performed.

TI assumes no liability for applications assistance or customer product design. Customers are responsible for their products and applications using TI components. To minimize the risks associated with customer products and applications, customers should provide adequate design and operating safeguards.

TI does not warrant or represent that any license, either express or implied, is granted under any TI patent right, copyright, mask work right, or other TI intellectual property right relating to any combination, machine, or process in which TI products or services are used. Information published by TI regarding third-party products or services does not constitute a license from TI to use such products or services or a warranty or endorsement thereof. Use of such information may require a license from a third party under the patents or other intellectual property of the third party, or a license from TI under the patents or other intellectual property of TI.

Reproduction of TI information in TI data books or data sheets is permissible only if reproduction is without alteration and is accompanied by all associated warranties, conditions, limitations, and notices. Reproduction of this information with alteration is an unfair and deceptive business practice. TI is not responsible or liable for such altered documentation. Information of third parties may be subject to additional restrictions.

Resale of TI products or services with statements different from or beyond the parameters stated by TI for that product or service voids all express and any implied warranties for the associated TI product or service and is an unfair and deceptive business practice. TI is not responsible or liable for any such statements.

TI products are not authorized for use in safety-critical applications (such as life support) where a failure of the TI product would reasonably be expected to cause severe personal injury or death, unless officers of the parties have executed an agreement specifically governing such use. Buyers represent that they have all necessary expertise in the safety and regulatory ramifications of their applications, and acknowledge and agree that they are solely responsible for all legal, regulatory and safety-related requirements concerning their products and any use of TI products in such safety-critical applications, notwithstanding any applications-related information or support that may be provided by TI. Further, Buyers must fully indemnify TI and its representatives against any damages arising out of the use of TI products in such safety-critical applications.

TI products are neither designed nor intended for use in military/aerospace applications or environments unless the TI products are specifically designated by TI as military-grade or "enhanced plastic." Only products designated by TI as military-grade meet military specifications. Buyers acknowledge and agree that any such use of TI products which TI has not designated as military-grade is solely at the Buyer's risk, and that they are solely responsible for compliance with all legal and regulatory requirements in connection with such use.

TI products are neither designed nor intended for use in automotive applications or environments unless the specific TI products are designated by TI as compliant with ISO/TS 16949 requirements. Buyers acknowledge and agree that, if they use any non-designated products in automotive applications, TI will not be responsible for any failure to meet such requirements.

Following are URLs where you can obtain information on other Texas Instruments products and application solutions:

### Products

Amplifiers	<a href="http://amplifier.ti.com">amplifier.ti.com</a>
Data Converters	<a href="http://dataconverter.ti.com">dataconverter.ti.com</a>
DLP® Products	<a href="http://www.dlp.com">www.dlp.com</a>
DSP	<a href="http://dsp.ti.com">dsp.ti.com</a>
Clocks and Timers	<a href="http://www.ti.com/clocks">www.ti.com/clocks</a>
Interface	<a href="http://interface.ti.com">interface.ti.com</a>
Logic	<a href="http://logic.ti.com">logic.ti.com</a>
Power Mgmt	<a href="http://power.ti.com">power.ti.com</a>
Microcontrollers	<a href="http://microcontroller.ti.com">microcontroller.ti.com</a>
RFID	<a href="http://www.ti-rfid.com">www.ti-rfid.com</a>
RF/IF and ZigBee® Solutions	<a href="http://www.ti.com/lprf">www.ti.com/lprf</a>

### Applications

Audio	<a href="http://www.ti.com/audio">www.ti.com/audio</a>
Automotive	<a href="http://www.ti.com/automotive">www.ti.com/automotive</a>
Broadband	<a href="http://www.ti.com/broadband">www.ti.com/broadband</a>
Digital Control	<a href="http://www.ti.com/digitalcontrol">www.ti.com/digitalcontrol</a>
Medical	<a href="http://www.ti.com/medical">www.ti.com/medical</a>
Military	<a href="http://www.ti.com/military">www.ti.com/military</a>
Optical Networking	<a href="http://www.ti.com/opticalnetwork">www.ti.com/opticalnetwork</a>
Security	<a href="http://www.ti.com/security">www.ti.com/security</a>
Telephony	<a href="http://www.ti.com/telephony">www.ti.com/telephony</a>
Video & Imaging	<a href="http://www.ti.com/video">www.ti.com/video</a>
Wireless	<a href="http://www.ti.com/wireless">www.ti.com/wireless</a>

Mailing Address: Texas Instruments, Post Office Box 655303, Dallas, Texas 75265  
Copyright © 2009, Texas Instruments Incorporated

## Looking for pricing, stock, or lifecycle information?

Click below to explore more details on WIN SOURCE:

 [View SN74TVC16222ADGVR on WIN SOURCE](#)

 [Texas Instruments](#) Information

## Optimize Your Supply Chain with WIN SOURCE Solutions

-  Global Sourcing Solution
-  Obsolete Management
-  Cost Control Management
-  Shortage Management
-  Alternative Solution
-  Excess Inventory Management