



**THE DATASHEET OF
SN74LVC74ADBR**



SNx4LVC74A Dual Positive-Edge-Triggered D-Type Flip-Flops With Clear and Preset

1 Features

- Operate From 1.65 V to 3.6 V
- Inputs Accept Voltages to 5.5 V
- Maximum t_{pd} of 5.2 ns at 3.3 V
- Typical V_{OLP} (Output Ground Bounce) <0.8 V at $V_{CC} = 3.3$ V, $T_A = 25^\circ\text{C}$
- Typical V_{OHV} (Output V_{OH} Undershoot) >2 V at $V_{CC} = 3.3$ V, $T_A = 25^\circ\text{C}$
- Latch-Up Performance Exceeds 250 mA Per JESD 17
- ESD Protection Exceeds JESD 22
 - 2000-V Human-Body Model (A114-A)
 - 1000-V Charged-Device Model (C101)

2 Applications

- Servers
- Medical, Healthcare, and Fitness
- Telecom Infrastructures
- TVs, Set-Top Boxes, and Audio
- Test and Measurement
- Industrial Transport
- Wireless Infrastructure
- Enterprise Switching
- Motor Drives
- Factory Automation and Control

3 Description

The SNx4LVC74A devices integrate two positive-edge triggered D-type flip-flops in one convenient device.

The SN54LVC74A is designed for 2.7-V to 3.6-V V_{CC} operation, and the SN74LVC74A is designed for 1.65-V to 3.6-V V_{CC} operation.

A low level at the preset ($\overline{\text{PRE}}$) or clear ($\overline{\text{CLR}}$) inputs sets or resets the outputs, regardless of the levels of the other inputs. When $\overline{\text{PRE}}$ and $\overline{\text{CLR}}$ are inactive (high), data at the data (D) input meeting the setup time requirements is transferred to the outputs on the positive-going edge of the clock pulse. Clock triggering occurs at a voltage level and is not directly related to the rise time of the clock pulse. Following the hold-time interval, data at the D input can be changed without affecting the levels at the outputs.

The data I/Os and control inputs are overvoltage tolerant. This feature allows the use of these devices for down-translation in a mixed-voltage environment.

Device Information⁽¹⁾

PART NUMBER	PACKAGE	BODY SIZE (NOM)
SNJ54LVC74AFK	LCCC (20)	8.89 mm x 8.89 mm
SNJ54LVC74AJ	CDIP (14)	19.56 mm x 6.67 mm
SNJ54LVC74AW	CFP (14)	9.21 mm x 5.97 mm
SN74LVC74AD	SOIC (14)	8.65 mm x 3.91 mm
SN74LVC74ADB	SSOP (14)	6.20 mm x 5.30 mm
SN74LVC74ANS	SO (14)	10.30 mm x 5.30 mm
SN74LVC74APW	TSSOP (14)	5.00 mm x 4.40 mm
SN74LVC74ARGY	VQFN (14)	3.50 mm x 3.50 mm

(1) For all available packages, see the orderable addendum at the end of the data sheet.

Logic Diagram, Each Flip-Flop (Positive Logic)

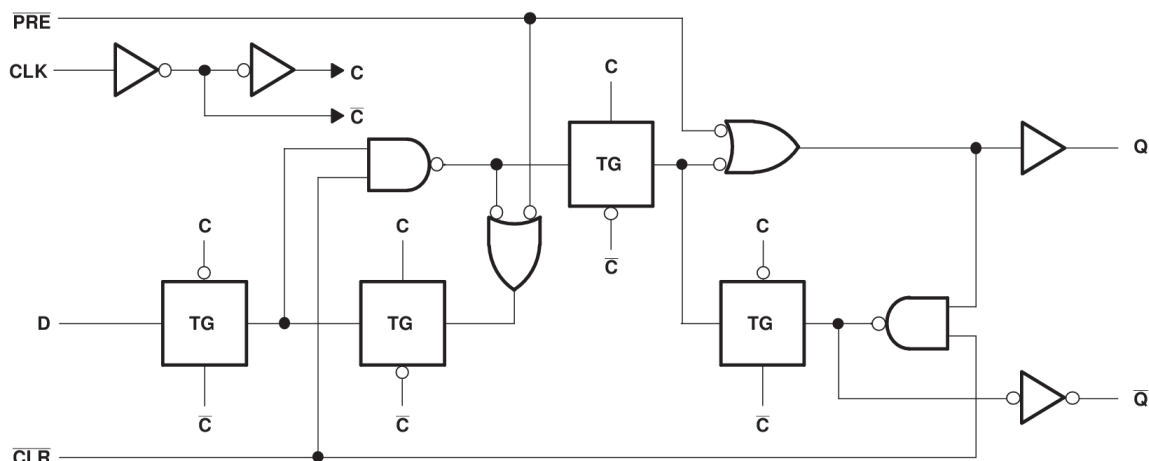

Copyright © 2016, Texas Instruments Incorporated



An IMPORTANT NOTICE at the end of this data sheet addresses availability, warranty, changes, use in safety-critical applications, intellectual property matters and other important disclaimers. PRODUCTION DATA.

On products compliant to MIL-PRF-38535, all parameters are tested unless otherwise noted. On all other products, production

Table of Contents

1 Features	1	8 Detailed Description	10
2 Applications	1	8.1 Overview	10
3 Description	1	8.2 Functional Block Diagram	10
4 Revision History	2	8.3 Feature Description	10
5 Pin Configuration and Functions	3	8.4 Device Functional Modes	10
6 Specifications	4	9 Application and Implementation	11
6.1 Absolute Maximum Ratings	4	9.1 Application Information	11
6.2 ESD Ratings	4	9.2 Typical Application	11
6.3 Recommended Operating Conditions	4	10 Power Supply Recommendations	13
6.4 Thermal Information: SN74LVC74A	5	11 Layout	13
6.5 Electrical Characteristics	5	11.1 Layout Guidelines	13
6.6 Timing Requirements: SN54LVC74A	6	11.2 Layout Example	13
6.7 Timing Requirements: SN74LVC74A	6	12 Device and Documentation Support	14
6.8 Timing Requirements: SN74LVC74A, –40°C to 125°C and –40°C to 85°C	7	12.1 Documentation Support	14
6.9 Switching Characteristics: SN54LVC74A	7	12.2 Related Links	14
6.10 Switching Characteristics: SN74LVC74A	7	12.3 Receiving Notification of Documentation Updates	14
6.11 Switching Characteristics: SN74LVC74A, –40°C to 125°C and –40°C to 85°C	8	12.4 Community Resource	14
6.12 Operating Characteristics	8	12.5 Trademarks	14
6.13 Typical Characteristics	8	12.6 Electrostatic Discharge Caution	14
7 Parameter Measurement Information	9	12.7 Glossary	14
		13 Mechanical, Packaging, and Orderable Information	14

4 Revision History

NOTE: Page numbers for previous revisions may differ from page numbers in the current version.

Changes from Revision T (July 2013) to Revision U	Page
<ul style="list-style-type: none"> Added <i>ESD Ratings</i> table, <i>Feature Description</i> section, <i>Device Functional Modes</i>, <i>Application and Implementation</i> section, <i>Power Supply Recommendations</i> section, <i>Layout</i> section, <i>Device and Documentation Support</i> section, and <i>Mechanical, Packaging, and Orderable Information</i> section 	1
<ul style="list-style-type: none"> Changed Package thermal impedance, $R_{\theta JA}$, values in <i>Thermal Information: SN74LVC74A</i> From: 86 To: 93.7 (D), From: 96 To: 107.3 (DB), From: 76 To: 90.3 (NS), From: 113 To: 121.7 (PW), and From: 47 To: 54.9 (RGY) 	5

Changes from Revision S (May 2005) to Revision T	Page
<ul style="list-style-type: none"> Extended maximum temperature operating range from 85°C to 125°C 	4

5 Pin Configuration and Functions

D, DB, J, PW, NS, or W Package
14-Pin SOIC, SSOP, CDIP, TSSOP, SO, or CFP
Top View

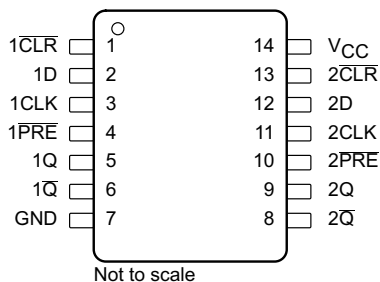

RGY Package
14-Pin VQFN With Exposed Thermal Pad
Top View

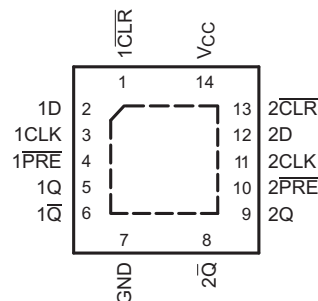

FK Package
20-Pin LCCC
Top View

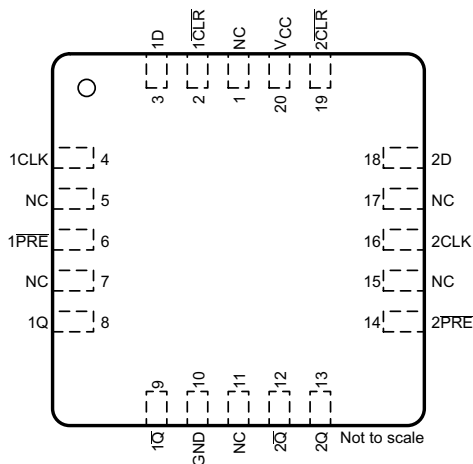

Pin Functions

NAME	PIN		I/O	DESCRIPTION
	CDIP, CFP, PDIP, SO, SOIC, SSOP, TSSOP, VQFN	LCCC		
1CLK	3	4	I	Channel 1 clock input
1 $\overline{\text{CLR}}$	1	2	I	Channel 1 clear input. Pull low to set Q output low.
1D	2	3	I	Channel 1 data input
1 $\overline{\text{PRE}}$	4	6	I	Channel 1 preset input. Pull low to set Q output high.
1Q	5	8	O	Channel 1 output
1 $\overline{\text{Q}}$	6	9	O	Channel 1 inverted output
2CLK	11	16	I	Channel 2 clock input
2 $\overline{\text{CLR}}$	13	19	I	Channel 2 clear input. Pull low to set Q output low.
2D	12	18	I	Channel 2 data input
2 $\overline{\text{PRE}}$	10	14	I	Channel 2 preset input. Pull low to set Q output high.
2Q	9	13	O	Channel 2 output
2 $\overline{\text{Q}}$	8	12	O	Channel 2 Inverted output
GND	7	10	—	Ground
NC	—	1, 5, 7, 11, 15, 17	—	No connect
V _{CC}	14	20	—	Supply

6 Specifications

6.1 Absolute Maximum Ratings

over operating free-air temperature range (unless otherwise noted)⁽¹⁾

	MIN	MAX	UNIT
Supply voltage, V_{CC}	-0.5	6.5	V
Input voltage, V_I ⁽²⁾	-0.5	6.5	V
Output voltage, V_O ⁽²⁾⁽³⁾	-0.5	$V_{CC} + 0.5$	V
Input clamp current, I_{IK}	$V_I < 0$	-50	mA
Output clamp current, I_{OK}	$V_O < 0$	-50	mA
Continuous output current, I_O		± 50	mA
Continuous current through V_{CC} or GND		± 100	mA
Storage temperature, T_{stg}	-65	150	°C

- (1) Stresses beyond those listed under *Absolute Maximum Ratings* may cause permanent damage to the device. These are stress ratings only, which do not imply functional operation of the device at these or any other conditions beyond those indicated under *Recommended Operating Conditions*. Exposure to absolute-maximum-rated conditions for extended periods may affect device reliability.
- (2) The input and output negative-voltage ratings may be exceeded if the input and output current ratings are observed.
- (3) The value of V_{CC} is provided in *Recommended Operating Conditions*.

6.2 ESD Ratings

	VALUE	UNIT
$V_{(ESD)}$ Electrostatic discharge	Human-body model (HBM), per ANSI/ESDA/JEDEC JS-001 ⁽¹⁾	± 2000
	Charged-device model (CDM), per JEDEC specification JESD22-C101 ⁽²⁾	± 1000

- (1) JEDEC document JEP155 states that 500-V HBM allows safe manufacturing with a standard ESD control process.
- (2) JEDEC document JEP157 states that 250-V CDM allows safe manufacturing with a standard ESD control process.

6.3 Recommended Operating Conditions

see⁽¹⁾

			MIN	MAX	UNIT
V_{CC} Supply voltage	Operating	SN54LVC74A	2	3.6	V
		SN74LVC74A	1.65	3.6	
	Data retention only		1.5		
V_{IH} High-level input voltage	$V_{CC} = 1.65\text{ V to }1.95\text{ V}$	SN74LVC74A	$0.65 \times V_{CC}$		V
	$V_{CC} = 2.3\text{ V to }2.7\text{ V}$	SN74LVC74A	1.7		
	$V_{CC} = 2.7\text{ V to }3.6\text{ V}$		2		
V_{IL} Low-level input voltage	$V_{CC} = 1.65\text{ V to }1.95\text{ V}$	SN74LVC74A	$0.35 \times V_{CC}$		V
	$V_{CC} = 2.3\text{ V to }2.7\text{ V}$	SN74LVC74A	0.7		
	$V_{CC} = 2.7\text{ V to }3.6\text{ V}$		0.8		
V_I Input voltage			0	5.5	V
V_O Output voltage			0	V_{CC}	V
I_{OH} High-level output current	$V_{CC} = 1.65\text{ V}$	SN74LVC74A	-4		mA
	$V_{CC} = 2.3\text{ V}$	SN74LVC74A	-8		
	$V_{CC} = 2.7\text{ V}$		-12		
	$V_{CC} = 3\text{ V}$		-24		
I_{OL} Low-level output current	$V_{CC} = 1.65\text{ V}$	SN74LVC74A	4		mA
	$V_{CC} = 2.3\text{ V}$	SN74LVC74A	8		
	$V_{CC} = 2.7\text{ V}$		12		
	$V_{CC} = 3\text{ V}$		24		
$\Delta t/\Delta v$ Input transition rise or fall rate				10	ns/V

- (1) All unused inputs of the device must be held at V_{CC} or GND to ensure proper device operation. See the TI application report, *Implications of Slow or Floating CMOS Inputs* (SCBA004).

Recommended Operating Conditions (continued)

 see⁽¹⁾

			MIN	MAX	UNIT
T _A	Operating free-air temperature	SN54LVC74A	-55	125	°C
		SN74LVC74A	-40	125	

6.4 Thermal Information: SN74LVC74A

THERMAL METRIC ⁽¹⁾	SN74LVC74A					UNIT	
	D (SOIC)	DB (SSOP)	NS (SO)	PW (TSSOP)	RGY (VQFN)		
	14 PINS	14 PINS	14 PINS	14 PINS	14 PINS		
R _{θJA}	Junction-to-ambient thermal resistance	93.7	107.3	90.3	121.7	54.9	°C/W
R _{θJC(top)}	Junction-to-case (top) thermal resistance	54.8	59.2	48.1	50.3	52.2	°C/W
R _{θJB}	Junction-to-board thermal resistance	48	54.6	49.1	63.4	30.8	°C/W
ψ _{JT}	Junction-to-top characterization parameter	20.3	24.1	17.9	6.2	2.4	°C/W
ψ _{JB}	Junction-to-board characterization parameter	47.7	54.1	48.8	62.8	30.9	°C/W
R _{θJC(bot)}	Junction-to-case (bottom) thermal resistance	—	—	—	—	12.5	°C/W

(1) For more information about traditional and new thermal metrics, see the [Semiconductor and IC Package Thermal Metrics](#) application report.

6.5 Electrical Characteristics

over recommended operating free-air temperature range (unless otherwise noted)

PARAMETER	TEST CONDITIONS		MIN	TYP	MAX	UNIT
V _{OH}	High-level output voltage	I _{OH} = -100 μA	V _{CC} = 1.65 V to 3.6 V and T _A = -55°C to 125°C (SN54LVC74A only)	V _{CC} - 0.2		V
			V _{CC} = 2.7 V to 3.6 V and T _A = -40°C to 125°C (SN74LVC74A only)	V _{CC} - 0.2		
		I _{OH} = -4 mA, V _{CC} = 1.65 V, and T _A = -40°C to 125°C (SN74LVC74A only)	1.2			
		I _{OH} = -8 mA, V _{CC} = 2.3 V, and T _A = -40°C to 125°C (SN74LVC74A only)	1.7			
		I _{OH} = -12 mA	V _{CC} = 2.7 V	2.2		
			V _{CC} = 3 V	2.4		
V _{OL}	Low-level output voltage	I _{OL} = 100 μA	V _{CC} = 1.65 V to 3.6 V, and T _A = -40°C to 125°C (SN74LVC74A only)	0.2		V
				V _{CC} = 2.7 V to 3.6 V and T _A = -55°C to 125°C (SN54LVC74A only)	0.2	
			I _{OL} = 4 mA, V _{CC} = 1.65 V, and T _A = -40°C to 125°C (SN74LVC74A only)	0.45		
			I _{OL} = 8 mA, V _{CC} = 2.3 V, and T _A = -40°C to 125°C (SN74LVC74A only)	0.7		
			I _{OL} = 12 mA, V _{CC} = 2.7 V	0.4		
			I _{OL} = 24 mA, V _{CC} = 3 V	0.55		
I _I	Input current	V _I = 5.5 V or GND, V _{CC} = 3.6 V		±5		μA
I _{CC}	Supply current	V _I = V _{CC} or GND, I _O = 0, V _{CC} = 3.6 V		10		μA
ΔI _{CC}	Change in supply current	One input at V _{CC} - 0.6 V, other inputs at V _{CC} or GND, and V _{CC} = 2.7 V to 3.6 V		500		μA
C _i	Input capacitance	V _I = V _{CC} or GND, V _{CC} = 3.3 V, T _A = 25°C		5		pF

SN54LVC74A, SN74LVC74A

SCAS287U – JANUARY 1993 – REVISED JANUARY 2017

www.ti.com
6.6 Timing Requirements: SN54LVC74A

 over recommended operating free-air temperature range (unless otherwise noted; see [Figure 3](#))

			MIN	MAX	UNIT
f_{clock}	Clock frequency	$V_{\text{CC}} = 2.7 \text{ V}$		83	MHz
		$V_{\text{CC}} = 3.3 \text{ V} \pm 0.3 \text{ V}$		100	
t_w	Pulse duration	$\overline{\text{PRE}}$ or $\overline{\text{CLR}}$ low	3.3		ns
		CLK high or low	3.3		
t_{su}	Setup time before CLK \uparrow	Data	$V_{\text{CC}} = 2.7 \text{ V}$	3.4	ns
			$V_{\text{CC}} = 3.3 \text{ V} \pm 0.3 \text{ V}$	3	
		$\overline{\text{PRE}}$ or $\overline{\text{CLR}}$ inactive	$V_{\text{CC}} = 2.7 \text{ V}$	2.2	
			$V_{\text{CC}} = 3.3 \text{ V} \pm 0.3 \text{ V}$	2	
t_h	Hold time, data after CLK \uparrow		1	ns	

6.7 Timing Requirements: SN74LVC74A

 over recommended operating free-air temperature range (unless otherwise noted; see [Figure 3](#))

			MIN	MAX	UNIT
f_{clock}	Clock frequency	$V_{\text{CC}} = 1.8 \text{ V}$ or 2.5 V		83	MHz
t_w	Pulse duration	$\overline{\text{PRE}}$ or $\overline{\text{CLR}}$ low	$V_{\text{CC}} = 1.8 \text{ V} \pm 0.15 \text{ V}$	4.1	ns
			$V_{\text{CC}} = 2.5 \text{ V} \pm 0.2 \text{ V}$	3.3	
		CLK high or low	$V_{\text{CC}} = 1.8 \text{ V} \pm 0.15 \text{ V}$	4.1	
			$V_{\text{CC}} = 2.5 \text{ V} \pm 0.2 \text{ V}$	3.3	
t_{su}	Setup time before CLK \uparrow	Data	$V_{\text{CC}} = 1.8 \text{ V} \pm 0.15 \text{ V}$	3.6	ns
			$V_{\text{CC}} = 2.5 \text{ V} \pm 0.2 \text{ V}$	2.3	
		$\overline{\text{PRE}}$ or $\overline{\text{CLR}}$ inactive	$V_{\text{CC}} = 1.8 \text{ V} \pm 0.15 \text{ V}$	2.7	
			$V_{\text{CC}} = 2.5 \text{ V} \pm 0.2 \text{ V}$	1.9	
t_h	Hold time, data after CLK \uparrow	$V_{\text{CC}} = 1.8 \text{ V}$ or 2.5 V	1	ns	

6.8 Timing Requirements: SN74LVC74A, –40°C to 125°C and –40°C to 85°C

 over recommended operating free-air temperature range (unless otherwise noted; see [Figure 3](#))

			MIN	MAX	UNIT	
f_{clock}	Clock frequency	$T_A = -40^\circ\text{C}$ to 125°C	$V_{\text{CC}} = 2.7\text{ V}$	83	MHz	
			$V_{\text{CC}} = 3.3\text{ V} \pm 0.3\text{ V}$	100		
		$T_A = -40^\circ\text{C}$ to 85°C and $V_{\text{CC}} = 3.3\text{ V} \pm 0.3\text{ V}$		150		
t_w	Pulse duration	$\overline{\text{PRE}}$ or $\overline{\text{CLR}}$ low	$V_{\text{CC}} = 2.7\text{ V}$ or 3.3 V	3.3	ns	
		CLK high or low	$V_{\text{CC}} = 2.7\text{ V}$ or 3.3 V	3.3		
t_{su}	Setup time before CLK \uparrow	Data	$T_A = -40^\circ\text{C}$ to 125°C	$V_{\text{CC}} = 2.7\text{ V}$	3.4	ns
				$V_{\text{CC}} = 3.3\text{ V} \pm 0.3\text{ V}$	3	
			$T_A = -40^\circ\text{C}$ to 85°C and $V_{\text{CC}} = 3.3\text{ V} \pm 0.3\text{ V}$		3	
		$\overline{\text{PRE}}$ or $\overline{\text{CLR}}$ inactive	$T_A = -40^\circ\text{C}$ to 125°C	$V_{\text{CC}} = 2.7\text{ V}$	2.2	
				$V_{\text{CC}} = 3.3\text{ V} \pm 0.3\text{ V}$	2	
$T_A = -40^\circ\text{C}$ to 85°C and $V_{\text{CC}} = 3.3\text{ V} \pm 0.3\text{ V}$		2				
t_h	Hold time, data after CLK \uparrow	$V_{\text{CC}} = 2.7\text{ V}$ or 3.3 V		1	ns	

6.9 Switching Characteristics: SN54LVC74A

 over recommended operating free-air temperature range (unless otherwise noted; see [Figure 3](#))

PARAMETER	FROM (INPUT)	TO (OUTPUT)	TEST CONDITIONS	MIN	MAX	UNIT
f_{max}	—	—	$V_{\text{CC}} = 2.7\text{ V}$	83	100	MHz
			$V_{\text{CC}} = 3.3\text{ V} \pm 0.3\text{ V}$			
t_{pd}	CLK	Q or \overline{Q}	$V_{\text{CC}} = 2.7\text{ V}$		6	ns
			$V_{\text{CC}} = 2.7\text{ V}$	1	5.2	
	$V_{\text{CC}} = 3.3\text{ V} \pm 0.3\text{ V}$			6.4		
	$V_{\text{CC}} = 3.3\text{ V} \pm 0.3\text{ V}$		1	5.4		
	$\overline{\text{PRE}}$ or $\overline{\text{CLR}}$					

6.10 Switching Characteristics: SN74LVC74A

 over recommended operating free-air temperature range (unless otherwise noted; see [Figure 3](#))

PARAMETER	FROM (INPUT)	TO (OUTPUT)	TEST CONDITIONS	MIN	MAX	UNIT
f_{max}	—	—		83		MHz
t_{pd}	CLK $\overline{\text{PRE}}$	Q or \overline{Q}	$V_{\text{CC}} = 1.8\text{ V} \pm 0.15\text{ V}$	1	7.1	ns
			$V_{\text{CC}} = 2.5\text{ V} \pm 0.2\text{ V}$	1	4.4	
	or $\overline{\text{CLR}}$		$V_{\text{CC}} = 1.8\text{ V} \pm 0.15\text{ V}$	1	6.9	
			$V_{\text{CC}} = 2.5\text{ V} \pm 0.2\text{ V}$	1	4.6	

6.11 Switching Characteristics: SN74LVC74A, –40°C to 125°C and –40°C to 85°C

over recommended operating free-air temperature range (unless otherwise noted; see Figure 3)

PARAMETER	FROM (INPUT)	TO (OUTPUT)	TEST CONDITIONS		MIN	MAX	UNIT
f_{max} Maximum clock frequency	—	—	$T_A = -40^\circ\text{C to } 125^\circ\text{C}$	$V_{CC} = 2.7\text{ V}$	83	MHz	
				$V_{CC} = 3.3\text{ V} \pm 0.3\text{ V}$	100		
			$T_A = -40^\circ\text{C to } 85^\circ\text{C}$ and $V_{CC} = 3.3\text{ V} \pm 0.3\text{ V}$	150			
t_{pd} Propagation (delay) time	CLK	Q or \bar{Q}	$T_A = -40^\circ\text{C to } 125^\circ\text{C}$	$V_{CC} = 2.7\text{ V}$	1	6	ns
				$V_{CC} = 3.3\text{ V} \pm 0.3\text{ V}$	1	5.2	
			$T_A = -40^\circ\text{C to } 85^\circ\text{C}$ and $V_{CC} = 3.3\text{ V} \pm 0.3\text{ V}$	$V_{CC} = 2.7\text{ V}$	1	6.4	
				$V_{CC} = 3.3\text{ V} \pm 0.3\text{ V}$	1	5.4	
				$T_A = -40^\circ\text{C to } 85^\circ\text{C}$ and $V_{CC} = 3.3\text{ V} \pm 0.3\text{ V}$	1	5.4	
$t_{sk(o)}$ Skew (time), output	—	—	$T_A = -40^\circ\text{C to } 85^\circ\text{C}$ and $V_{CC} = 3.3\text{ V} \pm 0.3\text{ V}$		1	ns	

6.12 Operating Characteristics

$T_A = 25^\circ\text{C}$

PARAMETER	TEST CONDITIONS	TYP	UNIT	
C_{pd} Power dissipation capacitance per flip-flop	$f = 10\text{ MHz}$	$V_{CC} = 1.8\text{ V}$	24	pF
		$V_{CC} = 2.5\text{ V}$	24	
		$V_{CC} = 3.3\text{ V}$	26	

6.13 Typical Characteristics

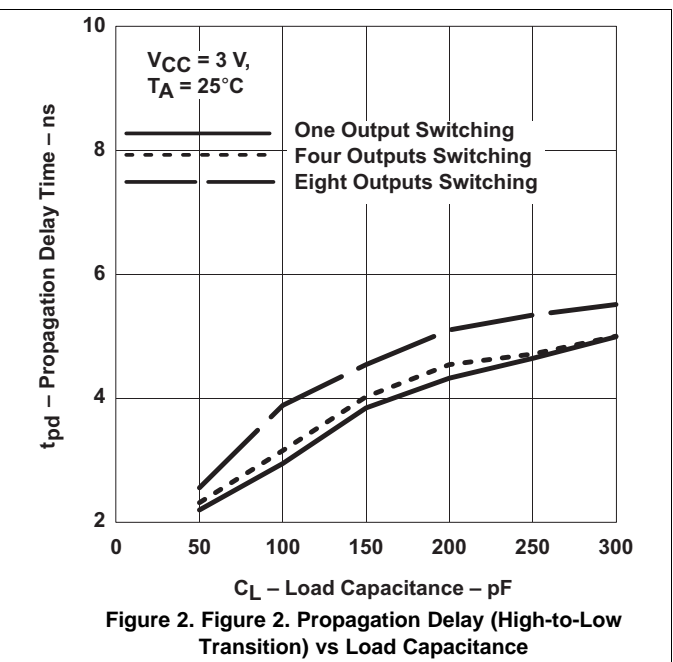
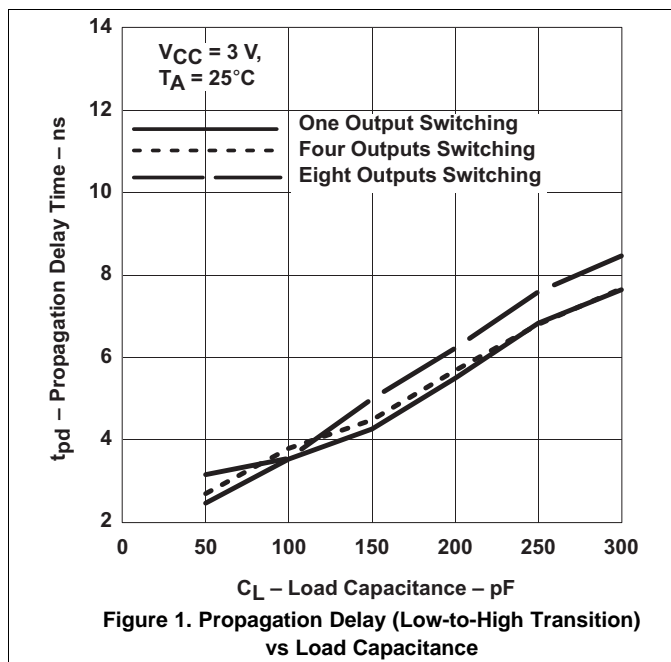

7 Parameter Measurement Information

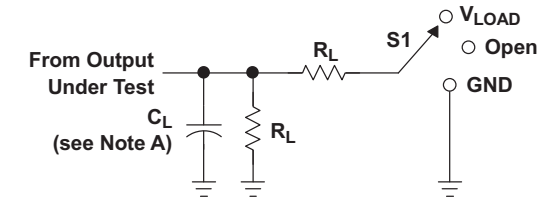

LOAD CIRCUIT

TEST	S1
t_{PLH}/t_{PHL}	Open
t_{PLZ}/t_{PZL}	V_{LOAD}
t_{PHZ}/t_{PZH}	GND

V_{CC}	INPUTS		V_M	V_{LOAD}	C_L	R_L	V_{Δ}
	V_I	t_r/t_f					
$1.8\text{ V} \pm 0.15\text{ V}$	V_{CC}	$\leq 2\text{ ns}$	$V_{CC}/2$	$2 \times V_{CC}$	30 pF	1 k Ω	0.15 V
$2.5\text{ V} \pm 0.2\text{ V}$	V_{CC}	$\leq 2\text{ ns}$	$V_{CC}/2$	$2 \times V_{CC}$	30 pF	500 Ω	0.15 V
2.7 V	2.7 V	$\leq 2.5\text{ ns}$	1.5 V	6 V	50 pF	500 Ω	0.3 V
$3.3\text{ V} \pm 0.3\text{ V}$	2.7 V	$\leq 2.5\text{ ns}$	1.5 V	6 V	50 pF	500 Ω	0.3 V

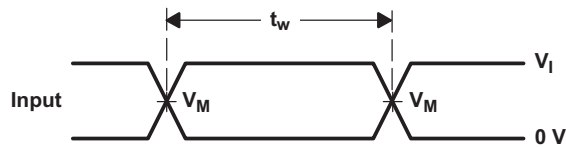

VOLTAGE WAVEFORMS PULSE DURATION

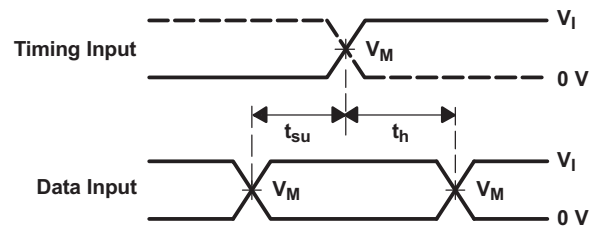

VOLTAGE WAVEFORMS SETUP AND HOLD TIMES

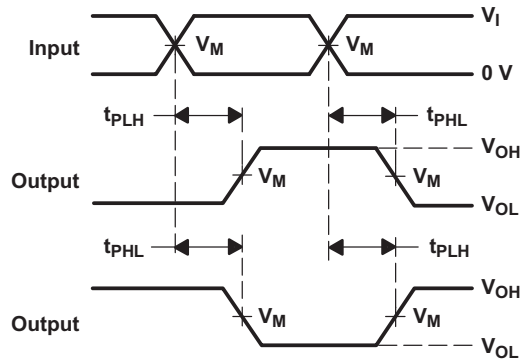

VOLTAGE WAVEFORMS PROPAGATION DELAY TIMES INVERTING AND NONINVERTING OUTPUTS

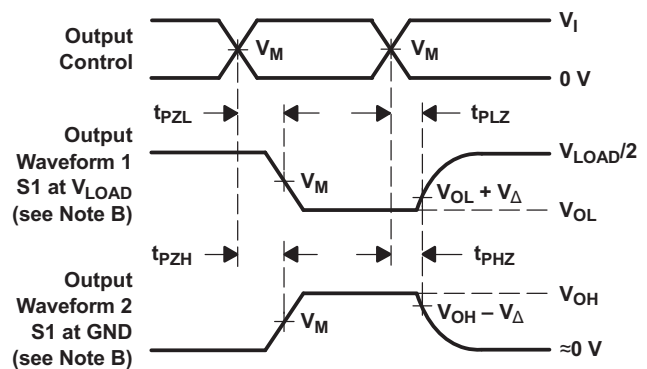

VOLTAGE WAVEFORMS ENABLE AND DISABLE TIMES LOW- AND HIGH-LEVEL ENABLING

- C_L includes probe and jig capacitance.
- Waveform 1 is for an output with internal conditions such that the output is low, except when disabled by the output control. Waveform 2 is for an output with internal conditions such that the output is high, except when disabled by the output control.
- All input pulses are supplied by generators having the following characteristics: PRR $\leq 10\text{ MHz}$, $Z_O = 50\ \Omega$.
- The outputs are measured one at a time, with one transition per measurement.
- t_{PLZ} and t_{PHZ} are the same as t_{dis} .
- t_{PZL} and t_{PZH} are the same as t_{en} .
- t_{PLH} and t_{PHL} are the same as t_{pd} .
- All parameters and waveforms are not applicable to all devices.

Figure 3. Load Circuit and Voltage Waveforms

8 Detailed Description

8.1 Overview

The SNx4LVC74A devices feature two independent positive-edge triggered D flip-flops. Integrated preset ($\overline{\text{PRE}}$) and clear ($\overline{\text{CLR}}$) functions allow for easy setup and control during operation.

The SN54LVC74A device is specified from -55°C to 125°C , and the SN74LVC74A device is specified from -40°C to 125°C .

8.2 Functional Block Diagram

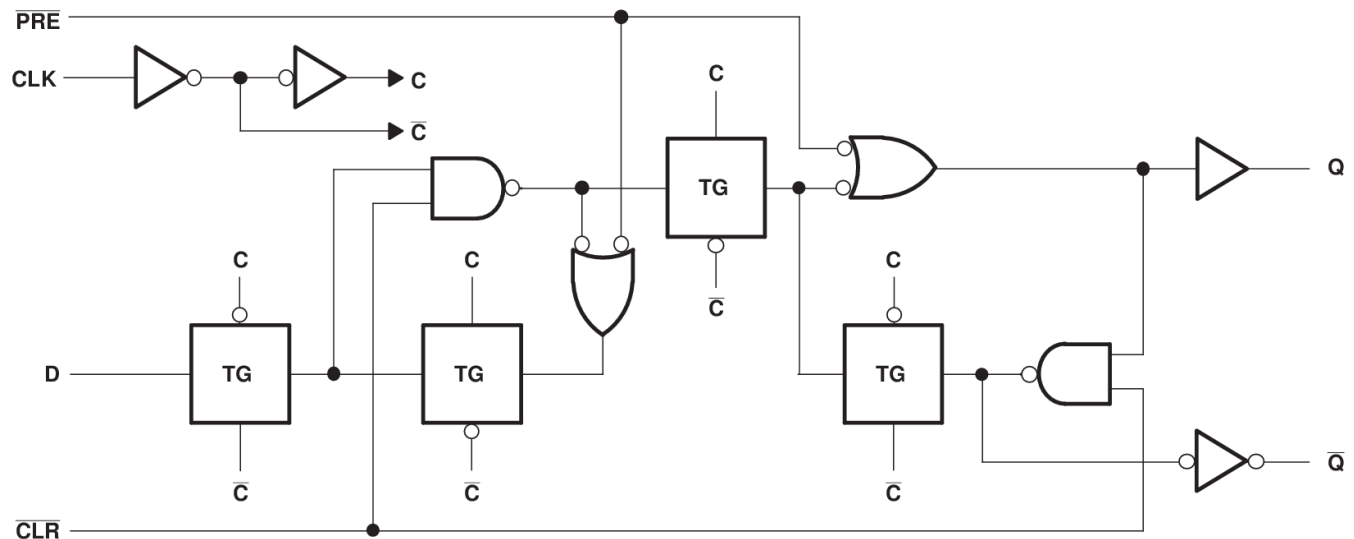

Copyright © 2016, Texas Instruments Incorporated

8.3 Feature Description

A low level at the preset ($\overline{\text{PRE}}$) or clear ($\overline{\text{CLR}}$) inputs sets or resets the outputs, regardless of the levels of the other inputs. When $\overline{\text{PRE}}$ and $\overline{\text{CLR}}$ are inactive (high), data at the data (D) input meeting the setup time requirements is transferred to the outputs on the positive-going edge of the clock pulse. Clock triggering occurs at a voltage level and is not directly related to the rise time of the clock pulse. Following the hold-time interval, data at the D input can be changed without affecting the levels at the outputs.

8.4 Device Functional Modes

Table 1 describes the SNx4LVC74A functionality and interactions between the $\overline{\text{PRE}}$, $\overline{\text{CLR}}$, CLK, and D inputs.

Table 1. Function Table

INPUTS				OUTPUTS	
$\overline{\text{PRE}}$	$\overline{\text{CLR}}$	CLK	D	Q	$\overline{\text{Q}}$
L	H	X	X	H	L
H	L	X	X	L	H
L	L	X	X	H ⁽¹⁾	H ⁽¹⁾
H	H	↑	H	H	L
H	H	↑	L	L	H
H	H	L	X	Q ₀	$\overline{\text{Q}}_0$

(1) This configuration is nonstable; that is, it does not persist when $\overline{\text{PRE}}$ or $\overline{\text{CLR}}$ returns to its inactive (high) level.

9 Application and Implementation

NOTE

Information in the following applications sections is not part of the TI component specification, and TI does not warrant its accuracy or completeness. TI's customers are responsible for determining suitability of components for their purposes. Customers should validate and test their design implementation to confirm system functionality.

9.1 Application Information

A common application for the SN74LVC74A is a frequency divider. By connecting the \bar{Q} output to the D input, the Q output toggles states on each positive edge of the incoming clock signal. Because it takes two positive edges, or two clock pulses, to complete one complete pulse on the output (one pulse to toggle from low to high, another to toggle from high to low), the incoming clock frequency is effectively divided by two.

9.2 Typical Application

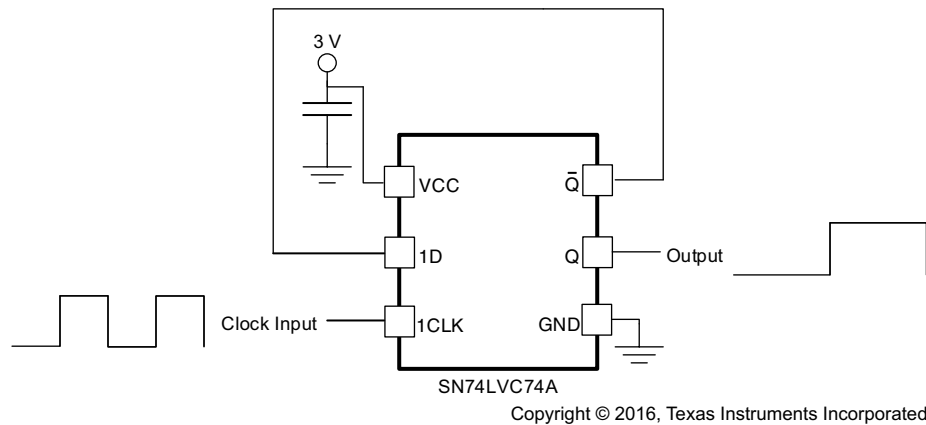

Figure 4. Frequency Divider

9.2.1 Design Requirements

This device uses CMOS technology and has balanced output drive. Avoid bus contention because it can drive currents in excess of maximum limits. The high drive also creates fast edges into light loads, so consider routing and load conditions to prevent ringing.

9.2.2 Detailed Design Procedure

1. Recommended input conditions:
 - For rise time and fall time specification, see $(\Delta t/\Delta V)$ in [Recommended Operating Conditions](#).
 - For specified high and low levels, see $(V_{IH}$ and $V_{IL})$ in [Recommended Operating Conditions](#).
 - Inputs are overvoltage tolerant allowing them to go as high as $(V_I \text{ max})$ in [Recommended Operating Conditions](#) at any valid V_{CC} .
2. Recommended maximum output conditions:
 - Load currents must not exceed $(I_O \text{ max})$ per output and must not exceed (Continuous current through V_{CC} or GND) total current for the part. These limits are located in [Absolute Maximum Ratings](#).
 - Outputs must not be pulled above V_{CC} .

Typical Application (continued)

9.2.3 Application Curves

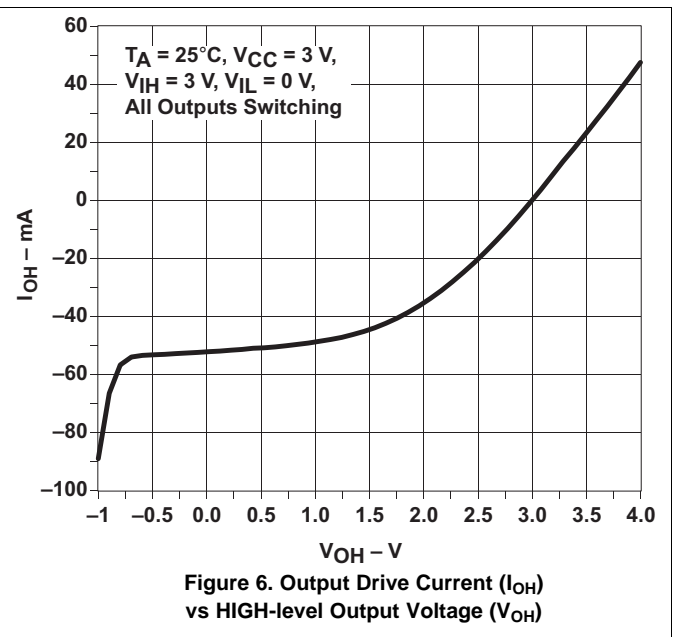
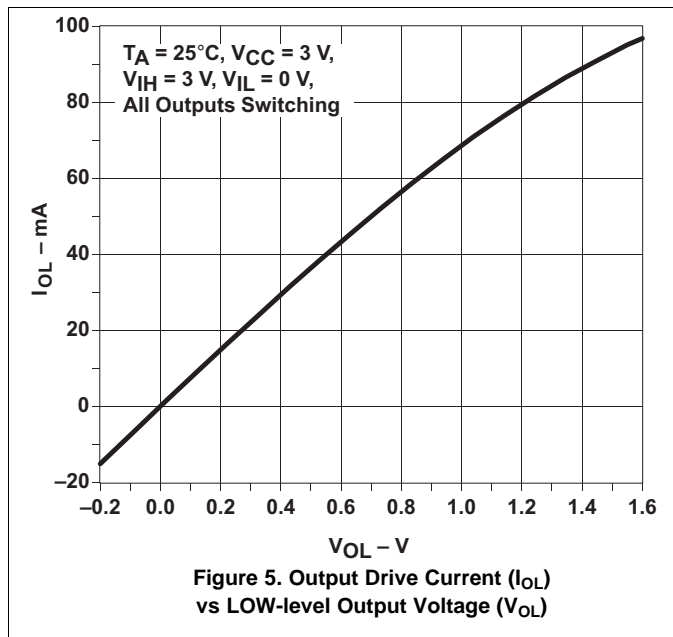

10 Power Supply Recommendations

The power supply may be any voltage between the minimum and maximum supply voltage rating located in [Recommended Operating Conditions](#).

Each V_{CC} terminal must have a good bypass capacitor to prevent power disturbance. A 0.1- μF capacitor is recommended for devices with a single supply. If there are multiple V_{CC} terminals, then 0.01- μF or 0.022- μF capacitors are recommended for each power terminal. It is permissible to parallel multiple bypass capacitors to reject different frequencies of noise. Multiple bypass capacitors may be paralleled to reject different frequencies of noise. The bypass capacitor must be installed as close to the power terminal as possible for the best results.

11 Layout

11.1 Layout Guidelines

Inputs must not float when using multiple bit logic devices. In many cases, functions or parts of functions of digital logic devices are unused. Some examples include situations when only two inputs of a triple-input AND gate are used, or when only 3 of the 4-buffer gates are used. Such input pins must not be left unconnected because the undefined voltages at the outside connections result in undefined operational states.

Specified in [Figure 7](#) are rules that must be observed under all circumstances. All unused inputs of digital logic devices must be connected to a high or low bias to prevent them from floating. The logic level that must be applied to any particular unused input depends on the function of the device. Generally, they are tied to GND or V_{CC} , whichever makes more sense or is more convenient.

11.2 Layout Example

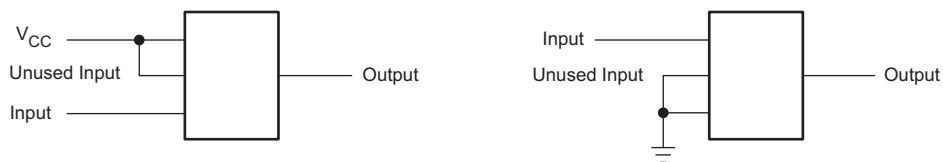

Figure 7. Layout Diagram

12 Device and Documentation Support

12.1 Documentation Support

12.1.1 Related Documentation

For related documentation see the following:

[Implications of Slow or Floating CMOS Inputs](#) (SCBA004)

12.2 Related Links

The table below lists quick access links. Categories include technical documents, support and community resources, tools and software, and quick access to order now.

Table 2. Related Links

PARTS	PRODUCT FOLDER	ORDER NOW	TECHNICAL DOCUMENTS	TOOLS & SOFTWARE	SUPPORT & COMMUNITY
SN54LVC74A	Click here	Click here	Click here	Click here	Click here
SN74LVC74A	Click here	Click here	Click here	Click here	Click here

12.3 Receiving Notification of Documentation Updates

To receive notification of documentation updates, navigate to the device product folder on ti.com. In the upper right corner, click on *Alert me* to register and receive a weekly digest of any product information that has changed. For change details, review the revision history included in any revised document.

12.4 Community Resource

The following links connect to TI community resources. Linked contents are provided "AS IS" by the respective contributors. They do not constitute TI specifications and do not necessarily reflect TI's views; see TI's [Terms of Use](#).

TI E2E™ Online Community *TI's Engineer-to-Engineer (E2E) Community*. Created to foster collaboration among engineers. At e2e.ti.com, you can ask questions, share knowledge, explore ideas and help solve problems with fellow engineers.

Design Support *TI's Design Support* Quickly find helpful E2E forums along with design support tools and contact information for technical support.

12.5 Trademarks

E2E is a trademark of Texas Instruments.

All other trademarks are the property of their respective owners.

12.6 Electrostatic Discharge Caution



These devices have limited built-in ESD protection. The leads should be shorted together or the device placed in conductive foam during storage or handling to prevent electrostatic damage to the MOS gates.

12.7 Glossary

[SLYZ022](#) — *TI Glossary*.

This glossary lists and explains terms, acronyms, and definitions.

13 Mechanical, Packaging, and Orderable Information

The following pages include mechanical, packaging, and orderable information. This information is the most current data available for the designated devices. This data is subject to change without notice and revision of this document. For browser-based versions of this data sheet, refer to the left-hand navigation.

PACKAGING INFORMATION

Orderable Device	Status (1)	Package Type	Package Drawing	Pins	Package Qty	Eco Plan (2)	Lead/Ball Finish (6)	MSL Peak Temp (3)	Op Temp (°C)	Device Marking (4/5)	Samples
5962-9761601Q2A	ACTIVE	LCCC	FK	20	1	TBD	POST-PLATE	N / A for Pkg Type	-55 to 125	5962-9761601Q2A SNJ54LVC74AFK	Samples
5962-9761601QCA	ACTIVE	CDIP	J	14	1	TBD	A42	N / A for Pkg Type	-55 to 125	5962-9761601QC A SNJ54LVC74AJ	Samples
5962-9761601QDA	ACTIVE	CFP	W	14	1	TBD	A42	N / A for Pkg Type	-55 to 125	5962-9761601QD A SNJ54LVC74AW	Samples
5962-9761601VDA	ACTIVE	CFP	W	14	1	TBD	A42	N / A for Pkg Type	-55 to 125	5962-9761601VD A SNV54LVC74AW	Samples
SN74LVC74AD	ACTIVE	SOIC	D	14	50	Green (RoHS & no Sb/Br)	CU NIPDAU	Level-1-260C-UNLIM	-40 to 125	LVC74A	Samples
SN74LVC74ADBR	ACTIVE	SSOP	DB	14	2000	Green (RoHS & no Sb/Br)	CU NIPDAU	Level-1-260C-UNLIM	-40 to 125	LC74A	Samples
SN74LVC74ADBRG4	ACTIVE	SSOP	DB	14	2000	Green (RoHS & no Sb/Br)	CU NIPDAU	Level-1-260C-UNLIM	-40 to 125	LC74A	Samples
SN74LVC74ADE4	ACTIVE	SOIC	D	14	50	Green (RoHS & no Sb/Br)	CU NIPDAU	Level-1-260C-UNLIM	-40 to 125	LVC74A	Samples
SN74LVC74ADR	ACTIVE	SOIC	D	14	2500	Green (RoHS & no Sb/Br)	CU NIPDAU	Level-1-260C-UNLIM	-40 to 125	LVC74A	Samples
SN74LVC74ADRE4	ACTIVE	SOIC	D	14	2500	Green (RoHS & no Sb/Br)	CU NIPDAU	Level-1-260C-UNLIM	-40 to 125	LVC74A	Samples
SN74LVC74ADT	ACTIVE	SOIC	D	14	250	Green (RoHS & no Sb/Br)	CU NIPDAU	Level-1-260C-UNLIM	-40 to 125	LVC74A	Samples
SN74LVC74ANSR	ACTIVE	SO	NS	14	2000	Green (RoHS & no Sb/Br)	CU NIPDAU	Level-1-260C-UNLIM	-40 to 125	LVC74A	Samples
SN74LVC74APW	ACTIVE	TSSOP	PW	14	90	Green (RoHS & no Sb/Br)	CU NIPDAU	Level-1-260C-UNLIM	-40 to 125	LC74A	Samples
SN74LVC74APWG4	ACTIVE	TSSOP	PW	14	90	Green (RoHS & no Sb/Br)	CU NIPDAU	Level-1-260C-UNLIM	-40 to 125	LC74A	Samples
SN74LVC74APWR	ACTIVE	TSSOP	PW	14	2000	Green (RoHS & no Sb/Br)	CU NIPDAU CU SN	Level-1-260C-UNLIM	-40 to 125	LC74A	Samples

Orderable Device	Status (1)	Package Type	Package Drawing	Pins	Package Qty	Eco Plan (2)	Lead/Ball Finish (6)	MSL Peak Temp (3)	Op Temp (°C)	Device Marking (4/5)	Samples
SN74LVC74APWRE4	ACTIVE	TSSOP	PW	14	2000	Green (RoHS & no Sb/Br)	CU NIPDAU	Level-1-260C-UNLIM	-40 to 125	LC74A	Samples
SN74LVC74APWRG4	ACTIVE	TSSOP	PW	14	2000	Green (RoHS & no Sb/Br)	CU NIPDAU	Level-1-260C-UNLIM	-40 to 125	LC74A	Samples
SN74LVC74APWT	ACTIVE	TSSOP	PW	14	250	Green (RoHS & no Sb/Br)	CU NIPDAU	Level-1-260C-UNLIM	-40 to 125	LC74A	Samples
SN74LVC74APWTG4	ACTIVE	TSSOP	PW	14	250	Green (RoHS & no Sb/Br)	CU NIPDAU	Level-1-260C-UNLIM	-40 to 125	LC74A	Samples
SN74LVC74ARGYR	ACTIVE	VQFN	RGY	14	3000	Green (RoHS & no Sb/Br)	CU NIPDAU	Level-2-260C-1 YEAR	-40 to 125	LC74A	Samples
SNJ54LVC74AFK	ACTIVE	LCCC	FK	20	1	TBD	POST-PLATE	N / A for Pkg Type	-55 to 125	5962-9761601Q2A SNJ54LVC74AFK	Samples
SNJ54LVC74AJ	ACTIVE	CDIP	J	14	1	TBD	A42	N / A for Pkg Type	-55 to 125	5962-9761601QC A SNJ54LVC74AJ	Samples
SNJ54LVC74AW	ACTIVE	CFP	W	14	1	TBD	A42	N / A for Pkg Type	-55 to 125	5962-9761601QD A SNJ54LVC74AW	Samples

(1) The marketing status values are defined as follows:

ACTIVE: Product device recommended for new designs.

LIFEBUY: TI has announced that the device will be discontinued, and a lifetime-buy period is in effect.

NRND: Not recommended for new designs. Device is in production to support existing customers, but TI does not recommend using this part in a new design.

PREVIEW: Device has been announced but is not in production. Samples may or may not be available.

OBSOLETE: TI has discontinued the production of the device.

(2) **RoHS:** TI defines "RoHS" to mean semiconductor products that are compliant with the current EU RoHS requirements for all 10 RoHS substances, including the requirement that RoHS substance do not exceed 0.1% by weight in homogeneous materials. Where designed to be soldered at high temperatures, "RoHS" products are suitable for use in specified lead-free processes. TI may reference these types of products as "Pb-Free".

RoHS Exempt: TI defines "RoHS Exempt" to mean products that contain lead but are compliant with EU RoHS pursuant to a specific EU RoHS exemption.

Green: TI defines "Green" to mean the content of Chlorine (Cl) and Bromine (Br) based flame retardants meet JS709B low halogen requirements of <=1000ppm threshold. Antimony trioxide based flame retardants must also meet the <=1000ppm threshold requirement.

(3) MSL, Peak Temp. - The Moisture Sensitivity Level rating according to the JEDEC industry standard classifications, and peak solder temperature.

(4) There may be additional marking, which relates to the logo, the lot trace code information, or the environmental category on the device.

⁽⁵⁾ Multiple Device Markings will be inside parentheses. Only one Device Marking contained in parentheses and separated by a "~" will appear on a device. If a line is indented then it is a continuation of the previous line and the two combined represent the entire Device Marking for that device.

⁽⁶⁾ Lead/Ball Finish - Orderable Devices may have multiple material finish options. Finish options are separated by a vertical ruled line. Lead/Ball Finish values may wrap to two lines if the finish value exceeds the maximum column width.

Important Information and Disclaimer: The information provided on this page represents TI's knowledge and belief as of the date that it is provided. TI bases its knowledge and belief on information provided by third parties, and makes no representation or warranty as to the accuracy of such information. Efforts are underway to better integrate information from third parties. TI has taken and continues to take reasonable steps to provide representative and accurate information but may not have conducted destructive testing or chemical analysis on incoming materials and chemicals. TI and TI suppliers consider certain information to be proprietary, and thus CAS numbers and other limited information may not be available for release.

In no event shall TI's liability arising out of such information exceed the total purchase price of the TI part(s) at issue in this document sold by TI to Customer on an annual basis.

OTHER QUALIFIED VERSIONS OF SN54LVC74A, SN54LVC74A-SP, SN74LVC74A :

- Catalog: [SN74LVC74A](#), [SN54LVC74A](#)
- Automotive: [SN74LVC74A-Q1](#), [SN74LVC74A-Q1](#)
- Enhanced Product: [SN74LVC74A-EP](#), [SN74LVC74A-EP](#)
- Military: [SN54LVC74A](#)
- Space: [SN54LVC74A-SP](#)

NOTE: Qualified Version Definitions:

- Catalog - TI's standard catalog product
- Automotive - Q100 devices qualified for high-reliability automotive applications targeting zero defects
- Enhanced Product - Supports Defense, Aerospace and Medical Applications
- Military - QML certified for Military and Defense Applications
- Space - Radiation tolerant, ceramic packaging and qualified for use in Space-based application

TAPE AND REEL INFORMATION

QUADRANT ASSIGNMENTS FOR PIN 1 ORIENTATION IN TAPE

*All dimensions are nominal

Device	Package Type	Package Drawing	Pins	SPQ	Reel Diameter (mm)	Reel Width W1 (mm)	A0 (mm)	B0 (mm)	K0 (mm)	P1 (mm)	W (mm)	Pin1 Quadrant
SN74LVC74ADR	SOIC	D	14	2500	330.0	16.4	6.5	9.0	2.1	8.0	16.0	Q1
SN74LVC74ADT	SOIC	D	14	250	330.0	16.4	6.5	9.0	2.1	8.0	16.0	Q1
SN74LVC74ANSR	SO	NS	14	2000	330.0	16.4	8.2	10.5	2.5	12.0	16.0	Q1
SN74LVC74APWR	TSSOP	PW	14	2000	330.0	12.4	6.9	5.6	1.6	8.0	12.0	Q1
SN74LVC74APWR	TSSOP	PW	14	2000	330.0	12.4	6.9	5.6	1.6	8.0	12.0	Q1
SN74LVC74APWRG4	TSSOP	PW	14	2000	330.0	12.4	6.9	5.6	1.6	8.0	12.0	Q1
SN74LVC74APWT	TSSOP	PW	14	250	330.0	12.4	6.9	5.6	1.6	8.0	12.0	Q1

TAPE AND REEL BOX DIMENSIONS

*All dimensions are nominal

Device	Package Type	Package Drawing	Pins	SPQ	Length (mm)	Width (mm)	Height (mm)
SN74LVC74ADR	SOIC	D	14	2500	367.0	367.0	38.0
SN74LVC74ADT	SOIC	D	14	250	210.0	185.0	35.0
SN74LVC74ANSR	SO	NS	14	2000	367.0	367.0	38.0
SN74LVC74APWR	TSSOP	PW	14	2000	364.0	364.0	27.0
SN74LVC74APWR	TSSOP	PW	14	2000	367.0	367.0	35.0
SN74LVC74APWRG4	TSSOP	PW	14	2000	367.0	367.0	35.0
SN74LVC74APWT	TSSOP	PW	14	250	367.0	367.0	35.0

FK (S-CQCC-N**)

LEADLESS CERAMIC CHIP CARRIER

28 TERMINAL SHOWN



NO. OF TERMINALS **	A		B	
	MIN	MAX	MIN	MAX
20	0.342 (8,69)	0.358 (9,09)	0.307 (7,80)	0.358 (9,09)
28	0.442 (11,23)	0.458 (11,63)	0.406 (10,31)	0.458 (11,63)
44	0.640 (16,26)	0.660 (16,76)	0.495 (12,58)	0.560 (14,22)
52	0.740 (18,78)	0.761 (19,32)	0.495 (12,58)	0.560 (14,22)
68	0.938 (23,83)	0.962 (24,43)	0.850 (21,6)	0.858 (21,8)
84	1.141 (28,99)	1.165 (29,59)	1.047 (26,6)	1.063 (27,0)



4040140/D 01/11

- NOTES:
- All linear dimensions are in inches (millimeters).
 - This drawing is subject to change without notice.
 - This package can be hermetically sealed with a metal lid.
 - Falls within JEDEC MS-004

RGY (S-PVQFN-N14)

PLASTIC QUAD FLATPACK NO-LEAD



- NOTES:
- A. All linear dimensions are in millimeters. Dimensioning and tolerancing per ASME Y14.5M-1994.
 - B. This drawing is subject to change without notice.
 - C. QFN (Quad Flatpack No-Lead) package configuration.
 - D. The package thermal pad must be soldered to the board for thermal and mechanical performance.
 - E. See the additional figure in the Product Data Sheet for details regarding the exposed thermal pad features and dimensions.
 - F** Pin 1 identifiers are located on both top and bottom of the package and within the zone indicated. The Pin 1 identifiers are either a molded, marked, or metal feature.
 - G. Package complies to JEDEC MO-241 variation BA.

RGY (S-PVQFN-N14)

PLASTIC QUAD FLATPACK NO-LEAD

THERMAL INFORMATION

This package incorporates an exposed thermal pad that is designed to be attached directly to an external heatsink. The thermal pad must be soldered directly to the printed circuit board (PCB). After soldering, the PCB can be used as a heatsink. In addition, through the use of thermal vias, the thermal pad can be attached directly to the appropriate copper plane shown in the electrical schematic for the device, or alternatively, can be attached to a special heatsink structure designed into the PCB. This design optimizes the heat transfer from the integrated circuit (IC).

For information on the Quad Flatpack No-Lead (QFN) package and its advantages, refer to Application Report, QFN/SON PCB Attachment, Texas Instruments Literature No. SLUA271. This document is available at www.ti.com.

The exposed thermal pad dimensions for this package are shown in the following illustration.



Bottom View

Exposed Thermal Pad Dimensions

4206353-2/P 03/14

NOTE: All linear dimensions are in millimeters

RGY (S-PVQFN-N14)

PLASTIC QUAD FLATPACK NO-LEAD



4208122-2/P 03/14

- NOTES:
- All linear dimensions are in millimeters.
 - This drawing is subject to change without notice.
 - Publication IPC-7351 is recommended for alternate designs.
 - This package is designed to be soldered to a thermal pad on the board. Refer to Application Note, Quad Flat-Pack QFN/SON PCB Attachment, Texas Instruments Literature No. SLUA271, and also the Product Data Sheets for specific thermal information, via requirements, and recommended board layout. These documents are available at www.ti.com <<http://www.ti.com>>.
 - Laser cutting apertures with trapezoidal walls and also rounding corners will offer better paste release. Customers should contact their board assembly site for stencil design recommendations. Refer to IPC 7525 for stencil design considerations.
 - Customers should contact their board fabrication site for minimum solder mask web tolerances between signal pads.

MECHANICAL DATA

NS (R-PDSO-G**)

PLASTIC SMALL-OUTLINE PACKAGE

14-PINS SHOWN



- NOTES:
- A. All linear dimensions are in millimeters.
 - B. This drawing is subject to change without notice.
 - C. Body dimensions do not include mold flash or protrusion, not to exceed 0,15.

J 14

GENERIC PACKAGE VIEW
CDIP - 5.08 mm max height
CERAMIC DUAL IN LINE PACKAGE

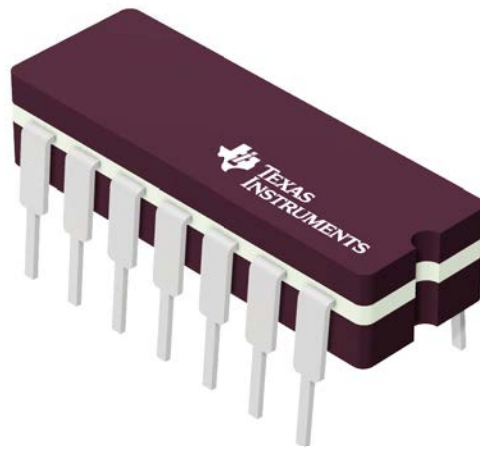

Images above are just a representation of the package family, actual package may vary.
Refer to the product data sheet for package details.

4040083-5/G

J0014A



PACKAGE OUTLINE

CDIP - 5.08 mm max height

CERAMIC DUAL IN LINE PACKAGE



4214771/A 05/2017

NOTES:

1. All controlling linear dimensions are in inches. Dimensions in brackets are in millimeters. Any dimension in brackets or parenthesis are for reference only. Dimensioning and tolerancing per ASME Y14.5M.
2. This drawing is subject to change without notice.
3. This package is hermetically sealed with a ceramic lid using glass frit.
4. Index point is provided on cap for terminal identification only and on press ceramic glass frit seal only.
5. Falls within MIL-STD-1835 and GDIP1-T14.

EXAMPLE BOARD LAYOUT

J0014A

CDIP - 5.08 mm max height

CERAMIC DUAL IN LINE PACKAGE



LAND PATTERN EXAMPLE
NON-SOLDER MASK DEFINED
SCALE: 5X



4214771/A 05/2017

D (R-PDSO-G14)

PLASTIC SMALL OUTLINE



4211283-3/E 08/12

- NOTES:
- A. All linear dimensions are in millimeters.
 - B. This drawing is subject to change without notice.
 - C. Publication IPC-7351 is recommended for alternate designs.
 - D. Laser cutting apertures with trapezoidal walls and also rounding corners will offer better paste release. Customers should contact their board assembly site for stencil design recommendations. Refer to IPC-7525 for other stencil recommendations.
 - E. Customers should contact their board fabrication site for solder mask tolerances between and around signal pads.

PW (R-PDSO-G14)

PLASTIC SMALL OUTLINE



4211284-2/G 08/15

- NOTES:
- All linear dimensions are in millimeters.
 - This drawing is subject to change without notice.
 - Publication IPC-7351 is recommended for alternate designs.
 - Laser cutting apertures with trapezoidal walls and also rounding corners will offer better paste release. Customers should contact their board assembly site for stencil design recommendations. Refer to IPC-7525 for other stencil recommendations.
 - Customers should contact their board fabrication site for solder mask tolerances between and around signal pads.

DB (R-PDSO-G**)

PLASTIC SMALL-OUTLINE

28 PINS SHOWN



- NOTES: A. All linear dimensions are in millimeters.
 B. This drawing is subject to change without notice.
 C. Body dimensions do not include mold flash or protrusion not to exceed 0,15.
 D. Falls within JEDEC MO-150

W (R-GDFP-F14)

CERAMIC DUAL FLATPACK

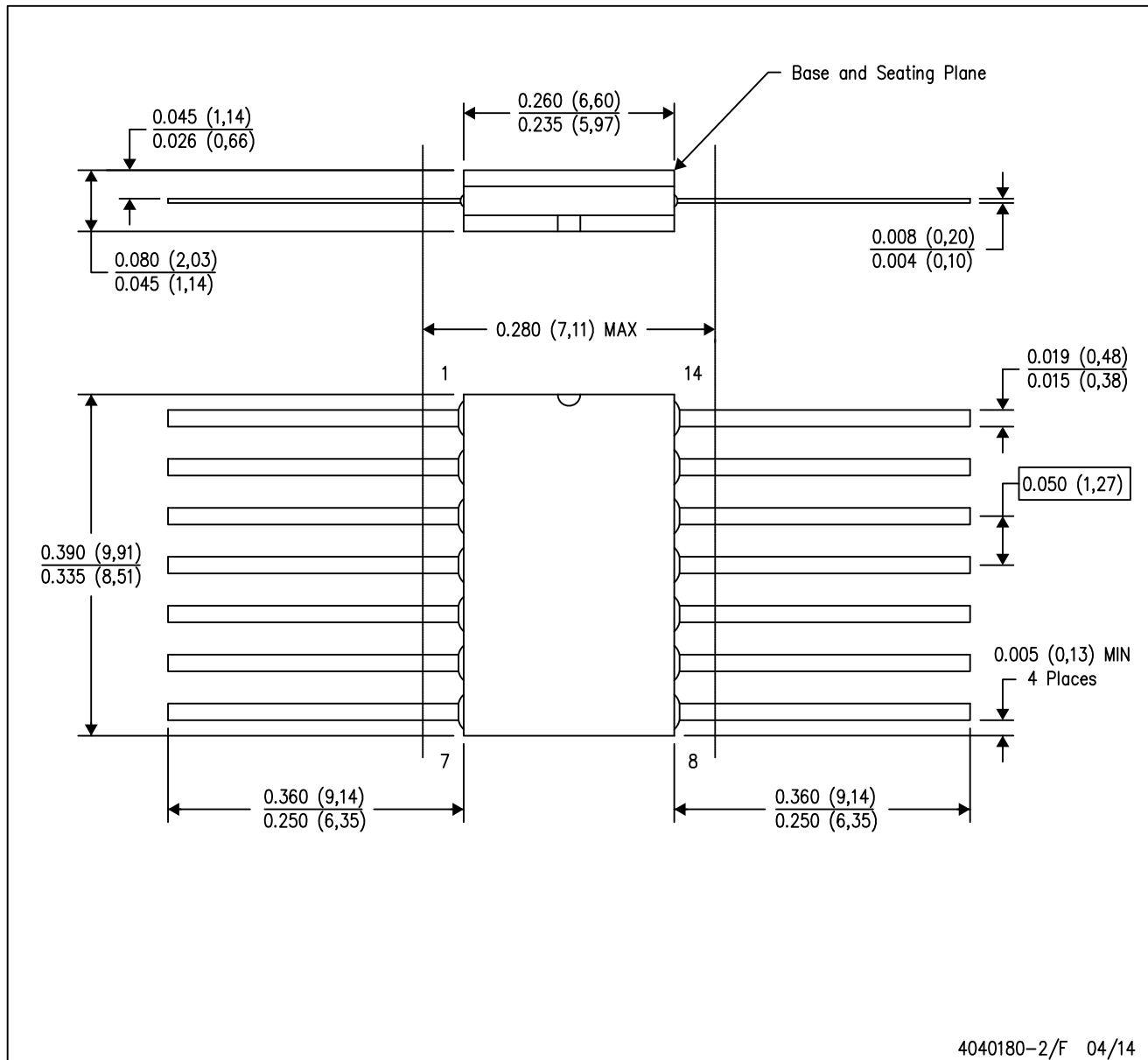

- NOTES:
- A. All linear dimensions are in inches (millimeters).
 - B. This drawing is subject to change without notice.
 - C. This package can be hermetically sealed with a ceramic lid using glass frit.
 - D. Index point is provided on cap for terminal identification only.
 - E. Falls within MIL STD 1835 GDFP1-F14

IMPORTANT NOTICE AND DISCLAIMER

TI PROVIDES TECHNICAL AND RELIABILITY DATA (INCLUDING DATASHEETS), DESIGN RESOURCES (INCLUDING REFERENCE DESIGNS), APPLICATION OR OTHER DESIGN ADVICE, WEB TOOLS, SAFETY INFORMATION, AND OTHER RESOURCES "AS IS" AND WITH ALL FAULTS, AND DISCLAIMS ALL WARRANTIES, EXPRESS AND IMPLIED, INCLUDING WITHOUT LIMITATION ANY IMPLIED WARRANTIES OF MERCHANTABILITY, FITNESS FOR A PARTICULAR PURPOSE OR NON-INFRINGEMENT OF THIRD PARTY INTELLECTUAL PROPERTY RIGHTS.



These resources are intended for skilled developers designing with TI products. You are solely responsible for (1) selecting the appropriate TI products for your application, (2) designing, validating and testing your application, and (3) ensuring your application meets applicable standards, and any other safety, security, or other requirements. These resources are subject to change without notice. TI grants you permission to use these resources only for development of an application that uses the TI products described in the resource. Other reproduction and display of these resources is prohibited. No license is granted to any other TI intellectual property right or to any third party intellectual property right. TI disclaims responsibility for, and you will fully indemnify TI and its representatives against, any claims, damages, costs, losses, and liabilities arising out of your use of these resources.

TI's products are provided subject to TI's Terms of Sale (www.ti.com/legal/termsofsale.html) or other applicable terms available either on ti.com or provided in conjunction with such TI products. TI's provision of these resources does not expand or otherwise alter TI's applicable warranties or warranty disclaimers for TI products.

Mailing Address: Texas Instruments, Post Office Box 655303, Dallas, Texas 75265
Copyright © 2018, Texas Instruments Incorporated

Looking for pricing, stock, or lifecycle information?

Click below to explore more details on WIN SOURCE:

-  [View SN74LVC74ADBR on WIN SOURCE](#)
-  [Texas Instruments](#) Information

Optimize Your Supply Chain with WIN SOURCE Solutions

-  Global Sourcing Solution
-  Obsolete Management
-  Cost Control Management
-  Shortage Management
-  Alternative Solution
-  Excess Inventory Management