



THE DATASHEET OF 74HC4520N



74HC4520; 74HCT4520

Dual 4-bit synchronous binary counter

Rev. 3 — 4 December 2014

Product data sheet

1. General description

The 74HC4520; 74HCT4520 are dual 4-bit internally synchronous binary counters with two clock inputs ($nCP0$ and $n\overline{CP1}$). They have buffered outputs from all 4 bit positions ($nQ0$ to $nQ3$) and an asynchronous master reset input (nMR). The counter advances on the LOW-to-HIGH transition of $nCP0$ when $n\overline{CP1}$ is HIGH. It also advances on the HIGH-to-LOW transition of $n\overline{CP1}$ when $nCP0$ is LOW. Either $nCP0$ or $n\overline{CP1}$ may be used as the clock input to the counter. The other clock input may be used as a clock enable input. A HIGH on nMR , resets the counter ($nQ0$ to $nQ3 = \text{LOW}$) independent of $nCP0$ and $n\overline{CP1}$. Inputs include clamp diodes. It enables the use of current limiting resistors to interface inputs to voltages in excess of V_{CC} .

2. Features and benefits

- Complies with JEDEC standard no. 7A
- Input levels:
 - ◆ For 74HC4520: CMOS level
 - ◆ For 74HCT4520: TTL level
- ESD protection:
 - ◆ HBM JESD22-A114F exceeds 2000 V
 - ◆ MM JESD22-A115-A exceeds 200 V
- Multiple package options
- Specified from $-40\text{ }^{\circ}\text{C}$ to $+85\text{ }^{\circ}\text{C}$ and $-40\text{ }^{\circ}\text{C}$ to $+125\text{ }^{\circ}\text{C}$

3. Applications

- Multistage synchronous counting
- Multistage asynchronous counting
- Frequency dividers



4. Ordering information

Table 1. Ordering information

Type number	Package			Version
	Temperature range	Name	Description	
74HC4520N	-40 °C to +125 °C	DIP16	plastic dual in-line package; 16 leads (300 mil)	SOT38-4
74HCT4520N				
74HC4520D	-40 °C to +125 °C	SO16	plastic small outline package; 16 leads; body width 3.9 mm	SOT109-1
74HCT4520D				
74HC4520DB	-40 °C to +125 °C	SSOP16	plastic shrink small outline package; 16 leads; body width 5.3 mm	SOT338-1
74HCT4520DB				
74HC4520PW	-40 °C to +125 °C	TSSOP16	plastic thin shrink small outline package; 16 leads; body width 4.4 mm	SOT403-1

5. Functional diagram

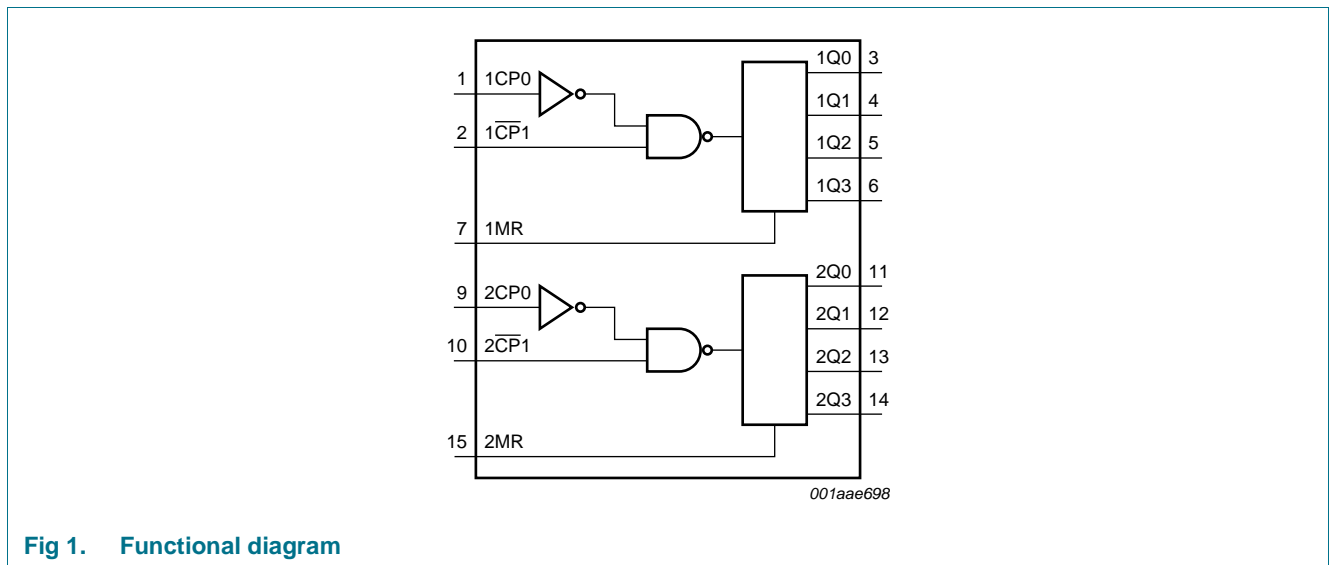

Fig 1. Functional diagram

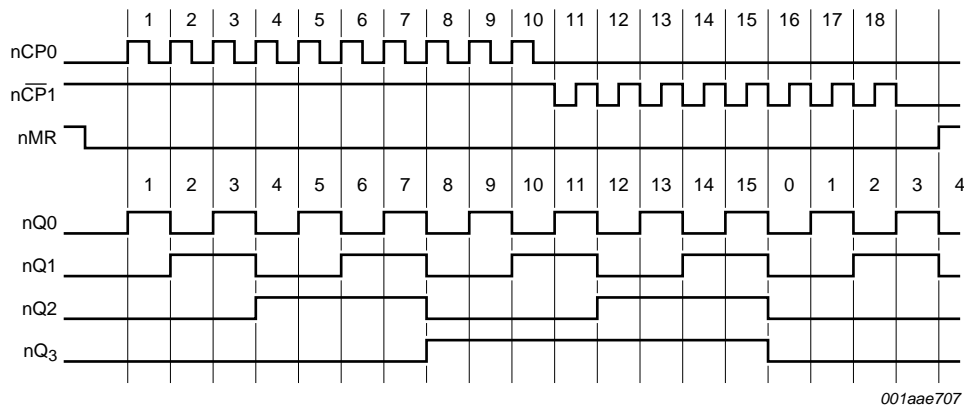

Fig 2. Timing diagram

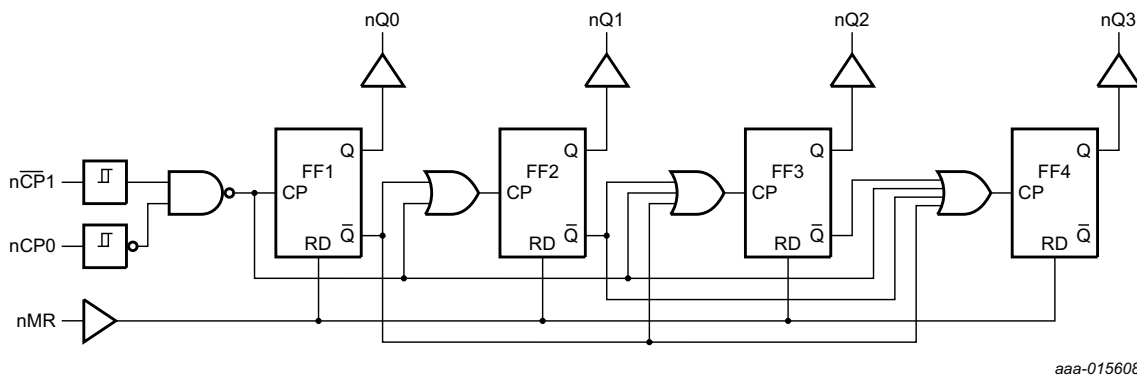
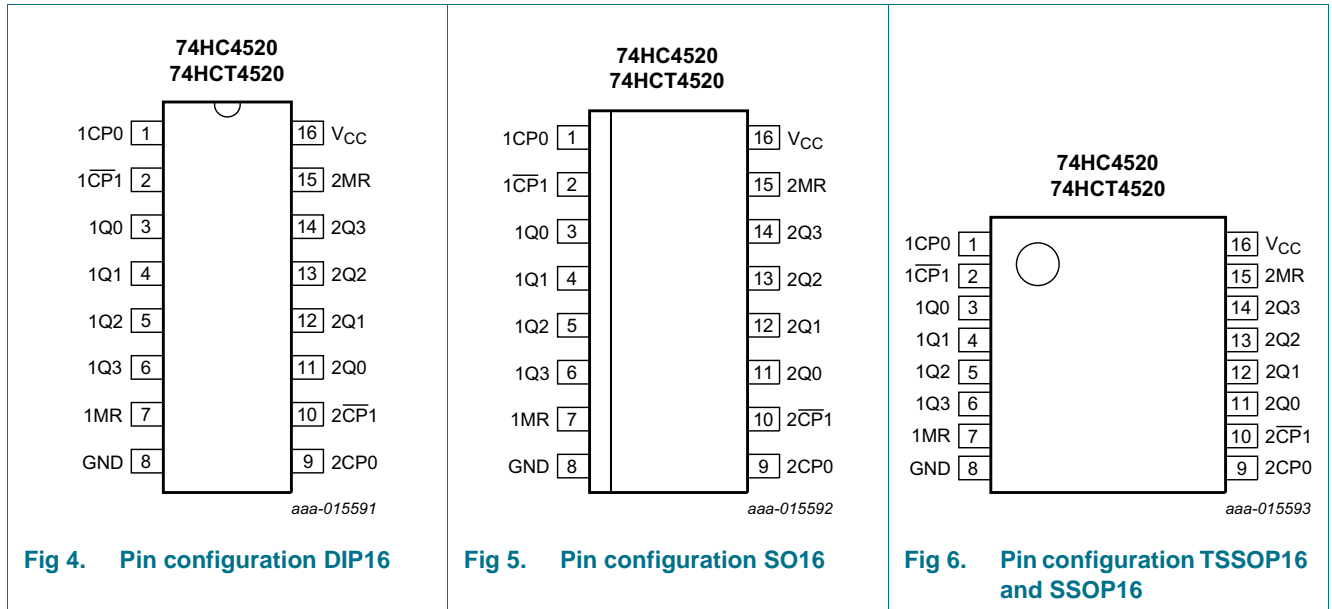

Fig 3. Logic diagram for one counter

6. Pinning information

6.1 Pinning



6.2 Pin description

Table 2. Pin description

Symbol	Pin	Description
1CP0, 2CP0	1, 9	clock input (LOW-to-HIGH edge-triggered)
1CP1, 2CP1	2, 10	clock input (HIGH-to-LOW edge-triggered)
1Q0 to 1Q3	3, 4, 5, 6	output
1MR, 2MR	7, 15	asynchronous master reset input (active HIGH)
GND	8	ground (0 V)
2Q0 to 2Q3	11, 12, 13, 14	output
V _{CC}	16	supply voltage

7. Functional description

Table 3. Function table^[1]

nCP0	nCP1	nMR	Mode
↑	H	L	counter advances
L	↓	L	counter advances
↓	X	L	no change
X	↑	L	no change
↑	L	L	no change
H	↓	L	no change
X	X	H	nQ0 to nQ3 = LOW

[1] H = HIGH voltage level; L = LOW voltage level; X = don't care; ↑ = positive-going transition; ↓ = negative-going transition.

8. Limiting values

Table 4. Limiting values

In accordance with the Absolute Maximum Rating System (IEC 60134). Voltages are referenced to GND (ground = 0 V).

Symbol	Parameter	Conditions	Min	Max	Unit
V_{CC}	supply voltage		-0.5	+7.0	V
I_{IK}	input clamping current	$V_I < -0.5\text{ V}$ or $V_I > V_{CC} + 0.5\text{ V}$	-	±20	mA
I_{OK}	output clamping current	$V_O < -0.5\text{ V}$ or $V_O > V_{CC} + 0.5\text{ V}$	-	±20	mA
I_O	output current	$V_O = -0.5\text{ V}$ to $V_{CC} + 0.5\text{ V}$	-	±25	mA
I_{CC}	supply current		-	50	mA
I_{GND}	ground current		-50	-	mA
T_{stg}	storage temperature		-65	+150	°C
P_{tot}	total power dissipation	DIP16 package ^[1]	-	750	mW
		SO16 package ^[1]	-	500	mW
		(T)SSOP16 package ^[1]	-	500	mW

[1] For DIP16 packages: above 70 °C the value of P_{tot} derates linearly at 12 mW/K.
 For SO16 packages: above 70 °C the value of P_{tot} derates linearly at 8 mW/K.
 For (T)SSOP16 packages: above 60 °C the value of P_{tot} derates linearly at 5.5 mW/K.

9. Recommended operating conditions

Table 5. Recommended operating conditions

Voltages are referenced to GND (ground = 0 V)

Symbol	Parameter	Conditions	74HC4520			74HCT4520			Unit
			Min	Typ	Max	Min	Typ	Max	
V _{CC}	supply voltage		2.0	5.0	6.0	4.5	5.0	5.5	V
V _I	input voltage		0	-	V _{CC}	0	-	V _{CC}	V
V _O	output voltage		0	-	V _{CC}	0	-	V _{CC}	V
T _{amb}	ambient temperature		-40	+25	+125	-40	+25	+125	°C
Δt/ΔV	input transition rise and fall rate	V _{CC} = 2.0 V	-	-	625	-	-	-	ns/V
		V _{CC} = 4.5 V	-	1.67	139	-	1.67	139	ns/V
		V _{CC} = 6.0 V	-	-	83	-	-	-	ns/V

10. Static characteristics

Table 6. Static characteristics

At recommended operating conditions; voltages are referenced to GND (ground = 0 V).

Symbol	Parameter	Conditions	25 °C			-40 °C to +85 °C		-40 °C to +125 °C		Unit
			Min	Typ	Max	Min	Max	Min	Max	
74HC4520										
V _{IH}	HIGH-level input voltage	V _{CC} = 2.0 V	1.5	1.2	-	1.5	-	1.5	-	V
		V _{CC} = 4.5 V	3.15	2.4	-	3.15	-	3.15	-	V
		V _{CC} = 6.0 V	4.2	3.2	-	4.2	-	4.2	-	V
V _{IL}	LOW-level input voltage	V _{CC} = 2.0 V	-	0.8	0.5	-	0.5	-	0.5	V
		V _{CC} = 4.5 V	-	2.1	1.35	-	1.35	-	1.35	V
		V _{CC} = 6.0 V	-	2.8	1.8	-	1.8	-	1.8	V
V _{OH}	HIGH-level output voltage	V _I = V _{IH} or V _{IL}								
		I _O = -20 μA; V _{CC} = 2.0 V	1.9	2.0	-	1.9	-	1.9	-	V
		I _O = -20 μA; V _{CC} = 4.5 V	4.4	4.5	-	4.4	-	4.4	-	V
		I _O = -20 μA; V _{CC} = 6.0 V	5.9	6.0	-	5.9	-	5.9	-	V
		I _O = -4.0; V _{CC} = 4.5 V	3.98	4.32	-	3.84	-	3.7	-	V
I _O = -5.2; V _{CC} = 6.0 V	5.48	5.81	-	5.34	-	5.2	-	V		
V _{OL}	LOW-level output voltage	V _I = V _{IH} or V _{IL}								
		I _O = 20 μA; V _{CC} = 2.0 V	-	0	0.1	-	0.1	-	0.1	V
		I _O = 20 μA; V _{CC} = 4.5 V	-	0	0.1	-	0.1	-	0.1	V
		I _O = 20 μA; V _{CC} = 6.0 V	-	0	0.1	-	0.1	-	0.1	V
		I _O = 4.0 mA; V _{CC} = 4.5 V	-	0.15	0.26	-	0.33	-	0.4	V
I _O = 5.2 mA; V _{CC} = 6.0 V	-	0.16	0.26	-	0.33	-	0.4	V		
I _I	input leakage current	V _I = V _{CC} or GND; V _{CC} = 6.0 V	-	-	±0.1	-	±1.0	-	±1.0	μA
I _{CC}	supply current	V _I = V _{CC} or GND; I _O = 0 A; V _{CC} = 6.0 V	-	-	8.0	-	80.0	-	160.0	μA

Table 6. Static characteristics ...continued

At recommended operating conditions; voltages are referenced to GND (ground = 0 V).

Symbol	Parameter	Conditions	25 °C			-40 °C to +85 °C		-40 °C to +125 °C		Unit
			Min	Typ	Max	Min	Max	Min	Max	
C _I	input capacitance		-	3.5	-	-	-	-	-	pF
74HCT4520										
V _{IH}	HIGH-level input voltage	V _{CC} = 4.5 V to 5.5 V	2.0	1.6	-	2.0	-	2.0	-	V
V _{IL}	LOW-level input voltage	V _{CC} = 4.5 V to 5.5 V	-	1.2	0.8	-	0.8	-	0.8	V
V _{OH}	HIGH-level output voltage	V _I = V _{IH} or V _{IL} ; V _{CC} = 4.5 V								
		I _O = -20 μA	4.4	4.5	-	4.4	-	4.4	-	V
		I _O = -4.0 mA	3.98	4.32	-	3.84	-	3.7	-	V
V _{OL}	LOW-level output voltage	V _I = V _{IH} or V _{IL} ; V _{CC} = 4.5 V								
		I _O = 20 μA	-	0	0.1	-	0.1	-	0.1	V
		I _O = 4.0 mA	-	0.15	0.26	-	0.33	-	0.4	V
I _I	input leakage current	V _I = V _{CC} or GND; V _{CC} = 5.5 V	-	-	±0.1	-	±1.0	-	±1.0	μA
I _{CC}	supply current	V _I = V _{CC} or GND; I _O = 0 A; V _{CC} = 5.5 V	-	-	8.0	-	80.0	-	160.0	μA
ΔI _{CC}	additional supply current	per input pin; V _I = V _{CC} - 2.1 V; other inputs at V _{CC} or GND; V _{CC} = 4.5 V to 5.5 V; I _O = 0 A								
		pin nCP0, nCP1	-	80	288	-	360	-	392	μA
		pin nMR	-	150	540	-	675	-	735	μA
C _I	input capacitance		-	3.5	-	-	-	-	-	pF

11. Dynamic characteristics

Table 7. Dynamic characteristics

Voltages are referenced to GND (ground = 0 V); C_L = 50 pF unless otherwise specified; for test circuit, see [Figure 8](#).

Symbol	Parameter	Conditions	25 °C			-40 °C to +85 °C		-40 °C to +125 °C		Unit
			Min	Typ	Max	Min	Max	Min	Max	
74HC4520										
t _{pd}	propagation delay	nCP0 to nQn; see Figure 7 ^[1]								
		V _{CC} = 2.0 V	-	77	240	-	300	-	360	ns
		V _{CC} = 4.5 V	-	28	48	-	60	-	72	ns
		V _{CC} = 5.0 V; C _L = 15 pF	-	24	-	-	-	-	-	ns
		V _{CC} = 6.0 V	-	22	41	-	51	-	61	ns
		nCP1 to nQn; see Figure 7 ^[1]								
		V _{CC} = 2.0 V	-	77	240	-	300	-	360	ns
		V _{CC} = 4.5 V	-	28	48	-	60	-	72	ns
		V _{CC} = 5.0 V; C _L = 15 pF	-	24	-	-	-	-	-	ns
V _{CC} = 6.0 V	-	22	41	-	51	-	61	ns		

Table 7. Dynamic characteristics ...continued

Voltages are referenced to GND (ground = 0 V); $C_L = 50$ pF unless otherwise specified; for test circuit, see [Figure 8](#).

Symbol	Parameter	Conditions	25 °C			-40 °C to +85 °C		-40 °C to +125 °C		Unit
			Min	Typ	Max	Min	Max	Min	Max	
t _{PHL}	HIGH to LOW propagation delay	nMR to nQn; see Figure 7								
		V _{CC} = 2.0 V	-	44	150	-	190	-	225	ns
		V _{CC} = 4.5 V	-	16	30	-	38	-	45	ns
		V _{CC} = 5.0 V; C _L = 15 pF	-	13	-	-	-	-	-	ns
		V _{CC} = 6.0 V	-	13	26	-	33	-	38	ns
t _t	transition time	nQn; see Figure 7 [2]								
		V _{CC} = 2.0 V	-	19	75	-	95	-	110	ns
		V _{CC} = 4.5 V	-	7	15	-	19	-	22	ns
		V _{CC} = 6.0 V	-	6	13	-	16	-	19	ns
t _w	pulse width	nCP0, nCP1 HIGH or LOW; see Figure 7								
		V _{CC} = 2.0 V	80	22	-	100	-	120	-	ns
		V _{CC} = 4.5 V	16	8	-	20	-	24	-	ns
		V _{CC} = 6.0 V	14	6	-	17	-	20	-	ns
		nMR HIGH; see Figure 7								
		V _{CC} = 2.0 V	120	39	-	150	-	180	-	ns
		V _{CC} = 4.5 V	24	14	-	30	-	36	-	ns
		V _{CC} = 6.0 V	20	11	-	26	-	31	-	ns
t _{rec}	recovery time	nMR to nCP0, nCP1; see Figure 7								
		V _{CC} = 2.0 V	0	-28	-	0	-	0	-	ns
		V _{CC} = 4.5 V	0	-10	-	0	-	0	-	ns
		V _{CC} = 6.0 V	0	-8	-	0	-	0	-	ns
t _{su}	set-up time	nCP0 to nCP1; nCP1 to nCP0; see Figure 7								
		V _{CC} = 2.0 V	80	14	-	100	-	120	-	ns
		V _{CC} = 4.5 V	16	5	-	20	-	24	-	ns
		V _{CC} = 6.0 V	14	4	-	17	-	20	-	ns
f _{max}	maximum frequency	nCP0, nCP1; see Figure 7								
		V _{CC} = 2.0 V	6	19	-	4.8	-	4	-	MHz
		V _{CC} = 4.5 V	30	58	-	24	-	20	-	MHz
		V _{CC} = 5.0 V; C _L = 15 pF	-	68	-	-	-	-	-	MHz
		V _{CC} = 6.0 V	35	69	-	28	-	24	-	MHz
C _{PD}	power dissipation capacitance	V _I = GND to V _{CC} ; V _{CC} = 5 V; f _i = 1 MHz [3]	-	29	-	-	-	-	-	pF

74HCT4520

t _{pd}	propagation delay	nCP0 to nQn; see Figure 7 [1]								
		V _{CC} = 4.5 V	-	28	53	-	66	-	80	ns
		V _{CC} = 5.0 V; C _L = 15 pF	-	24	-	-	-	-	-	ns
		nCP1 to nQn; see Figure 7 [1]								
		V _{CC} = 4.5 V	-	25	53	-	66	-	80	ns
		V _{CC} = 5.0 V; C _L = 15 pF	-	24	-	-	-	-	ns	

Table 7. Dynamic characteristics ...continued

Voltages are referenced to GND (ground = 0 V); C_L = 50 pF unless otherwise specified; for test circuit, see [Figure 8](#).

Symbol	Parameter	Conditions	25 °C			-40 °C to +85 °C		-40 °C to +125 °C		Unit
			Min	Typ	Max	Min	Max	Min	Max	
t _{PHL}	HIGH to LOW propagation delay	nMR to nQn; see Figure 7								
		V _{CC} = 4.5 V	-	16	35	-	44	-	53	ns
		V _{CC} = 5.0 V; C _L = 15 pF	-	13	-	-	-	-	-	ns
t _t	transition time	nQn; see Figure 7 [2]								
		V _{CC} = 4.5 V	-	7	15	-	19	-	22	ns
t _W	pulse width	nCP0, nCP1 HIGH or LOW; see Figure 7								
		V _{CC} = 4.5 V	20	10	-	25	-	30	-	ns
		nMR HIGH; see Figure 7								
t _{rec}	recovery time	nMR to nCP0, nCP1; see Figure 7								
		V _{CC} = 4.5 V	0	-8	-	0	-	0	-	ns
t _{su}	set-up time	nCP0 to nCP1; nCP1 to nCP0; see Figure 7								
		V _{CC} = 4.5 V	16	6	-	20	-	24	-	ns
f _{max}	maximum frequency	nCP0, nCP1; see Figure 7								
		V _{CC} = 4.5 V	30	58	-	24	-	20	-	MHz
		V _{CC} = 5.0 V; C _L = 15 pF	-	64	-	-	-	-	-	MHz
C _{PD}	power dissipation capacitance	V _I = GND to V _{CC} - 1.5 V; V _{CC} = 5 V; f _i = 1 MHz [3]	-	24	-	-	-	-	-	pF

[1] t_{pd} is the same as t_{PHL} and t_{PLH}.

[2] t_t is the same as t_{THL} and t_{TLH}.

[3] C_{PD} is used to determine the dynamic power dissipation (P_D in μW):

$$P_D = C_{PD} \times V_{CC}^2 \times f_i \times N + \sum(C_L \times V_{CC}^2 \times f_o) \text{ where:}$$

f_i = input frequency in MHz;

f_o = output frequency in MHz;

C_L = output load capacitance in pF;

V_{CC} = supply voltage in V;

N = number of inputs switching;

∑(C_L × V_{CC}² × f_o) = sum of outputs.

12. Waveforms

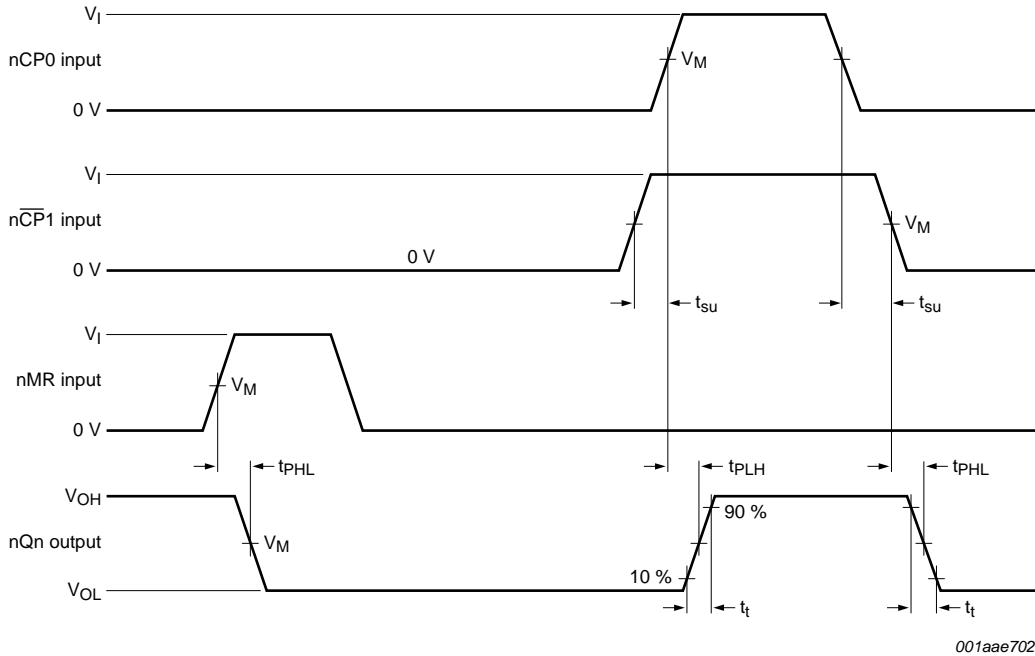

a. nCP0 and nCP1 set-up times, propagation delays and output transition times

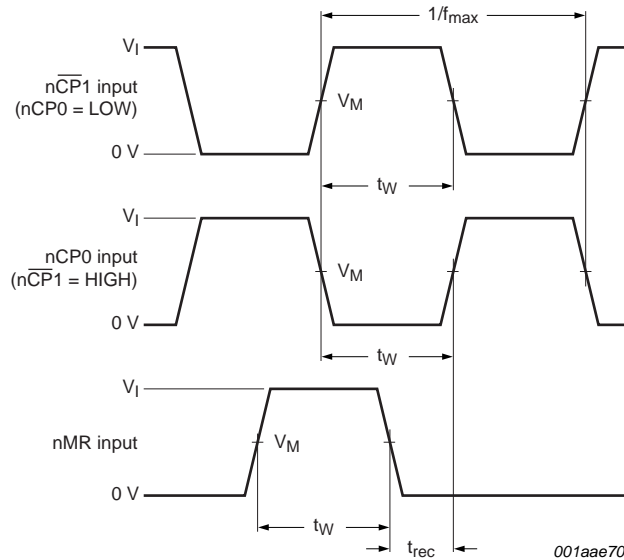

b. nMR recovery time, minimum nCP0, nCP1, nMR pulse widths and maximum frequency

Measurement points are given in [Table 8](#).

The logic levels V_{OH} and V_{OL} are typical output voltage levels that occur with the output load.

Fig 7. Waveforms showing measurements for switching times

Table 8. Measurement points

Type	Input		Output
	V_M	V_I	V_M
74HC4520	$0.5 \times V_{CC}$	GND to V_{CC}	$0.5 \times V_{CC}$
74HCT4520	1.3 V	GND to 3 V	1.3 V

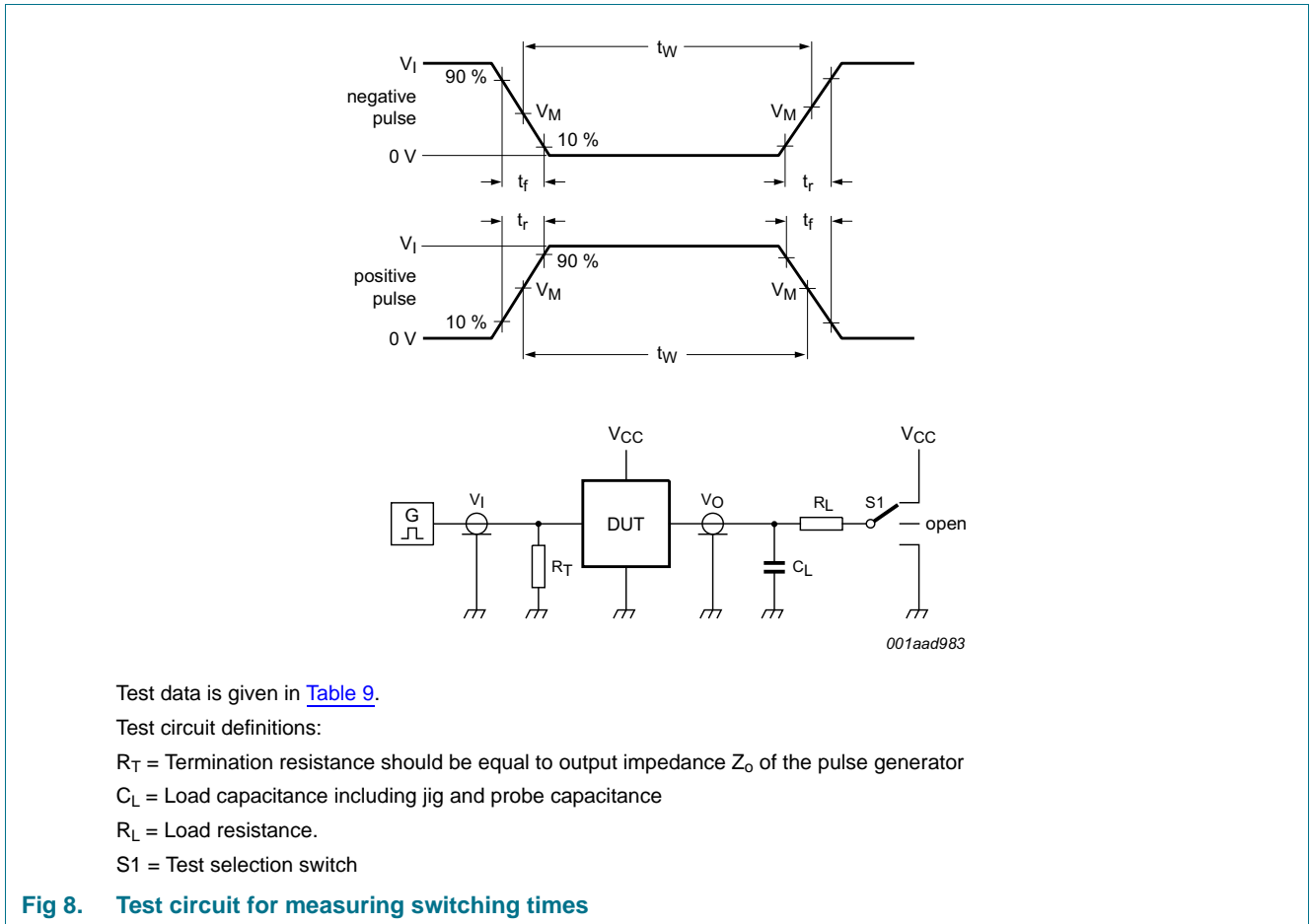

Fig 8. Test circuit for measuring switching times

Table 9. Test data

Type	Input		Load		S1 position
	V_I	t_r, t_f	C_L	R_L	t_{PHL}, t_{PLH}
74HC4520	V_{CC}	6 ns	15 pF, 50 pF	1 k Ω	open
74HCT4520	3 V	6 ns	15 pF, 50 pF	1 k Ω	open

13. Package outline

DIP16: plastic dual in-line package; 16 leads (300 mil)

SOT38-4

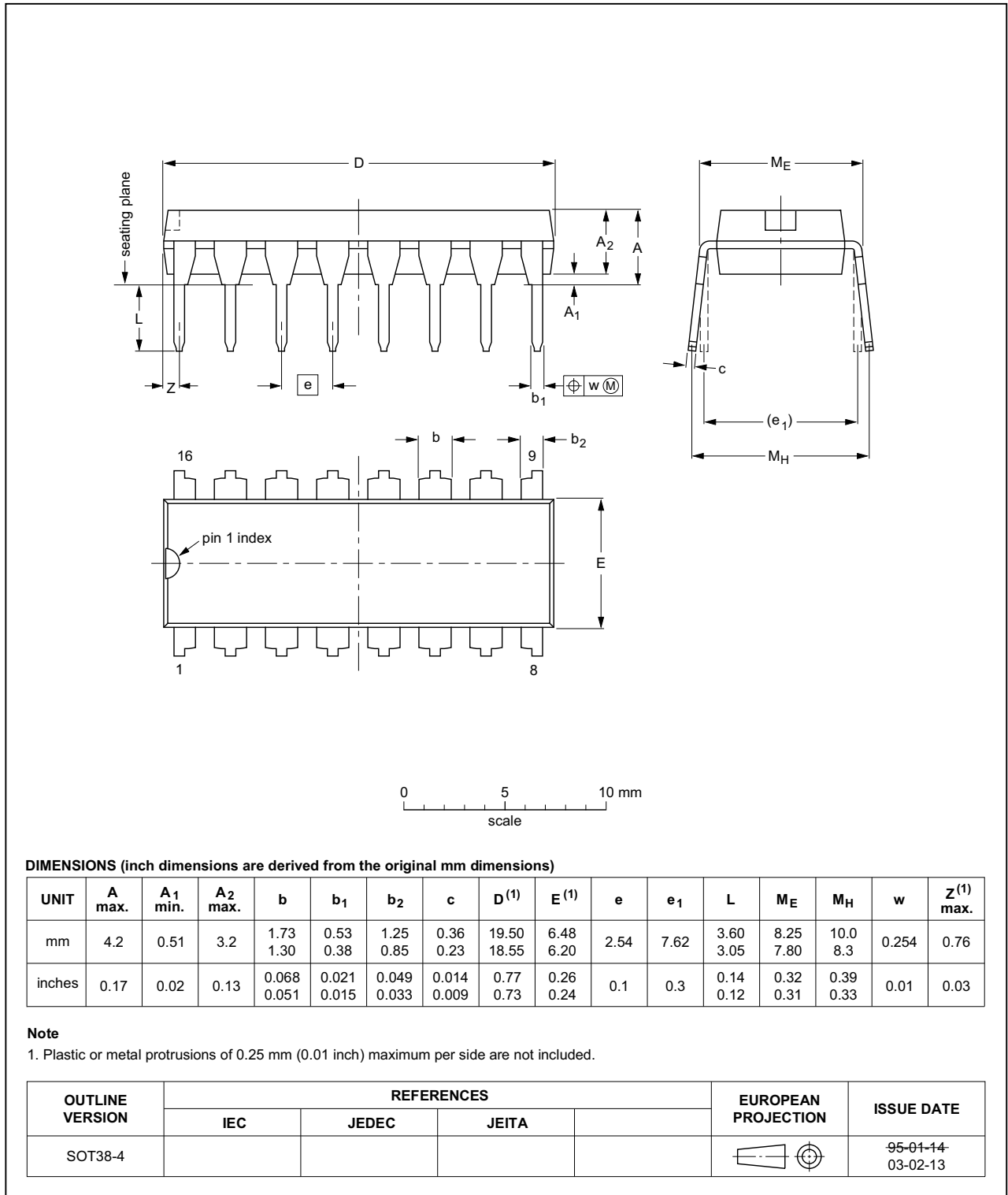

Fig 9. Package outline SOT38-4 (DIP16)

SO16: plastic small outline package; 16 leads; body width 3.9 mm

SOT109-1

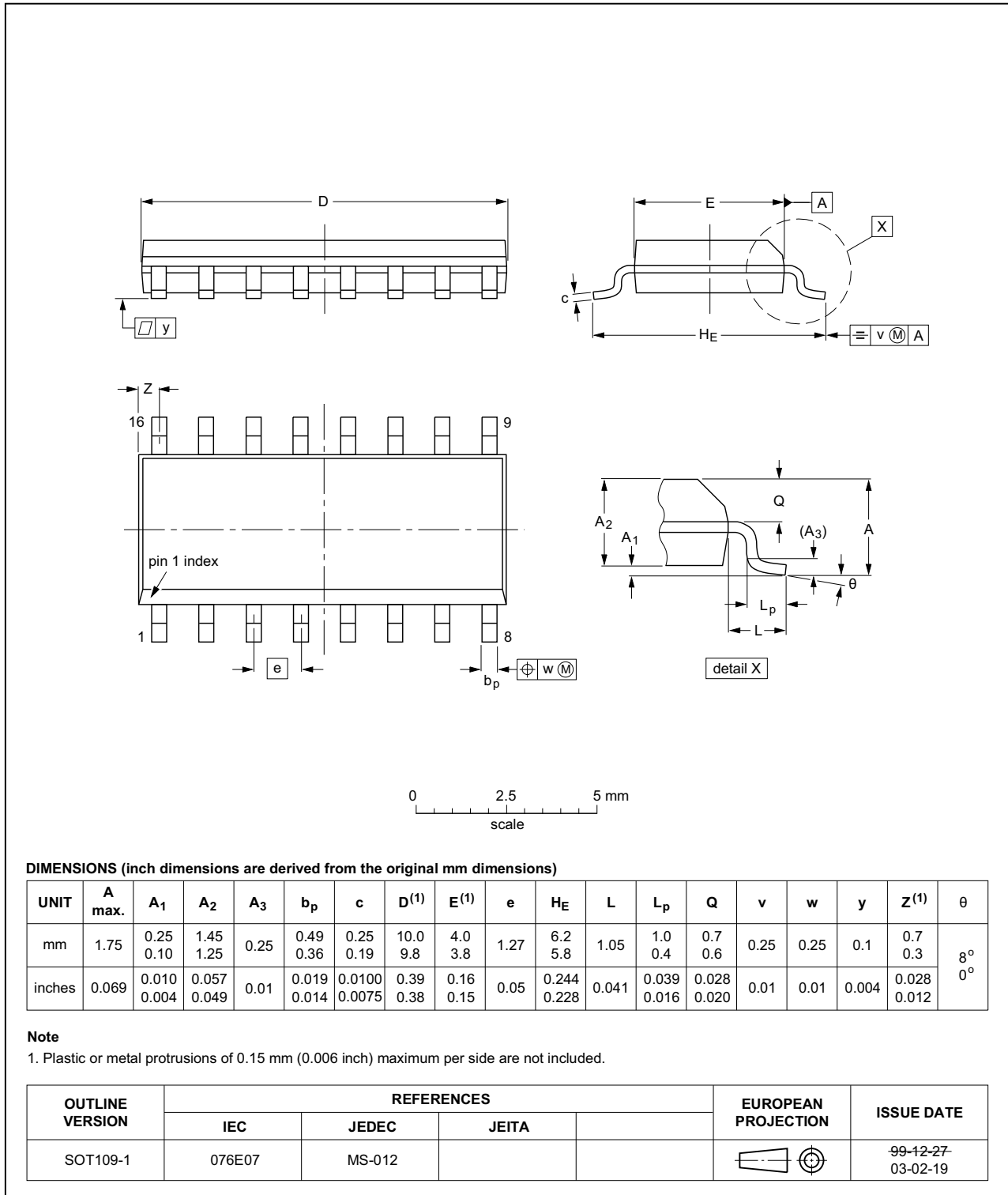

Fig 10. Package outline SOT109-1 (SO16)

SSOP16: plastic shrink small outline package; 16 leads; body width 5.3 mm

SOT338-1

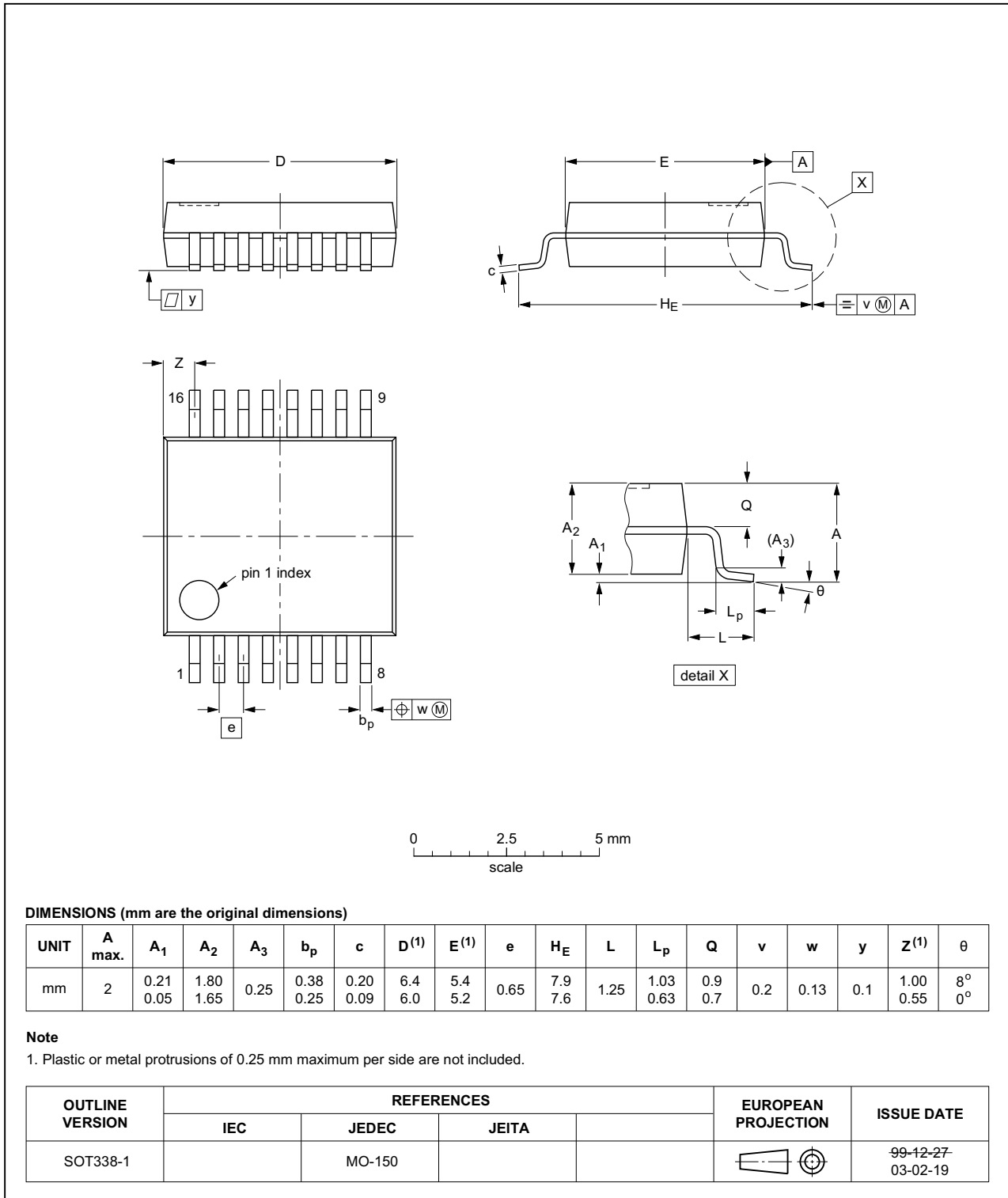

Fig 11. Package outline SOT338-1 (SSOP16)

TSSOP16: plastic thin shrink small outline package; 16 leads; body width 4.4 mm

SOT403-1

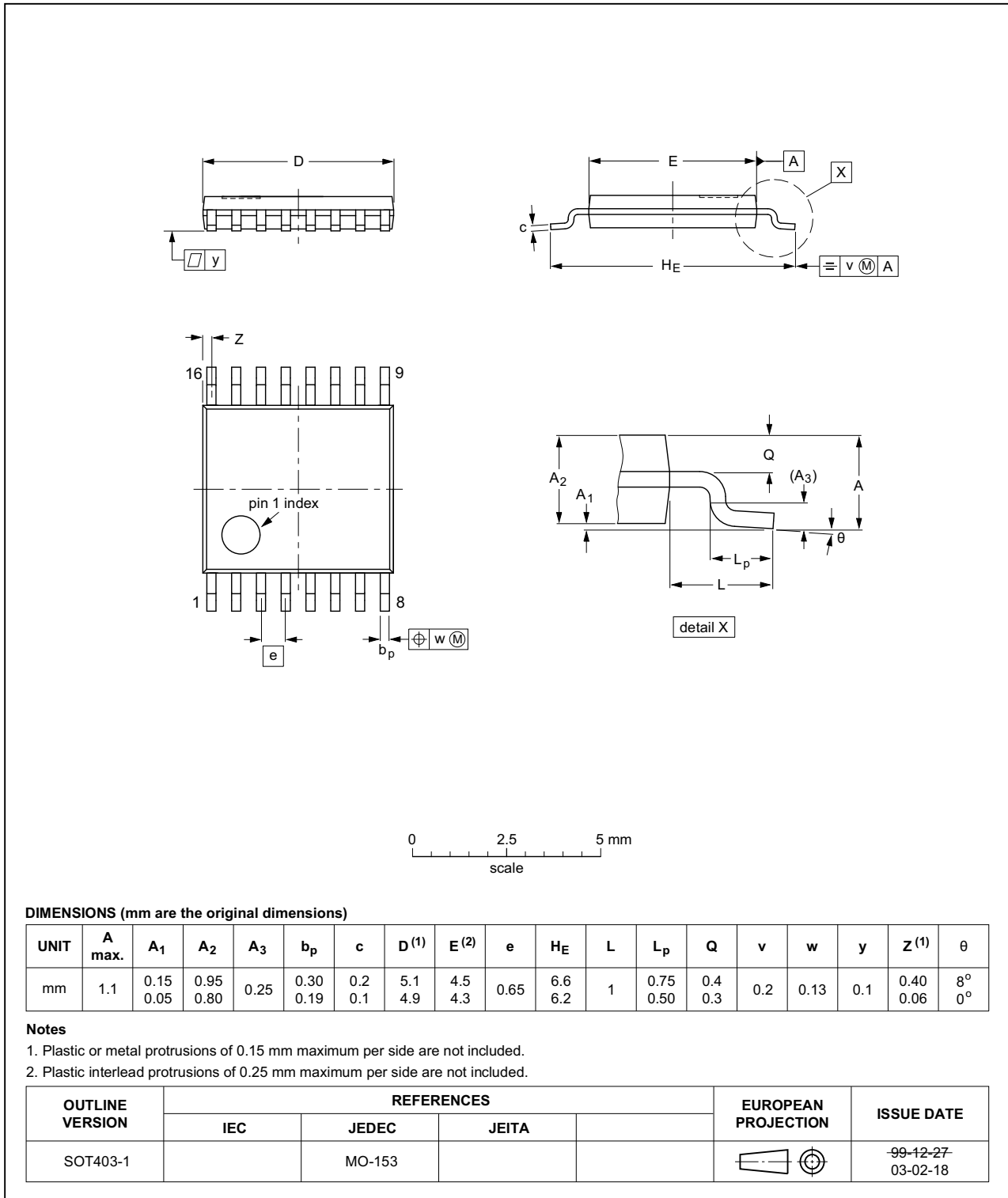

Fig 12. Package outline SOT403-1 (TSSOP16)

14. Abbreviations

Table 10. Abbreviations

Acronym	Description
CMOS	Complementary Metal-Oxide Semiconductor
DUT	Device Under Test
ESD	ElectroStatic Discharge
HBM	Human Body Model
LSTTL	Low-power Schottky Transistor-Transistor Logic
MM	Machine Model
TTL	Transistor-Transistor Logic

15. Revision history

Table 11. Revision history

Document ID	Release date	Data sheet status	Change notice	Supersedes
74HC_HCT4520 v.3	20141204	Product data sheet	-	74HC_HCT4520_CNV v.2
Modifications:	<ul style="list-style-type: none"> The format of this data sheet has been redesigned to comply with the new identity guidelines of NXP Semiconductors. Legal texts have been adapted to the new company name where appropriate. 			
74HC_HCT4520_CNV v.2	19930927	Product specification	-	-

16. Legal information

16.1 Data sheet status

Document status ^{[1][2]}	Product status ^[3]	Definition
Objective [short] data sheet	Development	This document contains data from the objective specification for product development.
Preliminary [short] data sheet	Qualification	This document contains data from the preliminary specification.
Product [short] data sheet	Production	This document contains the product specification.

[1] Please consult the most recently issued document before initiating or completing a design.

[2] The term 'short data sheet' is explained in section "Definitions".

[3] The product status of device(s) described in this document may have changed since this document was published and may differ in case of multiple devices. The latest product status information is available on the Internet at URL <http://www.nxp.com>.

16.2 Definitions

Draft — The document is a draft version only. The content is still under internal review and subject to formal approval, which may result in modifications or additions. NXP Semiconductors does not give any representations or warranties as to the accuracy or completeness of information included herein and shall have no liability for the consequences of use of such information.

Short data sheet — A short data sheet is an extract from a full data sheet with the same product type number(s) and title. A short data sheet is intended for quick reference only and should not be relied upon to contain detailed and full information. For detailed and full information see the relevant full data sheet, which is available on request via the local NXP Semiconductors sales office. In case of any inconsistency or conflict with the short data sheet, the full data sheet shall prevail.

Product specification — The information and data provided in a Product data sheet shall define the specification of the product as agreed between NXP Semiconductors and its customer, unless NXP Semiconductors and customer have explicitly agreed otherwise in writing. In no event however, shall an agreement be valid in which the NXP Semiconductors product is deemed to offer functions and qualities beyond those described in the Product data sheet.

16.3 Disclaimers

Limited warranty and liability — Information in this document is believed to be accurate and reliable. However, NXP Semiconductors does not give any representations or warranties, expressed or implied, as to the accuracy or completeness of such information and shall have no liability for the consequences of use of such information. NXP Semiconductors takes no responsibility for the content in this document if provided by an information source outside of NXP Semiconductors.

In no event shall NXP Semiconductors be liable for any indirect, incidental, punitive, special or consequential damages (including - without limitation - lost profits, lost savings, business interruption, costs related to the removal or replacement of any products or rework charges) whether or not such damages are based on tort (including negligence), warranty, breach of contract or any other legal theory.

Notwithstanding any damages that customer might incur for any reason whatsoever, NXP Semiconductors' aggregate and cumulative liability towards customer for the products described herein shall be limited in accordance with the *Terms and conditions of commercial sale* of NXP Semiconductors.

Right to make changes — NXP Semiconductors reserves the right to make changes to information published in this document, including without limitation specifications and product descriptions, at any time and without notice. This document supersedes and replaces all information supplied prior to the publication hereof.

Suitability for use — NXP Semiconductors products are not designed, authorized or warranted to be suitable for use in life support, life-critical or safety-critical systems or equipment, nor in applications where failure or malfunction of an NXP Semiconductors product can reasonably be expected to result in personal injury, death or severe property or environmental damage. NXP Semiconductors and its suppliers accept no liability for inclusion and/or use of NXP Semiconductors products in such equipment or applications and therefore such inclusion and/or use is at the customer's own risk.

Applications — Applications that are described herein for any of these products are for illustrative purposes only. NXP Semiconductors makes no representation or warranty that such applications will be suitable for the specified use without further testing or modification.

Customers are responsible for the design and operation of their applications and products using NXP Semiconductors products, and NXP Semiconductors accepts no liability for any assistance with applications or customer product design. It is customer's sole responsibility to determine whether the NXP Semiconductors product is suitable and fit for the customer's applications and products planned, as well as for the planned application and use of customer's third party customer(s). Customers should provide appropriate design and operating safeguards to minimize the risks associated with their applications and products.

NXP Semiconductors does not accept any liability related to any default, damage, costs or problem which is based on any weakness or default in the customer's applications or products, or the application or use by customer's third party customer(s). Customer is responsible for doing all necessary testing for the customer's applications and products using NXP Semiconductors products in order to avoid a default of the applications and the products or of the application or use by customer's third party customer(s). NXP does not accept any liability in this respect.

Limiting values — Stress above one or more limiting values (as defined in the Absolute Maximum Ratings System of IEC 60134) will cause permanent damage to the device. Limiting values are stress ratings only and (proper) operation of the device at these or any other conditions above those given in the Recommended operating conditions section (if present) or the Characteristics sections of this document is not warranted. Constant or repeated exposure to limiting values will permanently and irreversibly affect the quality and reliability of the device.

Terms and conditions of commercial sale — NXP Semiconductors products are sold subject to the general terms and conditions of commercial sale, as published at <http://www.nxp.com/profile/terms>, unless otherwise agreed in a valid written individual agreement. In case an individual agreement is concluded only the terms and conditions of the respective agreement shall apply. NXP Semiconductors hereby expressly objects to applying the customer's general terms and conditions with regard to the purchase of NXP Semiconductors products by customer.

No offer to sell or license — Nothing in this document may be interpreted or construed as an offer to sell products that is open for acceptance or the grant, conveyance or implication of any license under any copyrights, patents or other industrial or intellectual property rights.

Export control — This document as well as the item(s) described herein may be subject to export control regulations. Export might require a prior authorization from competent authorities.

Non-automotive qualified products — Unless this data sheet expressly states that this specific NXP Semiconductors product is automotive qualified, the product is not suitable for automotive use. It is neither qualified nor tested in accordance with automotive testing or application requirements. NXP Semiconductors accepts no liability for inclusion and/or use of non-automotive qualified products in automotive equipment or applications.

In the event that customer uses the product for design-in and use in automotive applications to automotive specifications and standards, customer (a) shall use the product without NXP Semiconductors' warranty of the product for such automotive applications, use and specifications, and (b) whenever customer uses the product for automotive applications beyond

NXP Semiconductors' specifications such use shall be solely at customer's own risk, and (c) customer fully indemnifies NXP Semiconductors for any liability, damages or failed product claims resulting from customer design and use of the product for automotive applications beyond NXP Semiconductors' standard warranty and NXP Semiconductors' product specifications.

Translations — A non-English (translated) version of a document is for reference only. The English version shall prevail in case of any discrepancy between the translated and English versions.

16.4 Trademarks

Notice: All referenced brands, product names, service names and trademarks are the property of their respective owners.

17. Contact information

For more information, please visit: <http://www.nxp.com>

For sales office addresses, please send an email to: salesaddresses@nxp.com

18. Contents

1	General description	1
2	Features and benefits	1
3	Applications	1
4	Ordering information	2
5	Functional diagram	2
6	Pinning information	4
6.1	Pinning	4
6.2	Pin description	4
7	Functional description	5
8	Limiting values	5
9	Recommended operating conditions	6
10	Static characteristics	6
11	Dynamic characteristics	7
12	Waveforms	10
13	Package outline	12
14	Abbreviations	16
15	Revision history	16
16	Legal information	17
16.1	Data sheet status	17
16.2	Definitions	17
16.3	Disclaimers	17
16.4	Trademarks	18
17	Contact information	18
18	Contents	19

Please be aware that important notices concerning this document and the product(s) described herein, have been included in section 'Legal information'.

© NXP Semiconductors N.V. 2014.

All rights reserved.

For more information, please visit: <http://www.nxp.com>



For sales office addresses, please send an email to: salesaddresses@nxp.com

Date of release: 4 December 2014

Document identifier: 74HC_HCT4520

Looking for pricing, stock, or lifecycle information?

Click below to explore more details on WIN SOURCE:

-  [View 74HC4520N on WIN SOURCE](#)
-  [NXP / Nexperia Information](#)

Optimize Your Supply Chain with WIN SOURCE Solutions

-  Global Sourcing Solution
-  Obsolete Management
-  Cost Control Management
-  Shortage Management
-  Alternative Solution
-  Excess Inventory Management