



**THE DATASHEET OF
SN74LVC1G373DCKR**



SN74LVC1G373 Single D-Type Latch With 3-State Output

1 Features

- Available in the Texas Instruments NanoFree™ Package
- Supports 5-V V_{CC} Operation
- Inputs Accept Voltages to 5.5 V
- Provides Down Translation to V_{CC}
- Max t_{pd} of 4 ns at 3.3 V
- Low Power Consumption: 10- μ A Maximum I_{CC}
- ± 24 -mA Output Drive at 3.3 V
- I_{off} Supports Partial-Power-Down Mode and Back Drive Protection
- Latch-Up Performance Exceeds 100 mA Per JESD 78, Class II

2 Applications

- Servers
- Printers
- Telecom and Grid Infrastructure
- Memory Addressing
- Buffer Registers
- Electronic Point of Sale

3 Description

The SN74LVC1G373 device is a single D-type latch designed for 1.65-V to 5.5-V V_{CC} operation.

This device is particularly suitable for implementing buffer registers, I/O ports, bidirectional bus drivers, and working registers. While the latch-enable (LE) input is high, the Q outputs follow the data (D) inputs. When LE is taken low, the Q outputs are latched at the logic levels set up at the D inputs.

NanoFree™ package technology is a major breakthrough in IC packaging concepts, using the die as the package.

\overline{OE} does not affect the internal operations of the latch. Old data can be retained or new data can be entered while the outputs are in the high-impedance state.

Device Information(1)

PACKAGE NUMBER	PACKAGE	BODY SIZE (NOM)
SN74LVC1G373DBV	SOT-23 (6)	2.90 mm x 1.60 mm
SN74LVC1G373DCK	SC70 (6)	2.00 mm x 1.25 mm
SN74LVC1G373YZP	DSBGA (6)	1.41 mm x 0.91 mm

(1) For all available packages, see the orderable addendum at the end of the data sheet.

Logic Diagram (Positive Logic)

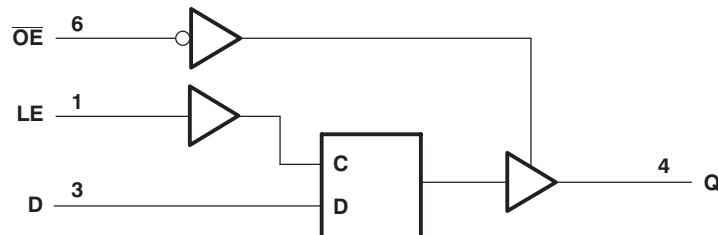

Table of Contents

1 Features	1	8.1 Overview	12
2 Applications	1	8.2 Functional Block Diagram	12
3 Description	1	8.3 Feature Description	12
4 Revision History	2	8.4 Device Functional Modes	13
5 Pin Configuration and Functions	3	9 Application and Implementation	14
6 Specifications	4	9.1 Application Information	14
6.1 Absolute Maximum Ratings	4	9.2 Typical Application	14
6.2 ESD Ratings	4	10 Power Supply Recommendations	16
6.3 Recommended Operating Conditions	5	11 Layout	16
6.4 Thermal Information	5	11.1 Layout Guidelines	16
6.5 Electrical Characteristics	6	11.2 Layout Example	16
6.6 Timing Requirements: $T_A = -40^{\circ}\text{C}$ to $+85^{\circ}\text{C}$	6	12 Device and Documentation Support	17
6.7 Timing Requirements: $T_A = -40^{\circ}\text{C}$ to $+125^{\circ}\text{C}$	6	12.1 Documentation Support	17
6.8 Switching Characteristics: $T_A = -40^{\circ}\text{C}$ to $+85^{\circ}\text{C}$	7	12.2 Receiving Notification of Documentation Updates	17
6.9 Switching Characteristics: $T_A = -40^{\circ}\text{C}$ to $+85^{\circ}\text{C}$	7	12.3 Community Resource	17
6.10 Switching Characteristics: $T_A = -40^{\circ}\text{C}$ to $+125^{\circ}\text{C}$	8	12.4 Trademarks	17
6.11 Operating Characteristics	8	12.5 Electrostatic Discharge Caution	17
6.12 Typical Characteristics	9	12.6 Glossary	17
7 Parameter Measurement Information	10	13 Mechanical, Packaging, and Orderable Information	17
8 Detailed Description	12		

4 Revision History

NOTE: Page numbers for previous revisions may differ from page numbers in the current version.

Changes from Revision E (September 2016) to Revision F	Page
• Changed YZP Package pinout diagram and added YZP pin numbers in <i>Pin Functions</i> table	3
• Added <i>Balanced High-Drive CMOS Push-Pull Outputs, Standard CMOS Inputs, Clamp Diodes, Partial Power Down (I_{off}), Over-voltage Tolerant Inputs</i>	12
• Added <i>Trace Example</i> in <i>Layout Example</i> section	16
• Added <i>Documentation Support</i> section	17

Changes from Revision D (December 2013) to Revision E	Page
• Added <i>Applications</i> section, <i>Device Information</i> table, <i>ESD Ratings</i> table, <i>Feature Description</i> section, <i>Device Functional Modes</i> , <i>Application and Implementation</i> section, <i>Power Supply Recommendations</i> section, <i>Layout</i> section, <i>Device and Documentation Support</i> section, and <i>Mechanical, Packaging, and Orderable Information</i> section	1

Changes from Revision C (May 2007) to Revision D	Page
• Updated document to new TI data sheet format	1
• Deleted Ordering Information table; see POA at the end of the data sheet	1
• Updated operating temperature range	5

5 Pin Configuration and Functions

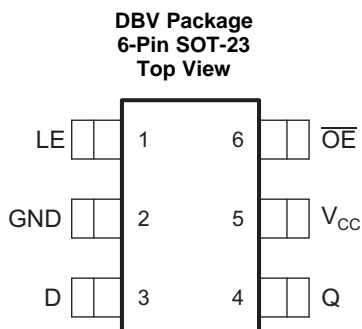

See mechanical drawings for dimensions.

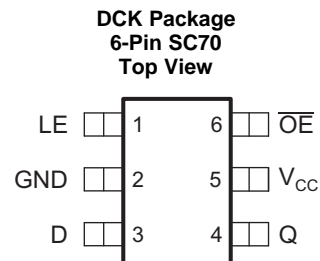

**YZP Package
6-Pin DSBGA
Bottom View**

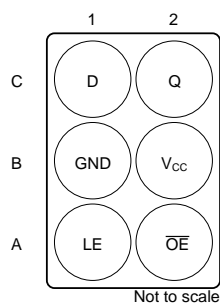

Pin Functions

PIN			I/O	DESCRIPTION
NAME	DCK, DBV	YZP		
LE	1	A1	I	Latch Enable; output follows D input when high
GND	2	B1	—	Ground
D	3	C1	I	D latch input
Q	4	C2	O	Q latch output
V _{CC}	5	B2	—	Positive supply
$\overline{\text{OE}}$	6	A2	I	Active low output enable; Hi-Z output when high

6 Specifications

6.1 Absolute Maximum Ratings

 over operating free-air temperature range (unless otherwise noted)⁽¹⁾

			MIN	MAX	UNIT
V _{CC}	Supply voltage		-0.5	6.5	V
V _I	Input voltage ⁽²⁾		-0.5	6.5	V
V _O	Voltage range applied to any output in the high-impedance or power-off state ⁽²⁾⁽³⁾		-0.5	6.5	V
V _O	Voltage range applied to any output in the high or low state ⁽²⁾⁽³⁾		-0.5	V _{CC} + 0.5	V
I _{IK}	Input clamp current	V _I < 0		-50	mA
I _{OK}	Output clamp current	V _O < 0		-50	mA
I _O	Continuous output current			±50	mA
	Continuous current through V _{CC} or GND			±100	mA
T _J	Absolute maximum Junction temperature			150	°C
T _{stg}	Storage temperature		-65	150	°C

- (1) Stresses beyond those listed under *Absolute Maximum Ratings* may cause permanent damage to the device. These are stress ratings only, which do not imply functional operation of the device at these or any other conditions beyond those indicated under *Recommended Operating Conditions*. Exposure to absolute-maximum-rated conditions for extended periods may affect device reliability.
- (2) The input and output negative-voltage ratings may be exceeded if the input and output current ratings are observed.
- (3) The value of V_{CC} is provided in the *Recommended Operating Conditions*.

6.2 ESD Ratings

			VALUE	UNIT
V _(ESD)	Electrostatic discharge	Human-body model (HBM), per ANSI/ESDA/JEDEC JS-001 ⁽¹⁾	±2000	V
		Charged-device model (CDM), per JEDEC specification JESD22-C101 ⁽²⁾	±1500	

- (1) JEDEC document JEP155 states that 500-V HBM allows safe manufacturing with a standard ESD control process.
- (2) JEDEC document JEP157 states that 250-V CDM allows safe manufacturing with a standard ESD control process. CDM tested on DBV package

6.3 Recommended Operating Conditions

See ⁽¹⁾

		MIN	MAX	UNIT	
V _{CC}	Supply voltage	Operating	1.65	5.5	V
		Data retention only	1.5		
V _{IH}	High-level input voltage	V _{CC} = 1.65 V to 1.95 V	0.65 × V _{CC}	5.5	V
		V _{CC} = 2.3 V to 2.7 V	1.7	5.5	
		V _{CC} = 3 V to 3.6 V	2	5.5	
		V _{CC} = 4.5 V to 5.5 V	0.7 × V _{CC}	5.5	
V _{IL}	Low-level input voltage	V _{CC} = 1.65 V to 1.95 V	0	0.35 × V _{CC}	V
		V _{CC} = 2.3 V to 2.7 V	0	0.7	
		V _{CC} = 3 V to 3.6 V	0	0.8	
		V _{CC} = 4.5 V to 5.5 V	0	0.3 × V _{CC}	
V _O	Output voltage	0	V _{CC}	V	
I _{OH}	High-level output current	V _{CC} = 1.65 V		–4	mA
		V _{CC} = 2.3 V		–8	
		V _{CC} = 3 V		–16	
		V _{CC} = 4.5 V		–24	
I _{OL}	Low-level output current	V _{CC} = 1.65 V		4	mA
		V _{CC} = 2.3 V		8	
		V _{CC} = 3 V		16	
		V _{CC} = 4.5 V		24	
Δt/Δv	Input transition rise or fall rate	V _{CC} = 1.8 V ± 0.15 V, 2.5 V ± 0.2 V		20	ns/V
		V _{CC} = 3.3 V ± 0.3 V		10	
		V _{CC} = 5 V ± 0.5 V		5	
T _A	Operating free-air temperature	DSBGA package	–40	85	°C
		All other packages	–40	125	

(1) All unused inputs of the device must be held at V_{CC} or GND to ensure proper device operation. See [Implications of Slow or Floating CMOS Inputs](#) (SCBA004).

6.4 Thermal Information

THERMAL METRIC ⁽¹⁾		SN74LVC1G373			UNIT
		DBV (SOT-23)	DCK (SC70)	YZP (DSBGA)	
		6 PINS	6 PINS	6 PINS	
R _{θJA}	Junction-to-ambient thermal resistance	219.8	255.2	131	°C/W
R _{θJC(top)}	Junction-to-case (top) thermal resistance	189	121.9	1.3	°C/W
R _{θJB}	Junction-to-board thermal resistance	65.8	58	22.6	°C/W
ψ _{JT}	Junction-to-top characterization parameter	67.3	7.2	5.2	°C/W
ψ _{JB}	Junction-to-board characterization parameter	65.2	57.3	22.6	°C/W

(1) For more information about traditional and new thermal metrics, see the [Semiconductor and IC Package Thermal Metrics](#) application report.

6.5 Electrical Characteristics

over recommended operating free-air temperature range (unless otherwise noted)

PARAMETER	TEST CONDITIONS	V _{CC}	MIN	TYP ⁽¹⁾	MAX	UNIT	
V _{OH}	I _{OH} = -100 μA	1.65 V to 5.5 V	V _{CC} - 0.1			V	
	I _{OH} = -4 mA	1.65 V	1.2				
	I _{OH} = -8 mA	2.3 V	1.9				
	I _{OH} = -16 mA	3 V	2.4				
	I _{OH} = -24 mA		2.3				
	I _{OH} = -32 mA	4.5 V	3.8				
V _{OL}	I _{OL} = 100 μA	1.65 V to 5.5 V			0.1	V	
	I _{OL} = 4 mA	1.65 V			0.45		
	I _{OL} = 8 mA	2.3 V			0.3		
	I _{OL} = 16 mA	3 V			0.4		
	I _{OL} = 24 mA		T _A = -40°C to 85°C				0.55
			T _A = -40°C to 125°C				0.65
	I _{OL} = 32 mA	T _A = -40°C to 85°C	4.5 V				0.55
		T _A = -40°C to 125°C					0.65
I _I	V _I = 5.5 V or GND	0 V to 5.5 V			±1	μA	
I _{OZ}	V _O = 0 to 5.5 V	3.6 V			±5		
I _{off}	V _I or V _O = 5.5 V	0			±10		
I _{CC}	V _I = 5.5 V or GND, I _O = 0	1.65 V to 5.5 V			10		
ΔI _{CC}	One input at V _{CC} - 0.6 V, Other inputs at V _{CC} or GND	3 V to 5.5 V			500		
C _i	V _I = V _{CC} or GND	T _A = -40°C to 85°C	3.3 V		3.5	pF	
C _o	V _O = V _{CC} or GND	T _A = -40°C to 85°C	3.3 V		6		

 (1) All typical values are at V_{CC} = 3.3 V, T_A = 25°C.

6.6 Timing Requirements: T_A = -40°C to +85°C

 over recommended operating free-air temperature range (unless otherwise noted) (see [Figure 2](#))

		MIN	MAX	UNIT
t _w	Pulse duration, LE high	3		ns
t _{su}	Setup time, data before LE↓	V _{CC} = 1.8 V ± 0.15 V	2.4	
		V _{CC} = 2.5 V ± 0.2 V	2	
		V _{CC} = 3.3 V ± 0.3 V	1.5	
		V _{CC} = 5 V ± 0.5 V	1.5	
t _h	Hold time, data after LE↓	V _{CC} = 1.8 V ± 0.15 V	2.5	
		V _{CC} = 2.5 V ± 0.2 V	1.5	
		V _{CC} = 3.3 V ± 0.3 V	1.5	
		V _{CC} = 5 V ± 0.5 V	1.5	

6.7 Timing Requirements: T_A = -40°C to +125°C

 over recommended operating free-air temperature range (unless otherwise noted) (see [Figure 2](#))

		MIN	MAX	UNIT
t _w	Pulse duration, LE high	3		ns
t _{su}	Setup time, data before LE↓	V _{CC} = 1.8 V ± 0.15 V	2.9	
		V _{CC} = 2.5 V ± 0.2 V	2.1	
		V _{CC} = 3.3 V ± 0.3 V	1.5	
		V _{CC} = 5 V ± 0.5 V	1.5	
t _h	Hold time, data after LE↓	V _{CC} = 1.8 V ± 0.15 V	3	
		V _{CC} = 2.5 V ± 0.2 V	1.5	
		V _{CC} = 3.3 V ± 0.3 V	1.5	
		V _{CC} = 5 V ± 0.5 V	1.5	

6.8 Switching Characteristics: $T_A = -40^{\circ}\text{C}$ to $+85^{\circ}\text{C}$

 over recommended operating free-air temperature range, $C_L = 15\text{ pF}$ (unless otherwise noted) (see [Figure 2](#))

PARAMETER	FROM (INPUT)	TO (OUTPUT)	TEST CONDITIONS	MIN	MAX	UNIT
t_{pd}	D	Q	$V_{CC} = 1.8\text{ V} \pm 0.15\text{ V}$	2	15	ns
			$V_{CC} = 2.5\text{ V} \pm 0.2\text{ V}$	15	5	
			$V_{CC} = 3.3\text{ V} \pm 0.3\text{ V}$	1	4	
			$V_{CC} = 5\text{ V} \pm 0.5\text{ V}$	1	3.5	
	LE		$V_{CC} = 1.8\text{ V} \pm 0.15\text{ V}$	2	15	
			$V_{CC} = 2.5\text{ V} \pm 0.2\text{ V}$	1.5	5	
			$V_{CC} = 3.3\text{ V} \pm 0.3\text{ V}$	1	4	
			$V_{CC} = 5\text{ V} \pm 0.5\text{ V}$	1	3.5	
t_{en}	\overline{OE}	Q	$V_{CC} = 1.8\text{ V} \pm 0.15\text{ V}$	2	12.5	
			$V_{CC} = 2.5\text{ V} \pm 0.2\text{ V}$	1.5	4.5	
			$V_{CC} = 3.3\text{ V} \pm 0.3\text{ V}$	1	4	
			$V_{CC} = 5\text{ V} \pm 0.5\text{ V}$	1	2.5	
t_{dis}	\overline{OE}	Q	$V_{CC} = 1.8\text{ V} \pm 0.15\text{ V}$	2	14	
			$V_{CC} = 2.5\text{ V} \pm 0.2\text{ V}$	1.5	7	
			$V_{CC} = 3.3\text{ V} \pm 0.3\text{ V}$	1	7.9	
			$V_{CC} = 5\text{ V} \pm 0.5\text{ V}$	1	5.3	

6.9 Switching Characteristics: $T_A = -40^{\circ}\text{C}$ to $+85^{\circ}\text{C}$

 over recommended operating free-air temperature range, $C_L = 30\text{ pF}$ or 50 pF (unless otherwise noted) (see [Figure 3](#))

PARAMETER	FROM (INPUT)	TO (OUTPUT)	TEST CONDITIONS	MIN	MAX	UNIT
t_{pd}	D	Q	$V_{CC} = 1.8\text{ V} \pm 0.15\text{ V}$	2	16	ns
			$V_{CC} = 2.5\text{ V} \pm 0.2\text{ V}$	1.5	7.3	
			$V_{CC} = 3.3\text{ V} \pm 0.3\text{ V}$	1	5.4	
			$V_{CC} = 5\text{ V} \pm 0.5\text{ V}$	1	4	
	LE		$V_{CC} = 1.8\text{ V} \pm 0.15\text{ V}$	2	16.3	
			$V_{CC} = 2.5\text{ V} \pm 0.2\text{ V}$	1.5	7.4	
			$V_{CC} = 3.3\text{ V} \pm 0.3\text{ V}$	1	5.5	
			$V_{CC} = 5\text{ V} \pm 0.5\text{ V}$	1	4	
t_{en}	\overline{OE}	Q	$V_{CC} = 1.8\text{ V} \pm 0.15\text{ V}$	2	13	
			$V_{CC} = 2.5\text{ V} \pm 0.2\text{ V}$	1.5	6.3	
			$V_{CC} = 3.3\text{ V} \pm 0.3\text{ V}$	1	5.1	
			$V_{CC} = 5\text{ V} \pm 0.5\text{ V}$	1	3.7	
t_{dis}	\overline{OE}	Q	$V_{CC} = 1.8\text{ V} \pm 0.15\text{ V}$	2	17.4	
			$V_{CC} = 2.5\text{ V} \pm 0.2\text{ V}$	1	5.9	
			$V_{CC} = 3.3\text{ V} \pm 0.3\text{ V}$	1	6.5	
			$V_{CC} = 5\text{ V} \pm 0.5\text{ V}$	1	4.6	

6.10 Switching Characteristics: $T_A = -40^\circ\text{C}$ to $+125^\circ\text{C}$

 over recommended operating free-air temperature range, $C_L = 30\text{ pF}$ or 50 pF (unless otherwise noted) (see [Figure 3](#))

PARAMETER	FROM (INPUT)	TO (OUTPUT)	TEST CONDITIONS	MIN	MAX	UNIT
t_{pd}	D	Q	$V_{CC} = 1.8\text{ V} \pm 0.15\text{ V}$	2	17	ns
			$V_{CC} = 2.5\text{ V} \pm 0.2\text{ V}$	1.5	8	
			$V_{CC} = 3.3\text{ V} \pm 0.3\text{ V}$	1	6	
			$V_{CC} = 5\text{ V} \pm 0.5\text{ V}$	1	4.5	
	LE		$V_{CC} = 1.8\text{ V} \pm 0.15\text{ V}$	2	17	
			$V_{CC} = 2.5\text{ V} \pm 0.2\text{ V}$	1.5	8	
			$V_{CC} = 3.3\text{ V} \pm 0.3\text{ V}$	1	6	
			$V_{CC} = 5\text{ V} \pm 0.5\text{ V}$	1	4.5	
t_{en}	\overline{OE}	Q	$V_{CC} = 1.8\text{ V} \pm 0.15\text{ V}$	2	13.5	
			$V_{CC} = 2.5\text{ V} \pm 0.2\text{ V}$	1.5	7	
			$V_{CC} = 3.3\text{ V} \pm 0.3\text{ V}$	1	5.5	
			$V_{CC} = 5\text{ V} \pm 0.5\text{ V}$	1	4	
t_{dis}	\overline{OE}	Q	$V_{CC} = 1.8\text{ V} \pm 0.15\text{ V}$	2	18.4	
			$V_{CC} = 2.5\text{ V} \pm 0.2\text{ V}$	1	6.2	
			$V_{CC} = 3.3\text{ V} \pm 0.3\text{ V}$	1	6.8	
			$V_{CC} = 5\text{ V} \pm 0.5\text{ V}$	1	5	
t_{en}	\overline{OE}	Q	$V_{CC} = 1.8\text{ V} \pm 0.15\text{ V}$	2	14	
			$V_{CC} = 2.5\text{ V} \pm 0.2\text{ V}$	1.5	8.3	
			$V_{CC} = 3.3\text{ V} \pm 0.3\text{ V}$	0.9	6.5	
			$V_{CC} = 5\text{ V} \pm 0.5\text{ V}$	0.7	5.5	
t_{dis}	\overline{OE}	Q	$V_{CC} = 1.8\text{ V} \pm 0.15\text{ V}$	2	16	
			$V_{CC} = 2.5\text{ V} \pm 0.2\text{ V}$	1.1	7.3	
			$V_{CC} = 3.3\text{ V} \pm 0.3\text{ V}$	1.4	6	
			$V_{CC} = 5\text{ V} \pm 0.5\text{ V}$	0.8	5.1	

6.11 Operating Characteristics

 $T_A = 25^\circ\text{C}$

PARAMETER		TEST CONDITIONS	TYP	UNIT	
C_{pd}	Power dissipation capacitance	$f = 10\text{ MHz}$	$V_{CC} = 1.8\text{ V}$	19	pF
			$V_{CC} = 2.5\text{ V}$	19	
			$V_{CC} = 3.3\text{ V}$	19	
			$V_{CC} = 5\text{ V}$	20	
	Outputs disabled		$V_{CC} = 1.8\text{ V}$	3	
			$V_{CC} = 2.5\text{ V}$	3	
			$V_{CC} = 3.3\text{ V}$	3	
			$V_{CC} = 5\text{ V}$	4	

6.12 Typical Characteristics

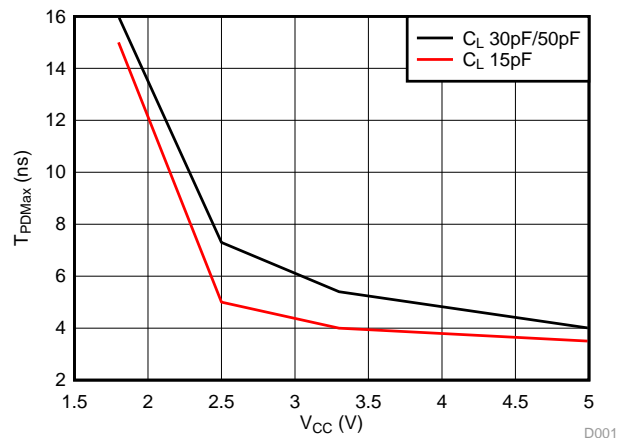
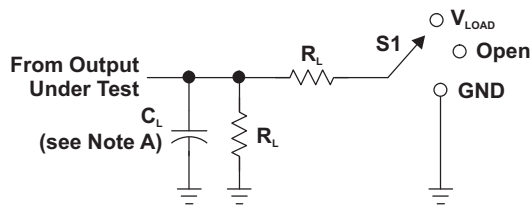

Figure 1. Propagation delay vs V_{CC}

7 Parameter Measurement Information

LOAD CIRCUIT

TEST	S1
t_{PLH}/t_{PHL}	Open
t_{PLZ}/t_{PZL}	V_{LOAD}
t_{PHZ}/t_{PZH}	GND

V_{CC}	INPUTS		V_M	V_{LOAD}	C_L	R_L	V_Δ
	V_i	t_i/t_r					
$1.8\text{ V} \pm 0.15\text{ V}$	V_{CC}	$\leq 2\text{ ns}$	$V_{CC}/2$	$2 \times V_{CC}$	15 pF	1 M Ω	0.15 V
$2.5\text{ V} \pm 0.2\text{ V}$	V_{CC}	$\leq 2\text{ ns}$	$V_{CC}/2$	$2 \times V_{CC}$	15 pF	1 M Ω	0.15 V
$3.3\text{ V} \pm 0.3\text{ V}$	3 V	$\leq 2.5\text{ ns}$	1.5 V	6 V	15 pF	1 M Ω	0.3 V
$5\text{ V} \pm 0.5\text{ V}$	V_{CC}	$\leq 2.5\text{ ns}$	$V_{CC}/2$	$2 \times V_{CC}$	15 pF	1 M Ω	0.3 V

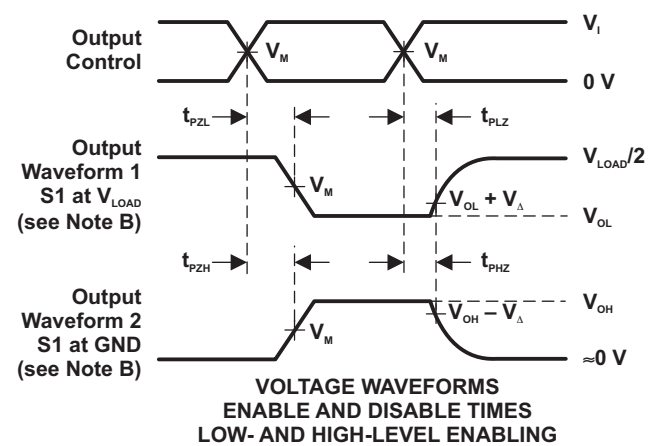
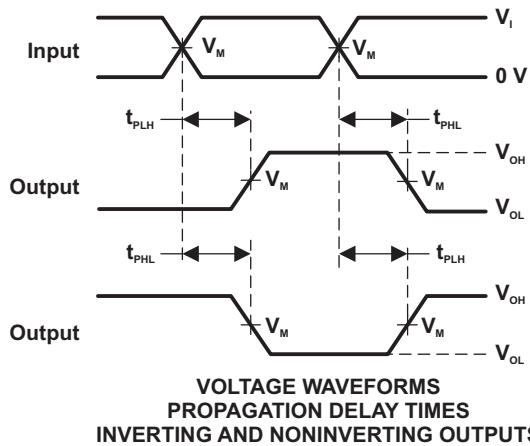
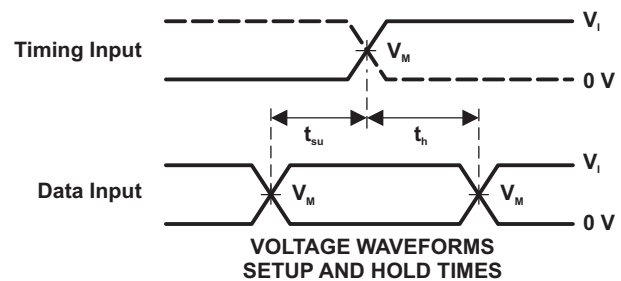
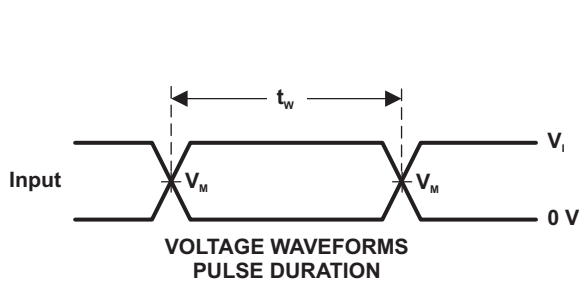

- NOTES: A. C_L includes probe and jig capacitance.
 B. Waveform 1 is for an output with internal conditions such that the output is low, except when disabled by the output control. Waveform 2 is for an output with internal conditions such that the output is high, except when disabled by the output control.
 C. All input pulses are supplied by generators having the following characteristics: PRR \leq 10 MHz, $Z_o = 50\ \Omega$.
 D. The outputs are measured one at a time, with one transition per measurement.
 E. t_{PLZ} and t_{PHZ} are the same as t_{dis} .
 F. t_{PZL} and t_{PZH} are the same as t_{en} .
 G. t_{PLH} and t_{PHL} are the same as t_{pd} .
 H. All parameters and waveforms are not applicable to all devices.

Figure 2. Load Circuit and Voltage Waveforms

Parameter Measurement Information (continued)

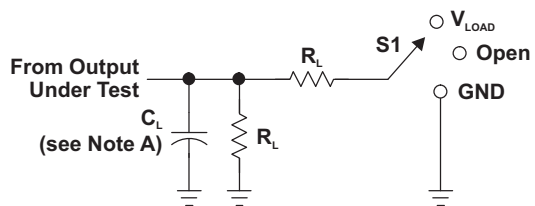

LOAD CIRCUIT

TEST	S1
t_{PLH}/t_{PHL}	Open
t_{PLZ}/t_{PZL}	V_{LOAD}
t_{PHZ}/t_{PZH}	GND

V_{CC}	INPUTS		V_M	V_{LOAD}	C_L	R_L	V_{Δ}
	V_I	t_r/t_f					
$1.8\text{ V} \pm 0.15\text{ V}$	V_{CC}	$\leq 2\text{ ns}$	$V_{CC}/2$	$2 \times V_{CC}$	30 pF	1 k Ω	0.15 V
$2.5\text{ V} \pm 0.2\text{ V}$	V_{CC}	$\leq 2\text{ ns}$	$V_{CC}/2$	$2 \times V_{CC}$	30 pF	500 Ω	0.15 V
$3.3\text{ V} \pm 0.3\text{ V}$	3 V	$\leq 2.5\text{ ns}$	1.5 V	6 V	50 pF	500 Ω	0.3 V
$5\text{ V} \pm 0.5\text{ V}$	V_{CC}	$\leq 2.5\text{ ns}$	$V_{CC}/2$	$2 \times V_{CC}$	50 pF	500 Ω	0.3 V

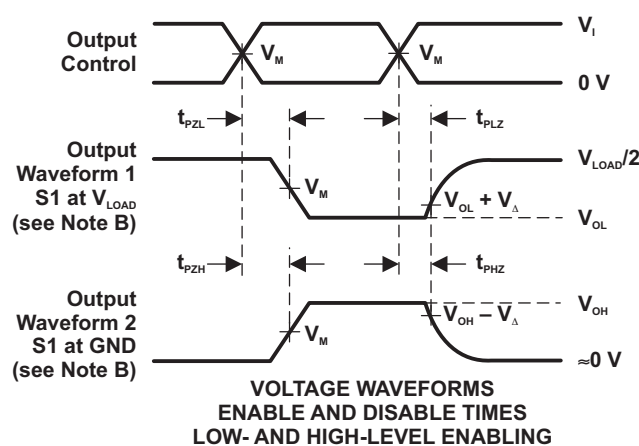
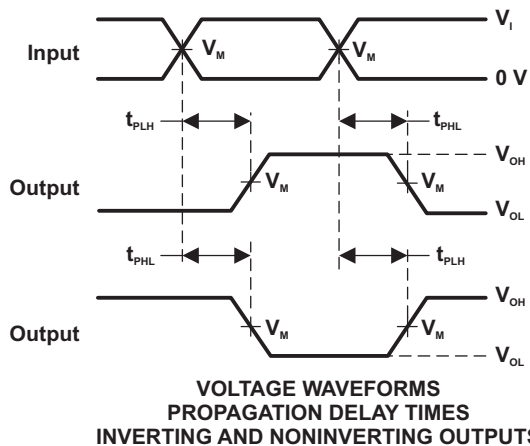
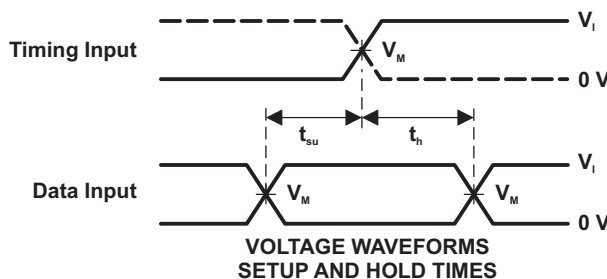
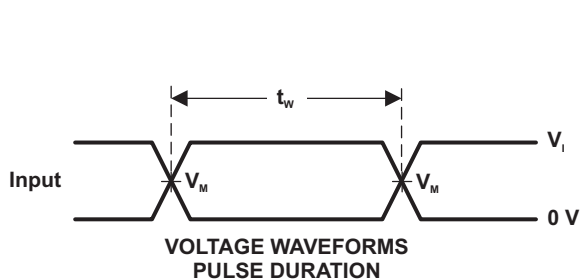

- NOTES: A. C_L includes probe and jig capacitance.
 B. Waveform 1 is for an output with internal conditions such that the output is low, except when disabled by the output control. Waveform 2 is for an output with internal conditions such that the output is high, except when disabled by the output control.
 C. All input pulses are supplied by generators having the following characteristics: PRR \leq 10 MHz, $Z_o = 50 \Omega$.
 D. The outputs are measured one at a time, with one transition per measurement.
 E. t_{PLZ} and t_{PHZ} are the same as t_{dis} .
 F. t_{PZL} and t_{PZH} are the same as t_{on} .
 G. t_{PLH} and t_{PHL} are the same as t_{pd} .
 H. All parameters and waveforms are not applicable to all devices.

Figure 3. Load Circuit and Voltage Waveforms

8 Detailed Description

8.1 Overview

A buffered output-enable (\overline{OE}) input can be used to place the output in either a normal logic state (high or low logic levels) or the high-impedance state. In the high-impedance state, the output neither loads nor drives the bus lines significantly. The high-impedance state and increased drive provide the capability to drive bus lines without interface or pullup components. To ensure the high-impedance state during power up or power down, \overline{OE} should be tied to V_{CC} through a pullup resistor; the minimum value of the resistor is determined by the current-sinking capability of the driver. This device is fully specified for partial-power-down applications using I_{off} . The I_{off} circuitry disables the outputs, preventing damaging current backflow through the device when it is powered down.

8.2 Functional Block Diagram

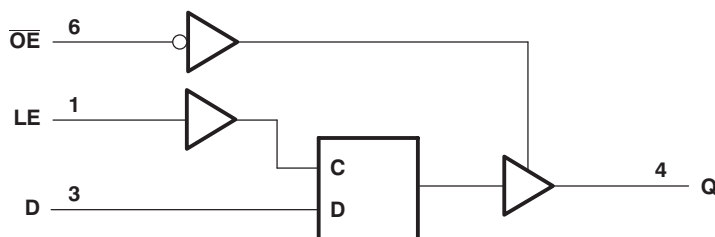

Figure 4. Logic Diagram (Positive Logic)

8.3 Feature Description

8.3.1 Balanced High-Drive CMOS Push-Pull Outputs

A balanced output allows the device to sink and source similar currents. The high drive capability of this device creates fast edges into light loads so routing and load conditions should be considered to prevent ringing. Additionally, the outputs of this device are capable of driving larger currents than the device can sustain without being damaged. It is important for the power output of the device to be limited to avoid thermal runaway and damage due to over-current. The electrical and thermal limits defined in the [Absolute Maximum Ratings](#) must be followed at all times.

8.3.2 Standard CMOS Inputs

Standard CMOS inputs are high impedance and are typically modelled as a resistor in parallel with the input capacitance given in the [Electrical Characteristics](#). The worst case resistance is calculated with the maximum input voltage, given in the [Absolute Maximum Ratings](#), and the maximum input leakage current, given in the [Electrical Characteristics](#), using ohm's law ($R = V \div I$).

Signals applied to the inputs need to have fast edge rates, as defined by $\Delta t/\Delta v$ in [Recommended Operating Conditions](#) to avoid excessive currents and oscillations. If a slow or noisy input signal is required, a device with a Schmitt-trigger input should be utilized to condition the input signal prior to the standard CMOS input.

Feature Description (continued)

8.3.3 Clamp Diodes

The inputs and outputs to this device have negative clamping diodes.

CAUTION

Voltages beyond the values specified in the [Absolute Maximum Ratings](#) table can cause damage to the device. The input negative-voltage and output voltage ratings may be exceeded if the input and output clamp-current ratings are observed.

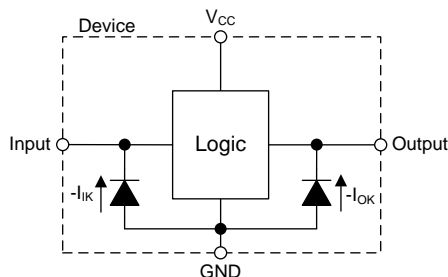

Figure 5. Electrical Placement of Clamping Diodes for Each Input and Output

8.3.4 Partial Power Down (I_{off})

The inputs and outputs for this device enter a high impedance state when the supply voltage is 0 V. The maximum leakage into or out of any input or output pin on the device is specified by I_{off} in the [Electrical Characteristics](#).

8.3.5 Over-voltage Tolerant Inputs

Input signals to this device can be driven above the supply voltage so long as they remain below the maximum input voltage value specified in the [Absolute Maximum Ratings](#).

8.4 Device Functional Modes

Table 1 lists the functions of this device.

Table 1. Function Table

INPUTS			OUTPUT
\overline{OE}	LE	D	Q
L	H	L	L
L	H	H	H
L	L	X	Q_0
H	X	X	Hi-Z

9 Application and Implementation

NOTE

Information in the following applications sections is not part of the TI component specification, and TI does not warrant its accuracy or completeness. TI's customers are responsible for determining suitability of components for their purposes. Customers should validate and test their design implementation to confirm system functionality.

9.1 Application Information

The SN74LVC1G373 latches can be used to store one bit of data. Figure 6 shows a typical application. The multiplexer is used to convert parallel data coming in from the latch into serial data using the A, B, and C select pins moving up in a sequence. With latch input low by a trigger event, the output Q holds the previous Q_0 data entered until the LE pin is cleared.

9.2 Typical Application

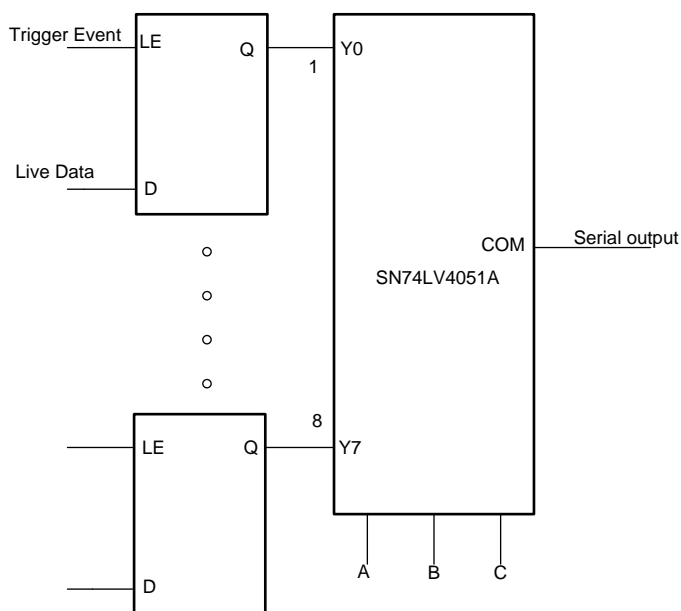

Copyright © 2016, Texas Instruments Incorporated

Figure 6. Latch Used With Multiplexer for Parallel to Serial Conversion

9.2.1 Design Requirements

This device uses CMOS technology and has balanced output drive. Take care to avoid bus contention because it can drive currents that would exceed maximum limits. The high drive also creates fast edges into light loads, so routing and load conditions must be considered to prevent ringing.

Typical Application (continued)

9.2.2 Detailed Design Procedure

1. Recommended Input Conditions
 - For rise time and fall time specifications, see $\Delta t/\Delta V$ in *Recommended Operating Conditions*.
 - For specified High and low levels, see V_{IH} and V_{IL} in *Recommended Operating Conditions*.
 - Inputs are overvoltage tolerant allowing them to go as high as 5.5 V at any valid V_{CC} .
2. Recommended Output Conditions
 - Load currents should not exceed 32 mA per output and 100 mA total through the part.
 - Outputs must not be pulled above V_{CC} .

9.2.3 Application Curve

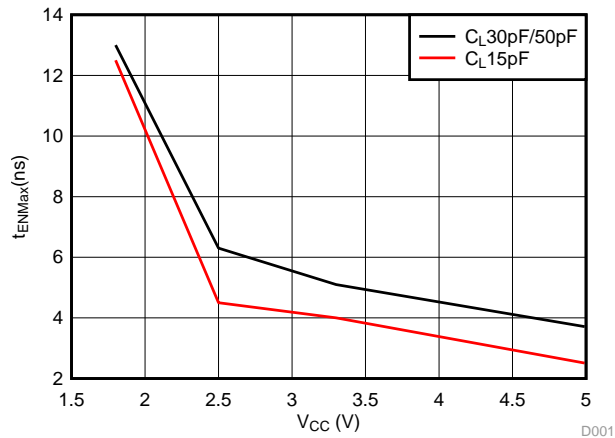

Figure 7. Enable Time vs V_{CC}

10 Power Supply Recommendations

The power supply can be any voltage between the minimum and maximum supply voltage rating located in [Recommended Operating Conditions](#).

Each V_{CC} pin should have a good bypass capacitor to prevent power disturbance. For devices with a single supply, TI recommends a 0.1- μF bypass capacitor. If there are multiple V_{CC} pins, TI recommends 0.01- μF or 0.022- μF bypass capacitor for each power pin. It is acceptable to parallel multiple bypass capacitors to reject different frequencies of noise. 0.1- μF and 1- μF capacitors are commonly used in parallel. The bypass capacitor should be installed as close to the power pin as possible for best results.

11 Layout

11.1 Layout Guidelines

When using multiple bit logic devices, inputs should not float. In many cases, functions or parts of functions of digital logic devices are unused. Some examples are when only two inputs of a triple-input AND gate are used, or when only 3 of the 4-buffer gates are used. Such input pins should not be left unconnected because the undefined voltages at the outside connections result in undefined operational states.

Specified in [Figure 8](#) are rules that must be observed under all circumstances. All unused inputs of digital logic devices must be connected to a high or low bias to prevent them from floating. The logic level that should be applied to any particular unused input depends on the function of the device. Generally they will be tied to GND or VCC, whichever makes more sense or is more convenient.

Even low data rate digital signals can have high frequency signal components due to fast edge rates. When a PCB trace turns a corner at a 90° angle, a reflection can occur. A reflection occurs primarily because of the change of width of the trace. At the apex of the turn, the trace width increases to 1.414 times the width. This increase upsets the transmission-line characteristics, especially the distributed capacitance and self-inductance of the trace which results in the reflection. Not all PCB traces can be straight and therefore some traces must turn corners. [Figure 9](#) shows progressively better techniques of rounding corners. Only the last example (BEST) maintains constant trace width and minimizes reflections.

11.2 Layout Example

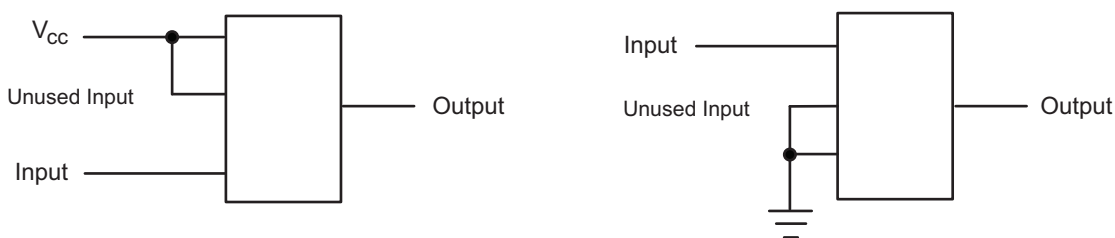

Figure 8. Proper Multiple Input Termination Diagram

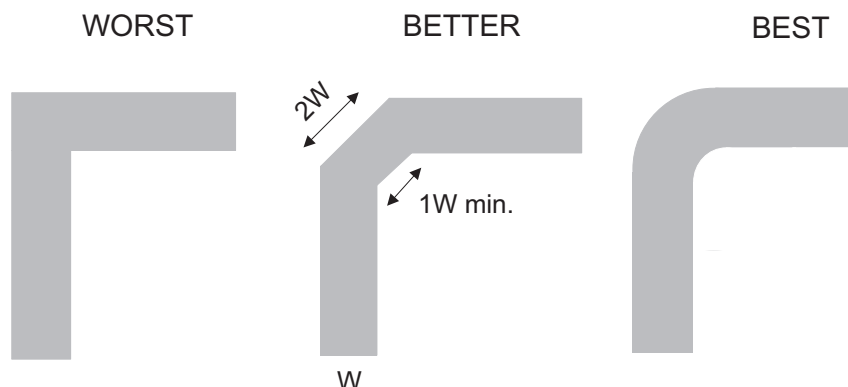

Figure 9. Trace Example

12 Device and Documentation Support

12.1 Documentation Support

12.1.1 Related Documentation

For related documentation see the following:

[Implications of Slow or Floating CMOS Inputs](#) (SCBA004)

12.2 Receiving Notification of Documentation Updates

To receive notification of documentation updates, navigate to the device product folder on ti.com. In the upper right corner, click on *Alert me* to register and receive a weekly digest of any product information that has changed. For change details, review the revision history included in any revised document.

12.3 Community Resource

The following links connect to TI community resources. Linked contents are provided "AS IS" by the respective contributors. They do not constitute TI specifications and do not necessarily reflect TI's views; see TI's [Terms of Use](#).

TI E2E™ Online Community *TI's Engineer-to-Engineer (E2E) Community*. Created to foster collaboration among engineers. At e2e.ti.com, you can ask questions, share knowledge, explore ideas and help solve problems with fellow engineers.

Design Support *TI's Design Support* Quickly find helpful E2E forums along with design support tools and contact information for technical support.

12.4 Trademarks

NanoFree, E2E are trademarks of Texas Instruments.
All other trademarks are the property of their respective owners.

12.5 Electrostatic Discharge Caution



These devices have limited built-in ESD protection. The leads should be shorted together or the device placed in conductive foam during storage or handling to prevent electrostatic damage to the MOS gates.

12.6 Glossary

[SLYZ022](#) — *TI Glossary*.

This glossary lists and explains terms, acronyms, and definitions.

13 Mechanical, Packaging, and Orderable Information

The following pages include mechanical, packaging, and orderable information. This information is the most current data available for the designated devices. This data is subject to change without notice and revision of this document. For browser-based versions of this data sheet, refer to the left-hand navigation.

PACKAGING INFORMATION

Orderable Device	Status (1)	Package Type	Package Drawing	Pins	Package Qty	Eco Plan (2)	Lead finish/ Ball material (6)	MSL Peak Temp (3)	Op Temp (°C)	Device Marking (4/5)	Samples
74LVC1G373DBVRE4	ACTIVE	SOT-23	DBV	6	3000	RoHS & Green	NIPDAU	Level-1-260C-UNLIM	-40 to 125	(CA35, CA3R)	Samples
74LVC1G373DCKRE4	ACTIVE	SC70	DCK	6	3000	RoHS & Green	NIPDAU	Level-1-260C-UNLIM	-40 to 125	D35	Samples
74LVC1G373DCKRG4	ACTIVE	SC70	DCK	6	3000	RoHS & Green	NIPDAU	Level-1-260C-UNLIM	-40 to 125	D35	Samples
SN74LVC1G373DBVR	ACTIVE	SOT-23	DBV	6	3000	RoHS & Green	NIPDAU	Level-1-260C-UNLIM	-40 to 125	(CA35, CA3R)	Samples
SN74LVC1G373DCKR	ACTIVE	SC70	DCK	6	3000	RoHS & Green	NIPDAU SN	Level-1-260C-UNLIM	-40 to 125	(D35, D3J, D3R)	Samples
SN74LVC1G373YZPR	ACTIVE	DSBGA	YZP	6	3000	RoHS & Green	SNAGCU	Level-1-260C-UNLIM	-40 to 85	D3N	Samples

(1) The marketing status values are defined as follows:

ACTIVE: Product device recommended for new designs.

LIFEBUY: TI has announced that the device will be discontinued, and a lifetime-buy period is in effect.

NRND: Not recommended for new designs. Device is in production to support existing customers, but TI does not recommend using this part in a new design.

PREVIEW: Device has been announced but is not in production. Samples may or may not be available.

OBSELETE: TI has discontinued the production of the device.

(2) **RoHS:** TI defines "RoHS" to mean semiconductor products that are compliant with the current EU RoHS requirements for all 10 RoHS substances, including the requirement that RoHS substance do not exceed 0.1% by weight in homogeneous materials. Where designed to be soldered at high temperatures, "RoHS" products are suitable for use in specified lead-free processes. TI may reference these types of products as "Pb-Free".

RoHS Exempt: TI defines "RoHS Exempt" to mean products that contain lead but are compliant with EU RoHS pursuant to a specific EU RoHS exemption.

Green: TI defines "Green" to mean the content of Chlorine (Cl) and Bromine (Br) based flame retardants meet JS709B low halogen requirements of <=1000ppm threshold. Antimony trioxide based flame retardants must also meet the <=1000ppm threshold requirement.

(3) MSL, Peak Temp. - The Moisture Sensitivity Level rating according to the JEDEC industry standard classifications, and peak solder temperature.

(4) There may be additional marking, which relates to the logo, the lot trace code information, or the environmental category on the device.

(5) Multiple Device Markings will be inside parentheses. Only one Device Marking contained in parentheses and separated by a "~" will appear on a device. If a line is indented then it is a continuation of the previous line and the two combined represent the entire Device Marking for that device.

(6) Lead finish/Ball material - Orderable Devices may have multiple material finish options. Finish options are separated by a vertical ruled line. Lead finish/Ball material values may wrap to two lines if the finish value exceeds the maximum column width.

Important Information and Disclaimer: The information provided on this page represents TI's knowledge and belief as of the date that it is provided. TI bases its knowledge and belief on information provided by third parties, and makes no representation or warranty as to the accuracy of such information. Efforts are underway to better integrate information from third parties. TI has taken and continues to take reasonable steps to provide representative and accurate information but may not have conducted destructive testing or chemical analysis on incoming materials and chemicals. TI and TI suppliers consider certain information to be proprietary, and thus CAS numbers and other limited information may not be available for release.

In no event shall TI's liability arising out of such information exceed the total purchase price of the TI part(s) at issue in this document sold by TI to Customer on an annual basis.

TAPE AND REEL INFORMATION

QUADRANT ASSIGNMENTS FOR PIN 1 ORIENTATION IN TAPE

*All dimensions are nominal

Device	Package Type	Package Drawing	Pins	SPQ	Reel Diameter (mm)	Reel Width W1 (mm)	A0 (mm)	B0 (mm)	K0 (mm)	P1 (mm)	W (mm)	Pin1 Quadrant
74LVC1G373DCKRG4	SC70	DCK	6	3000	178.0	9.2	2.4	2.4	1.22	4.0	8.0	Q3
SN74LVC1G373DBVR	SOT-23	DBV	6	3000	178.0	9.2	3.3	3.23	1.55	4.0	8.0	Q3
SN74LVC1G373DBVR	SOT-23	DBV	6	3000	180.0	8.4	3.23	3.17	1.37	4.0	8.0	Q3
SN74LVC1G373DCKR	SC70	DCK	6	3000	180.0	8.4	2.3	2.5	1.2	4.0	8.0	Q3

TAPE AND REEL BOX DIMENSIONS

*All dimensions are nominal

Device	Package Type	Package Drawing	Pins	SPQ	Length (mm)	Width (mm)	Height (mm)
74LVC1G373DCKRG4	SC70	DCK	6	3000	180.0	180.0	18.0
SN74LVC1G373DBVR	SOT-23	DBV	6	3000	180.0	180.0	18.0
SN74LVC1G373DBVR	SOT-23	DBV	6	3000	202.0	201.0	28.0
SN74LVC1G373DCKR	SC70	DCK	6	3000	210.0	185.0	35.0

EXAMPLE BOARD LAYOUT

DBV0006A

SOT-23 - 1.45 mm max height

SMALL OUTLINE TRANSISTOR

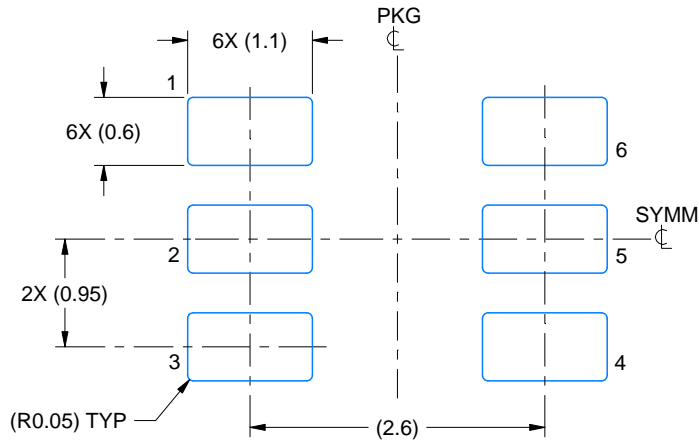

LAND PATTERN EXAMPLE
EXPOSED METAL SHOWN
SCALE:15X

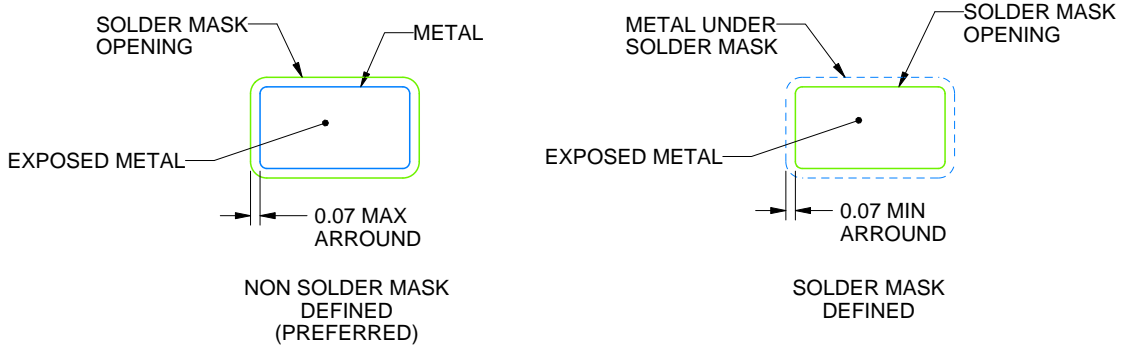

SOLDER MASK DETAILS

4214840/E 02/2024

NOTES: (continued)

- 6. Publication IPC-7351 may have alternate designs.
- 7. Solder mask tolerances between and around signal pads can vary based on board fabrication site.

EXAMPLE STENCIL DESIGN

DBV0006A

SOT-23 - 1.45 mm max height

SMALL OUTLINE TRANSISTOR

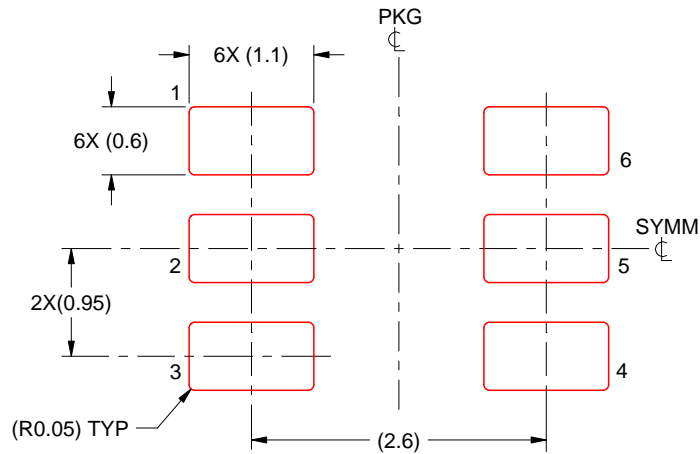

SOLDER PASTE EXAMPLE
BASED ON 0.125 mm THICK STENCIL
SCALE:15X

4214840/E 02/2024

NOTES: (continued)

8. Laser cutting apertures with trapezoidal walls and rounded corners may offer better paste release. IPC-7525 may have alternate design recommendations.
9. Board assembly site may have different recommendations for stencil design.

YZP0006



PACKAGE OUTLINE

DSBGA - 0.5 mm max height

DIE SIZE BALL GRID ARRAY

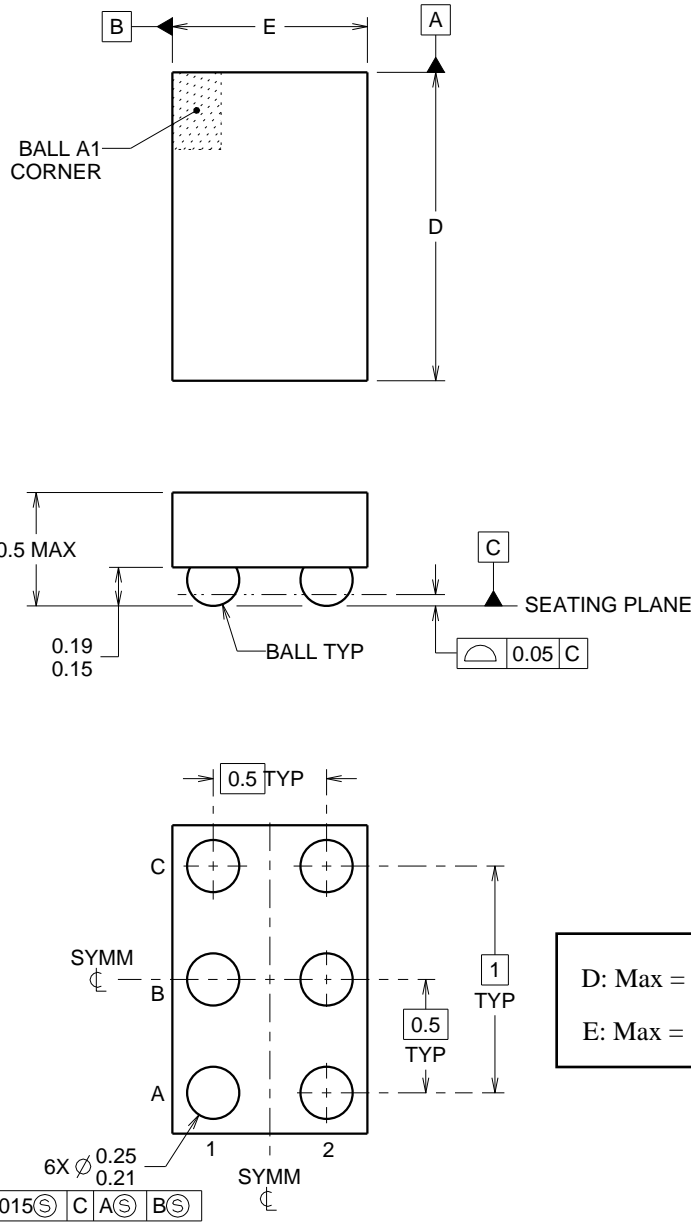

4219524/A 06/2014

NOTES:

NanoFree Is a trademark of Texas Instruments.

1. All linear dimensions are in millimeters. Any dimensions in parenthesis are for reference only. Dimensioning and tolerancing per ASME Y14.5M.
2. This drawing is subject to change without notice.
3. NanoFree™ package configuration.

EXAMPLE BOARD LAYOUT

YZP0006

DSBGA - 0.5 mm max height

DIE SIZE BALL GRID ARRAY



LAND PATTERN EXAMPLE
SCALE:40X

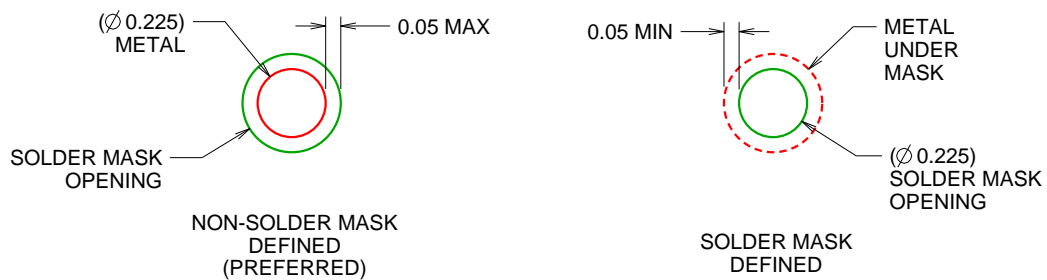

SOLDER MASK DETAILS
NOT TO SCALE

4219524/A 06/2014

NOTES: (continued)

- Final dimensions may vary due to manufacturing tolerance considerations and also routing constraints. For more information, see Texas Instruments literature number SBVA017 (www.ti.com/lit/sbva017).

EXAMPLE STENCIL DESIGN

YZP0006

DSBGA - 0.5 mm max height

DIE SIZE BALL GRID ARRAY

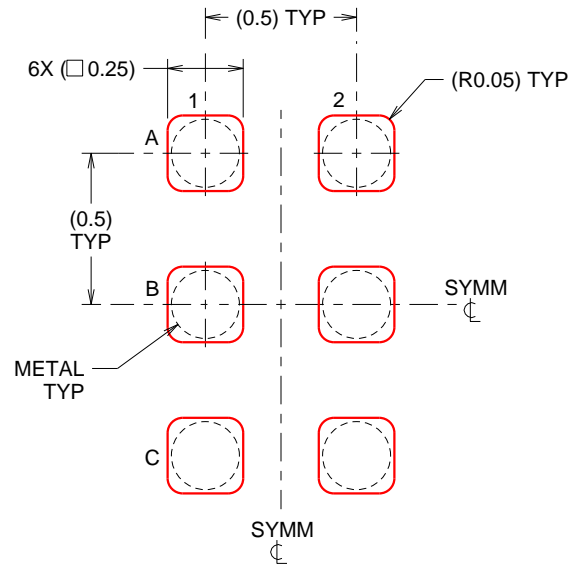

SOLDER PASTE EXAMPLE
BASED ON 0.1 mm THICK STENCIL
SCALE:40X

4219524/A 06/2014

NOTES: (continued)

5. Laser cutting apertures with trapezoidal walls and rounded corners may offer better paste release.

DCK0006A



PACKAGE OUTLINE

SOT - 1.1 max height

SMALL OUTLINE TRANSISTOR

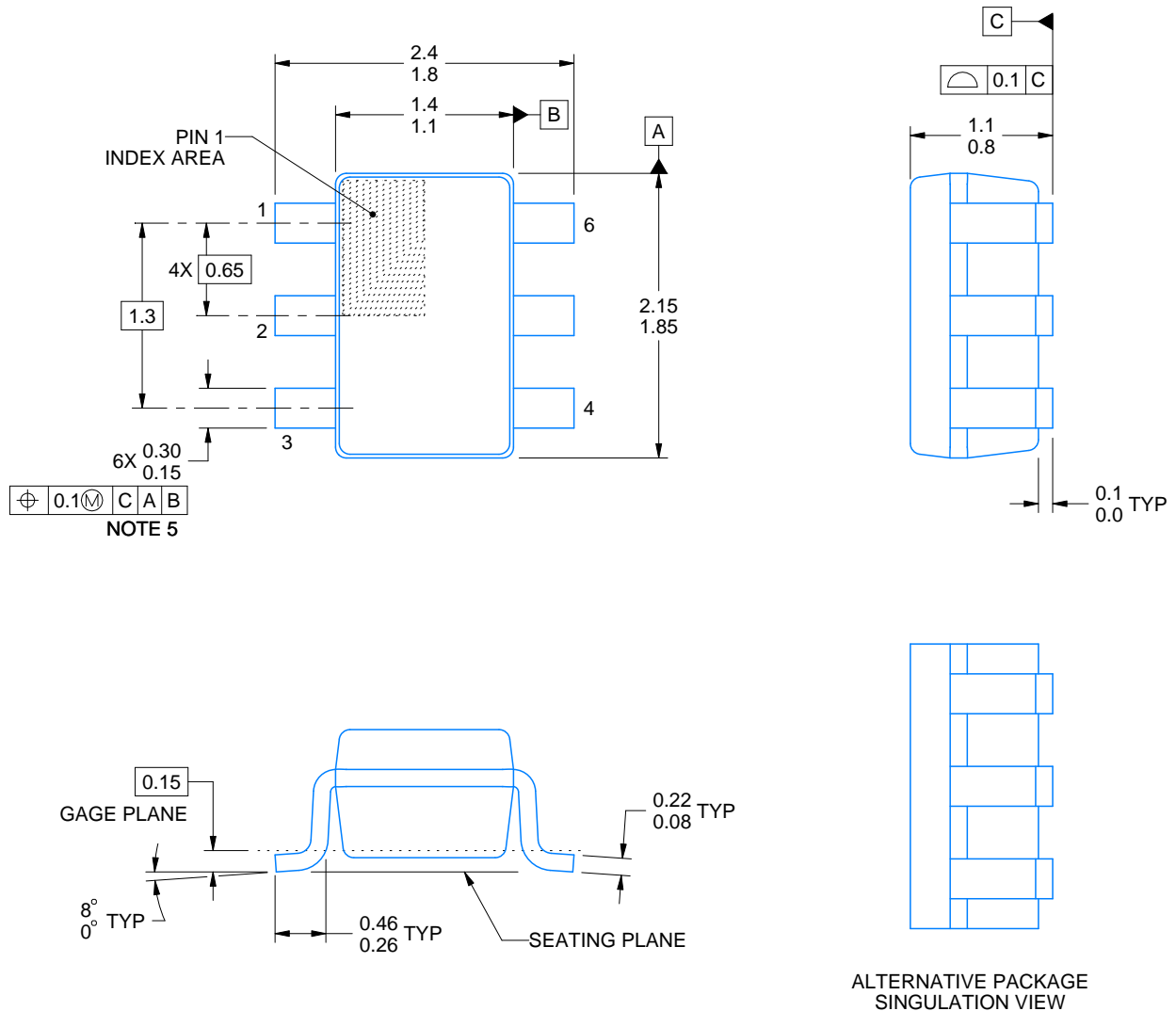

4214835/B 04/2024

NOTES:

1. All linear dimensions are in millimeters. Any dimensions in parenthesis are for reference only. Dimensioning and tolerancing per ASME Y14.5M.
2. This drawing is subject to change without notice.
3. Body dimensions do not include mold flash or protrusion. Mold flash and protrusion shall not exceed 0.15 per side.
4. Falls within JEDEC MO-203 variation AB.

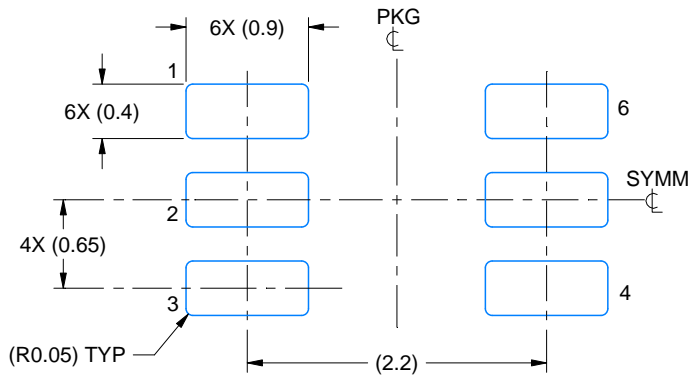

LAND PATTERN EXAMPLE
EXPOSED METAL SHOWN
SCALE:18X

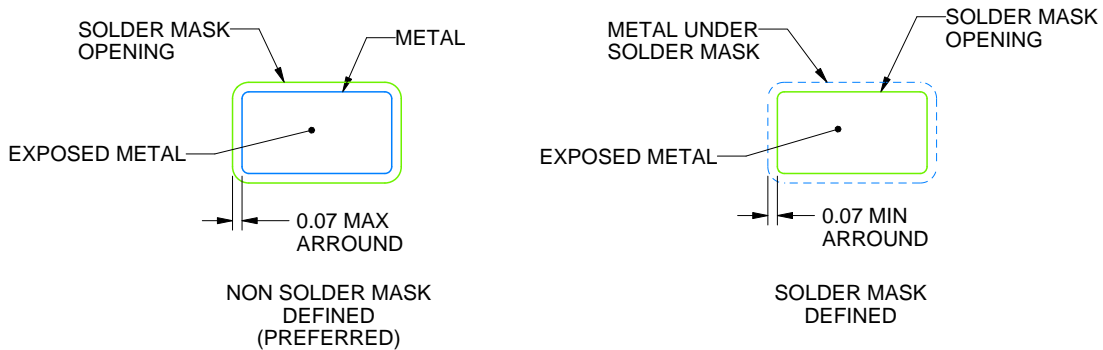

SOLDER MASK DETAILS

4214835/B 04/2024

NOTES: (continued)

- 5. Publication IPC-7351 may have alternate designs.
- 6. Solder mask tolerances between and around signal pads can vary based on board fabrication site.

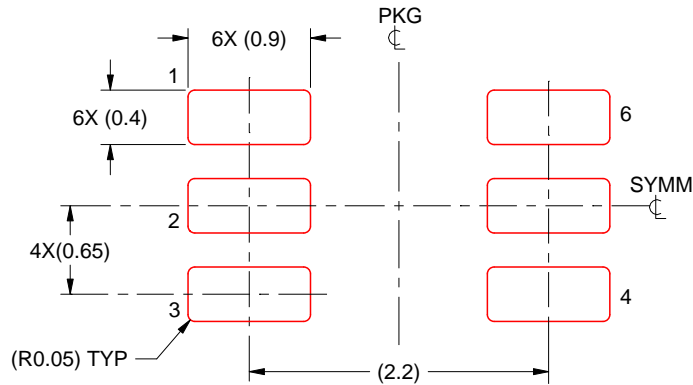

SOLDER PASTE EXAMPLE
BASED ON 0.125 THICK STENCIL
SCALE:18X

4214835/B 04/2024

NOTES: (continued)

7. Laser cutting apertures with trapezoidal walls and rounded corners may offer better paste release. IPC-7525 may have alternate design recommendations.
8. Board assembly site may have different recommendations for stencil design.

IMPORTANT NOTICE AND DISCLAIMER

TI PROVIDES TECHNICAL AND RELIABILITY DATA (INCLUDING DATA SHEETS), DESIGN RESOURCES (INCLUDING REFERENCE DESIGNS), APPLICATION OR OTHER DESIGN ADVICE, WEB TOOLS, SAFETY INFORMATION, AND OTHER RESOURCES "AS IS" AND WITH ALL FAULTS, AND DISCLAIMS ALL WARRANTIES, EXPRESS AND IMPLIED, INCLUDING WITHOUT LIMITATION ANY IMPLIED WARRANTIES OF MERCHANTABILITY, FITNESS FOR A PARTICULAR PURPOSE OR NON-INFRINGEMENT OF THIRD PARTY INTELLECTUAL PROPERTY RIGHTS.

These resources are intended for skilled developers designing with TI products. You are solely responsible for (1) selecting the appropriate TI products for your application, (2) designing, validating and testing your application, and (3) ensuring your application meets applicable standards, and any other safety, security, regulatory or other requirements.

These resources are subject to change without notice. TI grants you permission to use these resources only for development of an application that uses the TI products described in the resource. Other reproduction and display of these resources is prohibited. No license is granted to any other TI intellectual property right or to any third party intellectual property right. TI disclaims responsibility for, and you will fully indemnify TI and its representatives against, any claims, damages, costs, losses, and liabilities arising out of your use of these resources.

TI's products are provided subject to [TI's Terms of Sale](#) or other applicable terms available either on [ti.com](https://www.ti.com) or provided in conjunction with such TI products. TI's provision of these resources does not expand or otherwise alter TI's applicable warranties or warranty disclaimers for TI products.

TI objects to and rejects any additional or different terms you may have proposed.

Mailing Address: Texas Instruments, Post Office Box 655303, Dallas, Texas 75265
Copyright © 2024, Texas Instruments Incorporated

Looking for pricing, stock, or lifecycle information?

Click below to explore more details on WIN SOURCE:

 [View SN74LVC1G373DCKR on WIN SOURCE](#)

 [Texas Instruments](#) Information

Optimize Your Supply Chain with WIN SOURCE Solutions

-  Global Sourcing Solution
-  Obsolete Management
-  Cost Control Management
-  Shortage Management
-  Alternative Solution
-  Excess Inventory Management