



**THE DATASHEET OF  
SN74LVC16T245DLR**



# SN74LVC16T245 16-bit Dual-Supply Bus Transceiver

## With Configurable Level-Shifting / Voltage Translation and Tri-State Outputs

### 1 Features

- Control Inputs  $V_{IH}/V_{IL}$  Levels are Referenced to  $V_{CCA}$  Voltage
- $V_{CC}$  Isolation Feature – If Either  $V_{CC}$  Input is at GND, Both Ports are in the High-Impedance State
- Overvoltage-Tolerant Inputs and Outputs Allow Mixed Voltage-Mode Data Communications
- Fully Configurable Dual-Rail Design Allows Each Port to Operate Over the Full 1.65-V to 5.5-V Power-Supply Range
- $I_{off}$  Supports Partial-Power-Down Mode Operation
- Latch-Up Performance Exceeds 100 mA Per JESD 78, Class II
- ESD Protection Exceeds JESD 22

### 2 Applications

- Personal Electronics
- Industrial
- Enterprise
- Telecom

### 3 Description

This 16-bit noninverting bus transceiver uses two separate configurable power-supply rails. The A port is designed to track  $V_{CCA}$ .  $V_{CCA}$  accepts any supply voltage from 1.65 V to 5.5 V. The B port is designed to track  $V_{CCB}$ .  $V_{CCB}$  accepts any supply voltage from 1.65 V to 5.5 V. This allows for universal low-voltage bidirectional translation between any of the 1.8-V, 2.5-V, 3.3-V, and 5-V voltage nodes.

The SN74LVC16T245 device is designed for asynchronous communication between two data buses. The logic levels of the direction-control (DIR) input and the output-enable (OE) input activate either the B-port outputs or the A-port outputs or place both output ports into the high-impedance mode. The device transmits data from the A bus to the B bus when the B-port outputs are activated, and from the B bus to the A bus when the A-port outputs are activated. The input circuitry on both A and B ports always is active and must have a logic HIGH or LOW level applied to prevent excess  $I_{CC}$  and  $I_{CCZ}$ .

#### Device Information<sup>(1)</sup>

PART NUMBER	PACKAGE	BODY SIZE (NOM)
SN74LVC16T245	TSSOP (48)	12.50 mm × 6.10 mm
	TVSOP (48)	9.70 mm × 4.40 mm
	SSOP (48)	15.88 mm × 7.49 mm
	BGA MICROSTAR JUNIOR (56)	7.00 mm × 4.50 mm

(1) For all available packages, see the orderable addendum at the end of the data sheet.

#### Logic Diagram (Positive Logic)

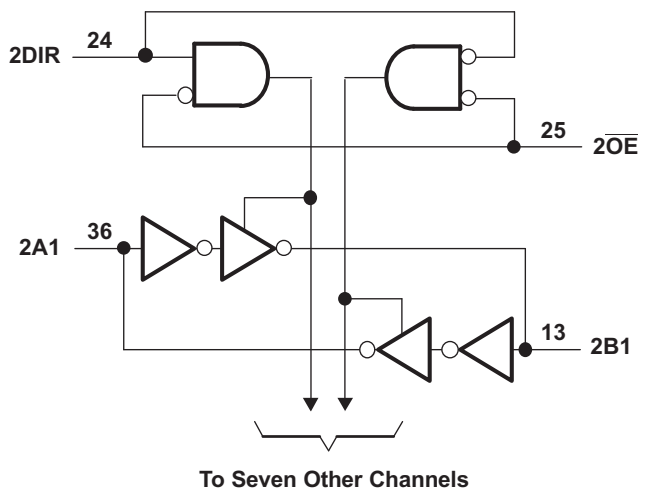
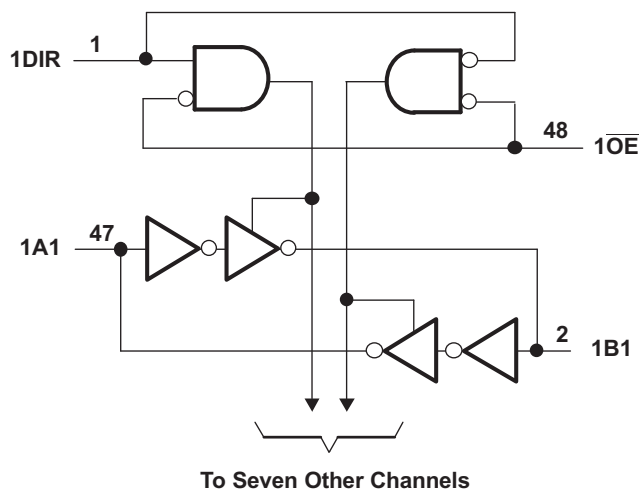

## Table of Contents

<b>1 Features</b> .....	<b>1</b>	<b>9 Detailed Description</b> .....	<b>13</b>
<b>2 Applications</b> .....	<b>1</b>	9.1 Overview .....	13
<b>3 Description</b> .....	<b>1</b>	9.2 Functional Block Diagram .....	13
<b>4 Revision History</b> .....	<b>2</b>	9.3 Feature Description .....	13
<b>5 Description (continued)</b> .....	<b>3</b>	9.4 Device Functional Modes .....	13
<b>6 Pin Configuration and Functions</b> .....	<b>4</b>	<b>10 Application and Implementation</b> .....	<b>15</b>
<b>7 Specifications</b> .....	<b>6</b>	10.1 Application Information .....	15
7.1 Absolute Maximum Ratings .....	6	10.2 Typical Application .....	16
7.2 ESD Ratings .....	6	<b>11 Power Supply Recommendations</b> .....	<b>18</b>
7.3 Recommended Operating Conditions .....	7	<b>12 Layout</b> .....	<b>18</b>
7.4 Thermal Information .....	8	12.1 Layout Guidelines .....	18
7.5 Electrical Characteristics .....	8	12.2 Layout Example .....	19
7.6 Switching Characteristics: $V_{CCA} = 1.8\text{ V} \pm 0.15\text{ V}$ .....	9	<b>13 Device and Documentation Support</b> .....	<b>20</b>
7.7 Switching Characteristics: $V_{CCA} = 2.5\text{ V} \pm 0.2\text{ V}$ .....	9	13.1 Documentation Support .....	20
7.8 Switching Characteristics: $V_{CCA} = 3.3\text{ V} \pm 0.3\text{ V}$ .....	10	13.2 Trademarks .....	20
7.9 Switching Characteristics: $V_{CCA} = 5\text{ V} \pm 0.5\text{ V}$ .....	10	13.3 Electrostatic Discharge Caution .....	20
7.10 Operating Characteristics .....	10	13.4 Glossary .....	20
7.11 Typical Characteristics .....	11	<b>14 Mechanical, Packaging, and Orderable Information</b> .....	<b>20</b>
<b>8 Parameter Measurement Information</b> .....	<b>12</b>		

## 4 Revision History

### Changes from Revision A (October 2005) to Revision B

Page

- Added *Pin Configuration and Functions* section, *ESD Ratings* table, *Feature Description* section, *Device Functional Modes*, *Application and Implementation* section, *Power Supply Recommendations* section, *Layout* section, *Device and Documentation Support* section, and *Mechanical, Packaging, and Orderable Information* section ..... 1

## 5 Description (continued)

The SN74LVC16T245 control pins (1DIR, 2DIR,  $\overline{1OE}$ , and  $\overline{2OE}$ ) are supplied by  $V_{CCA}$ .

This device is fully specified for partial-power-down applications using  $I_{off}$ . The  $I_{off}$  circuitry disables the outputs, preventing damaging current backflow through the device when it is powered down.

The  $V_{CC}$  isolation feature ensures that if either  $V_{CC}$  input is at GND, then both ports are in the high-impedance state. To ensure the high-impedance state during power up or power down,  $\overline{OE}$  should be tied to  $V_{CC}$  through a pullup resistor; the minimum value of the resistor is determined by the current-sinking capability of the driver.

## 6 Pin Configuration and Functions

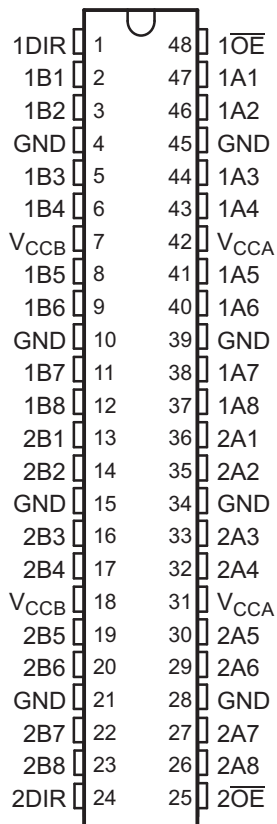
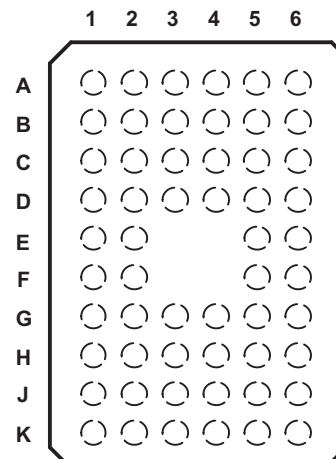
**DGG and DGV Packages  
48-Pin TSSOP and TVSOP  
(Top View)**

**GQL and ZQL Packages  
56-Pin BGA  
(Top View)**

### Pin Functions

PIN			I/O	DESCRIPTION
NAME	DGG / DGV	GQL / ZQL		
1A1	47	B5	I/O	Input/Output. Referenced to $V_{CCA}$
1A2	46	B6	I/O	Input/Output. Referenced to $V_{CCA}$
1A3	44	C5	I/O	Input/Output. Referenced to $V_{CCA}$
1A4	43	C6	I/O	Input/Output. Referenced to $V_{CCA}$
1A5	41	D5	I/O	Input/Output. Referenced to $V_{CCA}$
1A6	40	D6	I/O	Input/Output. Referenced to $V_{CCA}$
1A7	38	E5	I/O	Input/Output. Referenced to $V_{CCA}$
1A8	37	E6	I/O	Input/Output. Referenced to $V_{CCA}$
1B1	2	B2	I/O	Input/Output. Referenced to $V_{CCB}$
1B2	3	B1	I/O	Input/Output. Referenced to $V_{CCB}$
1B3	5	C2	I/O	Input/Output. Referenced to $V_{CCB}$
1B4	6	C1	I/O	Input/Output. Referenced to $V_{CCB}$
1B5	8	D2	I/O	Input/Output. Referenced to $V_{CCB}$
1B6	9	D1	I/O	Input/Output. Referenced to $V_{CCB}$
1B7	11	E2	I/O	Input/Output. Referenced to $V_{CCB}$
1B8	12	E1	I/O	Input/Output. Referenced to $V_{CCB}$
1DIR	1	A1	I	Direction-control signal

**Pin Functions (continued)**

PIN			I/O	DESCRIPTION
NAME	DGG / DGV	GQL / ZQL		
$\overline{1OE}$	48	A6	I	Tri-State output-mode enables. Pull $\overline{OE}$ high to place all outputs in Tri-State mode. Referenced to $V_{CCA}$
2A1	36	F6	I/O	Input/Output. Referenced to $V_{CCA}$
2A2	35	F5	I/O	Input/Output. Referenced to $V_{CCA}$
2A3	33	G6	I/O	Input/Output. Referenced to $V_{CCA}$
2A4	32	G5	I/O	Input/Output. Referenced to $V_{CCA}$
2A5	30	H6	I/O	Input/Output. Referenced to $V_{CCA}$
2A6	29	H5	I/O	Input/Output. Referenced to $V_{CCA}$
2A7	27	J6	I/O	Input/Output. Referenced to $V_{CCA}$
2A8	26	J5	I/O	Input/Output. Referenced to $V_{CCA}$
2B1	13	F1	I/O	Input/Output. Referenced to $V_{CCB}$
2B2	14	F2	I/O	Input/Output. Referenced to $V_{CCB}$
2B3	16	G1	I/O	Input/Output. Referenced to $V_{CCB}$
2B4	17	G2	I/O	Input/Output. Referenced to $V_{CCB}$
2B5	19	H1	I/O	Input/Output. Referenced to $V_{CCB}$
2B6	20	H2	I/O	Input/Output. Referenced to $V_{CCB}$
2B7	22	J1	I/O	Input/Output. Referenced to $V_{CCB}$
2B8	23	J2	I/O	Input/Output. Referenced to $V_{CCB}$
2DIR	24	K1	I	Direction-control signal
$\overline{2OE}$	25	K6	I	Tri-State output-mode enables. Pull $\overline{OE}$ high to place all outputs in Tri-State mode. Referenced to $V_{CCA}$
GND	4	B3	—	Ground
		B4		
	10	D3		
	15	D4		
	21	G3		
	28	G4		
	34	J3		
45	J4			
NC <sup>(1)</sup>	—	A2	—	
		A3		
		A4		
		A5		
		K2		
		K3		
		K4		
K5				
$V_{CCA}$	31	C4	—	A-port supply. $1.65\text{ V} \leq V_{CCA} \leq 5.5\text{ V}$
	42	H4		
$V_{CCB}$	7	C3	—	B-port supply. $1.65\text{ V} \leq V_{CCB} \leq 5.5\text{ V}$
	18	H3		

(1) NC – No internal connection

## 7 Specifications

### 7.1 Absolute Maximum Ratings

 over operating free-air temperature range (unless otherwise noted)<sup>(1)</sup>

		MIN	MAX	UNIT	
$V_{CCA}$ $V_{CCB}$	Supply voltage	-0.5	6.5	V	
$V_I$	Input voltage <sup>(2)</sup>	I/O ports (A port)	-0.5	6.5	V
		I/O ports (B port)	-0.5	6.5	
		Control inputs	-0.5	6.5	
$V_O$	Voltage applied to any output in the high-impedance or power-off state <sup>(2)</sup>	A port	-0.5	6.5	V
		B port	-0.5	6.5	
$V_O$	Voltage applied to any output in the high or low state <sup>(2)</sup> (3)	A port	-0.5	$V_{CCA} + 0.5$	V
		B port	-0.5	$V_{CCB} + 0.5$	
$I_{IK}$	Input clamp current	$V_I < 0$	-50	mA	
$I_{OK}$	Output clamp current	$V_O < 0$	-50	mA	
$I_O$	Continuous output current		±50	mA	
	Continuous current through each $V_{CCA}$ , $V_{CCB}$ , and GND		±100	mA	
$T_J$	Junction temperature	-40	150	°C	
$T_{stg}$	Storage temperature	-65	150	°C	

- (1) Stresses beyond those listed under *Absolute Maximum Ratings* may cause permanent damage to the device. These are stress ratings only, which do not imply functional operation of the device at these or any other conditions beyond those indicated under *Recommended Operating Conditions*. Exposure to absolute-maximum-rated conditions for extended periods may affect device reliability.
- (2) The input ( $V_I$ ) and output ( $V_O$ ) negative-voltage ratings may be exceeded if the input and output current ratings are observed.
- (3) The output positive-voltage rating may be exceeded up to 6.5 V maximum if the output current rating is observed.

### 7.2 ESD Ratings

		VALUE	UNIT
$V_{(ESD)}$	Electrostatic discharge	Human body model (HBM), per ANSI/ESDA/JEDEC JS-001 <sup>(1)</sup>	±2000
		Charged-device model (CDM), per JEDEC specification JESD22-C101 <sup>(2)</sup>	±1000
		Machine model (A115-A)	±200

- (1) JEDEC document JEP155 states that 500 V HBM allows safe manufacturing with a standard ESD control process.
- (2) JEDEC document JEP157 states that 250 V CDM allows safe manufacturing with a standard ESD control process.

### 7.3 Recommended Operating Conditions

 See <sup>(1)(2)(3)(4)</sup>

			$V_{CCI}$	$V_{CCO}$	MIN	MAX	UNIT
$V_{CCA}$	Supply voltage				1.65	5.5	V
$V_{CCB}$					1.65	5.5	
$V_{IH}$	High-level input voltage	Data inputs <sup>(5)</sup>	1.65 V to 1.95 V		$V_{CCI} \times 0.65$		V
			2.3 V to 2.7 V		1.7		
			3 V to 3.6 V		2		
			4.5 V to 5.5 V		$V_{CCI} \times 0.7$		
$V_{IL}$	Low-level input voltage	Data inputs <sup>(5)</sup>	1.65 V to 1.95 V			$V_{CCI} \times 0.35$	V
			2.3 V to 2.7 V			0.7	
			3 V to 3.6 V			0.8	
			4.5 V to 5.5 V			$V_{CCI} \times 0.3$	
$V_{IH}$	High-level input voltage	Control inputs (referenced to $V_{CCA}$ ) <sup>(6)</sup>	1.65 V to 1.95 V		$V_{CCA} \times 0.65$		V
			2.3 V to 2.7 V		1.7		
			3 V to 3.6 V		2		
			4.5 V to 5.5 V		$V_{CCA} \times 0.7$		
$V_{IL}$	Low-level input voltage	Control inputs (referenced to $V_{CCA}$ ) <sup>(6)</sup>	1.65 V to 1.95 V			$V_{CCA} \times 0.35$	V
			2.3 V to 2.7 V			0.7	
			3 V to 3.6 V			0.8	
			4.5 V to 5.5 V			$V_{CCA} \times 0.3$	
$V_I$	Input voltage	Control inputs			0	5.5	V
$V_{I/O}$	Input/output voltage	Active state			0	$V_{CCO}$	V
		Tri-State			0	5.5	
$I_{OH}$	High-level output current		1.65 V to 1.95 V			-4	mA
			2.3 V to 2.7 V			-8	
			3 V to 3.6 V			-24	
			4.5 V to 5.5 V			-32	
$I_{OL}$	Low-level output current		1.65 V to 1.95 V			4	mA
			2.3 V to 2.7 V			8	
			3 V to 3.6 V			24	
			4.5 V to 5.5 V			32	
$\Delta t/\Delta v$	Input transition rise or fall rate	Data inputs	1.65 V to 1.95 V			20	ns/V
			2.3 V to 2.7 V			20	
			3 V to 3.6 V			10	
			4.5 V to 5.5 V			5	
$T_A$	Operating free-air temperature				-40	85	°C

- (1)  $V_{CCI}$  is the  $V_{CC}$  associated with the input port.
- (2)  $V_{CCO}$  is the  $V_{CC}$  associated with the output port.
- (3) All unused or driven (floating) data inputs (I/Os) of the device must be held at logic HIGH or LOW (preferably  $V_{CCI}$  or GND) to ensure proper device operation and minimize power. Refer to the TI application report, *Implications of Slow or Floating CMOS Inputs*, literature number [SCBA004](#).
- (4) All unused data inputs of the device must be held at  $V_{CCA}$  or GND to ensure proper device operation.
- (5) For  $V_{CCI}$  values not specified in the data sheet,  $V_{IH}$  min =  $V_{CCI} \times 0.7$  V,  $V_{IL}$  max =  $V_{CCI} \times 0.3$  V.
- (6) For  $V_{CCA}$  values not specified in the data sheet,  $V_{IH}$  min =  $V_{CCA} \times 0.7$  V,  $V_{IL}$  max =  $V_{CCA} \times 0.3$  V.

## 7.4 Thermal Information

THERMAL METRIC <sup>(1)</sup>		SN74LVC16T245				UNIT
		DL (SSOP)	DGG (TSSOP)	DGV (TVSOP)	GQL / ZQL (BGA)	
		48 PINS	48 PINS	48 PINS	56 PINS	
$R_{\theta JA}$	Junction-to-ambient thermal resistance	92.9	60	82.5	64.6	°C/W
$R_{\theta JC(top)}$	Junction-to-case (top) thermal resistance	29.5	13.9	34.2	16.6	°C/W
$R_{\theta JB}$	Junction-to-board thermal resistance	35.5	27.1	45.1	30.8	°C/W
$\Psi_{JT}$	Junction-to-top characterization parameter	8.1	0.5	2.7	0.9	°C/W
$\Psi_{JB}$	Junction-to-board characterization parameter	34.9	26.8	44.6	64.6	°C/W

(1) For more information about traditional and new thermal metrics, see the *Semiconductor and IC Package Thermal Metrics* application report, [SPRA953](#).

## 7.5 Electrical Characteristics

over recommended operating free-air temperature range (unless otherwise noted)<sup>(1) (2)</sup>

PARAMETER	TEST CONDITIONS	$V_{CCA}$	$V_{CCB}$	$T_A = 25^\circ\text{C}$			$T_A = -40^\circ\text{C to } 85^\circ\text{C}$		UNIT
				MIN	TYP	MAX	MIN	MAX	
$V_{OH}$	$I_{OH} = -100 \mu\text{A}, V_I = V_{IH}$	1.65 V to 4.5 V	1.65 V to 4.5 V				$V_{CCO} - 0.1$		V
	$I_{OH} = -4 \text{ mA}, V_I = V_{IH}$	1.65 V	1.65 V				1.2		
	$I_{OH} = -8 \text{ mA}, V_I = V_{IH}$	2.3 V	2.3 V				1.9		
	$I_{OH} = -24 \text{ mA}, V_I = V_{IH}$	3 V	3 V				2.4		
	$I_{OH} = -32 \text{ mA}, V_I = V_{IH}$	4.5 V	4.5 V				3.8		
$V_{OL}$	$I_{OL} = 100 \mu\text{A}, V_I = V_{IL}$	1.65 V to 4.5 V	1.65 V to 4.5 V					0.1	V
	$I_{OL} = 4 \text{ mA}, V_I = V_{IL}$	1.65 V	1.65 V					0.45	
	$I_{OL} = 8 \text{ mA}, V_I = V_{IL}$	2.3 V	2.3 V					0.3	
	$I_{OL} = 24 \text{ mA}, V_I = V_{IL}$	3 V	3 V					0.55	
	$I_{OL} = 32 \text{ mA}, V_I = V_{IL}$	4.5 V	4.5 V					0.55	
$I_I$	Control inputs $V_I = V_{CCA}$ or GND	1.65 V to 5.5 V	1.65 V to 5.5 V			$\pm 1$		$\pm 2$	$\mu\text{A}$
$I_{off}$	A or B port $V_I$ or $V_O = 0$ to 5.5 V	0 V	0 to 5.5 V			$\pm 1$		$\pm 2$	$\mu\text{A}$
		0 to 5.5 V	0 V			$\pm 1$		$\pm 2$	
$I_{OZ}$	A or B port $V_O = V_{CCO}$ or GND, $\overline{OE} = V_{IH}$	1.65 V to 5.5 V	1.65 V to 5.5 V			$\pm 1$		$\pm 2$	$\mu\text{A}$
$I_{CCA}$	$V_I = V_{CCI}$ or GND, $I_O = 0$	1.65 V to 5.5 V	1.65 V to 5.5 V					20	$\mu\text{A}$
		5 V	0 V					20	
		0 V	5 V					-2	
$I_{CCB}$	$V_I = V_{CCI}$ or GND, $I_O = 0$	1.65 V to 5.5 V	1.65 V to 5.5 V					20	$\mu\text{A}$
		5 V	0 V					-2	
		0 V	5 V					20	
$I_{CCA} + I_{CCB}$	$V_I = V_{CCI}$ or GND, $I_O = 0$	1.65 V to 5.5 V	1.65 V to 5.5 V					30	$\mu\text{A}$
$\Delta I_{CCA}$	A port	3 V to 5.5 V	3 V to 5.5 V	One A port at $V_{CCA} - 0.6 \text{ V}$ , DIR at $V_{CCA}$ , B port = open				50	$\mu\text{A}$
	DIR			DIR at $V_{CCA} - 0.6 \text{ V}$ , B port = open, A port at $V_{CCA}$ or GND				50	
$\Delta I_{CCB}$	B port	3 V to 5.5 V	3 V to 5.5 V	One B port at $V_{CCB} - 0.6 \text{ V}$ , DIR at GND, A port = open				50	$\mu\text{A}$
$C_i$	Control inputs $V_I = V_{CCA}$ or GND	3.3 V	3.3 V			4		5	pF

(1)  $V_{CCO}$  is the  $V_{CC}$  associated with the output port.

(2)  $V_{CCI}$  is the  $V_{CC}$  associated with the input port.

## Electrical Characteristics (continued)

over recommended operating free-air temperature range (unless otherwise noted)<sup>(1) (2)</sup>

PARAMETER		TEST CONDITIONS	V <sub>CCA</sub>	V <sub>CCB</sub>	T <sub>A</sub> = 25°C			T <sub>A</sub> = -40°C to 85°C		UNIT
					MIN	TYP	MAX	MIN	MAX	
C <sub>io</sub>	A or B port	V <sub>O</sub> = V <sub>CCA/B</sub> or GND	3.3 V	3.3 V	8.5			10		pF

### 7.6 Switching Characteristics: V<sub>CCA</sub> = 1.8 V ±0.15 V

over recommended operating free-air temperature range, V<sub>CCA</sub> = 1.8 V ± 0.15 V (unless otherwise noted) (see [Figure 3](#))

PARAMETER	FROM (INPUT)	TO (OUTPUT)	V <sub>CCB</sub> = 1.8 V ±0.15 V		V <sub>CCB</sub> = 2.5 V ±0.2 V		V <sub>CCB</sub> = 3.3 V ±0.3 V		V <sub>CCB</sub> = 5 V ±0.5 V		UNIT
			MIN	MAX	MIN	MAX	MIN	MAX	MIN	MAX	
t <sub>PLH</sub>	A	B	1.7	21.9	1.3	9.2	1	7.4	0.8	7.1	ns
t <sub>PHL</sub>											
t <sub>PLH</sub>	B	A	0.9	23.8	0.8	23.6	0.7	23.4	0.7	23.4	ns
t <sub>PHL</sub>											
t <sub>PHZ</sub>	$\overline{OE}$	A	1.6	29.6	1.5	29.4	1.5	29.3	1.4	29.2	ns
t <sub>PLZ</sub>											
t <sub>PHZ</sub>	$\overline{OE}$	B	2.4	32.2	1.9	13.1	1.7	12	1.3	10.3	ns
t <sub>PLZ</sub>											
t <sub>PZH</sub>	$\overline{OE}$	A	0.4	24	0.4	23.8	0.4	23.7	0.4	23.7	ns
t <sub>PZL</sub>											
t <sub>PZH</sub>	$\overline{OE}$	B	1.8	32	1.6	16	1.2	12.6	0.9	10.8	ns
t <sub>PZL</sub>											

### 7.7 Switching Characteristics: V<sub>CCA</sub> = 2.5 V ±0.2 V

over recommended operating free-air temperature range, V<sub>CCA</sub> = 2.5 V ± 0.2 V (unless otherwise noted) (see [Figure 3](#))

PARAMETER	FROM (INPUT)	TO (OUTPUT)	V <sub>CCB</sub> = 1.8 V ±0.15 V		V <sub>CCB</sub> = 2.5 V ±0.2 V		V <sub>CCB</sub> = 3.3 V ±0.3 V		V <sub>CCB</sub> = 5 V 0.5 V		UNIT
			MIN	MAX	MIN	MAX	MIN	MAX	MIN	MAX	
t <sub>PLH</sub>	A	B	1.6	21.4	1.2	9	0.8	6.2	0.6	4.8	ns
t <sub>PHL</sub>											
t <sub>PLH</sub>	B	A	1.2	9.3	1	9.1	1	8.9	0.9	8.8	ns
t <sub>PHL</sub>											
t <sub>PHZ</sub>	$\overline{OE}$	A	1.4	9	1.4	9	1.4	9	1.4	9	ns
t <sub>PLZ</sub>											
t <sub>PHZ</sub>	$\overline{OE}$	B	2.3	29.6	1.8	11	1.7	9.3	0.9	6.9	ns
t <sub>PLZ</sub>											
t <sub>PZH</sub>	$\overline{OE}$	A	1	10.9	1	10.9	1	10.9	1	10.9	ns
t <sub>PZL</sub>											
t <sub>PZH</sub>	$\overline{OE}$	B	1.7	28.2	1.6	12.9	1.2	9.4	1	6.9	ns
t <sub>PZL</sub>											

### 7.8 Switching Characteristics: $V_{CCA} = 3.3\text{ V} \pm 0.3\text{ V}$

 over recommended operating free-air temperature range,  $V_{CCA} = 3.3\text{ V} \pm 0.3\text{ V}$  (unless otherwise noted) (see [Figure 3](#))

PARAMETER	FROM (INPUT)	TO (OUTPUT)	$V_{CCB} = 1.8\text{ V} \pm 0.15\text{ V}$		$V_{CCB} = 2.5\text{ V} \pm 0.2\text{ V}$		$V_{CCB} = 3.3\text{ V} \pm 0.3\text{ V}$		$V_{CCB} = 5\text{ V} \pm 0.5\text{ V}$		UNIT
			MIN	MAX	MIN	MAX	MIN	MAX	MIN	MAX	
$t_{PLH}$	A	B	1.5	21.2	1.1	8.8	0.8	6.1	0.5	4.4	ns
$t_{PHL}$											
$t_{PLH}$	B	A	0.9	7.2	0.8	6.2	0.7	6.1	0.6	6	ns
$t_{PHL}$											
$t_{PHZ}$	$\overline{OE}$	A	1.6	8.2	1.6	8.2	1.6	6.2	1.6	8.2	ns
$t_{PLZ}$											
$t_{PHZ}$	$\overline{OE}$	B	2.1	29	1.7	10.3	1.5	8.6	0.8	6.3	ns
$t_{PLZ}$											
$t_{PZH}$	$\overline{OE}$	A	0.8	7.8	0.8	7.8	0.8	7.8	0.8	7.8	ns
$t_{PZL}$											
$t_{PZH}$	$\overline{OE}$	B	1.6	27.7	1.4	12.4	1.1	8.5	0.9	8.4	ns
$t_{PZL}$											

### 7.9 Switching Characteristics: $V_{CCA} = 5\text{ V} \pm 0.5\text{ V}$

 over recommended operating free-air temperature range,  $V_{CCA} = 5\text{ V} \pm 0.5\text{ V}$  (unless otherwise noted) (see [Figure 3](#))

PARAMETER	FROM (INPUT)	TO (OUTPUT)	$V_{CC} = 1.8\text{ V} \pm 0.15\text{ V}$		$V_{CC} = 2.5\text{ V} \pm 0.2\text{ V}$		$V_{CC} = 3.3\text{ V} \pm 0.3\text{ V}$		$V_{CC} = 5\text{ V} \pm 0.5\text{ V}$		UNIT
			MIN	MAX	MIN	MAX	MIN	MAX	MIN	MAX	
$t_{PLH}$	A	B	1.6	21.4	1	8.8	0.7	6	0.4	4.2	ns
$t_{PHL}$											
$t_{PLH}$	B	A	0.7	6.8	0.4	4.8	0.3	4.5	0.3	4.3	ns
$t_{PHL}$											
$t_{PHZ}$	$\overline{OE}$	A	0.3	5.4	0.3	5.4	0.3	5.4	0.3	6.4	ns
$t_{PLZ}$											
$t_{PHZ}$	$\overline{OE}$	B	2	28.7	1.6	9.7	1.4	8	0.7	5.7	ns
$t_{PLZ}$											
$t_{PZH}$	$\overline{OE}$	A	0.7	5.5	0.7	5.5	0.7	5.5	0.7	5.5	ns
$t_{PZL}$											
$t_{PZH}$	$\overline{OE}$	B	1.6	27.6	1.3	11.4	1	8.1	0.9	6	ns
$t_{PZL}$											

### 7.10 Operating Characteristics

 $T_A = 25^\circ\text{C}$ 

PARAMETER		TEST CONDITIONS	$V_{CCA} = V_{CCB} = 1.8\text{ V}$	$V_{CCA} = V_{CCB} = 2.5\text{ V}$	$V_{CCA} = V_{CCB} = 3.3\text{ V}$	$V_{CCA} = V_{CCB} = 5\text{ V}$	UNIT
			TYP	TYP	TYP	TYP	
$C_{pdA}$ (1)	A-port input, B-port output	$C_L = 0$ , $f = 10\text{ MHz}$ , $t_r = t_f = 1\text{ ns}$	2	2	2	3	pF
	B-port input, A-port output		18	19	19	22	
$C_{pdB}$ (1)	A-port input, B-port output		18	19	20	22	
	B-port input, A-port output		2	2	2	2	

 (1) Power dissipation capacitance per transceiver. Refer to the TI application report, *CMOS Power Consumption and Cpd Calculation*, [SCAA035](#)

**7.11 Typical Characteristics**

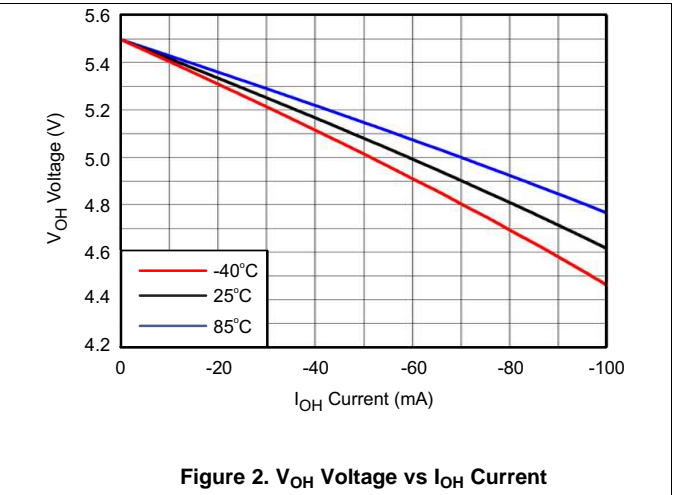
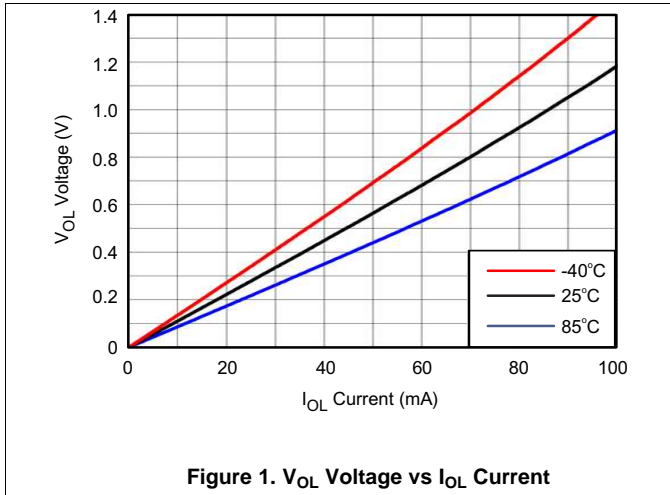

## 8 Parameter Measurement Information

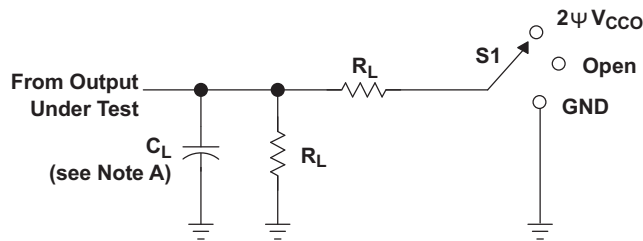
**LOAD CIRCUIT**

TEST	S1
$t_{pd}$	Open
$t_{PLZ}/t_{PZL}$	$2\psi V_{CCO}$
$t_{PHZ}/t_{PZH}$	GND

$V_{CCO}$	$C_L$	$R_L$	$V_{TP}$
$1.8\text{ V} \pm 0.15\text{ V}$	15 pF	2 k $\Omega$	0.15 V
$2.5\text{ V} \pm 0.2\text{ V}$	15 pF	2 k $\Omega$	0.15 V
$3.3\text{ V} \pm 0.3\text{ V}$	15 pF	2 k $\Omega$	0.3 V
$5\text{ V} \pm 0.5\text{ V}$	15 pF	2 k $\Omega$	0.3 V

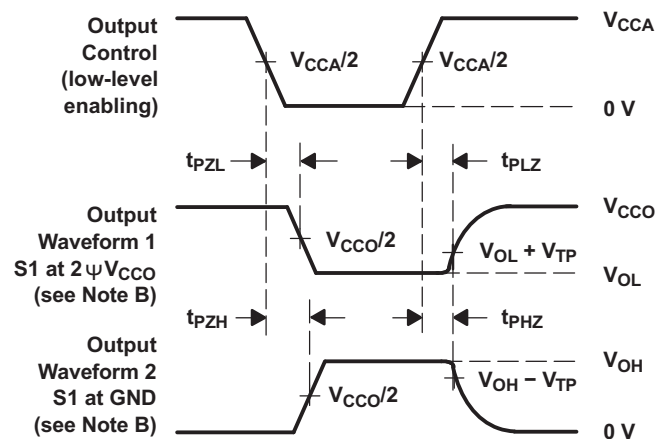
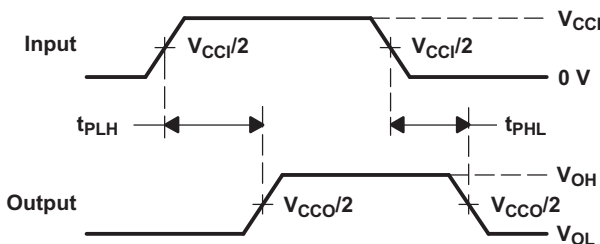
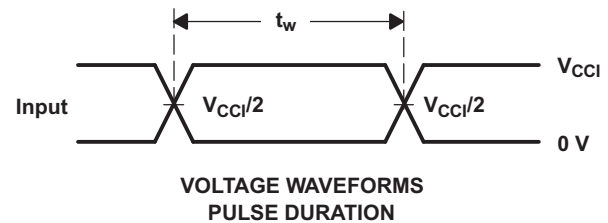

- NOTES:
- A.  $C_L$  includes probe and jig capacitance.
  - B. Waveform 1 is for an output with internal conditions such that the output is low except when disabled by the output control. Waveform 2 is for an output with internal conditions such that the output is high, except when disabled by the output control.
  - C. All input pulses are supplied by generators having the following characteristics: PRR = 10 MHz,  $Z_O = 50\ \Omega$ ,  $dv/dt \geq 1\text{ V/ns}$ .
  - D. The outputs are measured one at a time, with one transition per measurement.
  - E.  $t_{PLH}$  and  $t_{PHL}$  are the same as  $t_{pd}$ .
  - F.  $V_{CCI}$  is the  $V_{CC}$  associated with the input port.
  - G.  $V_{CCO}$  is the  $V_{CC}$  associated with the output port.
  - H. All parameters and waveforms are not applicable to all devices.

**Figure 3. Load Circuit and Voltage Waveforms**

## 9 Detailed Description

### 9.1 Overview

The SN74LVC16T245 is a 16-bit, dual-supply noninverting bidirectional voltage level translation. Pins A and control pins (DIR and  $\overline{OE}$ ) are supported by  $V_{CCA}$  and pins B are supported by  $V_{CCB}$ . The A port is able to accept I/O voltages ranging from 1.65 V to 5.5 V, while the B port can accept I/O voltages from 1.65 V to 5.5 V. A high on DIR allows data transmission from A to B and a low on DIR allows data transmission from B to A when  $\overline{OE}$  is set to low. When  $\overline{OE}$  is set to high, both A and B are in the high-impedance state.

This device is fully specified for partial-power-down applications using off output current ( $I_{off}$ ).

The  $V_{CC}$  isolation feature ensures that if either  $V_{CC}$  input is at GND, both ports are put in a high-impedance state.

### 9.2 Functional Block Diagram

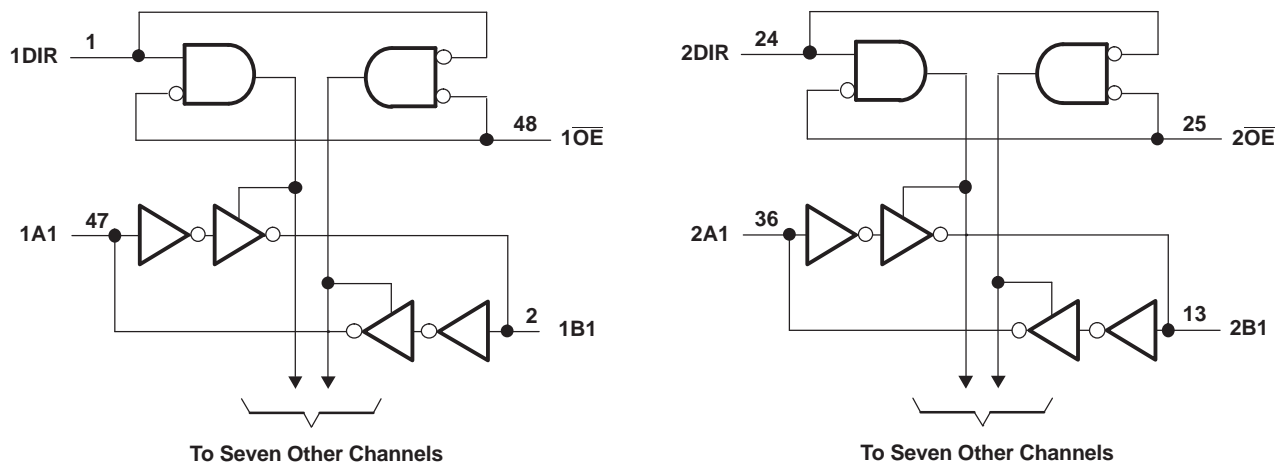

### 9.3 Feature Description

#### 9.3.1 Fully Configurable Dual-Rail Design Allows Each Port to Operate Over the Full 1.65-V to 5.5-V Power-Supply Range

Both  $V_{CCA}$  and  $V_{CCB}$  can be supplied at any voltage from 1.65 V to 5.5 V making the device suitable for translating between any of the low voltage nodes (1.8-V, 2.5-V, and 3.3-V).

#### 9.3.2 Support High-Speed Translation

SN74LVC16T245 can support high data rate application. Data rates can be calculated from the maximum propagation delay. This is also dependant on the output load. For example, for a 3.3-V to 5-V conversion, the maximum frequency is 200 MHz.

#### 9.3.3 Partial-Power-Down Mode Operation

This device is fully specified for partial-power-down applications using off output current ( $I_{off}$ ).  $I_{off}$  will prevent backflow current by disabling I/O output circuits when device is in partial power-down mode.

#### 9.3.4 $V_{CC}$ Isolation

The  $V_{CC}$  isolation feature ensures that if either  $V_{CCA}$  or  $V_{CCB}$  are at GND, both ports will be in a high-impedance state ( $I_{OZ}$  shown in [Electrical Characteristics](#)). This prevents false logic levels from being presented to either bus.

### 9.4 Device Functional Modes

The functional modes for the SN74LVC16T245 device are shown in [Table 1](#).

**Table 1. Function Table<sup>(1)</sup>  
(Each Transceiver)**

CONTROL INPUTS		OUTPUT CIRCUITS		OPERATION
$\overline{\text{OE}}$	DIR	A PORT	B PORT	
L	L	Enabled	Hi-Z	B data to A bus
L	H	Hi-Z	Enabled	A data to B bus
H	X	Hi-Z	Hi-Z	Isolation

(1) Input circuits of the data I/Os always are active.

## 10 Application and Implementation

### NOTE

Information in the following applications sections is not part of the TI component specification, and TI does not warrant its accuracy or completeness. TI's customers are responsible for determining suitability of components for their purposes. Customers should validate and test their design implementation to confirm system functionality.

### 10.1 Application Information

The SN74LVC16T245 device can be used in level-shifting applications for interfacing devices and addressing mixed voltage incompatibility. The SN74LVC16T245 device is ideal for data transmission where direction is different for each channel.

#### 10.1.1 Enable Times

Calculate the enable times for the SN74LV16T245 using the following formulas:

$$t_{PZH} \text{ (DIR to A)} = t_{PLZ} \text{ (DIR to B)} + t_{PLH} \text{ (B to A)} \quad (1)$$

$$t_{PZL} \text{ (DIR to A)} = t_{PHZ} \text{ (DIR to B)} + t_{PHL} \text{ (B to A)} \quad (2)$$

$$t_{PZH} \text{ (DIR to B)} = t_{PLZ} \text{ (DIR to A)} + t_{PLH} \text{ (A to B)} \quad (3)$$

$$t_{PZL} \text{ (DIR to B)} = t_{PHZ} \text{ (DIR to A)} + t_{PHL} \text{ (A to B)} \quad (4)$$

In a bidirectional application, these enable times provide the maximum delay from the time the DIR bit is switched until an output is expected. For example, if the SN74LVC16T245 initially is transmitting from A to B, then the DIR bit is switched; the B port of the device must be disabled before presenting it with an input. After the B port has been disabled, an input signal applied to it appears on the corresponding A port after the specified propagation delay.

## 10.2 Typical Application

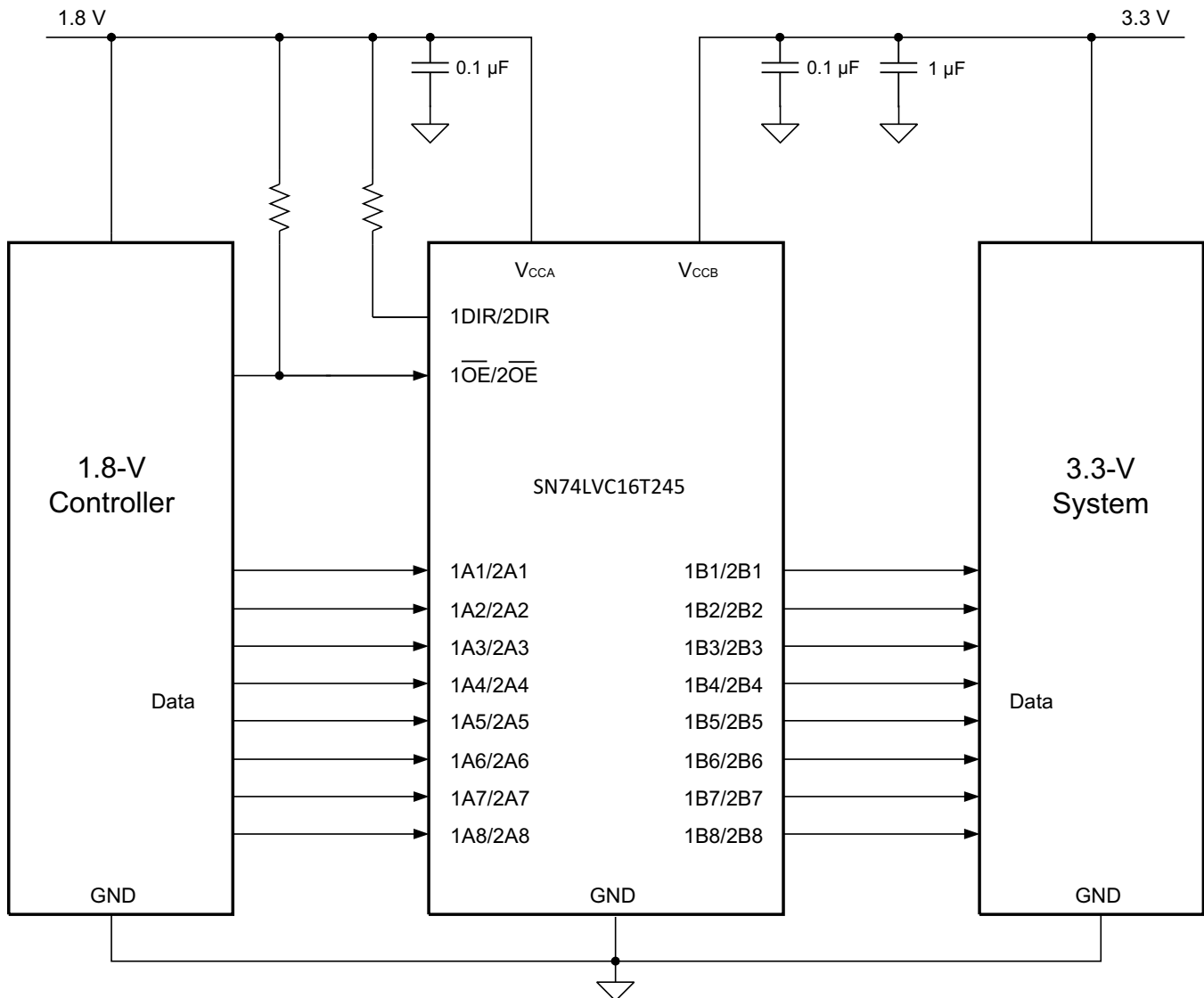

**Figure 4. Typical Application Schematic**

### 10.2.1 Design Requirements

This device uses drivers which are enabled depending on the state of the DIR pin. The designer must know the intended flow of data and take care not to violate any of the high or low logic levels. It is important that unused data inputs not be floating, as this can cause excessive internal leakage on the input CMOS structure. Make sure to tie any unused input and output ports directly to ground. For this design example, use the parameters listed in [Table 2](#).

**Table 2. Design Parameters**

DESIGN PARAMETERS	EXAMPLE VALUE
Input voltage range	1.65 V to 5.5 V
Output voltage	1.65 V to 5.5 V

### 10.2.2 Detailed Design Procedure

To begin the design process, determine the following:

- Input voltage range
  - Use the supply voltage of the device that is driving the SN74LVC16T245 device to determine the input voltage range. For a valid logic high the value must exceed the  $V_{IH}$  of the input port. For a valid logic low the value must be less than the  $V_{IL}$  of the input port.
- Output voltage range
  - Use the supply voltage of the device that the SN74LVC16T245 device is driving to determine the output voltage range.

### 10.2.3 Application Curve

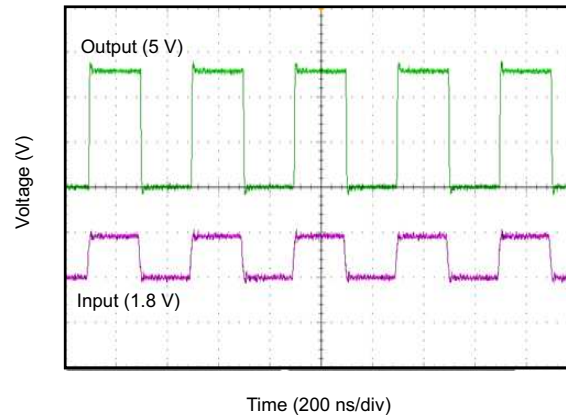

**Figure 5. Translation Up (1.8 V to 5 V) at 2.5 MHz**

## 11 Power Supply Recommendations

The SN74LVC16T245 device uses two separate configurable power-supply rails,  $V_{CCA}$  and  $V_{CCB}$ .  $V_{CCA}$  accepts any supply voltage from 1.65 V to 5.5 V and  $V_{CCB}$  accepts any supply voltage from 1.65 V to 5.5 V. The A port and B port are designed to track  $V_{CCA}$  and  $V_{CCB}$ , respectively, allowing for low-voltage bidirectional translation between any of the 1.8-V, 2.5-V and 3.3-V voltage nodes.

The output-enable  $\overline{OE}$  input circuit is supplied by  $V_{CCA}$  and when the  $\overline{OE}$  input is high, all outputs are placed in the high-impedance state. To ensure the high-impedance state of the outputs during power up or power down, the  $\overline{OE}$  input pin must be tied to  $V_{CCA}$  through a pullup resistor and must not be enabled until  $V_{CCA}$  and  $V_{CCB}$  are fully ramped and stable. The minimum value of the pullup resistor to  $V_{CCA}$  is determined by the current-sinking capability of the driver.

## 12 Layout

### 12.1 Layout Guidelines

To ensure reliability of the device, following common printed-circuit-board layout guidelines is recommended.

- Bypass capacitors should be used on power supplies.
- Short trace lengths should be used to avoid excessive loading.
- Placing pads on the signal paths for loading capacitors or pullup resistors to help adjust rise and fall times of signals depending on the system requirements.

## 12.2 Layout Example

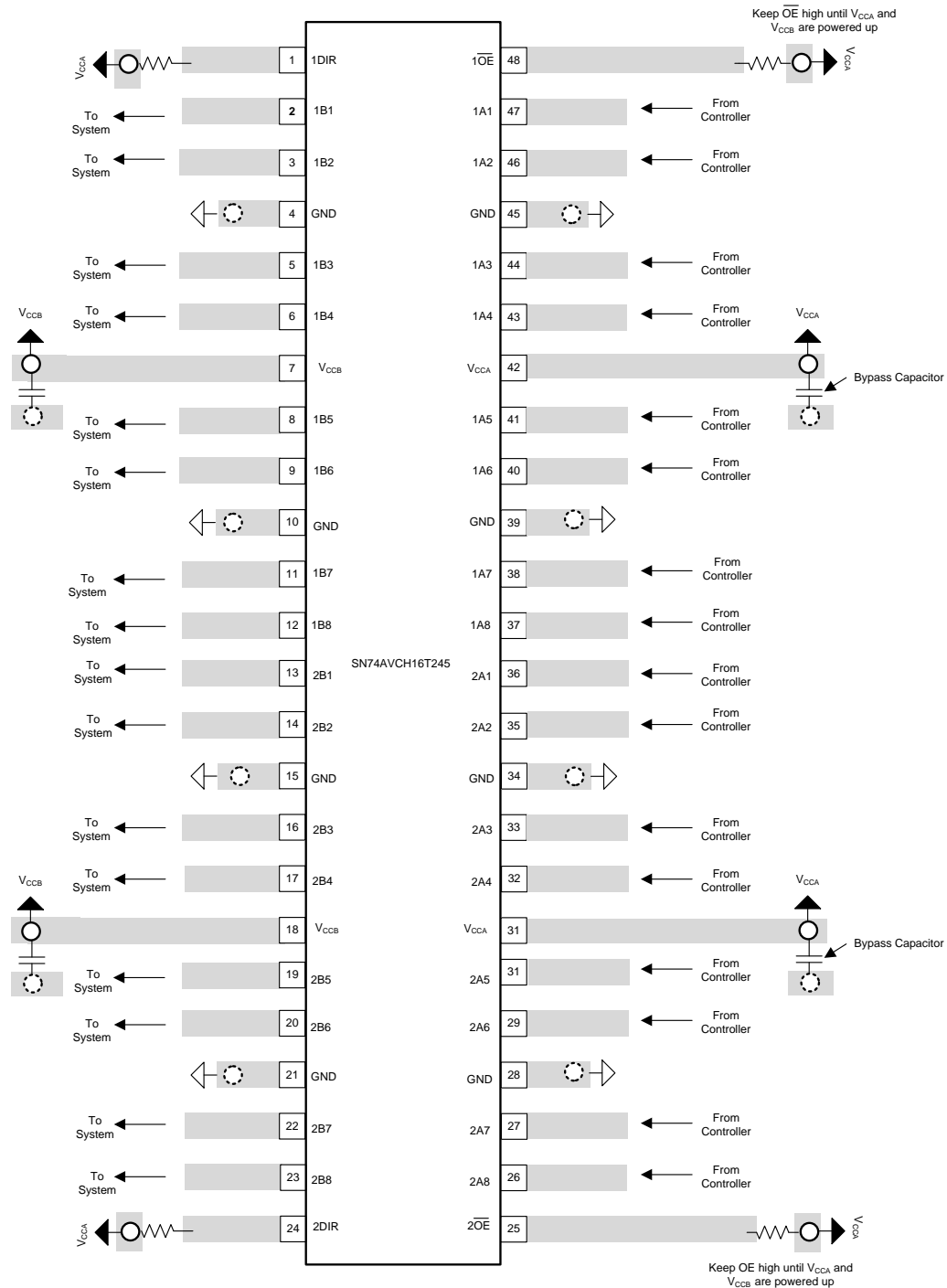
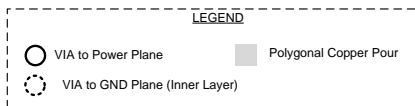

Figure 6. SN74LVC16T245 Layout Example

## 13 Device and Documentation Support

### 13.1 Documentation Support

#### 13.1.1 Related Documentation

For related documentation see the following:

- *CMOS Power Consumption and Cpd Calculation*, [SCAA035](#)
- *Implications of Slow or Floating CMOS Inputs*, [SCBA004](#)

### 13.2 Trademarks

All trademarks are the property of their respective owners.

### 13.3 Electrostatic Discharge Caution



These devices have limited built-in ESD protection. The leads should be shorted together or the device placed in conductive foam during storage or handling to prevent electrostatic damage to the MOS gates.

### 13.4 Glossary

[SLYZ022](#) — *TI Glossary*.

This glossary lists and explains terms, acronyms, and definitions.

## 14 Mechanical, Packaging, and Orderable Information

The following pages include mechanical, packaging, and orderable information. This information is the most current data available for the designated devices. This data is subject to change without notice and revision of this document. For browser-based versions of this data sheet, refer to the left-hand navigation.

**PACKAGING INFORMATION**

Orderable Device	Status (1)	Package Type	Package Drawing	Pins	Package Qty	Eco Plan (2)	Lead finish/ Ball material (6)	MSL Peak Temp (3)	Op Temp (°C)	Device Marking (4/5)	Samples
74LVC16T245DGGRE4	ACTIVE	TSSOP	DGG	48	2000	RoHS & Green	NIPDAU	Level-1-260C-UNLIM	-40 to 85	LVC16T245	<a href="#">Samples</a>
74LVC16T245DGGRG4	ACTIVE	TSSOP	DGG	48	2000	RoHS & Green	NIPDAU	Level-1-260C-UNLIM	-40 to 85	LVC16T245	<a href="#">Samples</a>
74LVC16T245DGVRG4	ACTIVE	TVSOP	DGV	48	2000	RoHS & Green	NIPDAU	Level-1-260C-UNLIM	-40 to 85	LDT245	<a href="#">Samples</a>
SN74LVC16T245DGGR	ACTIVE	TSSOP	DGG	48	2000	RoHS & Green	NIPDAU	Level-1-260C-UNLIM	-40 to 85	LVC16T245	<a href="#">Samples</a>
SN74LVC16T245DGVR	ACTIVE	TVSOP	DGV	48	2000	RoHS & Green	NIPDAU	Level-1-260C-UNLIM	-40 to 85	LDT245	<a href="#">Samples</a>
SN74LVC16T245DL	ACTIVE	SSOP	DL	48	25	RoHS & Green	NIPDAU	Level-1-260C-UNLIM	-40 to 85	LVC16T245	<a href="#">Samples</a>
SN74LVC16T245DLR	ACTIVE	SSOP	DL	48	1000	RoHS & Green	NIPDAU	Level-1-260C-UNLIM	-40 to 85	LVC16T245	<a href="#">Samples</a>

(1) The marketing status values are defined as follows:

**ACTIVE:** Product device recommended for new designs.

**LIFEBUY:** TI has announced that the device will be discontinued, and a lifetime-buy period is in effect.

**NRND:** Not recommended for new designs. Device is in production to support existing customers, but TI does not recommend using this part in a new design.

**PREVIEW:** Device has been announced but is not in production. Samples may or may not be available.

**OBSOLETE:** TI has discontinued the production of the device.

(2) **RoHS:** TI defines "RoHS" to mean semiconductor products that are compliant with the current EU RoHS requirements for all 10 RoHS substances, including the requirement that RoHS substance do not exceed 0.1% by weight in homogeneous materials. Where designed to be soldered at high temperatures, "RoHS" products are suitable for use in specified lead-free processes. TI may reference these types of products as "Pb-Free".

**RoHS Exempt:** TI defines "RoHS Exempt" to mean products that contain lead but are compliant with EU RoHS pursuant to a specific EU RoHS exemption.

**Green:** TI defines "Green" to mean the content of Chlorine (Cl) and Bromine (Br) based flame retardants meet JS709B low halogen requirements of <=1000ppm threshold. Antimony trioxide based flame retardants must also meet the <=1000ppm threshold requirement.

(3) MSL, Peak Temp. - The Moisture Sensitivity Level rating according to the JEDEC industry standard classifications, and peak solder temperature.

(4) There may be additional marking, which relates to the logo, the lot trace code information, or the environmental category on the device.

(5) Multiple Device Markings will be inside parentheses. Only one Device Marking contained in parentheses and separated by a "~" will appear on a device. If a line is indented then it is a continuation of the previous line and the two combined represent the entire Device Marking for that device.

<sup>(6)</sup> Lead finish/Ball material - Orderable Devices may have multiple material finish options. Finish options are separated by a vertical ruled line. Lead finish/Ball material values may wrap to two lines if the finish value exceeds the maximum column width.

**Important Information and Disclaimer:**The information provided on this page represents TI's knowledge and belief as of the date that it is provided. TI bases its knowledge and belief on information provided by third parties, and makes no representation or warranty as to the accuracy of such information. Efforts are underway to better integrate information from third parties. TI has taken and continues to take reasonable steps to provide representative and accurate information but may not have conducted destructive testing or chemical analysis on incoming materials and chemicals. TI and TI suppliers consider certain information to be proprietary, and thus CAS numbers and other limited information may not be available for release.

In no event shall TI's liability arising out of such information exceed the total purchase price of the TI part(s) at issue in this document sold by TI to Customer on an annual basis.

**OTHER QUALIFIED VERSIONS OF SN74LVC16T245 :**

- Enhanced Product: [SN74LVC16T245-EP](#)

NOTE: Qualified Version Definitions:

- Enhanced Product - Supports Defense, Aerospace and Medical Applications

**TAPE AND REEL INFORMATION**

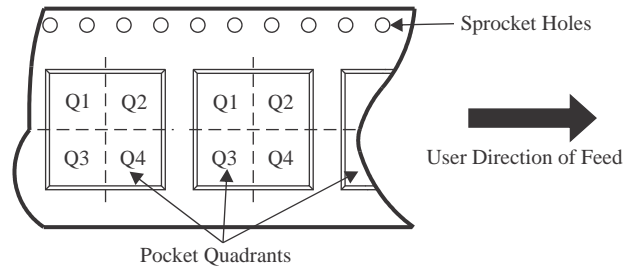
**QUADRANT ASSIGNMENTS FOR PIN 1 ORIENTATION IN TAPE**

\*All dimensions are nominal

Device	Package Type	Package Drawing	Pins	SPQ	Reel Diameter (mm)	Reel Width W1 (mm)	A0 (mm)	B0 (mm)	K0 (mm)	P1 (mm)	W (mm)	Pin1 Quadrant
SN74LVC16T245DGGR	TSSOP	DGG	48	2000	330.0	24.4	8.6	13.0	1.8	12.0	24.0	Q1
SN74LVC16T245DGVR	TVSOP	DGV	48	2000	330.0	16.4	7.1	10.2	1.6	12.0	16.0	Q1
SN74LVC16T245DLR	SSOP	DL	48	1000	330.0	32.4	11.35	16.2	3.1	16.0	32.0	Q1

**TAPE AND REEL BOX DIMENSIONS**

\*All dimensions are nominal

Device	Package Type	Package Drawing	Pins	SPQ	Length (mm)	Width (mm)	Height (mm)
SN74LVC16T245DGGR	TSSOP	DGG	48	2000	367.0	367.0	45.0
SN74LVC16T245DGVR	TVSOP	DGV	48	2000	356.0	356.0	35.0
SN74LVC16T245DLR	SSOP	DL	48	1000	367.0	367.0	55.0

**TUBE**



\*All dimensions are nominal

Device	Package Name	Package Type	Pins	SPQ	L (mm)	W (mm)	T (μm)	B (mm)
SN74LVC16T245DL	DL	SSOP	48	25	473.7	14.24	5110	7.87

# MECHANICAL DATA

DL (R-PDSO-G48)

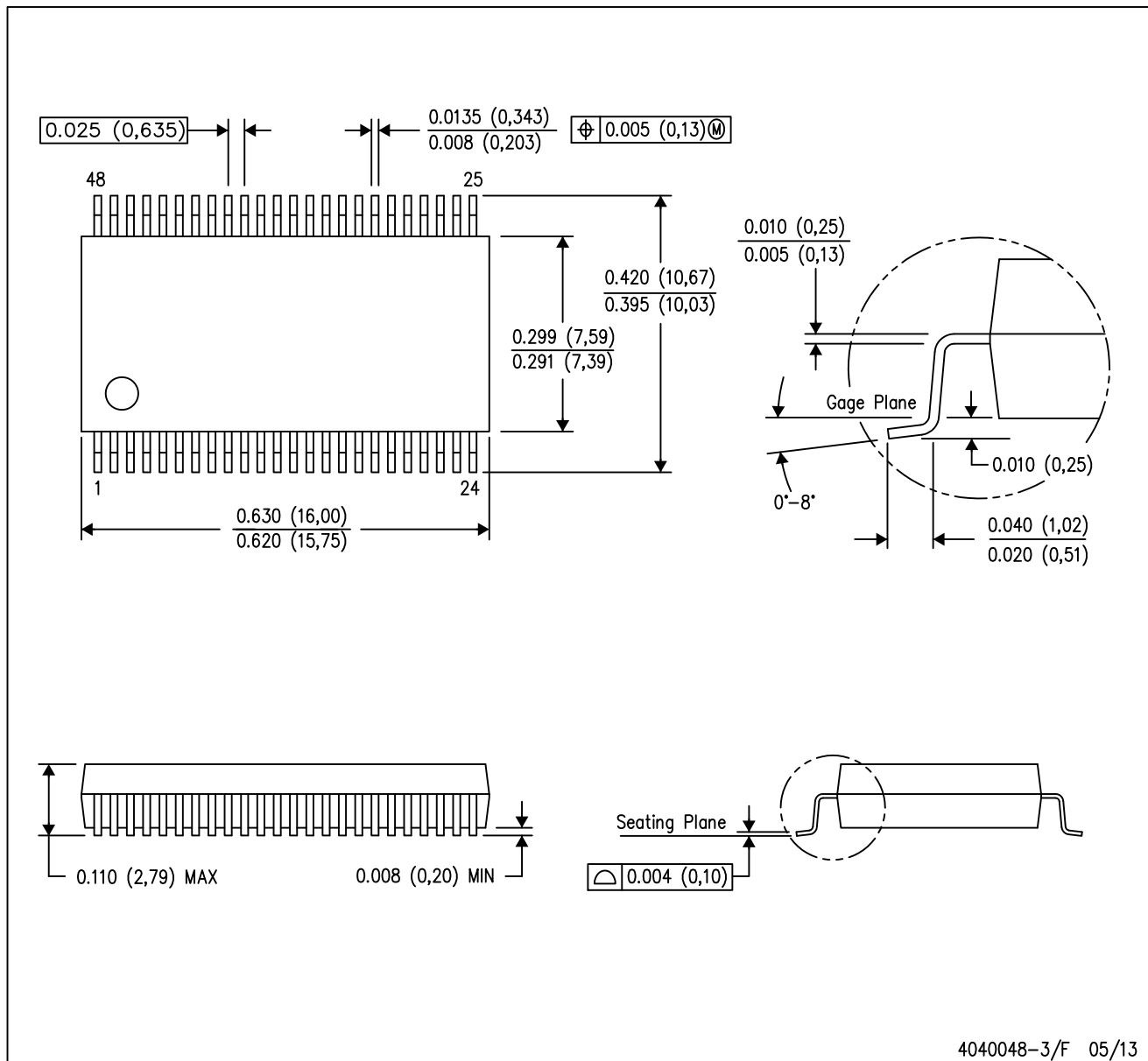
PLASTIC SMALL-OUTLINE PACKAGE



- NOTES:
- A. All linear dimensions are in inches (millimeters).
  - B. This drawing is subject to change without notice.
  - C. Body dimensions do not include mold flash or protrusion not to exceed 0.006 (0,15).
  - D. Falls within JEDEC MO-118

PowerPAD is a trademark of Texas Instruments.

DGV (R-PDSO-G\*\*)

PLASTIC SMALL-OUTLINE

24 PINS SHOWN



- NOTES: A. All linear dimensions are in millimeters.  
 B. This drawing is subject to change without notice.  
 C. Body dimensions do not include mold flash or protrusion, not to exceed 0,15 per side.  
 D. Falls within JEDEC: 24/48 Pins – MO-153  
 14/16/20/56 Pins – MO-194

DGG0048A

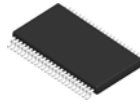

# PACKAGE OUTLINE

## TSSOP - 1.2 mm max height

SMALL OUTLINE PACKAGE

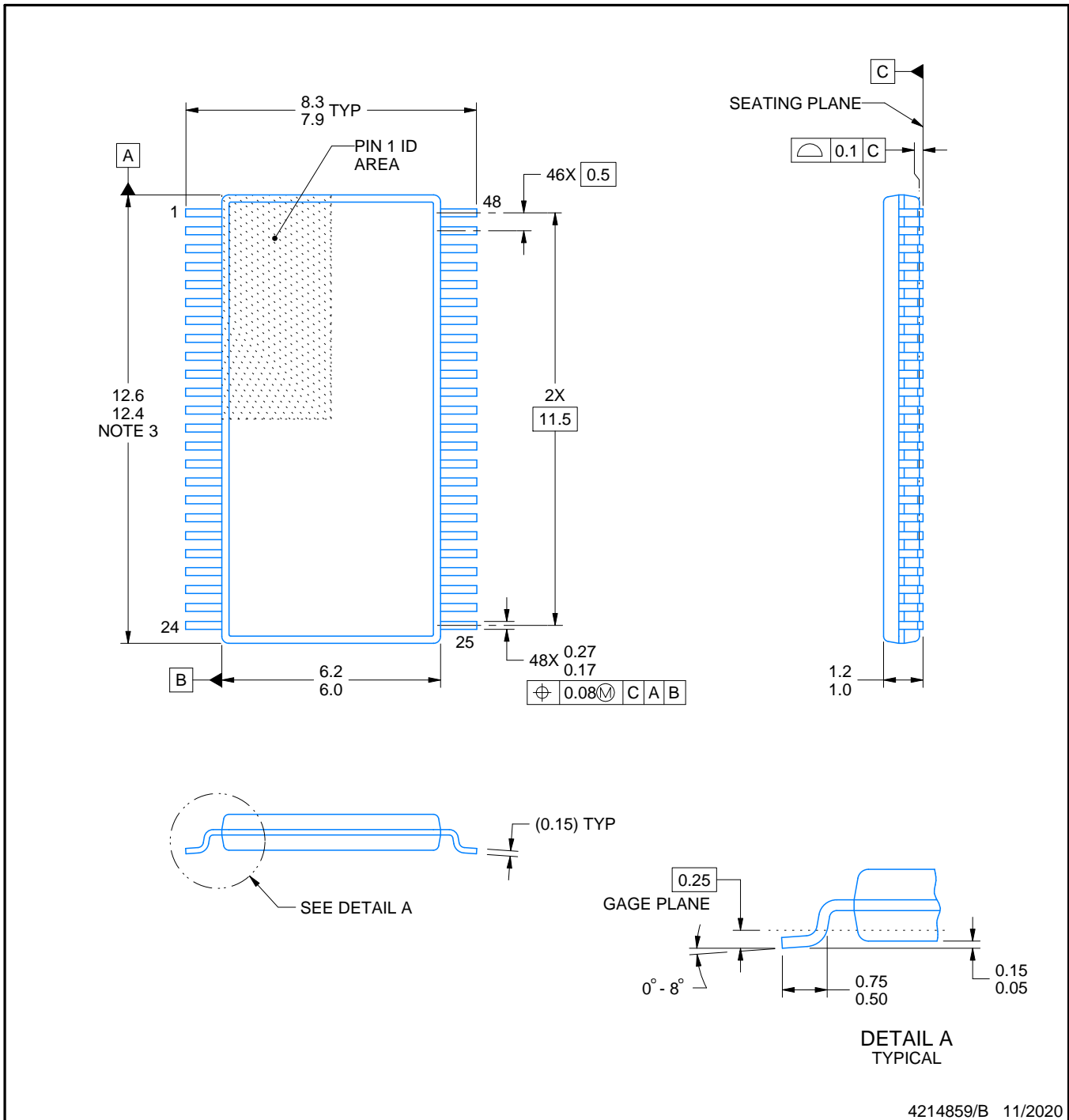

4214859/B 11/2020

### NOTES:

- All linear dimensions are in millimeters. Any dimensions in parenthesis are for reference only. Dimensioning and tolerancing per ASME Y14.5M.
- This drawing is subject to change without notice.
- This dimension does not include mold flash, protrusions, or gate burrs. Mold flash, protrusions, or gate burrs shall not exceed 0.15 mm per side.
- Reference JEDEC registration MO-153.

# EXAMPLE BOARD LAYOUT

DGG0048A

TSSOP - 1.2 mm max height

SMALL OUTLINE PACKAGE

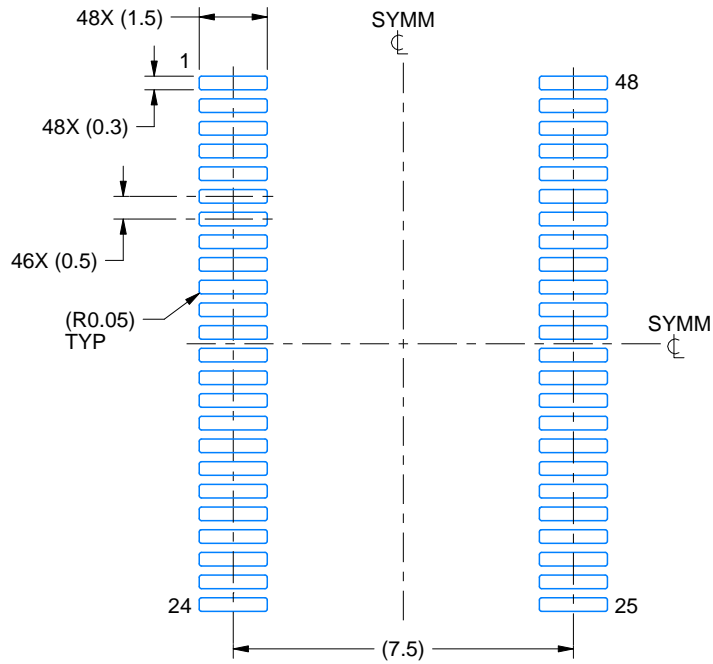

LAND PATTERN EXAMPLE  
SCALE:6X

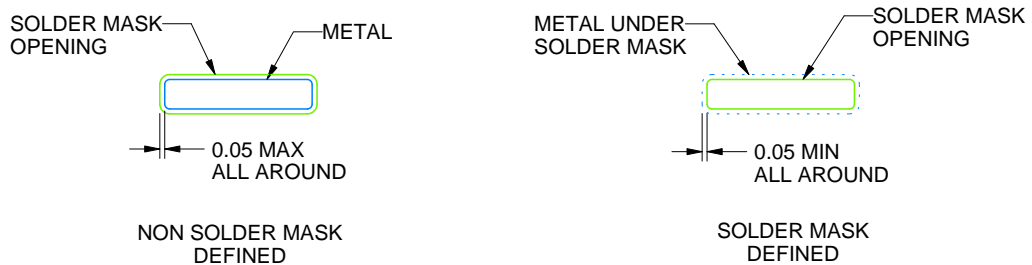

SOLDER MASK DETAILS

4214859/B 11/2020

NOTES: (continued)

5. Publication IPC-7351 may have alternate designs.
6. Solder mask tolerances between and around signal pads can vary based on board fabrication site.

# EXAMPLE STENCIL DESIGN

DGG0048A

TSSOP - 1.2 mm max height

SMALL OUTLINE PACKAGE

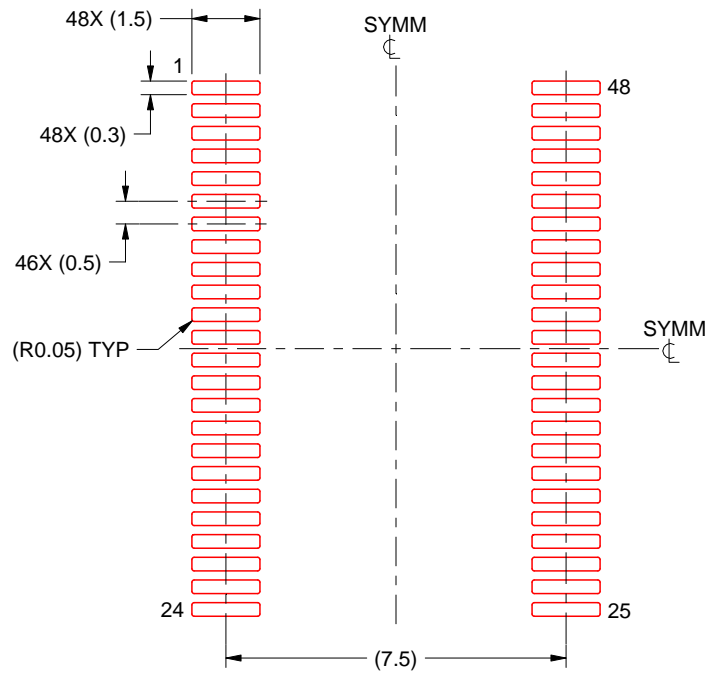

SOLDER PASTE EXAMPLE  
BASED ON 0.125 mm THICK STENCIL  
SCALE:6X

4214859/B 11/2020

NOTES: (continued)

7. Laser cutting apertures with trapezoidal walls and rounded corners may offer better paste release. IPC-7525 may have alternate design recommendations.
8. Board assembly site may have different recommendations for stencil design.

DGG (R-PDSO-G\*\*)

PLASTIC SMALL-OUTLINE PACKAGE

48 PINS SHOWN

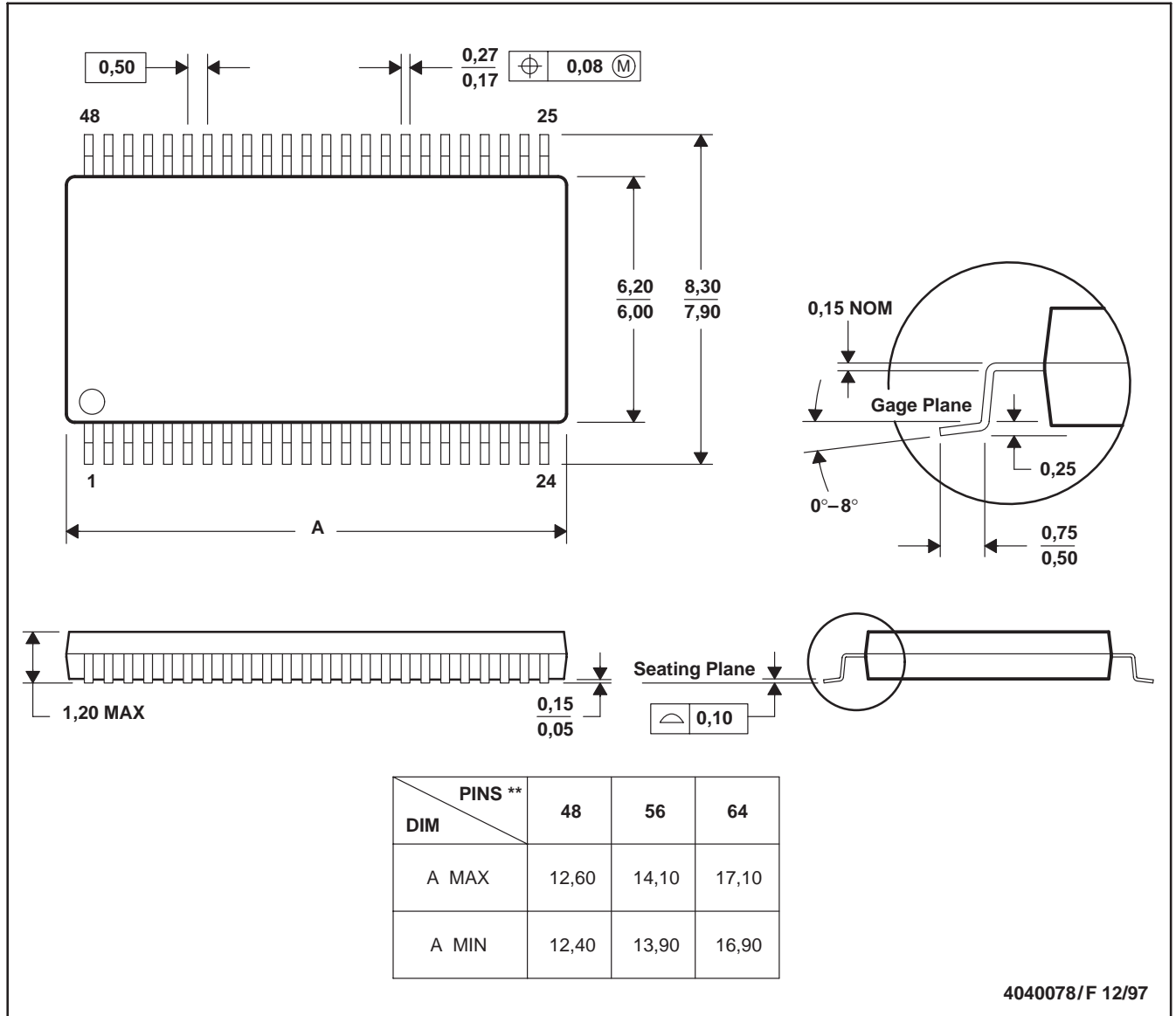

- NOTES: A. All linear dimensions are in millimeters.  
 B. This drawing is subject to change without notice.  
 C. Body dimensions do not include mold protrusion not to exceed 0,15.  
 D. Falls within JEDEC MO-153

## IMPORTANT NOTICE AND DISCLAIMER

TI PROVIDES TECHNICAL AND RELIABILITY DATA (INCLUDING DATA SHEETS), DESIGN RESOURCES (INCLUDING REFERENCE DESIGNS), APPLICATION OR OTHER DESIGN ADVICE, WEB TOOLS, SAFETY INFORMATION, AND OTHER RESOURCES "AS IS" AND WITH ALL FAULTS, AND DISCLAIMS ALL WARRANTIES, EXPRESS AND IMPLIED, INCLUDING WITHOUT LIMITATION ANY IMPLIED WARRANTIES OF MERCHANTABILITY, FITNESS FOR A PARTICULAR PURPOSE OR NON-INFRINGEMENT OF THIRD PARTY INTELLECTUAL PROPERTY RIGHTS.

These resources are intended for skilled developers designing with TI products. You are solely responsible for (1) selecting the appropriate TI products for your application, (2) designing, validating and testing your application, and (3) ensuring your application meets applicable standards, and any other safety, security, regulatory or other requirements.

These resources are subject to change without notice. TI grants you permission to use these resources only for development of an application that uses the TI products described in the resource. Other reproduction and display of these resources is prohibited. No license is granted to any other TI intellectual property right or to any third party intellectual property right. TI disclaims responsibility for, and you will fully indemnify TI and its representatives against, any claims, damages, costs, losses, and liabilities arising out of your use of these resources.

TI's products are provided subject to [TI's Terms of Sale](#) or other applicable terms available either on [ti.com](http://ti.com) or provided in conjunction with such TI products. TI's provision of these resources does not expand or otherwise alter TI's applicable warranties or warranty disclaimers for TI products.

TI objects to and rejects any additional or different terms you may have proposed.

Mailing Address: Texas Instruments, Post Office Box 655303, Dallas, Texas 75265  
Copyright © 2022, Texas Instruments Incorporated

## Looking for pricing, stock, or lifecycle information?

Click below to explore more details on WIN SOURCE:

 [View SN74LVC16T245DLR on WIN SOURCE](#)

 [Texas Instruments](#) Information

## Optimize Your Supply Chain with WIN SOURCE Solutions

-  Global Sourcing Solution
-  Obsolete Management
-  Cost Control Management
-  Shortage Management
-  Alternative Solution
-  Excess Inventory Management