



**THE DATASHEET OF
SN74LV595APWR**



SN74LV595A 8-Bit Shift Registers With 3-State Output Registers

1 Features

- 2-V to 5.5-V V_{CC} Operation
- Max t_{pd} of 7.1 ns at 5 V
- Typical V_{OLP} (Output Ground Bounce) < 0.8 V at $V_{CC} = 3.3$ V, $T_A = 25^\circ\text{C}$
- Typical V_{OHV} (Output V_{OH} Undershoot) > 2.3 V at $V_{CC} = 3.3$ V, $T_A = 25^\circ\text{C}$
- Support Mixed-Mode Voltage Operation on All Ports
- 8-Bit Serial-In, Parallel-Out Shift
- I_{off} Supports Live Insertion, Partial Power-Down Mode, and Back-Drive Protection
- Shift Register Has Direct Clear
- Latch-Up Performance Exceeds 250 mA Per JESD 17
- ESD Protection Exceeds JESD 22
 - 2000-V Human-Body Model
 - 200-V Machine Model
 - 1000-V Charged-Device Model

2 Applications

- Network Switches
- Power Infrastructures
- PCs and Notebooks
- LED Displays
- Servers
- I/O Expanders

3 Description

The SN74LV595A device contains an 8-bit serial-in, parallel-out shift register that feeds an 8-bit D-type storage register. Both the shift register clock (SRCLK) and storage register clock (RCLK) are positive-edge triggered.

Device Information

PART NUMBER	PACKAGE	BODY SIZE (NOM)
SNx4LV595A	VQFN (16)	4.00 mm x 3.50 mm
	TSSOP (16)	5.00 mm x 4.40 mm
	SOP (16)	10.20 mm x 5.30 mm
	SOIC (16)	9.00 mm x 3.90 mm

(1) For all available packages, see the orderable addendum at the end of the data sheet.

Simplified Schematic

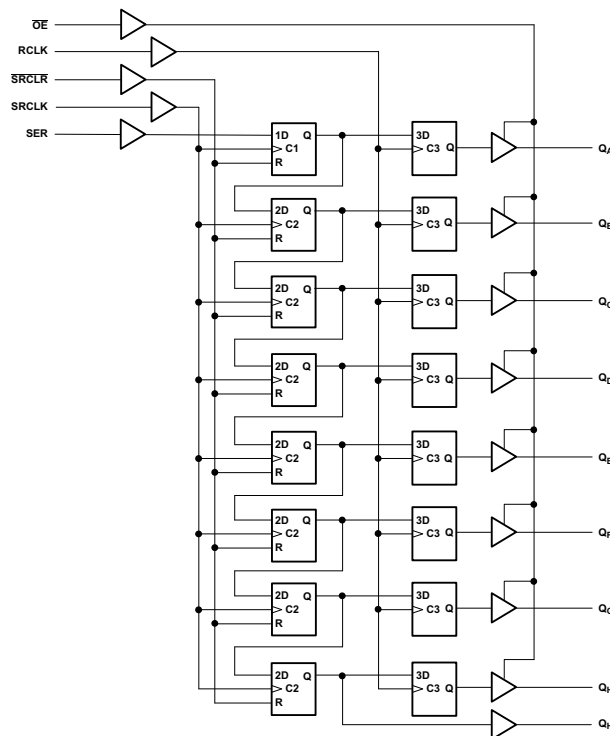

Copyright © 2016, Texas Instruments Incorporated



Table of Contents

1 Features	1	7 Parameter Measurement Information	12
2 Applications	1	8 Detailed Description	13
3 Description	1	8.1 Overview	13
4 Revision History	2	8.2 Functional Block Diagram	13
5 Pin Configuration and Functions	3	8.3 Feature Description	14
6 Specifications	4	8.4 Device Functional Modes	14
6.1 Absolute Maximum Ratings	4	9 Application and Implementation	15
6.2 ESD Ratings	4	9.1 Application Information	15
6.3 Recommended Operating Conditions	5	9.2 Typical Application	15
6.4 Thermal Information	5	10 Power Supply Recommendations	16
6.5 Electrical Characteristics	6	11 Layout	16
6.6 Timing Requirements, $V_{CC} = 2.5\text{ V} \pm 0.2\text{ V}$	6	11.1 Layout Guidelines	16
6.7 Timing Requirements, $V_{CC} = 3.3\text{ V} \pm 0.3\text{ V}$	7	11.2 Layout Example	16
6.8 Timing Requirements, $V_{CC} = 5\text{ V} \pm 0.5\text{ V}$	7	12 Device and Documentation Support	17
6.9 Switching Characteristics, $V_{CC} = 2.5\text{ V} \pm 0.2\text{ V}$	9	12.1 Community Resources	17
6.10 Switching Characteristics, $V_{CC} = 3.3\text{ V} \pm 0.3\text{ V}$	9	12.2 Trademarks	17
6.11 Switching Characteristics, $V_{CC} = 5\text{ V} \pm 0.5\text{ V}$	10	12.3 Electrostatic Discharge Caution	17
6.12 Noise Characteristics	10	12.4 Glossary	17
6.13 Operating Characteristics	10	13 Mechanical, Packaging, and Orderable Information	17
6.14 Typical Characteristics	11		

4 Revision History

Changes from Revision P (October 2014) to Revision Q	Page
• Changed "Handling Ratings" to "ESD Ratings"	2
• Changed "I" to "O" on Q_A row in <i>Pin Functions</i> table	3
• Changed " Q_A Inout" to " Q_A Output" in <i>Pin Functions</i> table	3
• Changed "Handling Ratings" to "ESD Ratings"	4

Changes from Revision O (January 2011) to Revision P	Page
• Updated document to new TI data sheet format	1
• Deleted Ordering Information table	1
• Deleted SN54LV595A from data sheet	1
• Changed I_{off} bullet in Features	1
• Added Applications	1
• Added Pin Functions table	3
• Added Handling Ratings table	4
• Changed MAX operating temperature to 125°C in Recommended Operating Conditions table	5
• Added Thermal Information table	5
• Added -40°C to 125°C for SN74LV595A in Electrical Characteristics table	6
• Added -40°C to 125°C for SN74LV595A in all three Timing Requirements tables	6
• Added -40°C to 125°C for SN74LV595A in all three Switching Requirements tables	9
• Added Detailed Description section	13
• Added Application and Implementation section	15
• Added Power Supply Recommendations and Layout sections	16

5 Pin Configuration and Functions

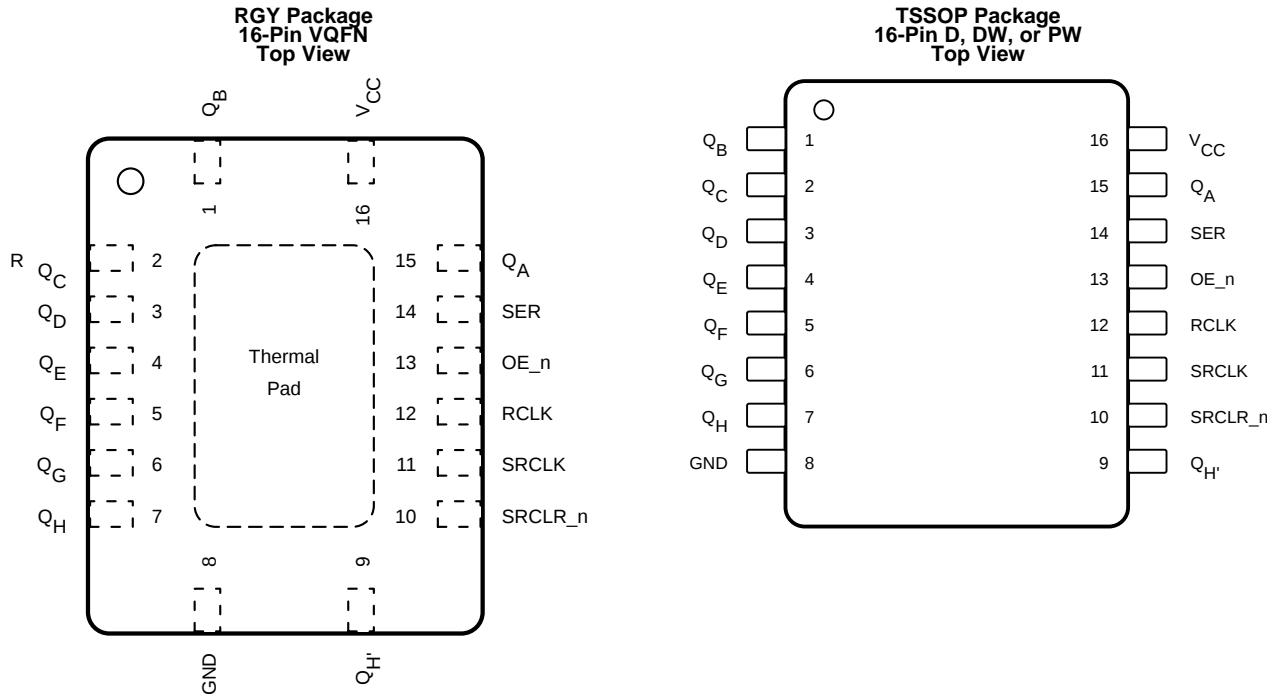

Pin Functions

PIN		I/O	DESCRIPTION
NAME	NO.		
GND	8	—	Ground Pin
OE_n	13	I	Output Enable Pin
Q _A	15	O	Q _A Output
Q _B	1	O	Q _B Output
Q _C	2	O	Q _C Output
Q _D	3	O	Q _D Output
Q _E	4	O	Q _E Output
Q _F	5	O	Q _F Output
Q _G	6	O	Q _G Output
Q _H	7	O	Q _H Output
Q _{H'}	9	O	Q _{H'} Output
RCLK	12	I	RCLK Input
SER	14	I	SER Input
SRCLK	11	I	SRCLK Input
SRCLR_n	10	I	SRCLR Input
V _{CC}	16	—	Power Pin

6 Specifications

6.1 Absolute Maximum Ratings

 over operating free-air temperature range (unless otherwise noted)⁽¹⁾

		MIN	MAX	UNIT
V _{CC}	Supply voltage range	-0.5	7	V
V _I	Input voltage range ⁽²⁾	-0.5	7	V
V _O	Voltage range applied to any output in the high-impedance or power-off state ⁽²⁾	-0.5	7	V
V _O	Output voltage range applied in the high or low state ⁽²⁾⁽³⁾	-0.5	V _{CC} + 0.5	V
I _{IK}	Input clamp current	V _I < 0		-20 mA
I _{OK}	Output clamp current	V _O < 0		-50 mA
I _O	Continuous output current	V _O = 0 to V _{CC}		±35 mA
	Continuous current through V _{CC} or GND			±70 mA

- (1) Stresses beyond those listed under *Absolute Maximum Ratings* may cause permanent damage to the device. These are stress ratings only, and functional operation of the device at these or any other conditions beyond those indicated under *Recommended Operating Conditions* is not implied. Exposure to absolute-maximum-rated conditions for extended periods may affect device reliability.
- (2) The input and output negative-voltage ratings may be exceeded if the input and output current ratings are observed.
- (3) This value is limited to 5.5-V maximum.

6.2 ESD Ratings

		MIN	MAX	UNIT
T _{stg}	Storage temperature range	-65	150	°C
V _(ESD)	Electrostatic discharge	Human body model (HBM), per ANSI/ESDA/JEDEC JS-001, all pins ⁽¹⁾		V
		Charged device model (CDM), per JEDEC specification JESD22-C101, all pins ⁽²⁾		
		0	2000	
		0	1000	

- (1) JEDEC document JEP155 states that 500-V HBM allows safe manufacturing with a standard ESD control process.
- (2) JEDEC document JEP157 states that 250-V CDM allows safe manufacturing with a standard ESD control process.

6.3 Recommended Operating Conditions

 over operating free-air temperature range (unless otherwise noted)⁽¹⁾

		SN74LV595A		UNIT	
		MIN	MAX		
V_{CC}	Supply voltage	2	5.5	V	
V_{IH}	High-level input voltage	$V_{CC} = 2\text{ V}$	1.5	V	
		$V_{CC} = 2.3\text{ V to }2.7\text{ V}$	$V_{CC} \times 0.7$		
		$V_{CC} = 3\text{ V to }3.6\text{ V}$	$V_{CC} \times 0.7$		
		$V_{CC} = 4.5\text{ V to }5.5\text{ V}$	$V_{CC} \times 0.7$		
V_{IL}	Low-level input voltage	$V_{CC} = 2\text{ V}$	0.5	V	
		$V_{CC} = 2.3\text{ V to }2.7\text{ V}$	$V_{CC} \times 0.3$		
		$V_{CC} = 3\text{ V to }3.6\text{ V}$	$V_{CC} \times 0.3$		
		$V_{CC} = 4.5\text{ V to }5.5\text{ V}$	$V_{CC} \times 0.3$		
V_I	Input voltage	0	5.5	V	
V_O	Output voltage	High or low state	0	V_{CC}	V
		3-state	0	5.5	
I_{OH}	High-level output current	$V_{CC} = 2\text{ V}$		-50	μA
		$V_{CC} = 2.3\text{ V to }2.7\text{ V}$		-2	mA
		$V_{CC} = 3\text{ V to }3.6\text{ V}$		-8	
		$V_{CC} = 4.5\text{ V to }5.5\text{ V}$		-16	
I_{OL}	Low-level output current	$V_{CC} = 2\text{ V}$		50	μA
		$V_{CC} = 2.3\text{ V to }2.7\text{ V}$		2	mA
		$V_{CC} = 3\text{ V to }3.6\text{ V}$		8	
		$V_{CC} = 4.5\text{ V to }5.5\text{ V}$		16	
$\Delta t/\Delta v$	Input transition rise or fall rate	$V_{CC} = 2.3\text{ V to }2.7\text{ V}$		200	ns/V
		$V_{CC} = 3\text{ V to }3.6\text{ V}$		100	
		$V_{CC} = 4.5\text{ V to }5.5\text{ V}$		20	
T_A	Operating free-air temperature	-40	125	$^{\circ}\text{C}$	

(1) All unused inputs of the device must be held at V_{CC} or GND to ensure proper device operation. Refer to the TI application report, *Implications of Slow or Floating CMOS Inputs (SCBA004)*.

6.4 Thermal Information

THERMAL METRIC ⁽¹⁾	SN74LV595A					UNIT	
	D	DB	NS	PW	RGY		
	16 PINS	16 PINS	16 PINS	16 PINS	16 PINS		
$R_{\theta JA}$	Junction-to-ambient thermal resistance	80.2	97.8	79.4	106.1	39.5	$^{\circ}\text{C/W}$
$R_{\theta JC(top)}$	Junction-to-case (top) thermal resistance	40.3	48.1	35.8	40.8	50.5	
$R_{\theta JB}$	Junction-to-board thermal resistance	38.0	48.5	40.2	51.1	17.1	
Ψ_{JT}	Junction-to-top characterization parameter	9.0	10.0	5.5	3.8	0.9	
Ψ_{JB}	Junction-to-board characterization parameter	37.7	47.9	39.9	50.6	17.2	
$R_{\theta JC(bot)}$	Junction-to-case (bottom) thermal resistance	—	—	—	—	5.9	

(1) For more information about traditional and new thermal metrics, see the *IC Package Thermal Metrics* application report ([SPRA953](#)).

6.5 Electrical Characteristics

over recommended operating free-air temperature range (unless otherwise noted)

PARAMETER	TEST CONDITIONS	V _{CC}	–40°C to 85°C SN74LV595A			–40°C to 125°C SN74LV595A			UNIT
			MIN	TYP	MAX	MIN	TYP	MAX	
V _{OH}	I _{OH} = –50 μA	2 V to 5.5 V	V _{CC} – 0.1			V _{CC} – 0.1			V
		I _{OH} = –2 mA	2.3 V	2			2		
	Q _{H'}	3 V	I _{OH} = –6 mA			2.48			
	Q _A –Q _H		I _{OH} = –8 mA			2.48			
	Q _{H'}	4.5 V	I _{OH} = –12 mA			3.8			
	Q _A –Q _H		I _{OH} = –16 mA			3.8			
V _{OL}	I _{OL} = 50 μA	2 V to 5.5 V				0.1			V
		I _{OL} = 2 mA	2.3 V				0.4		
	Q _{H'}	3 V	I _{OL} = 6 mA			0.44			
	Q _A –Q _H		I _{OL} = 8 mA			0.44			
	Q _{H'}	4.5 V	I _{OL} = 12 mA			0.55			
	Q _A –Q _H		I _{OL} = 16 mA			0.55			
I _I	V _I = 5.5 V or GND	0 to 5.5 V				±1			μA
I _{OZ}	V _O = V _{CC} or GND, Q _A – Q _H	5.5 V				±5			μA
I _{CC}	V _I = V _{CC} or GND, I _O = 0	5.5 V				20			μA
I _{off}	V _I or V _O = 0 to 5.5 V	0				5			μA
C _i	V _I = V _{CC} or GND	3.3 V	3.5			3.5			pF

6.6 Timing Requirements, V_{CC} = 2.5 V ± 0.2 V

 over recommended operating free-air temperature range (unless otherwise noted) (see [Figure 3](#))

		T _A = 25°C		–40°C to 85°C SN74LV595A		–40°C to 125°C SN74LV595A		UNIT
		MIN	MAX	MIN	MAX	MIN	MAX	
t _w	Pulse duration	SRCLK high or low	7		7.5		8.5	ns
		RCLK high or low	7		7.5		8.5	
		$\overline{\text{SRCLR}}$ low	6		6.5		7.5	
t _{su}	Setup time	SER before SRCLK↑	5.5		5.5		6.5	ns
		SRCLK↑ before RCLK↑ ⁽¹⁾	8		9		10	
		$\overline{\text{SRCLR}}$ low before RCLK↑	8.5		9.5		10.5	
		$\overline{\text{SRCLR}}$ high (inactive) before SRCLK↑	4		4		5	
t _h	Hold time	SER after SRCLK↑	1.5		1.5		2.5	ns

- (1) This setup time allows the storage register to receive stable data from the shift register. The clocks can be tied together, in which case the shift register is one clock pulse ahead of the storage register.

6.7 Timing Requirements, $V_{CC} = 3.3\text{ V} \pm 0.3\text{ V}$

 over recommended operating free-air temperature range (unless otherwise noted) (see [Figure 3](#))

		$T_A = 25^\circ\text{C}$		$-40^\circ\text{C to } 85^\circ\text{C}$ SN74LV595A		$-40^\circ\text{C to } 125^\circ\text{C}$ SN74LV595A		UNIT
		MIN	MAX	MIN	MAX	MIN	MAX	
t_w	Pulse duration	SRCLK high or low	5.5		5.5		6.5	ns
		RCLK high or low	5.5		5.5		6.5	
		$\overline{\text{SRCLR}}$ low	5		5		6	
t_{su}	Setup time	SER before SRCLK \uparrow	3.5		3.5		4.5	ns
		SRCLK \uparrow before RCLK \uparrow ⁽¹⁾	8		8.5		9.5	
		$\overline{\text{SRCLR}}$ low before RCLK \uparrow	8		9		10	
		$\overline{\text{SRCLR}}$ high (inactive) before SRCLK \uparrow	3		3		4	
t_h	Hold time	SER after SRCLK \uparrow	1.5		1.5		2.5	ns

(1) This setup time allows the storage register to receive stable data from the shift register. The clocks can be tied together, in which case the shift register is one clock pulse ahead of the storage register.

6.8 Timing Requirements, $V_{CC} = 5\text{ V} \pm 0.5\text{ V}$

 over recommended operating free-air temperature range (unless otherwise noted) (see [Figure 3](#))

		$T_A = 25^\circ\text{C}$		$-40^\circ\text{C to } 85^\circ\text{C}$ SN74LV595A		$-40^\circ\text{C to } 125^\circ\text{C}$ SN74LV595A		UNIT
		MIN	MAX	MIN	MAX	MIN	MAX	
t_w	Pulse duration	SRCLK high or low	5		5		6	ns
		RCLK high or low	5		5		6	
		$\overline{\text{SRCLR}}$ low	5.2		5.2		6.2	
t_{su}	Setup time	SER before SRCLK \uparrow	3		3		4	ns
		SRCLK \uparrow before RCLK \uparrow ⁽¹⁾	5		5		6	
		$\overline{\text{SRCLR}}$ low before RCLK \uparrow	5		5		6	
		$\overline{\text{SRCLR}}$ high (inactive) before SRCLK \uparrow	2.5		2.5		3.5	
t_h	Hold time	SER after SRCLK \uparrow	2		2		3	ns

(1) This setup time allows the storage register to receive stable data from the shift register. The clocks can be tied together, in which case the shift register is one clock pulse ahead of the storage register.

SN74LV595A

SCLS414Q –APRIL 1998–REVISED APRIL 2016

www.ti.com

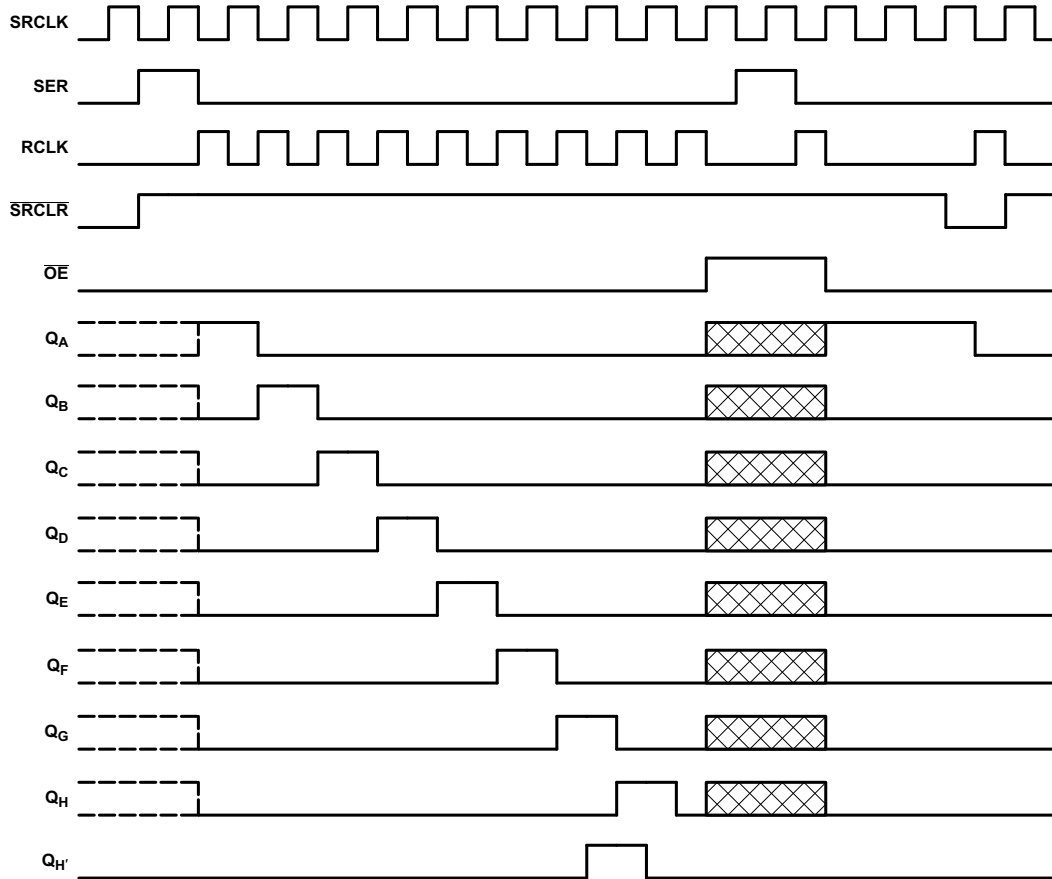

NOTE:  implies that the output is in 3-State mode.

Copyright © 2016, Texas Instruments Incorporated

Figure 1. Timing Diagram

6.9 Switching Characteristics, $V_{CC} = 2.5 V \pm 0.2 V$

over recommended operating free-air temperature range (unless otherwise noted) (see Figure 3)

PARAMETER	FROM (INPUT)	TO (OUTPUT)	LOAD CAPACITANCE	$T_A = 25^\circ\text{C}$			$-40^\circ\text{C to } 85^\circ\text{C}$ SN74LV595A		$-40^\circ\text{C to } 125^\circ\text{C}$ SN74LV595A		UNIT
				MIN	TYP	MAX	MIN	MAX	MIN	MAX	
f_{\max}			$C_L = 15 \text{ pF}$	65 ⁽¹⁾	80 ⁽¹⁾		45		45		MHz
			$C_L = 50 \text{ pF}$	60	70		40		40		
t_{PLH}	RCLK	$Q_A - Q_H$	$C_L = 15 \text{ pF}$		8.4 ⁽¹⁾	14.2 ⁽¹⁾	1	15.8	1	16.8	ns
t_{PHL}					8.4 ⁽¹⁾	14.2 ⁽¹⁾	1	15.8	1	16.8	
t_{PLH}	SRCLK	$Q_{H'}$			9.4 ⁽¹⁾	19.6 ⁽¹⁾	1	22.2	1	23.2	
t_{PHL}					9.4 ⁽¹⁾	19.6 ⁽¹⁾	1	22.2	1	23.2	
t_{PHL}	$\overline{\text{SRCLR}}$	$Q_{H'}$			8.7 ⁽¹⁾	14.6 ⁽¹⁾	1	16.3	1	17.3	
t_{PZH}				$\overline{\text{OE}}$	$Q_A - Q_H$		8.2 ⁽¹⁾	13.9 ⁽¹⁾	1	15	
t_{PZL}						10.9 ⁽¹⁾	18.1 ⁽¹⁾	1	20.3	1	
t_{PHZ}	$\overline{\text{OE}}$	$Q_A - Q_H$			8.3 ⁽¹⁾	13.7 ⁽¹⁾	1	15.6	1	16.6	
t_{PLZ}						9.2 ⁽¹⁾	15.2 ⁽¹⁾	1	16.7	1	
t_{PLH}	RCLK	$Q_A - Q_H$		$C_L = 50 \text{ pF}$		11.2	17.2	1	19.3	1	
t_{PHL}						11.2	17.2	1	19.3	1	21.3
t_{PLH}	SRCLK	$Q_{H'}$			13.1	22.5	1	25.5	1	27.5	
t_{PHL}						13.1	22.5	1	25.5	1	27.5
t_{PHL}	$\overline{\text{SRCLR}}$	$Q_{H'}$			12.4	18.8	1	21.1	1	23.1	
t_{PZH}			$\overline{\text{OE}}$		$Q_A - Q_H$		10.8	17	1	18.3	1
t_{PZL}						13.4	21	1	23	1	25
t_{PHZ}	$\overline{\text{OE}}$	$Q_A - Q_H$			12.2	18.3	1	19.5	1	21.5	
t_{PLZ}						14	20.9	1	22.6	1	24.6

(1) On products compliant to MIL-PRF-38535, this parameter is not production tested.

6.10 Switching Characteristics, $V_{CC} = 3.3 V \pm 0.3 V$

over recommended operating free-air temperature range (unless otherwise noted) (see Figure 3)

PARAMETER	FROM (INPUT)	TO (OUTPUT)	LOAD CAPACITANCE	$T_A = 25^\circ\text{C}$			$-40^\circ\text{C to } 85^\circ\text{C}$ SN74LV595A		$-40^\circ\text{C to } 125^\circ\text{C}$ SN74LV595A		UNIT
				MIN	TYP	MAX	MIN	MAX	MIN	MAX	
f_{\max}			$C_L = 15 \text{ pF}$	80 ⁽¹⁾	120 ⁽¹⁾		70		70		MHz
			$C_L = 50 \text{ pF}$	55	105		50		50		
t_{PLH}	RCLK	$Q_A - Q_H$	$C_L = 15 \text{ pF}$		6 ⁽¹⁾	11.9 ⁽¹⁾	1	13.5	1	14.5	ns
t_{PHL}						6 ⁽¹⁾	11.9 ⁽¹⁾	1	13.5	1	
t_{PLH}	SRCLK	$Q_{H'}$			6.6 ⁽¹⁾	13 ⁽¹⁾	1	15	1	16	
t_{PHL}						6.6 ⁽¹⁾	13 ⁽¹⁾	1	15	1	
t_{PHL}	$\overline{\text{SRCLR}}$	$Q_{H'}$			6.2 ⁽¹⁾	12.8 ⁽¹⁾	1	13.7	1	14.7	
t_{PZH}				$\overline{\text{OE}}$	$Q_A - Q_H$		6 ⁽¹⁾	11.5 ⁽¹⁾	1	13.5	
t_{PZL}						7.8 ⁽¹⁾	11.5 ⁽¹⁾	1	13.5	1	
t_{PHZ}	$\overline{\text{OE}}$	$Q_A - Q_H$			6.1 ⁽¹⁾	14.7 ⁽¹⁾	1	15.2	1	16.2	
t_{PLZ}						6.3 ⁽¹⁾	14.7 ⁽¹⁾	1	15.2	1	
t_{PLH}	RCLK	$Q_A - Q_H$		$C_L = 50 \text{ pF}$		7.9	15.4	1	17	1	
t_{PHL}						7.9	15.4	1	17	1	19
t_{PLH}	SRCLK	$Q_{H'}$			9.2	16.5	1	18.5	1	20.5	
t_{PHL}						9.2	16.5	1	18.5	1	20.5
t_{PHL}	$\overline{\text{SRCLR}}$	$Q_{H'}$			9	16.3	1	17.2	1	19.2	
t_{PZH}			$\overline{\text{OE}}$		$Q_A - Q_H$		7.8	15	1	17	1
t_{PZL}						9.6	15	1	17	1	19
t_{PHZ}	$\overline{\text{OE}}$	$Q_A - Q_H$			8.1	15.7	1	16.2	1	18.2	
t_{PLZ}						9.3	15.7	1	16.2	1	18.2

(1) On products compliant to MIL-PRF-38535, this parameter is not production tested.

6.11 Switching Characteristics, $V_{CC} = 5\text{ V} \pm 0.5\text{ V}$

over recommended operating free-air temperature range (unless otherwise noted) (see Figure 3)

PARAMETER	FROM (INPUT)	TO (OUTPUT)	LOAD CAPACITANCE	$T_A = 25^\circ\text{C}$			$-40^\circ\text{C to } 85^\circ\text{C}$ SN74LV595A		$-40^\circ\text{C to } 125^\circ\text{C}$ SN74LV595A		UNIT
				MIN	TYP	MAX	MIN	MAX	MIN	MAX	
f_{max}			$C_L = 15\text{ pF}$	135 ⁽¹⁾	170 ⁽¹⁾		115		115	MHz	
			$C_L = 50\text{ pF}$	120	140		95		95		
t_{PLH}	RCLK	Q_A-Q_H	$C_L = 15\text{ pF}$	4.3 ⁽¹⁾	7.4 ⁽¹⁾		1	8.5	1	9.5	ns
t_{PHL}				4.3 ⁽¹⁾	7.4 ⁽¹⁾		1	8.5	1	9.5	
t_{PLH}	SRCLK	Q_H		4.5 ⁽¹⁾	8.2 ⁽¹⁾		1	9.4	1	10.4	
t_{PHL}				4.5 ⁽¹⁾	8.2 ⁽¹⁾		1	9.4	1	10.4	
t_{PHL}	$\overline{\text{SRCLR}}$	Q_H		4.5 ⁽¹⁾	8 ⁽¹⁾		1	9.1	1	10.1	
t_{PZH}				$\overline{\text{OE}}$	Q_A-Q_H	4.3 ⁽¹⁾	8.6 ⁽¹⁾		1	10	
t_{PZL}	5.4 ⁽¹⁾	8.6 ⁽¹⁾					1	10	1	11	
t_{PHZ}	$\overline{\text{OE}}$	Q_A-Q_H		2.4 ⁽¹⁾	6 ⁽¹⁾		1	7.1	1	7.1	
t_{PLZ}				2.7 ⁽¹⁾	5.1 ⁽¹⁾		1	7.2	1	7.2	
t_{PLH}	RCLK	Q_A-Q_H		$C_L = 50\text{ pF}$	5.6	9.4		1	10.5	1	
t_{PHL}			5.6		9.4		1	10.5	1	12.5	
t_{PLH}	SRCLK	Q_H	6.4		10.2		1	11.4	1	13.4	
t_{PHL}			6.4		10.2		1	11.4	1	13.4	
t_{PHL}	$\overline{\text{SRCLR}}$	Q_H	6.4		10		1	11.1	1	13.1	
t_{PZH}			$\overline{\text{OE}}$		Q_A-Q_H	5.7	10.6		1	12	1
t_{PZL}	6.8	10.6					1	12	1	14	
t_{PHZ}	$\overline{\text{OE}}$	Q_A-Q_H	3.5		10.3		1	11	1	13	
t_{PLZ}			3.4		10.3		1	11	1	13	

(1) On products compliant to MIL-PRF-38535, this parameter is not production tested.

6.12 Noise Characteristics

 $V_{CC} = 3.3\text{ V}$, $C_L = 50\text{ pF}$, $T_A = 25^\circ\text{C}$ ⁽¹⁾

PARAMETER		SN74LV595A			UNIT
		MIN	TYP	MAX	
$V_{OL(P)}$	Quiet output, maximum dynamic V_{OL}		0.3		V
$V_{OL(V)}$	Quiet output, minimum dynamic V_{OL}		-0.2		V
$V_{OH(V)}$	Quiet output, minimum dynamic V_{OH}		2.8		V
$V_{IH(D)}$	High-level dynamic input voltage	2.31			V
$V_{IL(D)}$	Low-level dynamic input voltage			0.99	V

(1) Characteristics are for surface-mount packages only.

6.13 Operating Characteristics

 $T_A = 25^\circ\text{C}$

PARAMETER	TEST CONDITIONS	V_{CC}	TYP	UNIT	
C_{pd}	Power dissipation capacitance	$C_L = 50\text{ pF}$, $f = 10\text{ MHz}$	3.3 V	111	pF
			5 V	114	

6.14 Typical Characteristics

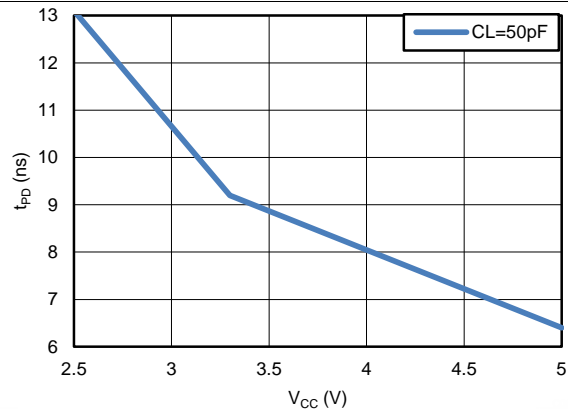
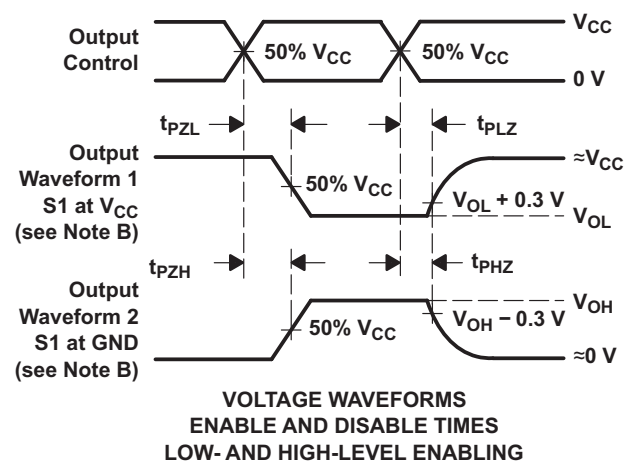
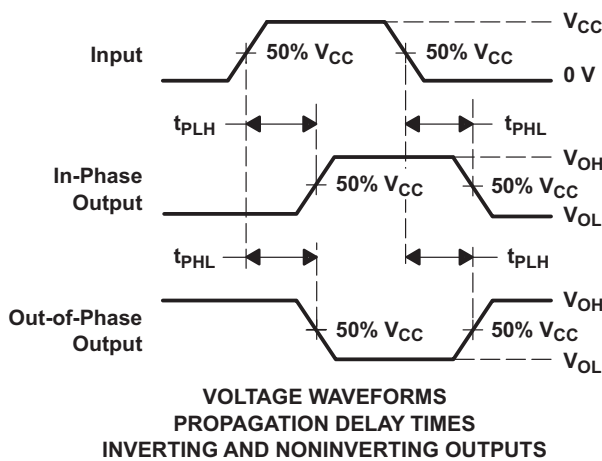
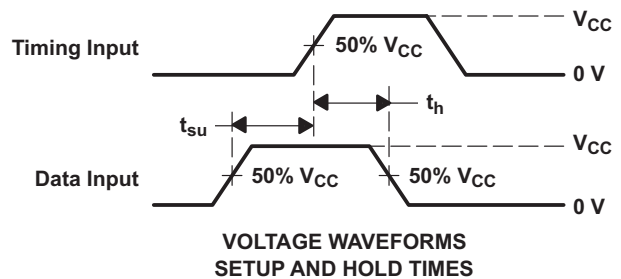
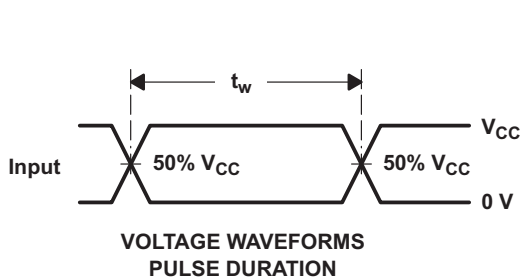
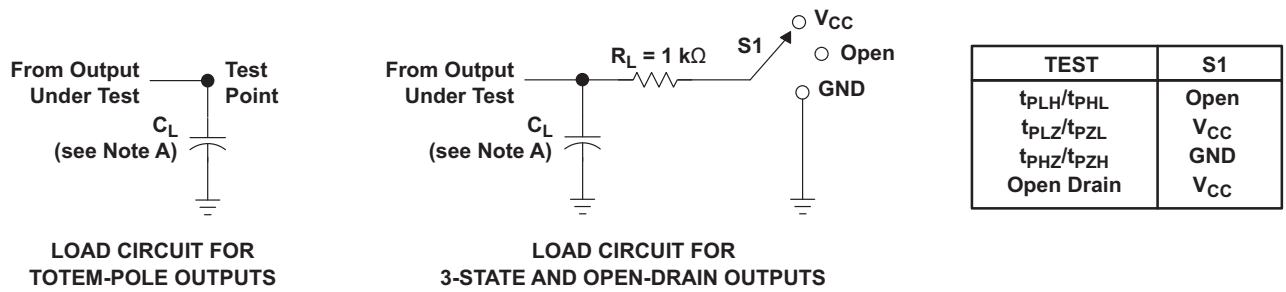

Figure 2. TPD vs V_{CC}

7 Parameter Measurement Information



- A. C_L includes probe and jig capacitance.
- B. Waveform 1 is for an output with internal conditions such that the output is low, except when disabled by the output control.
Waveform 2 is for an output with internal conditions such that the output is high, except when disabled by the output control.
- C. All input pulses are supplied by generators having the following characteristics: $PRR \leq 1\text{ MHz}$, $Z_O = 50\ \Omega$, $t_r \leq 3\text{ ns}$, $t_f \leq 3\text{ ns}$.
- D. The outputs are measured one at a time, with one input transition per measurement.
- E. t_{PLZ} and t_{PHZ} are the same as t_{dis} .
- F. t_{PZL} and t_{PZH} are the same as t_{en} .
- G. t_{PHL} and t_{PLH} are the same as t_{pd} .
- H. All parameters and waveforms are not applicable to all devices.

Figure 3. Load Circuit and Voltage Waveforms

8 Detailed Description

8.1 Overview

The SN74LV595A device contains an 8-bit serial-in, parallel-out shift register that feeds an 8-bit D-type storage register. The storage register has parallel 3-state outputs. Separate clocks are provided for the shift and storage registers. The shift register has a direct overriding clear (SRCLR) input, serial (SER) input, and serial outputs for cascading. When the output-enable (\overline{OE}) input is high, the outputs are in the high-impedance state. Both the shift register clock (SRCLK) and storage register clock (RCLK) are positive-edge triggered. If both clocks are connected together, the shift register always is one clock pulse ahead of the storage register.

8.2 Functional Block Diagram

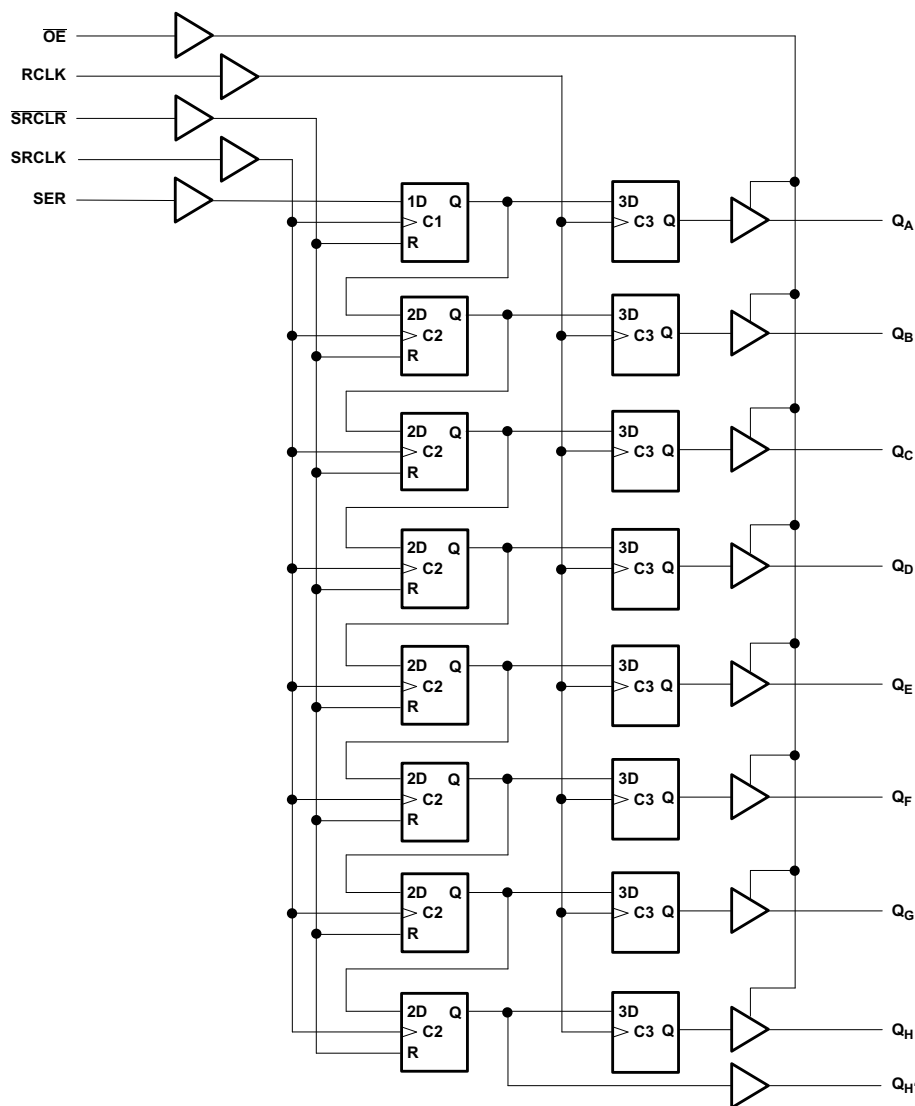

Copyright © 2016, Texas Instruments Incorporated

Figure 4. Logic Diagram (Positive Logic)

8.3 Feature Description

- Inputs are 5-V tolerant allowing for voltage translation down to V_{CC}
- Slow edges for reduced noise
- Low power
- I_{off} circuitry allows voltages on the inputs and outputs when $V_{CC} = 0$ V

8.4 Device Functional Modes

Table 1. Function Table

INPUTS					FUNCTION
SER	SRCLK	$\overline{\text{SRCLR}}$	RCLK	$\overline{\text{OE}}$	
X	X	X	X	H	Outputs Q_A – Q_H are disabled.
X	X	X	X	L	Outputs Q_A – Q_H are enabled.
X	X	L	X	X	Shift register is cleared.
L	↑	H	X	X	First stage of the shift register goes low. Other stages store the data of previous stage, respectively.
H	↑	H	X	X	First stage of the shift register goes high. Other stages store the data of previous stage, respectively.
X	X	X	↑	X	Shift-register data is stored in the storage register.

9 Application and Implementation

NOTE

Information in the following applications sections is not part of the TI component specification, and TI does not warrant its accuracy or completeness. TI's customers are responsible for determining suitability of components for their purposes. Customers should validate and test their design implementation to confirm system functionality.

9.1 Application Information

The SN74LV595A is a low-drive CMOS device that can be used for a multitude of bus interface type applications where output ringing is a concern. The low drive and slow edge rates will minimize overshoot and undershoot on the outputs. The inputs are 5-V tolerant allowing for down translation to V_{CC} .

9.2 Typical Application

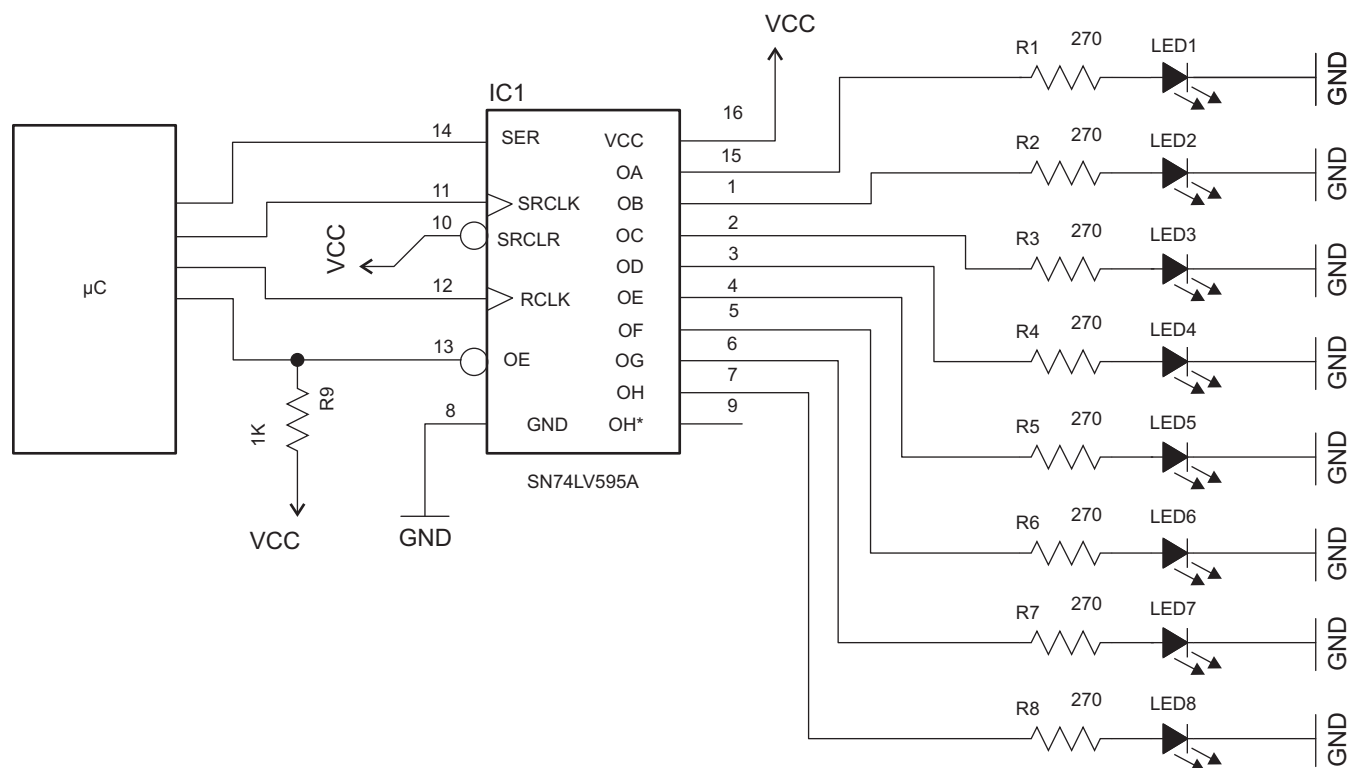

Copyright © 2016, Texas Instruments Incorporated

9.2.1 Design Requirements

This device uses CMOS technology and has balanced output drive. Care should be taken to avoid bus contention because it can drive currents that would exceed maximum limits. The high drive will also create fast edges into light loads so routing and load conditions should be considered to prevent ringing.

9.2.2 Detailed Design Procedure

1. Recommended Input Conditions:
 - For rise time and fall time specifications, see $\Delta t/\Delta V$ in the [Recommended Operating Conditions](#) table.
 - For specified high and low levels, see V_{IH} and V_{IL} in the [Recommended Operating Conditions](#) table.
 - Inputs are overvoltage tolerant allowing them to go as high as 5.5 V at any valid V_{CC} .
2. Recommend Output Conditions:
 - Load currents should not exceed 35 mA per output and 70 mA total for the part.

Typical Application (continued)

- Outputs should not be pulled above V_{CC} .

9.2.3 Application Curves

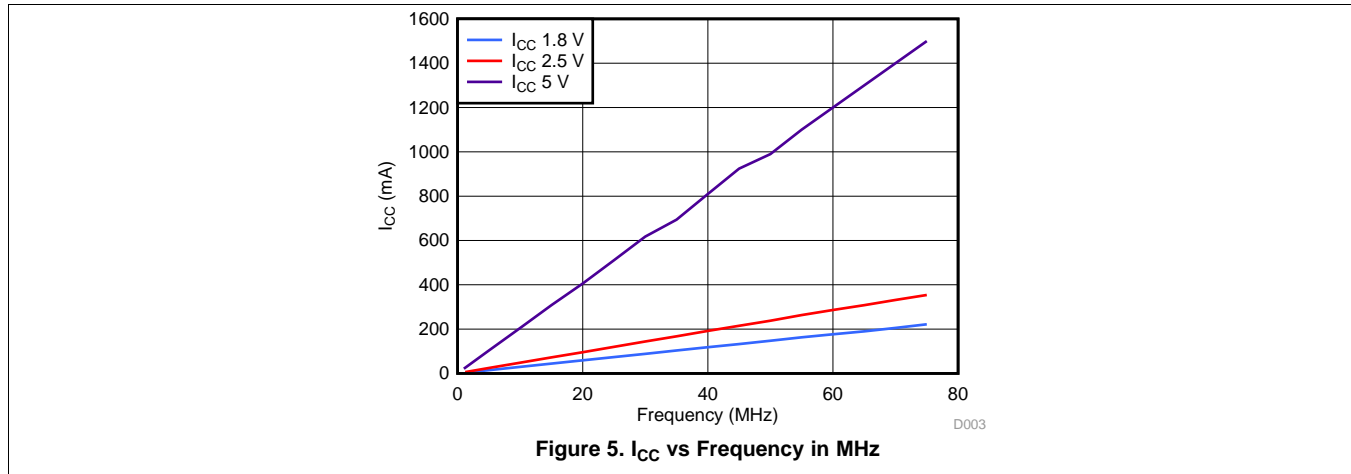

10 Power Supply Recommendations

The power supply can be any voltage between the MIN and MAX supply voltage rating located in the [Recommended Operating Conditions](#) table.

Each V_{CC} terminal should have a good bypass capacitor to prevent power disturbance. For devices with a single supply, a 0.1 μF capacitor is recommended. If there are multiple V_{CC} terminals then 0.01 μF or 0.022 μF capacitors are recommended for each power terminal. It is ok to parallel multiple bypass capacitors to reject different frequencies of noise. 0.1 μF and 1.0 μF capacitors are commonly used in parallel. The bypass capacitor should be installed as close to the power terminal as possible for the best results.

11 Layout

11.1 Layout Guidelines

When using multiple bit logic devices, inputs should not float. In many cases, functions or parts of functions of digital logic devices are unused. Some examples are when only two inputs of a triple-input AND gate are used, or when only 3 of the 4-buffer gates are used. Such input pins should not be left unconnected because the undefined voltages at the outside connections result in undefined operational states.

Specified in [Figure 6](#) are rules that must be observed under all circumstances. All unused inputs of digital logic devices must be connected to a high or low bias to prevent them from floating. The logic level that should be applied to any particular unused input depends on the function of the device. Generally they will be tied to GND or V_{CC} , whichever makes more sense or is more convenient. It is acceptable to float outputs unless the part is a transceiver. If the transceiver has an output enable pin, it will disable the outputs section of the part when asserted. This will not disable the input section of the I/Os so they also cannot float when disabled.

11.2 Layout Example

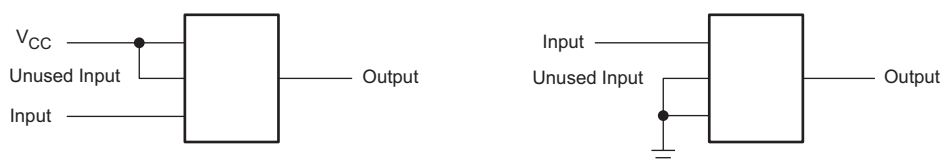

Figure 6. Layout Diagram

12 Device and Documentation Support

12.1 Community Resources

The following links connect to TI community resources. Linked contents are provided "AS IS" by the respective contributors. They do not constitute TI specifications and do not necessarily reflect TI's views; see TI's [Terms of Use](#).

TI E2E™ Online Community *TI's Engineer-to-Engineer (E2E) Community*. Created to foster collaboration among engineers. At e2e.ti.com, you can ask questions, share knowledge, explore ideas and help solve problems with fellow engineers.

Design Support *TI's Design Support* Quickly find helpful E2E forums along with design support tools and contact information for technical support.

12.2 Trademarks

E2E is a trademark of Texas Instruments.
All other trademarks are the property of their respective owners.

12.3 Electrostatic Discharge Caution



These devices have limited built-in ESD protection. The leads should be shorted together or the device placed in conductive foam during storage or handling to prevent electrostatic damage to the MOS gates.

12.4 Glossary

[SLYZ022](#) — *TI Glossary*.

This glossary lists and explains terms, acronyms, and definitions.

13 Mechanical, Packaging, and Orderable Information

The following pages include mechanical, packaging, and orderable information. This information is the most current data available for the designated devices. This data is subject to change without notice and revision of this document. For browser-based versions of this data sheet, refer to the left-hand navigation.

PACKAGING INFORMATION

Orderable Device	Status (1)	Package Type	Package Drawing	Pins	Package Qty	Eco Plan (2)	Lead/Ball Finish (6)	MSL Peak Temp (3)	Op Temp (°C)	Device Marking (4/5)	Samples
SN74LV595AD	ACTIVE	SOIC	D	16	40	Green (RoHS & no Sb/Br)	CU NIPDAU	Level-1-260C-UNLIM	-40 to 125	LV595A	Samples
SN74LV595ADR	ACTIVE	SOIC	D	16	2500	Green (RoHS & no Sb/Br)	CU NIPDAU CU SN	Level-1-260C-UNLIM	-40 to 125	LV595A	Samples
SN74LV595ADRG3	ACTIVE	SOIC	D	16	2500	Green (RoHS & no Sb/Br)	CU SN	Level-1-260C-UNLIM	-40 to 125	LV595A	Samples
SN74LV595ADRG4	ACTIVE	SOIC	D	16	2500	Green (RoHS & no Sb/Br)	CU NIPDAU	Level-1-260C-UNLIM	-40 to 125	LV595A	Samples
SN74LV595ANSR	ACTIVE	SO	NS	16	2000	Green (RoHS & no Sb/Br)	CU NIPDAU	Level-1-260C-UNLIM	-40 to 125	74LV595A	Samples
SN74LV595APWR	ACTIVE	TSSOP	PW	16	2000	Green (RoHS & no Sb/Br)	CU NIPDAU CU SN	Level-1-260C-UNLIM	-40 to 125	LV595A	Samples
SN74LV595APWRG3	ACTIVE	TSSOP	PW	16	2000	Green (RoHS & no Sb/Br)	CU SN	Level-1-260C-UNLIM	-40 to 125	LV595A	Samples
SN74LV595APWRG4	ACTIVE	TSSOP	PW	16	2000	Green (RoHS & no Sb/Br)	CU NIPDAU	Level-1-260C-UNLIM	-40 to 125	LV595A	Samples
SN74LV595APWT	ACTIVE	TSSOP	PW	16	250	Green (RoHS & no Sb/Br)	CU NIPDAU	Level-1-260C-UNLIM	-40 to 125	LV595A	Samples
SN74LV595ARGYR	ACTIVE	VQFN	RGY	16	3000	Green (RoHS & no Sb/Br)	CU NIPDAU	Level-2-260C-1 YEAR	-40 to 125	LV595A	Samples
SN74LV595ARGYRG4	ACTIVE	VQFN	RGY	16	3000	Green (RoHS & no Sb/Br)	CU NIPDAU	Level-2-260C-1 YEAR	-40 to 125	LV595A	Samples

(1) The marketing status values are defined as follows:

ACTIVE: Product device recommended for new designs.

LIFEBUY: TI has announced that the device will be discontinued, and a lifetime-buy period is in effect.

NRND: Not recommended for new designs. Device is in production to support existing customers, but TI does not recommend using this part in a new design.

PREVIEW: Device has been announced but is not in production. Samples may or may not be available.

OBSOLETE: TI has discontinued the production of the device.

(2) **RoHS:** TI defines "RoHS" to mean semiconductor products that are compliant with the current EU RoHS requirements for all 10 RoHS substances, including the requirement that RoHS substance do not exceed 0.1% by weight in homogeneous materials. Where designed to be soldered at high temperatures, "RoHS" products are suitable for use in specified lead-free processes. TI may reference these types of products as "Pb-Free".

RoHS Exempt: TI defines "RoHS Exempt" to mean products that contain lead but are compliant with EU RoHS pursuant to a specific EU RoHS exemption.

Green: TI defines "Green" to mean the content of Chlorine (Cl) and Bromine (Br) based flame retardants meet JS709B low halogen requirements of <=1000ppm threshold. Antimony trioxide based flame retardants must also meet the <=1000ppm threshold requirement.

- (3) MSL, Peak Temp. - The Moisture Sensitivity Level rating according to the JEDEC industry standard classifications, and peak solder temperature.
- (4) There may be additional marking, which relates to the logo, the lot trace code information, or the environmental category on the device.
- (5) Multiple Device Markings will be inside parentheses. Only one Device Marking contained in parentheses and separated by a "~" will appear on a device. If a line is indented then it is a continuation of the previous line and the two combined represent the entire Device Marking for that device.
- (6) Lead/Ball Finish - Orderable Devices may have multiple material finish options. Finish options are separated by a vertical ruled line. Lead/Ball Finish values may wrap to two lines if the finish value exceeds the maximum column width.

Important Information and Disclaimer:The information provided on this page represents TI's knowledge and belief as of the date that it is provided. TI bases its knowledge and belief on information provided by third parties, and makes no representation or warranty as to the accuracy of such information. Efforts are underway to better integrate information from third parties. TI has taken and continues to take reasonable steps to provide representative and accurate information but may not have conducted destructive testing or chemical analysis on incoming materials and chemicals. TI and TI suppliers consider certain information to be proprietary, and thus CAS numbers and other limited information may not be available for release.

In no event shall TI's liability arising out of such information exceed the total purchase price of the TI part(s) at issue in this document sold by TI to Customer on an annual basis.

OTHER QUALIFIED VERSIONS OF SN74LV595A :

- Automotive: [SN74LV595A-Q1](#)
- Enhanced Product: [SN74LV595A-EP](#)

NOTE: Qualified Version Definitions:

- Automotive - Q100 devices qualified for high-reliability automotive applications targeting zero defects
- Enhanced Product - Supports Defense, Aerospace and Medical Applications

TAPE AND REEL INFORMATION

QUADRANT ASSIGNMENTS FOR PIN 1 ORIENTATION IN TAPE

*All dimensions are nominal

Device	Package Type	Package Drawing	Pins	SPQ	Reel Diameter (mm)	Reel Width W1 (mm)	A0 (mm)	B0 (mm)	K0 (mm)	P1 (mm)	W (mm)	Pin1 Quadrant
SN74LV595ADR	SOIC	D	16	2500	330.0	16.4	6.5	10.3	2.1	8.0	16.0	Q1
SN74LV595ADR	SOIC	D	16	2500	330.0	16.8	6.5	10.3	2.1	8.0	16.0	Q1
SN74LV595ADRG3	SOIC	D	16	2500	330.0	16.8	6.5	10.3	2.1	8.0	16.0	Q1
SN74LV595ADRG4	SOIC	D	16	2500	330.0	16.4	6.5	10.3	2.1	8.0	16.0	Q1
SN74LV595ANSR	SO	NS	16	2000	330.0	16.4	8.2	10.5	2.5	12.0	16.0	Q1
SN74LV595APWR	TSSOP	PW	16	2000	330.0	12.4	6.9	5.6	1.6	8.0	12.0	Q1
SN74LV595APWR	TSSOP	PW	16	2000	330.0	12.4	6.9	5.6	1.6	8.0	12.0	Q1
SN74LV595APWRG3	TSSOP	PW	16	2000	330.0	12.4	6.9	5.6	1.6	8.0	12.0	Q1
SN74LV595APWRG4	TSSOP	PW	16	2000	330.0	12.4	6.9	5.6	1.6	8.0	12.0	Q1
SN74LV595APWT	TSSOP	PW	16	250	330.0	12.4	6.9	5.6	1.6	8.0	12.0	Q1
SN74LV595ARGYR	VQFN	RGY	16	3000	330.0	12.4	3.8	4.3	1.5	8.0	12.0	Q1

TAPE AND REEL BOX DIMENSIONS

*All dimensions are nominal

Device	Package Type	Package Drawing	Pins	SPQ	Length (mm)	Width (mm)	Height (mm)
SN74LV595ADR	SOIC	D	16	2500	333.2	345.9	28.6
SN74LV595ADR	SOIC	D	16	2500	364.0	364.0	27.0
SN74LV595ADRG3	SOIC	D	16	2500	364.0	364.0	27.0
SN74LV595ADRG4	SOIC	D	16	2500	333.2	345.9	28.6
SN74LV595ANSR	SO	NS	16	2000	367.0	367.0	38.0
SN74LV595APWR	TSSOP	PW	16	2000	364.0	364.0	27.0
SN74LV595APWR	TSSOP	PW	16	2000	367.0	367.0	35.0
SN74LV595APWRG3	TSSOP	PW	16	2000	364.0	364.0	27.0
SN74LV595APWRG4	TSSOP	PW	16	2000	367.0	367.0	35.0
SN74LV595APWT	TSSOP	PW	16	250	367.0	367.0	35.0
SN74LV595ARGYR	VQFN	RGY	16	3000	367.0	367.0	35.0

D (R-PDSO-G16)

PLASTIC SMALL OUTLINE



- NOTES:
- A. All linear dimensions are in inches (millimeters).
 - B. This drawing is subject to change without notice.
 - C. Body length does not include mold flash, protrusions, or gate burrs. Mold flash, protrusions, or gate burrs shall not exceed 0.006 (0,15) each side.
 - D. Body width does not include interlead flash. Interlead flash shall not exceed 0.017 (0,43) each side.
 - E. Reference JEDEC MS-012 variation AC.

D (R-PDSO-G16)

PLASTIC SMALL OUTLINE



4211283-4/E 08/12

- NOTES:
- All linear dimensions are in millimeters.
 - This drawing is subject to change without notice.
 - Publication IPC-7351 is recommended for alternate designs.
 - Laser cutting apertures with trapezoidal walls and also rounding corners will offer better paste release. Customers should contact their board assembly site for stencil design recommendations. Refer to IPC-7525 for other stencil recommendations.
 - Customers should contact their board fabrication site for solder mask tolerances between and around signal pads.



NOTES:

1. All linear dimensions are in millimeters. Any dimensions in parenthesis are for reference only. Dimensioning and tolerancing per ASME Y14.5M.
2. This drawing is subject to change without notice.
3. This dimension does not include mold flash, protrusions, or gate burrs. Mold flash, protrusions, or gate burrs shall not exceed 0.15 mm per side.
4. This dimension does not include interlead flash. Interlead flash shall not exceed 0.25 mm per side.
5. Reference JEDEC registration MO-153.

EXAMPLE BOARD LAYOUT

PW0016A

TSSOP - 1.2 mm max height

SMALL OUTLINE PACKAGE



LAND PATTERN EXAMPLE
EXPOSED METAL SHOWN
SCALE: 10X



4220204/A 02/2017

NOTES: (continued)

- 6. Publication IPC-7351 may have alternate designs.
- 7. Solder mask tolerances between and around signal pads can vary based on board fabrication site.

EXAMPLE STENCIL DESIGN

PW0016A

TSSOP - 1.2 mm max height

SMALL OUTLINE PACKAGE



SOLDER PASTE EXAMPLE
BASED ON 0.125 mm THICK STENCIL
SCALE: 10X

4220204/A 02/2017

NOTES: (continued)

8. Laser cutting apertures with trapezoidal walls and rounded corners may offer better paste release. IPC-7525 may have alternate design recommendations.
9. Board assembly site may have different recommendations for stencil design.

MECHANICAL DATA

NS (R-PDSO-G**)

PLASTIC SMALL-OUTLINE PACKAGE

14-PINS SHOWN



- NOTES:
- A. All linear dimensions are in millimeters.
 - B. This drawing is subject to change without notice.
 - C. Body dimensions do not include mold flash or protrusion, not to exceed 0,15.

RGY (R-PVQFN-N16)

PLASTIC QUAD FLATPACK NO-LEAD

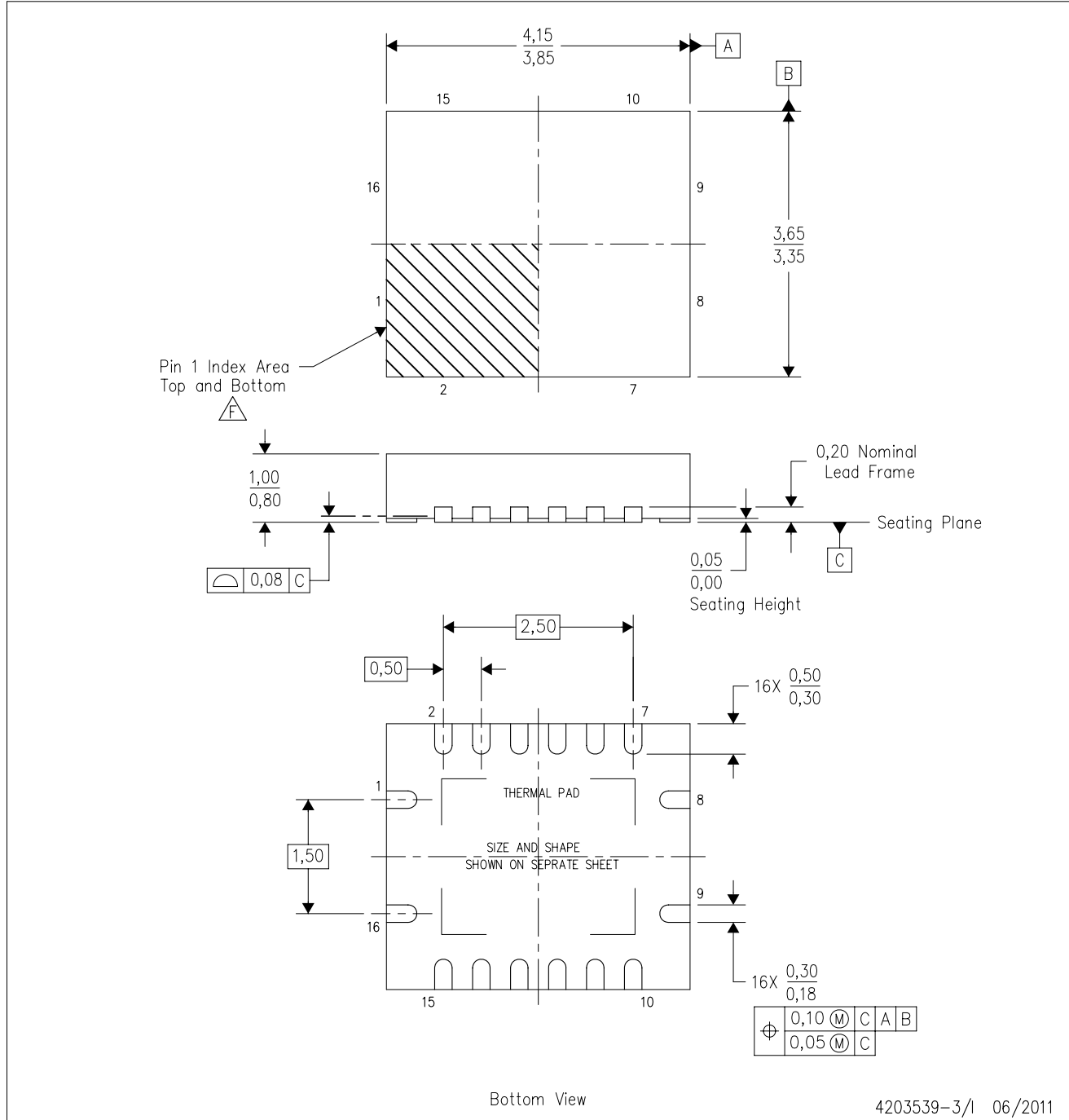

- NOTES:
- A. All linear dimensions are in millimeters. Dimensioning and tolerancing per ASME Y14.5M-1994.
 - B. This drawing is subject to change without notice.
 - C. QFN (Quad Flatpack No-Lead) package configuration.
 - D. The package thermal pad must be soldered to the board for thermal and mechanical performance.
 - E. See the additional figure in the Product Data Sheet for details regarding the exposed thermal pad features and dimensions.
 - △ Pin 1 identifiers are located on both top and bottom of the package and within the zone indicated. The Pin 1 identifiers are either a molded, marked, or metal feature.
 - G. Package complies to JEDEC MO-241 variation BA.

RGY (R-PVQFN-N16)

PLASTIC QUAD FLATPACK NO-LEAD

THERMAL INFORMATION

This package incorporates an exposed thermal pad that is designed to be attached directly to an external heatsink. The thermal pad must be soldered directly to the printed circuit board (PCB). After soldering, the PCB can be used as a heatsink. In addition, through the use of thermal vias, the thermal pad can be attached directly to the appropriate copper plane shown in the electrical schematic for the device, or alternatively, can be attached to a special heatsink structure designed into the PCB. This design optimizes the heat transfer from the integrated circuit (IC).

For information on the Quad Flatpack No-Lead (QFN) package and its advantages, refer to Application Report, QFN/SON PCB Attachment, Texas Instruments Literature No. SLUA271. This document is available at www.ti.com.

The exposed thermal pad dimensions for this package are shown in the following illustration.



Bottom View

Exposed Thermal Pad Dimensions

4206353-3/P 03/14

NOTE: All linear dimensions are in millimeters

RGY (R-PVQFN-N16)

PLASTIC QUAD FLATPACK NO-LEAD



4208122-3/P 03/14

- NOTES:
- A. All linear dimensions are in millimeters.
 - B. This drawing is subject to change without notice.
 - C. Publication IPC-7351 is recommended for alternate designs.
 - D. This package is designed to be soldered to a thermal pad on the board. Refer to Application Note, Quad Flat-Pack QFN/SON PCB Attachment, Texas Instruments Literature No. SLUA271, and also the Product Data Sheets for specific thermal information, via requirements, and recommended board layout. These documents are available at www.ti.com <<http://www.ti.com>>.
 - E. Laser cutting apertures with trapezoidal walls and also rounding corners will offer better paste release. Customers should contact their board assembly site for stencil design recommendations. Refer to IPC 7525 for stencil design considerations.
 - F. Customers should contact their board fabrication site for minimum solder mask web tolerances between signal pads.

IMPORTANT NOTICE AND DISCLAIMER

TI PROVIDES TECHNICAL AND RELIABILITY DATA (INCLUDING DATASHEETS), DESIGN RESOURCES (INCLUDING REFERENCE DESIGNS), APPLICATION OR OTHER DESIGN ADVICE, WEB TOOLS, SAFETY INFORMATION, AND OTHER RESOURCES "AS IS" AND WITH ALL FAULTS, AND DISCLAIMS ALL WARRANTIES, EXPRESS AND IMPLIED, INCLUDING WITHOUT LIMITATION ANY IMPLIED WARRANTIES OF MERCHANTABILITY, FITNESS FOR A PARTICULAR PURPOSE OR NON-INFRINGEMENT OF THIRD PARTY INTELLECTUAL PROPERTY RIGHTS.

These resources are intended for skilled developers designing with TI products. You are solely responsible for (1) selecting the appropriate TI products for your application, (2) designing, validating and testing your application, and (3) ensuring your application meets applicable standards, and any other safety, security, or other requirements. These resources are subject to change without notice. TI grants you permission to use these resources only for development of an application that uses the TI products described in the resource. Other reproduction and display of these resources is prohibited. No license is granted to any other TI intellectual property right or to any third party intellectual property right. TI disclaims responsibility for, and you will fully indemnify TI and its representatives against, any claims, damages, costs, losses, and liabilities arising out of your use of these resources.

TI's products are provided subject to TI's Terms of Sale (www.ti.com/legal/termsofsale.html) or other applicable terms available either on ti.com or provided in conjunction with such TI products. TI's provision of these resources does not expand or otherwise alter TI's applicable warranties or warranty disclaimers for TI products.

Mailing Address: Texas Instruments, Post Office Box 655303, Dallas, Texas 75265
Copyright © 2019, Texas Instruments Incorporated

Looking for pricing, stock, or lifecycle information?

Click below to explore more details on WIN SOURCE:

 [View SN74LV595APWR on WIN SOURCE](#)

 [Texas Instruments](#) Information

Optimize Your Supply Chain with WIN SOURCE Solutions

-  Global Sourcing Solution
-  Obsolete Management
-  Cost Control Management
-  Shortage Management
-  Alternative Solution
-  Excess Inventory Management