

TOSHIBA CMOS Digital Integrated Circuit Silicon Monolithic

## TC74HC4051AP, TC74HC4051AF, TC74HC4051AFT TC74HC4052AP, TC74HC4052AF, TC74HC4052AFT TC74HC4053AP, TC74HC4053AF, TC74HC4053AFT

TC74HC4051AP/AF/AFT

8-Channel Analog  
 Multiplexer/Demultiplexer

TC74HC4052AP/AF/AFT

Dual 4-Channel Analog  
 Multiplexer/Demultiplexer

TC74HC4053AP/AF/AFT

Triple 2-Channel Analog  
 Multiplexer/Demultiplexer

The TC74HC4051A/4052A/4053A are high speed CMOS ANALOG MULTIPLEXER/DEMULTIPLEXER fabricated with silicon gate C<sup>2</sup>MOS technology. They achieve the high speed operation similar to equivalent LSTTL while maintaining the CMOS low power dissipation.

The TC74HC4051A has an 8 channel configuration, the TC74HC4052A has a 4 channel × 2 configuration and the TC74HC4053A has a 2 channel × 3 configuration.

The digital signal to the control terminal turns "ON" the corresponding switch of each channel a large amplitude signal (VCC - VEE) can then be switched by the small logical amplitude (VCC - GND) control signal.

For example, in the case of VCC = 5 V, GND = 0 V, VEE = -5 V, signals between -5 V and +5 V can be switched from the logical circuit with a single power supply of 5 V. As the ON-resistance of each switch is low, they can be connected to circuits with low input impedance.

All inputs are equipped with protection circuits against static discharge or transient excess voltage.

### Features

- High speed: t<sub>pd</sub> = 15 ns (typ.) at VCC = 5 V, VEE = 0 V
- Low power dissipation: ICC = 4 μA (max) at Ta = 25°C
- High noise immunity: V<sub>NIH</sub> = V<sub>NIL</sub> = 28% VCC (min)
- Low ON resistance: RON = 50 Ω (typ.) at VCC - VEE = 9 V
- High noise immunity: THD = 0.02% (typ.) at VCC - VEE = 9 V
- Pin and function compatible with 4051/4052/4053B

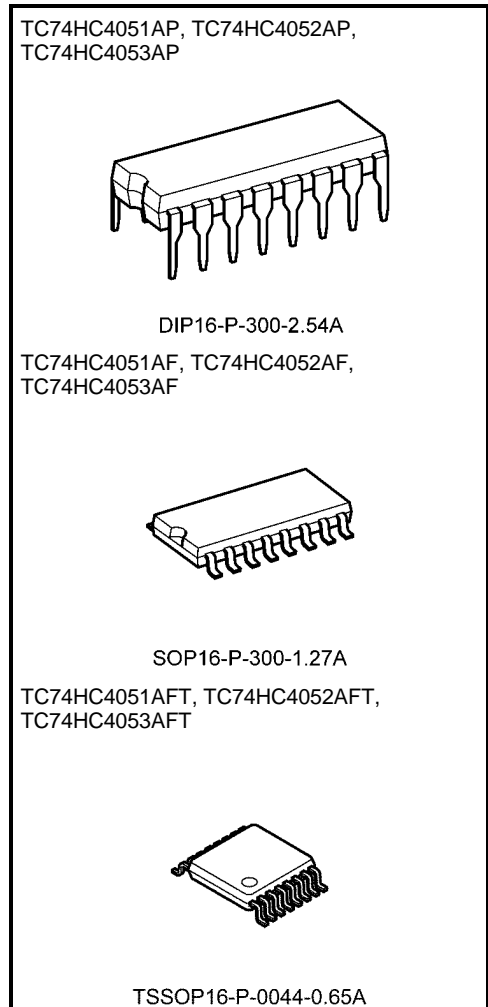

Weight	
DIP16-P-300-2.54A	: 1.00 g (typ.)
SOP16-P-300-1.27A	: 0.18 g (typ.)
TSSOP16-P-0044-0.65A	: 0.06 g (typ.)

Start of commercial production  
 1986-05

**Pin Assignment**

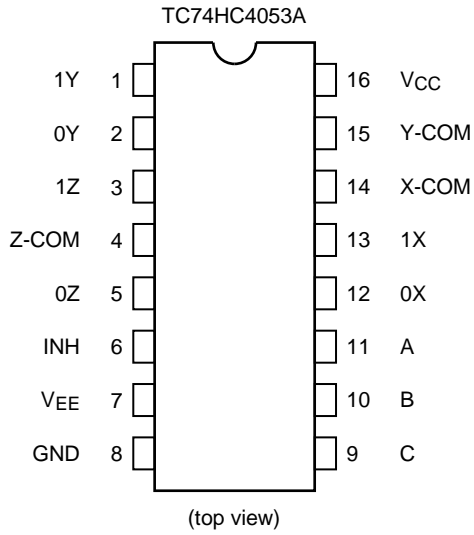
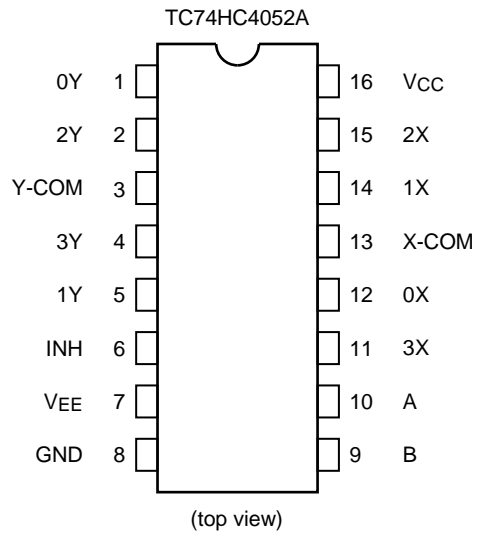
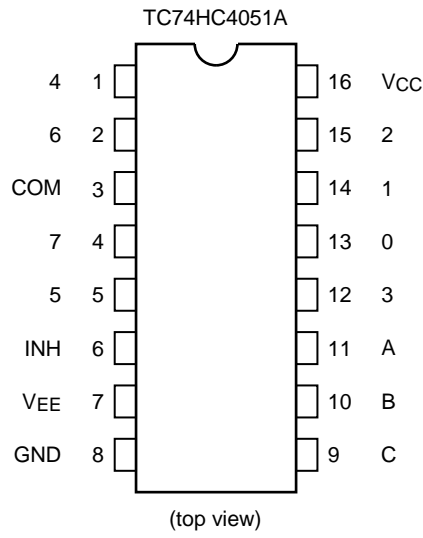

## IEC Logic Symbol

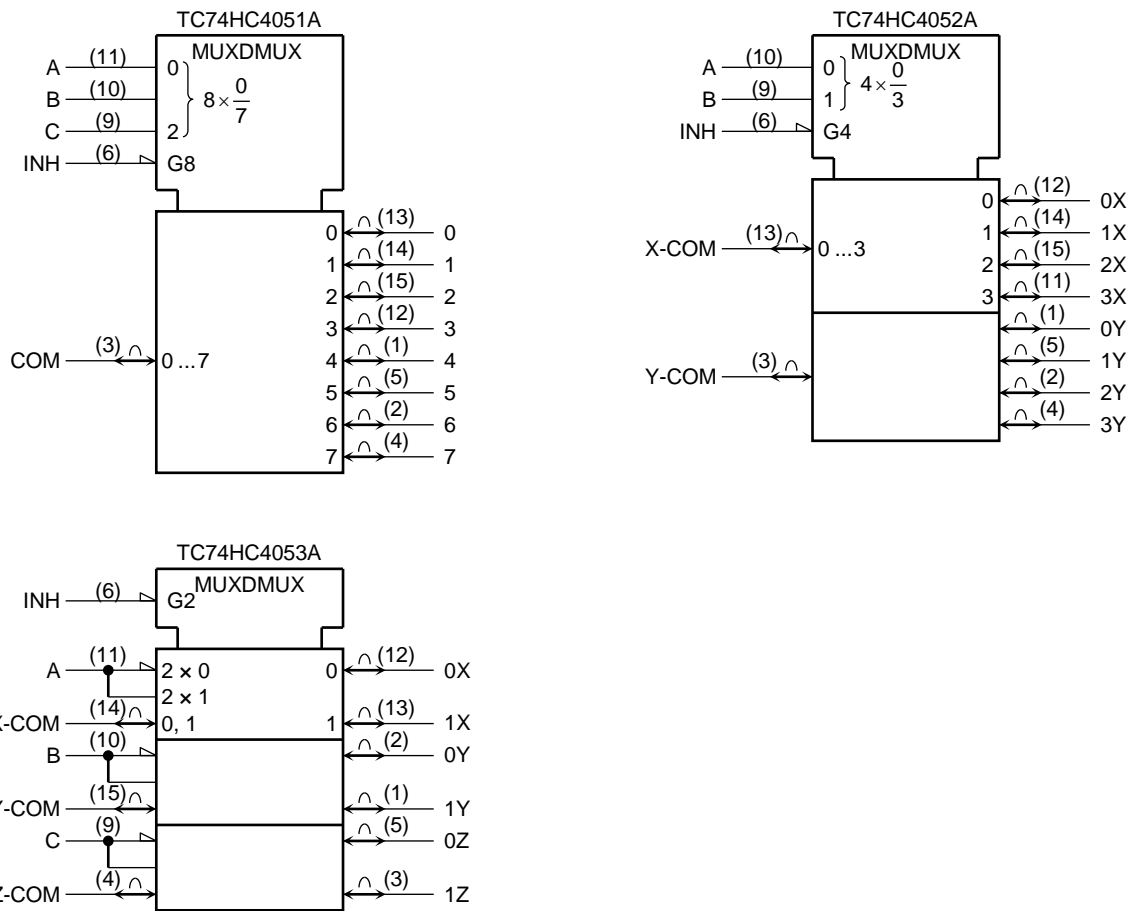

## Truth Table

Control Inputs				"ON" Channel		
Inhibit	C*	B	A	HC4051A	HC4052A	HC4053A
L	L	L	L	0	0X, 0Y	0X, 0Y, 0Z
L	L	L	H	1	1X, 1Y	1X, 0Y, 0Z
L	L	H	L	2	2X, 2Y	0X, 1Y, 0Z
L	L	H	H	3	3X, 3Y	1X, 1Y, 0Z
L	H	L	L	4	—	0X, 0Y, 1Z
L	H	L	H	5	—	1X, 0Y, 1Z
L	H	H	L	6	—	0X, 1Y, 1Z
L	H	H	H	7	—	1X, 1Y, 1Z
H	X	X	X	None	None	None

X: Don't care

\*: Except HC4052A

**System Diagram**

**TC74HC4051A**

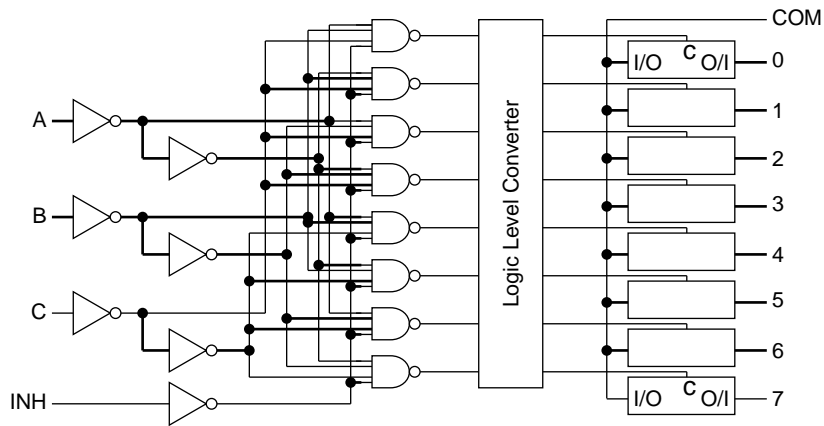

**TC74HC4052A**

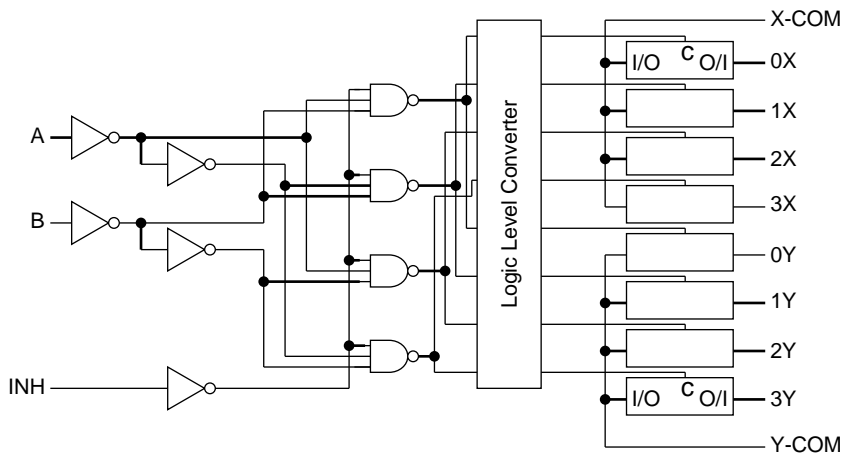

**TC74HC4053A**

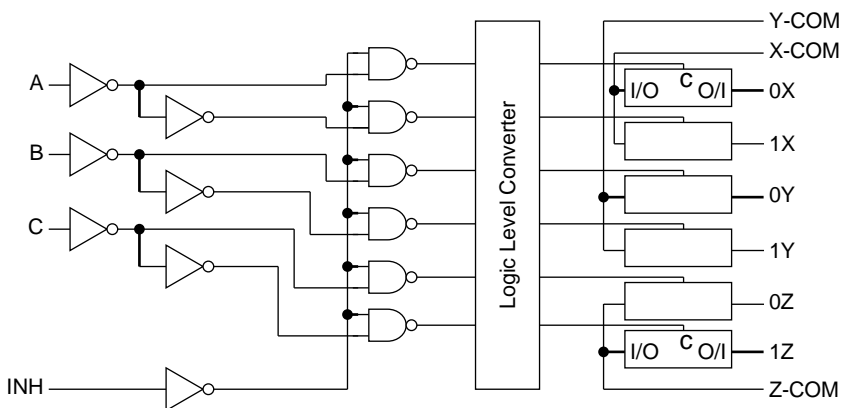

## Absolute Maximum Ratings (Note 1)

Characteristics	Symbol	Rating	Unit
Supply voltage range	V <sub>CC</sub>	-0.5 to 7	V
Supply voltage range	V <sub>CC</sub> -V <sub>EE</sub>	-0.5 to 13	V
Control input voltage	V <sub>IN</sub>	-0.5 to V <sub>CC</sub> + 0.5	V
Switch I/O voltage	V <sub>I/O</sub>	V <sub>EE</sub> - 0.5 to V <sub>CC</sub> + 0.5	V
Control input diode current	I <sub>CK</sub>	±20	mA
I/O diode current	I <sub>IOK</sub>	±20	mA
Switch through current	I <sub>T</sub>	±25	mA
DC V <sub>CC</sub> or ground current	I <sub>CC</sub>	±50	mA
Power dissipation	P <sub>D</sub>	500 (DIP) (Note 2)/180 (SOP/TSSOP)	mW
Storage temperature	T <sub>stg</sub>	-65 to 150	°C

Note 1: Exceeding any of the absolute maximum ratings, even briefly, lead to deterioration in IC performance or even destruction.

Using continuously under heavy loads (e.g. the application of high temperature/current/voltage and the significant change in temperature, etc.) may cause this product to decrease in the reliability significantly even if the operating conditions (i.e. operating temperature/current/voltage, etc.) are within the absolute maximum ratings and the operating ranges.

Please design the appropriate reliability upon reviewing the Toshiba Semiconductor Reliability Handbook ("Handling Precautions"/"Derating Concept and Methods") and individual reliability data (i.e. reliability test report and estimated failure rate, etc).

Note 2: 500 mW in the range of T<sub>a</sub> = -40 to 65°C. From T<sub>a</sub> = 65 to 85°C a derating factor of -10 mW/°C should be applied up to 300 mW.

## Operating Ranges (Note)

Characteristics	Symbol	Rating	Unit
Supply voltage range	V <sub>CC</sub>	2 to 6	V
Supply voltage range	V <sub>EE</sub>	-6 to 0	V
Supply voltage range	V <sub>CC</sub> -V <sub>EE</sub>	2 to 12	V
Control input voltage	V <sub>IN</sub>	0 to V <sub>CC</sub>	V
Switch I/O voltage	V <sub>I/O</sub>	V <sub>EE</sub> to V <sub>CC</sub>	V
Operating temperature	T <sub>opr</sub>	-40 to 85	°C
Control input rise and fall time	t <sub>r</sub> , t <sub>f</sub>	0 to 1000 (V <sub>CC</sub> = 2.0 V) 0 to 500 (V <sub>CC</sub> = 4.5 V) 0 to 400 (V <sub>CC</sub> = 6.0 V)	ns

Note: The operating ranges must be maintained to ensure the normal operation of the device. Unused control inputs must be tied to either V<sub>CC</sub> or GND.

## Electrical Characteristics

### DC Characteristics

Characteristics	Symbol	Test Condition		Ta = 25°C			Ta = -40 to 85°C		Unit		
		V <sub>EE</sub> (V)	V <sub>CC</sub> (V)	Min	Typ.	Max	Min	Max			
High-level control input voltage	V <sub>IHC</sub>	—	—	2.0	1.50	—	—	1.50	—	V	
				4.5	3.15	—	—	3.15	—		
				6.0	4.20	—	—	4.20	—		
Low-level control input voltage	V <sub>ILC</sub>	—	—	2.0	—	—	0.50	—	0.50	V	
				4.5	—	—	1.35	—	1.35		
				6.0	—	—	1.80	—	1.80		
ON resistance	R <sub>ON</sub>	V <sub>IN</sub> = V <sub>ILC</sub> or V <sub>IHC</sub> V <sub>I/O</sub> = V <sub>CC</sub> to V <sub>EE</sub> I <sub>I/O</sub> ≤ 2 mA	GND	4.5	—	85	180	—	225	Ω	
			-4.5	4.5	—	55	120	—	150		
			-6.0	6.0	—	50	100	—	125		
		GND	V <sub>IN</sub> = V <sub>ILC</sub> or V <sub>IHC</sub> V <sub>I/O</sub> = V <sub>CC</sub> or V <sub>EE</sub> I <sub>I/O</sub> ≤ 2 mA	2.0	—	150	—	—	—		
			4.5	—	70	150	—	190			
			-4.5	4.5	—	50	100	—	125		
-6.0	6.0	—	45	80	—	100					
	Difference of ON resistance between switches	ΔR <sub>ON</sub>	V <sub>IN</sub> = V <sub>ILC</sub> or V <sub>IHC</sub> V <sub>I/O</sub> = V <sub>CC</sub> to V <sub>EE</sub> I <sub>I/O</sub> ≤ 2 mA	GND	4.5	—	10	30	—	35	Ω
				-4.5	4.5	—	5	12	—	15	
-6.0				6.0	—	5	10	—	12		
Input/output leakage current (switch off)	I <sub>OFF</sub>	V <sub>OS</sub> = V <sub>CC</sub> or GND V <sub>IS</sub> = GND or V <sub>CC</sub> V <sub>IN</sub> = V <sub>ILC</sub> or V <sub>IHC</sub>	GND	6.0	—	—	±60	—	±600	nA	
			-6.0	6.0	—	—	±100	—	±1000		
			Switch input leakage current (switch on, output open)	I <sub>Iz</sub>	V <sub>OS</sub> = V <sub>CC</sub> or GND V <sub>IN</sub> = V <sub>ILC</sub> or V <sub>IHC</sub>	GND	6.0	—	—		±60
-6.0	6.0	—				—	±100	—	±1000		
Control input current	I <sub>IN</sub>	V <sub>IN</sub> = V <sub>CC</sub> or GND	GND	6.0	—	—	±0.1	—	±1.0	μA	
Quiescent supply current	I <sub>CC</sub>	V <sub>IN</sub> = V <sub>CC</sub> or GND	GND	6.0	—	—	4.0	—	40.0	μA	
			-6.0	6.0	—	—	8.0	—	80.0		

## AC Characteristics (CL = 50 pF, input: tr = tf = 6 ns, GND = 0 V)

Characteristics	Symbol	Test Condition		Ta = 25°C			Ta = -40 to 85°C		Unit	
				V <sub>EE</sub> (V)	V <sub>CC</sub> (V)	Min	Typ.	Max		Min
Phase difference between input and output	φ <sub>I/O</sub>	All types	GND	2.0	—	25	60	—	75	ns
			GND	4.5	—	6	12	—	15	
			GND	6.0	—	5	10	—	13	
			-4.5	4.5	—	4	—	—	—	
Output enable time	t <sub>pZL</sub> t <sub>pZH</sub>	4051A (Note 1)	GND	2.0	—	64	225	—	280	ns
			GND	4.5	—	18	45	—	56	
			GND	6.0	—	15	38	—	48	
			-4.5	4.5	—	18	—	—	—	
		4052A (Note 1)	GND	2.0	—	64	225	—	280	
			GND	4.5	—	18	45	—	56	
			GND	6.0	—	15	38	—	48	
			-4.5	4.5	—	18	—	—	—	
		4053A (Note 1)	GND	2.0	—	50	225	—	280	
			GND	4.5	—	14	45	—	56	
			GND	6.0	—	12	38	—	48	
			-4.5	4.5	—	14	—	—	—	
Output disable time	t <sub>pLZ</sub> t <sub>pHZ</sub>	4051A (Note 1)	GND	2.0	—	100	250	—	315	ns
			GND	4.5	—	33	50	—	63	
			GND	6.0	—	28	43	—	54	
			-4.5	4.5	—	29	—	—	—	
		4052A (Note 1)	GND	2.0	—	100	250	—	315	
			GND	4.5	—	33	50	—	63	
			GND	6.0	—	28	43	—	54	
			-4.5	4.5	—	29	—	—	—	
		4053A (Note 1)	GND	2.0	—	95	225	—	280	
			GND	4.5	—	30	45	—	56	
			GND	6.0	—	26	38	—	48	
			-4.5	4.5	—	26	—	—	—	
Control input capacitance	C <sub>IN</sub>	All types	—	—	—	5	10	—	10	pF
COMMON terminal capacitance	C <sub>IS</sub>	4051A	—	—	—	36	70	—	70	pF
		4052A	-5.0	5.0	—	19	40	—	40	
		4053A	—	—	—	11	20	—	20	
SWITCH terminal capacitance	C <sub>OS</sub>	4051A	—	—	—	7	15	—	15	pF
		4052A	-5.0	5.0	—	7	15	—	15	
		4053A	—	—	—	7	15	—	15	
Feedthrough capacitance	C <sub>IOS</sub>	4051A	—	—	—	0.95	2	—	2	pF
		4052A	-5.0	5.0	—	0.85	2	—	2	
		4053A	—	—	—	0.75	2	—	2	
Power dissipation capacitance	CPD	4051A (Note 2)	—	—	—	70	—	—	—	pF
		4052A (Note 2)	GND	5.0	—	71	—	—	—	
		4053A (Note 2)	—	—	—	67	—	—	—	

Note 1: R<sub>L</sub> = 1 kΩ

Note 2: CPD is defined as the value of the internal equivalent capacitance of IC which is calculated from the operating current consumption without load.

Average operating current can be obtained by the equation:

$$I_{CC}(\text{opr}) = CPD \cdot V_{CC} \cdot f_{IN} + I_{CC}$$

## Analog Switch Characteristics (GND = 0 V, Ta = 25°C) (Note 1)

Characteristics	Symbol	Test Condition			Typ.	Unit	
			V <sub>EE</sub> (V)	V <sub>CC</sub> (V)			
Sine wave distortion (T.H.D)		R <sub>L</sub> = 10 kΩ, V <sub>IN</sub> = 4.0 V <sub>p-p</sub>	-2.25	2.25	0.025	%	
		C <sub>L</sub> = 50 pF, V <sub>IN</sub> = 8.0 V <sub>p-p</sub>	-4.5	4.5	0.020		
		f <sub>IN</sub> = 1 kHz, V <sub>IN</sub> = 11.0 V <sub>p-p</sub>	-6.0	6.0	0.018		
Frequency response (switch on)	f <sub>max</sub>	Adjust f <sub>IN</sub> voltage to obtain 0dBm at V <sub>OS</sub> Increase f <sub>IN</sub> frequency until dB meter reads -3dB R <sub>L</sub> = 50 Ω, C <sub>L</sub> = 10 pF f <sub>IN</sub> = 1 MHz, sine wave	All (Note 2)	-2.25	2.25	120	MHz
			4051A (Note 3)			45	
			4052A (Note 3)			70	
			4053A (Note 3)			95	
			All (Note 2)	-4.5	4.5	190	
			4051A (Note 3)			70	
			4052A (Note 3)			110	
			4053A (Note 3)			150	
			All (Note 2)	-6.0	6.0	200	
			4051A (Note 3)			85	
			4052A (Note 3)			140	
			4053A (Note 3)			190	
Feed through attenuation (switch off)		V <sub>IN</sub> is centered at (V <sub>CC</sub> - V <sub>EE</sub> )/2 Adjust input for 0dBm R <sub>L</sub> = 600 Ω, C <sub>L</sub> = 50 pF f <sub>IN</sub> = 1 MHz, sine wave	-2.25	2.25	-50	dB	
			-4.5	4.5	-50		
			-6.0	6.0	-50		
Crosstalk (control input to signal output)		R <sub>L</sub> = 600 Ω, C <sub>L</sub> = 50 pF f <sub>IN</sub> = 1 MHz, square wave (t <sub>r</sub> = t <sub>f</sub> = 6 ns)	-2.25	2.25	60	mV	
			-4.5	4.5	140		
			-6.0	6.0	200		
Crosstalk (between any switches)		Adjust V <sub>IN</sub> to obtain 0dBm at input R <sub>L</sub> = 600 Ω, C <sub>L</sub> = 50 pF f <sub>IN</sub> = 1 MHz, sine wave	-2.25	2.25	-50	dB	
			-4.5	4.5	-50		
			-6.0	6.0	-50		

Note 1: These characteristics are determined by design of devices.

Note 2: Input COMMON terminal, and measured at SWITCH terminal.

Note 3: Input SWITCH terminal, and measured at COMMON terminal.

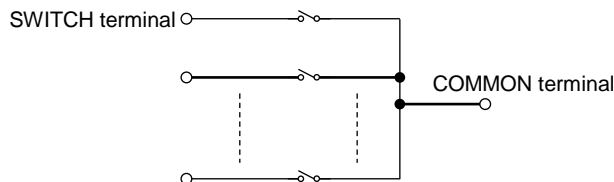

**Switching Characteristics Test Circuits**

**1.  $t_{pLZ}$ ,  $t_{pHZ}$ ,  $t_{pZL}$ ,  $t_{pZH}$**

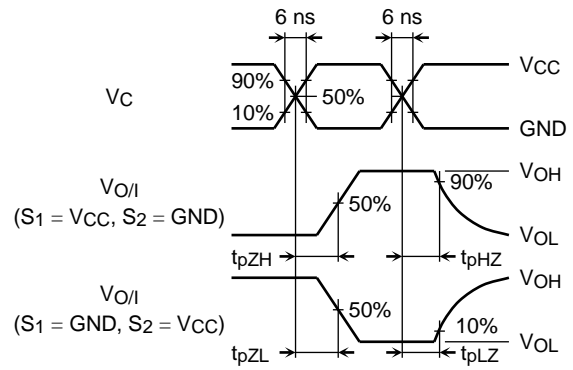
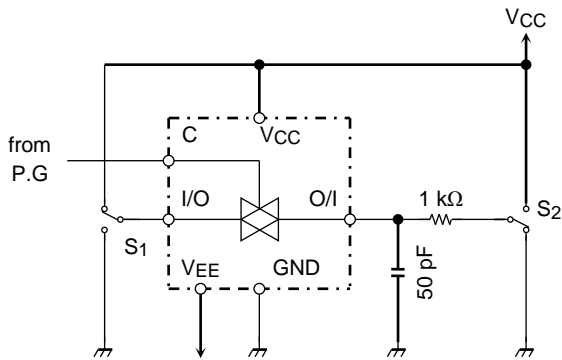

**2. Cross Talk (control input-switch output)  $f_{IN} = 1$  MHz duty = 50%  $t_r = t_f = 6$  ns**

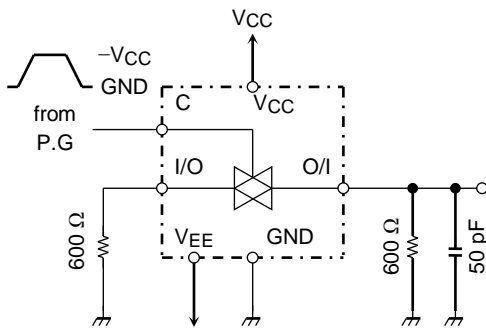

**3. Feedthrough Attenuation**

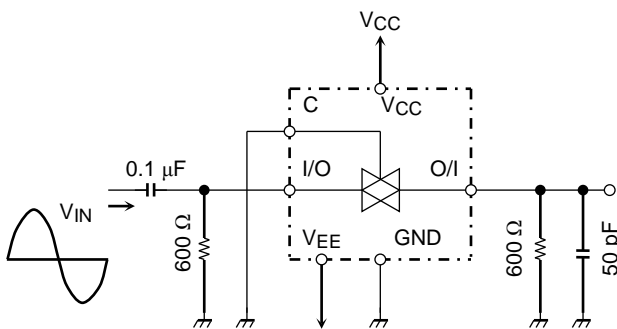

**4. Cios, Cis, Cos**

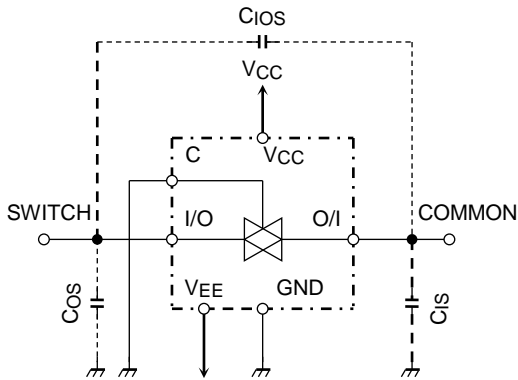

**5. Cross Talk (between any two switches)**

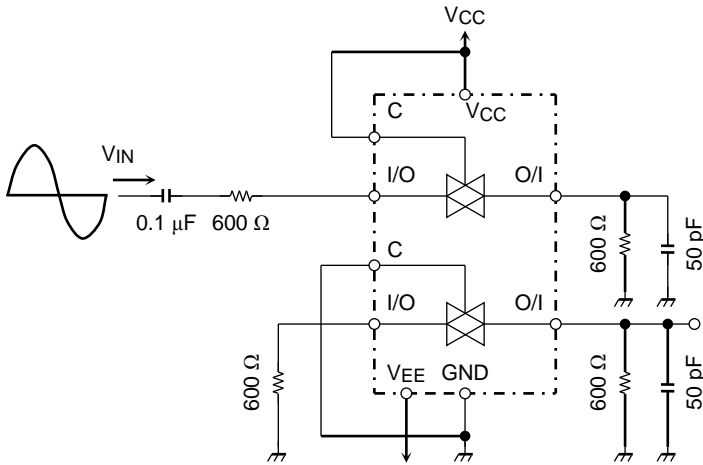

**6. Frequency Response (switch on)**

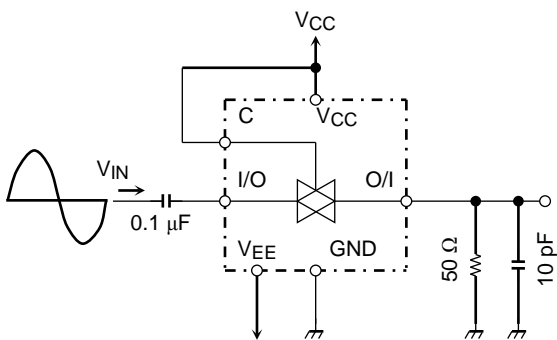

## Package Dimensions

DIP16-P-300-2.54A

Unit : mm

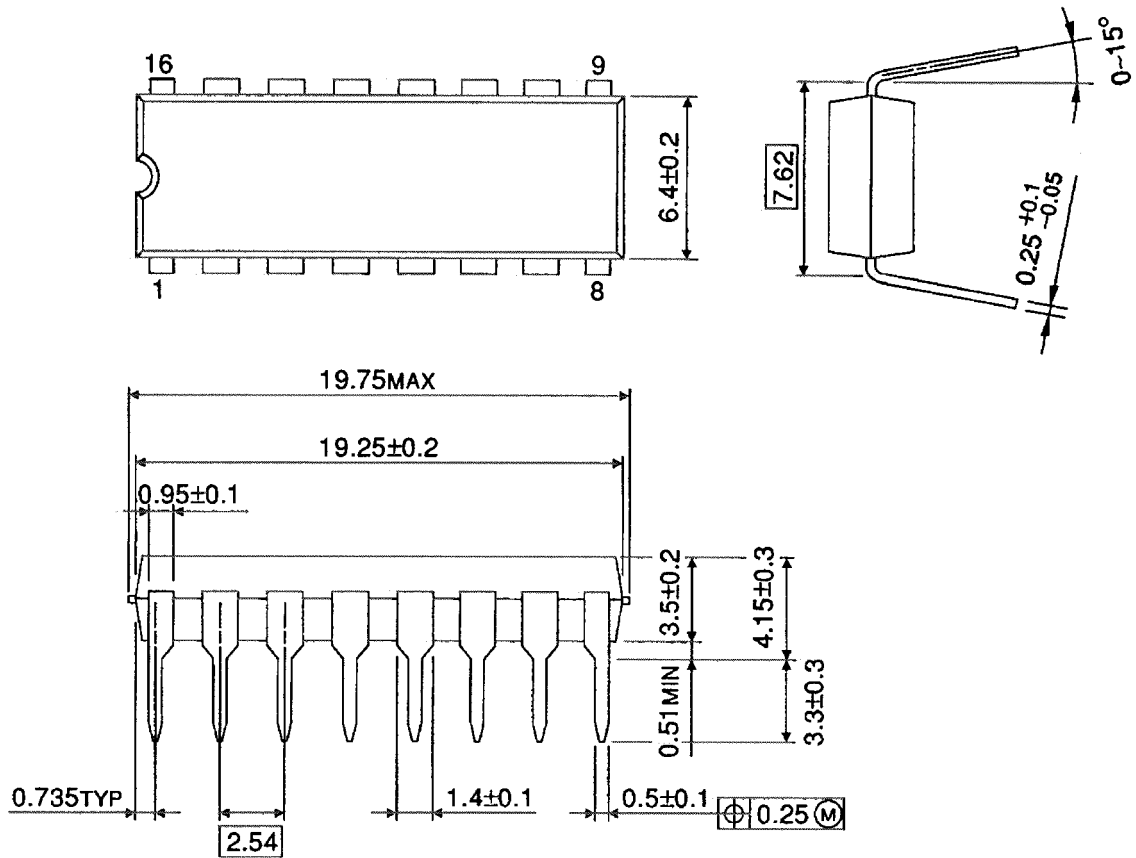

Weight: 1.00 g (typ.)

**Package Dimensions**

SOP16-P-300-1.27A

Unit: mm

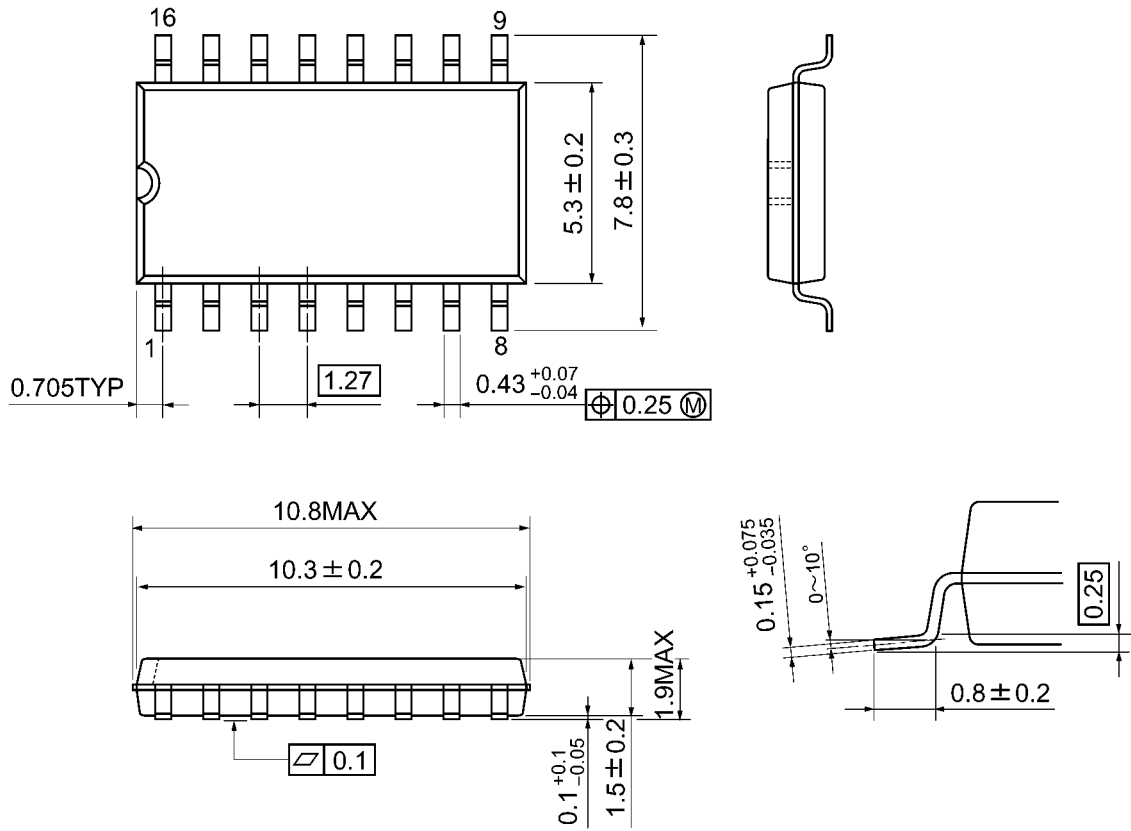

Weight: 0.18 g (typ.)

**Package Dimensions**

TSSOP16-P-0044-0.65A

Unit: mm

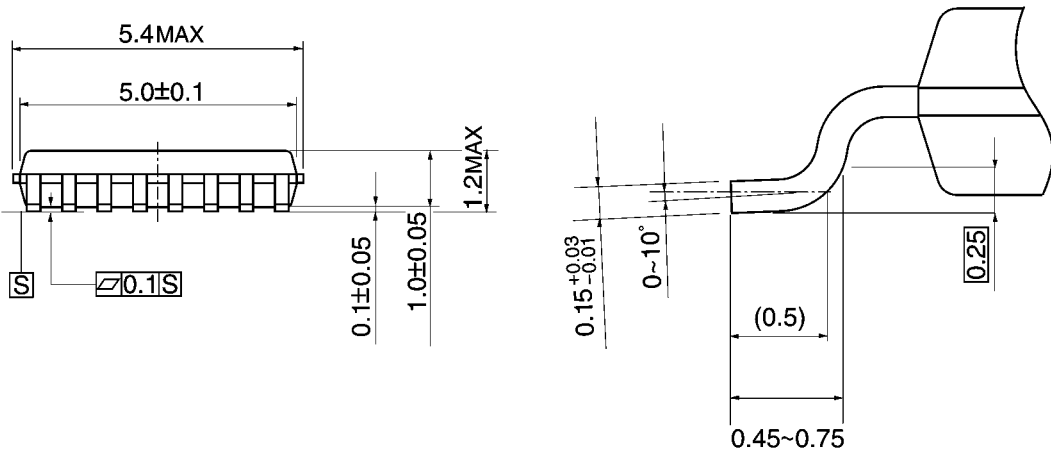
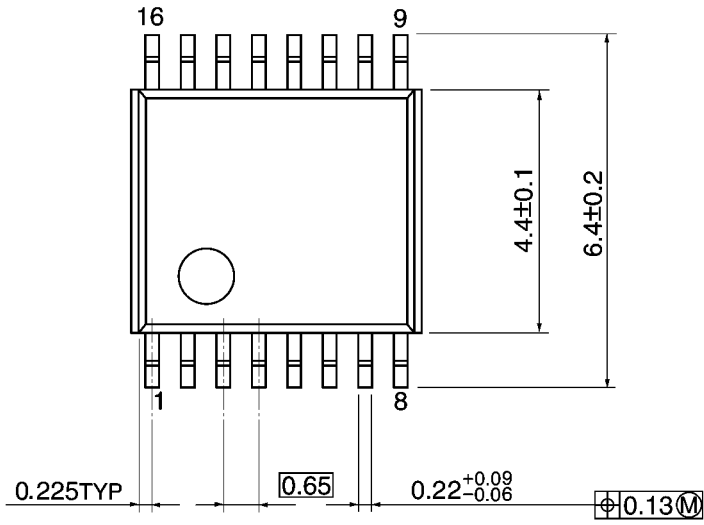

Weight: 0.06 g (typ.)

**RESTRICTIONS ON PRODUCT USE**

- Toshiba Corporation, and its subsidiaries and affiliates (collectively "TOSHIBA"), reserve the right to make changes to the information in this document, and related hardware, software and systems (collectively "Product") without notice.
- This document and any information herein may not be reproduced without prior written permission from TOSHIBA. Even with TOSHIBA's written permission, reproduction is permissible only if reproduction is without alteration/omission.
- Though TOSHIBA works continually to improve Product's quality and reliability, Product can malfunction or fail. Customers are responsible for complying with safety standards and for providing adequate designs and safeguards for their hardware, software and systems which minimize risk and avoid situations in which a malfunction or failure of Product could cause loss of human life, bodily injury or damage to property, including data loss or corruption. Before customers use the Product, create designs including the Product, or incorporate the Product into their own applications, customers must also refer to and comply with (a) the latest versions of all relevant TOSHIBA information, including without limitation, this document, the specifications, the data sheets and application notes for Product and the precautions and conditions set forth in the "TOSHIBA Semiconductor Reliability Handbook" and (b) the instructions for the application with which the Product will be used with or for. Customers are solely responsible for all aspects of their own product design or applications, including but not limited to (a) determining the appropriateness of the use of this Product in such design or applications; (b) evaluating and determining the applicability of any information contained in this document, or in charts, diagrams, programs, algorithms, sample application circuits, or any other referenced documents; and (c) validating all operating parameters for such designs and applications. **TOSHIBA ASSUMES NO LIABILITY FOR CUSTOMERS' PRODUCT DESIGN OR APPLICATIONS.**
- **PRODUCT IS NEITHER INTENDED NOR WARRANTED FOR USE IN EQUIPMENTS OR SYSTEMS THAT REQUIRE EXTRAORDINARILY HIGH LEVELS OF QUALITY AND/OR RELIABILITY, AND/OR A MALFUNCTION OR FAILURE OF WHICH MAY CAUSE LOSS OF HUMAN LIFE, BODILY INJURY, SERIOUS PROPERTY DAMAGE AND/OR SERIOUS PUBLIC IMPACT ("UNINTENDED USE").** Except for specific applications as expressly stated in this document, Unintended Use includes, without limitation, equipment used in nuclear facilities, equipment used in the aerospace industry, medical equipment, equipment used for automobiles, trains, ships and other transportation, traffic signaling equipment, equipment used to control combustions or explosions, safety devices, elevators and escalators, devices related to electric power, and equipment used in finance-related fields. **IF YOU USE PRODUCT FOR UNINTENDED USE, TOSHIBA ASSUMES NO LIABILITY FOR PRODUCT.** For details, please contact your TOSHIBA sales representative.
- Do not disassemble, analyze, reverse-engineer, alter, modify, translate or copy Product, whether in whole or in part.
- Product shall not be used for or incorporated into any products or systems whose manufacture, use, or sale is prohibited under any applicable laws or regulations.
- The information contained herein is presented only as guidance for Product use. No responsibility is assumed by TOSHIBA for any infringement of patents or any other intellectual property rights of third parties that may result from the use of Product. No license to any intellectual property right is granted by this document, whether express or implied, by estoppel or otherwise.
- **ABSENT A WRITTEN SIGNED AGREEMENT, EXCEPT AS PROVIDED IN THE RELEVANT TERMS AND CONDITIONS OF SALE FOR PRODUCT, AND TO THE MAXIMUM EXTENT ALLOWABLE BY LAW, TOSHIBA (1) ASSUMES NO LIABILITY WHATSOEVER, INCLUDING WITHOUT LIMITATION, INDIRECT, CONSEQUENTIAL, SPECIAL, OR INCIDENTAL DAMAGES OR LOSS, INCLUDING WITHOUT LIMITATION, LOSS OF PROFITS, LOSS OF OPPORTUNITIES, BUSINESS INTERRUPTION AND LOSS OF DATA, AND (2) DISCLAIMS ANY AND ALL EXPRESS OR IMPLIED WARRANTIES AND CONDITIONS RELATED TO SALE, USE OF PRODUCT, OR INFORMATION, INCLUDING WARRANTIES OR CONDITIONS OF MERCHANTABILITY, FITNESS FOR A PARTICULAR PURPOSE, ACCURACY OF INFORMATION, OR NONINFRINGEMENT.**
- Do not use or otherwise make available Product or related software or technology for any military purposes, including without limitation, for the design, development, use, stockpiling or manufacturing of nuclear, chemical, or biological weapons or missile technology products (mass destruction weapons). Product and related software and technology may be controlled under the applicable export laws and regulations including, without limitation, the Japanese Foreign Exchange and Foreign Trade Law and the U.S. Export Administration Regulations. Export and re-export of Product or related software or technology are strictly prohibited except in compliance with all applicable export laws and regulations.
- Please contact your TOSHIBA sales representative for details as to environmental matters such as the RoHS compatibility of Product. Please use Product in compliance with all applicable laws and regulations that regulate the inclusion or use of controlled substances, including without limitation, the EU RoHS Directive. **TOSHIBA ASSUMES NO LIABILITY FOR DAMAGES OR LOSSES OCCURRING AS A RESULT OF NONCOMPLIANCE WITH APPLICABLE LAWS AND REGULATIONS.**

## Looking for pricing, stock, or lifecycle information?

Click below to explore more details on WIN SOURCE:

- [View 74HC4053AF on WIN SOURCE](#)
- [Toshiba Semiconductor and Storage Information](#)

## Optimize Your Supply Chain with WIN SOURCE Solutions

- ✓ Global Sourcing Solution
- ✓ Obsolete Management
- ✓ Cost Control Management
- ✓ Shortage Management
- ✓ Alternative Solution
- ✓ Excess Inventory Management