



**THE DATASHEET OF  
SN74LV06APWR**



# SN74LV06A Hex Inverter Buffers/Drivers With Open-Drain Outputs

## 1 Features

- $V_{CC}$  operation of 2 V to 5.5 V
- Max  $t_{pd}$  of 6.5 ns at 5 V
- Typical  $V_{OLP}$  (Output Ground Bounce) < 0.8 V at  $V_{CC} = 3.3$  V,  $T_A = 25^\circ\text{C}$
- Typical  $V_{OHV}$  (Output  $V_{OH}$  Undershoot) > 2.3 V at  $V_{CC} = 3.3$  V,  $T_A = 25^\circ\text{C}$
- Outputs are disabled during power up and power down with inputs tied to  $V_{CC}$
- Support mixed-mode voltage operation on all ports
- $I_{off}$  supports live insertion, partial power down mode, and back drive protection
- Latch-up performance exceeds 100 mA per JESD 78, Class II

## 2 Applications

- Servers
- Telecom Infrastructures
- TV Set-Top Boxes
- UPS
- Printers
- Elevators, and Escalators
- EPOS, ECR, and Cash Drawers
- Vending, Payment, Cash Machines

## 3 Description

These hex inverter buffers/drivers are designed for 2 V to 5.5 V  $V_{CC}$  operation.

The SN74LV06A device performs the Boolean function  $Y = \bar{A}$  in positive logic.

The open-drain output require pull-up resistors to perform correctly and can be connected to other open-drain outputs to implement active-low wired-OR or active-high wired-AND functions.

### Package Information

PART NUMBER <sup>(1)</sup>	PACKAGE	BODY SIZE (NOM)
SN74LV06A	DGV (TVSOP, 14)	3.60 mm x 4.40 mm
	D (SOIC, 14)	8.65 mm x 3.90 mm
	NS (SO, 14)	10.20 mm x 5.30 mm
	DB (SSOP, 14)	6.20 mm x 5.30 mm
	PW (TSSOP, 14)	5.00 mm x 4.40 mm

(1) For all available packages, see the orderable addendum at the end of the data sheet.



Simplified Schematic



## Table of Contents

<b>1 Features</b> .....	1	8.1 Overview.....	8
<b>2 Applications</b> .....	1	8.2 Functional Block Diagram.....	8
<b>3 Description</b> .....	1	8.3 Feature Description.....	9
<b>4 Revision History</b> .....	2	8.4 Device Functional Modes.....	9
<b>5 Pin Configurations and Functions</b> .....	3	<b>9 Application and Implementation</b> .....	10
<b>6 Specifications</b> .....	4	9.1 Application Information.....	10
6.1 Absolute Maximum Ratings.....	4	9.2 Typical Application.....	10
6.2 ESD Ratings.....	4	9.3 Power Supply Recommendations.....	11
6.3 Recommended Operating Conditions.....	4	9.4 Layout.....	11
6.4 Thermal Information.....	5	<b>10 Device and Documentation Support</b> .....	12
6.5 Electrical Characteristics.....	5	10.1 Documentation Support.....	12
6.6 Switching Characteristics, $V_{CC} = 2.5\text{ V} \pm 0.2\text{ V}$ .....	5	10.2 Receiving Notification of Documentation Updates..	12
6.7 Switching Characteristics, $V_{CC} = 3.3\text{ V} \pm 0.3\text{ V}$ .....	5	10.3 Support Resources.....	12
6.8 Switching Characteristics, $V_{CC} = 5\text{ V} \pm 0.5\text{ V}$ .....	6	10.4 Trademarks.....	12
6.9 Noise Characteristics.....	6	10.5 Electrostatic Discharge Caution.....	12
6.10 Operating Characteristics.....	6	10.6 Glossary.....	12
6.11 Typical Characteristics.....	7	<b>11 Mechanical, Packaging, and Orderable Information</b> .....	12
<b>7 Parameter Measurement Information</b> .....	8		
<b>8 Detailed Description</b> .....	8		

## 4 Revision History

### Changes from Revision J (January 2016) to Revision K (March 2023) Page

- Updated structural layout of document and format of tables..... 1

### Changes from Revision I (February 2015) to Revision J (January 2016) Page

- Added  $T_J$  Junction temperature to the [Section 6.1](#) table ..... 4
- Changed [Figure 9-2](#) ..... 11

## 5 Pin Configurations and Functions

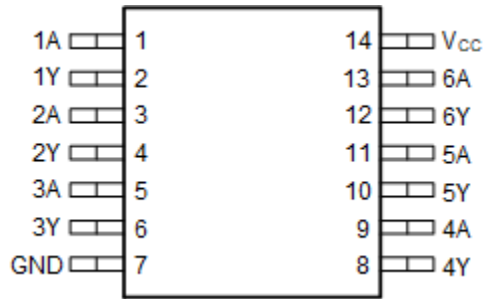

Figure 5-1. SN74LV06A D, DB, DGV, NS, or PW Package (Top View)

Table 5-1. Pin Functions

PIN		TYPE <sup>(1)</sup>	DESCRIPTION
NO.	NAME		
1	1A	I	Input 1
2	1Y	O	Output 1
3	2A	I	Input 2
4	2Y	O	Output 2
5	3A	I	Input 3
6	3Y	O	Output 3
8	4Y	O	Output 4
9	4A	I	Input 4
10	5Y	O	Output 5
11	5A	I	Input 5
12	6Y	O	Output 6
13	6A	I	Input 6
7	GND	GND	Ground Pin
14	V <sub>CC</sub>	—	Power Pin

(1) Signal Types: I = Input, O = Output, I/O = Input or Output, GND = Ground.

## 6 Specifications

### 6.1 Absolute Maximum Ratings

over operating free-air temperature range (unless otherwise noted)<sup>(1)</sup>

		MIN	MAX	UNIT
V <sub>CC</sub>	Supply voltage range	-0.5	7	V
V <sub>I</sub>	Input voltage range <sup>(2)</sup>	-0.5	7	V
V <sub>O</sub>	Voltage range applied to any output in the high-impedance or power-off state <sup>(2)</sup>	-0.5	7	V
I <sub>IK</sub>	Input clamp current	V <sub>I</sub> < 0	-20	mA
I <sub>OK</sub>	Output clamp current	V <sub>O</sub> < 0	-50	mA
I <sub>O</sub>	Continuous output current	V <sub>O</sub> = 0 to V <sub>CC</sub>	-35	mA
	Continuous current through V <sub>CC</sub> or GND		±50	mA
T <sub>stg</sub>	Storage temperature range	-65	150	°C
T <sub>J</sub>	Junction Temperature		150	°C

- (1) Stresses beyond those listed under *Absolute Maximum Ratings* may cause permanent damage to the device. These are stress ratings only, and functional operation of the device at these or any other conditions beyond those indicated under *Recommended Operating Conditions* is not implied. Exposure to absolute-maximum-rated conditions for extended periods may affect device reliability.
- (2) The input and output negative-voltage ratings may be exceeded if the input and output current ratings are observed.

### 6.2 ESD Ratings

		VALUE	UNIT
V <sub>(ESD)</sub>	Electrostatic discharge		
	Human-body model (HBM), per ANSI/ESDA/JEDEC JS-001 <sup>(1)</sup>	±2500	V
	Machine Model (MM), per JEDEC specification	±200	
Charged-device model (CDM), per JEDEC specification JESD22-C101 <sup>(2)</sup>	±2000		

- (1) JEDEC document JEP155 states that 500-V HBM allows safe manufacturing with a standard ESD control process. Manufacturing with less than 500-V HBM is possible with the necessary precautions.
- (2) JEDEC document JEP157 states that 250-V CDM allows safe manufacturing with a standard ESD control process. Manufacturing with less than 250-V CDM is possible with the necessary precautions.

### 6.3 Recommended Operating Conditions

over operating free-air temperature range (unless otherwise noted)<sup>(1)</sup>

		SN74LV06A		UNIT
		MIN	MAX	
V <sub>CC</sub>	Supply voltage	2	5.5	V
V <sub>IH</sub>	High level input voltage	V <sub>CC</sub> = 2 V	1.5	V
		V <sub>CC</sub> = 2.3 V to 2.7 V	V <sub>CC</sub> × 0.7	
		V <sub>CC</sub> = 3 V to 3.6 V	V <sub>CC</sub> × 0.7	
		V <sub>CC</sub> = 4.5 V to 5.5 V	V <sub>CC</sub> × 0.7	
V <sub>IL</sub>	Low level input voltage	V <sub>CC</sub> = 2 V	0.5	V
		V <sub>CC</sub> = 2.3 V to 2.7 V	V <sub>CC</sub> × 0.3	
		V <sub>CC</sub> = 3 V to 3.6 V	V <sub>CC</sub> × 0.3	
		V <sub>CC</sub> = 4.5 V to 5.5 V	V <sub>CC</sub> × 0.3	
V <sub>I</sub>	Input voltage	0	5.5	V
V <sub>O</sub>	Output voltage	0	5.5	V
I <sub>OL</sub>	Low level output current	V <sub>CC</sub> = 2 V	20	mA
		V <sub>CC</sub> = 2.3 V to 2.7 V	2	
		V <sub>CC</sub> = 3 V to 3.6 V	8	
		V <sub>CC</sub> = 4.5 V to 5.5 V	16	
Δt/Δv	Input transition rise and fall rate	V <sub>CC</sub> = 2.3 V to 2.7 V	200	ns/V
		V <sub>CC</sub> = 3 V to 3.6 V	100	
		V <sub>CC</sub> = 4.5 V to 5.5 V	20	

over operating free-air temperature range (unless otherwise noted)<sup>(1)</sup>

		SN74LV06A		UNIT
		MIN	MAX	
T <sub>A</sub>	Operating free-air temperature	-40	125	°C

(1) All unused inputs of the device must be held at V<sub>CC</sub> or GND to ensure proper device operation. Refer to the TI application report, *Implications of Slow or Floating CMOS Inputs (SCBA004)*.

## 6.4 Thermal Information

THERMAL METRIC <sup>(1)</sup>		SN74LV06A					UNIT
		D	DB	DGV	NS	PW	
		14 PINS	14 PINS	14 PINS	14 PINS	14 PINS	
R <sub>θJA</sub>	Junction-to-ambient thermal resistance	100.6	112.5	135.2	95.4	128.7	°C/W
R <sub>θJC(top)</sub>	Junction-to-case (top) thermal resistance	51.8	65.0	57.9	52.9	57.2	
R <sub>θJB</sub>	Junction-to-board thermal resistance	54.9	59.9	68.3	51.2	70.7	
ψ <sub>JT</sub>	Junction-to-top characterization parameter	25.0	25.0	9.2	17.9	9.3	
ψ <sub>JB</sub>	Junction-to-board characterization parameter	54.7	59.3	67.6	53.8	70.0	

(1) For more information about traditional and new thermal metrics, see the *IC Package Thermal Metrics* application report (SPRA953).

## 6.5 Electrical Characteristics

over recommended operating free-air temperature range (unless otherwise noted)

PARAMETER	TEST CONDITIONS	V <sub>CC</sub>	SN74LV06A			-40°C to 85°C SN74LV06A			-40°C to 125°C SN74LV06A		UNIT
			MIN	TYP	MAX	MIN	TYP	MAX	MIN	MAX	
V <sub>OL</sub>	I <sub>OL</sub> = 50 μA	2 V to 5.5 V			0.1			0.1		0.1	V
	I <sub>OL</sub> = 2 mA	2.3 V			0.4			0.4		0.4	
	I <sub>OL</sub> = 8 mA	3 V			0.44			0.44		0.44	
	I <sub>OL</sub> = 16 mA	4.5 V			0.55			0.55		0.55	
I <sub>I</sub>	V <sub>I</sub> = 5.5 V or GND	0 to 5.5 V			±1			±1		±1	μA
I <sub>OH</sub>	V <sub>I</sub> = V <sub>IL</sub> , V <sub>OH</sub> = V <sub>CC</sub>	5.5 V			±2.5			±2.5		±2.5	μA
I <sub>CC</sub>	V <sub>I</sub> = V <sub>CC</sub> or GND, I <sub>O</sub> = 0	5.5 V			20			20		20	μA
I <sub>off</sub>	V <sub>I</sub> or V <sub>O</sub> = 0 to 5.5 V	0			5			5		5	μA
C <sub>i</sub>	V <sub>I</sub> = V <sub>CC</sub> or GND	3.3 V		1.6			1.6			1.6	pF

## 6.6 Switching Characteristics, V<sub>CC</sub> = 2.5 V ± 0.2 V

over recommended operating free-air temperature range (unless otherwise noted) (see [Load Circuit and Voltage Waveforms](#))

PARAMETER	FROM (INPUT)	TO (OUTPUT)	LOAD CAPACITANCE	T <sub>A</sub> = 25°C			-40°C to 85°C SN74LV06A		-40°C to 125°C SN74LV06A		UNIT
				MIN	TYP	MAX	MIN	MAX	MIN	MAX	
t <sub>PLH</sub>	A	Y	C <sub>L</sub> = 15 pF	5.4 <sup>(1)</sup>	10.4 <sup>(1)</sup>		1 <sup>(1)</sup>	13 <sup>(1)</sup>	1	14	ns
t <sub>PHL</sub>				7.2 <sup>(1)</sup>	10.4 <sup>(1)</sup>		1 <sup>(1)</sup>	13 <sup>(1)</sup>	1	14	
t <sub>PLH</sub>	A	Y	C <sub>L</sub> = 50 pF	9.7	15.2		1	18	1	19	ns
t <sub>PHL</sub>				9.3	15.2		1	18	1	19	

(1) On products compliant to MIL-PRF-38535, this parameter is not production tested.

## 6.7 Switching Characteristics, V<sub>CC</sub> = 3.3 V ± 0.3 V

over recommended operating free-air temperature range (unless otherwise noted) (see [Load Circuit and Voltage Waveforms](#))

PARAMETER	FROM (INPUT)	TO (OUTPUT)	LOAD CAPACITANCE	T <sub>A</sub> = 25°C			-40°C to 85°C SN74LV06A		-40°C to 125°C SN74LV06A		UNIT
				MIN	TYP	MAX	MIN	MAX	MIN	MAX	
t <sub>PLH</sub>	A	Y	C <sub>L</sub> = 15 pF	4.1 <sup>(1)</sup>	7.1 <sup>(1)</sup>		1 <sup>(1)</sup>	8.5 <sup>(1)</sup>	1	9.5	ns
t <sub>PHL</sub>				4.9 <sup>(1)</sup>	7.1 <sup>(1)</sup>		1 <sup>(1)</sup>	8.5 <sup>(1)</sup>	1	9.5	

**SN74LV06A**

SCES336K – MAY 2000 – REVISED MARCH 2023

 over recommended operating free-air temperature range (unless otherwise noted) (see [Load Circuit and Voltage Waveforms](#))

PARAMETER	FROM (INPUT)	TO (OUTPUT)	LOAD CAPACITANCE	T <sub>A</sub> = 25°C			–40°C to 85°C SN74LV06A		–40°C to 125°C SN74LV06A		UNIT
				MIN	TYP	MAX	MIN	MAX	MIN	MAX	
t <sub>PLH</sub>	A	Y	C <sub>L</sub> = 50 pF	7.1	10.6	1	12	1	13	ns	
t <sub>PHL</sub>	A	Y		6.4	10.6	1	12	1	13		

(1) On products compliant to MIL-PRF-38535, this parameter is not production tested.

## 6.8 Switching Characteristics, V<sub>CC</sub> = 5 V ± 0.5 V

 operating free-air temperature range (unless otherwise noted) (see [Load Circuit and Voltage Waveforms](#))

PARAMETER	FROM (INPUT)	TO (OUTPUT)	LOAD CAPACITANCE	T <sub>A</sub> = 25°C			–40°C to 85°C SN74LV06A		–40°C to 125°C SN74LV06A		UNIT
				MIN	TYP	MAX	MIN	MAX	MIN	MAX	
t <sub>PLH</sub>	A	Y	C <sub>L</sub> = 15 pF	3 <sup>(1)</sup>	5.5 <sup>(1)</sup>	1 <sup>(1)</sup>	6.5 <sup>(1)</sup>	1	7	ns	
t <sub>PHL</sub>	A	Y		3.3 <sup>(1)</sup>	5.5 <sup>(1)</sup>	1 <sup>(1)</sup>	6.5 <sup>(1)</sup>	1	7		
t <sub>PLH</sub>	A	Y	C <sub>L</sub> = 50 pF	4.8	7.5	1	8.5	1	9	ns	
t <sub>PHL</sub>	A	Y		4.4	7.5	1	8.5	1	9		

(1) On products compliant to MIL-PRF-38535, this parameter is not production tested.

## 6.9 Noise Characteristics

 V<sub>CC</sub> = 3.3 V, C<sub>L</sub> = 50 pF, T<sub>A</sub> = 25°C

PARAMETER <sup>(1)</sup>		MIN	TYP	MAX	UNIT
V <sub>OL(P)</sub>	Quiet output, maximum dynamic V <sub>OL</sub>		0.5	0.8	V
V <sub>OL(V)</sub>	Quiet output, minimum dynamic V <sub>OL</sub>		–0.1	–0.8	V
V <sub>OH(V)</sub>	Quiet output, minimum dynamic V <sub>OH</sub>		3.3		V
V <sub>IH(D)</sub>	High-level dynamic input voltage	2.31			V
V <sub>IL(D)</sub>	Low-level dynamic input voltage			0.99	V

(1) Characteristics are for surface-mount packages only.

## 6.10 Operating Characteristics

 T<sub>A</sub> = 25°C

PARAMETER	TEST CONDITIONS	V <sub>CC</sub>	TYP	UNIT	
C <sub>pd</sub>	Power dissipation capacitance	C <sub>L</sub> = 50 pF      f = 10 MHz	3.3 V	2.6	pF
			5 V	4.7	

## 6.11 Typical Characteristics

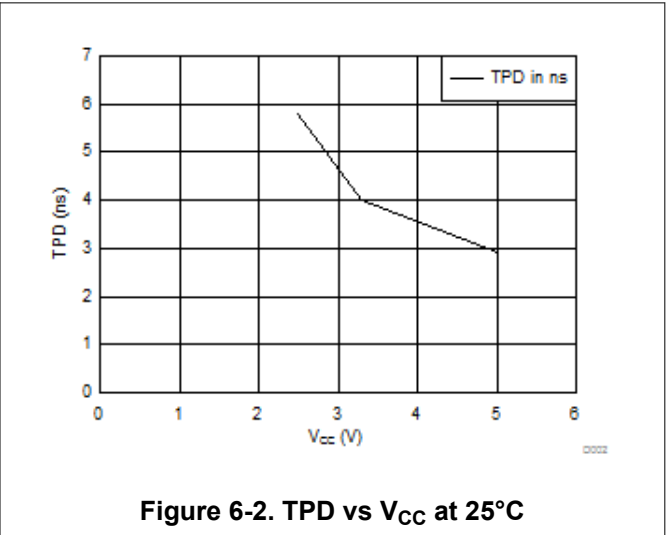
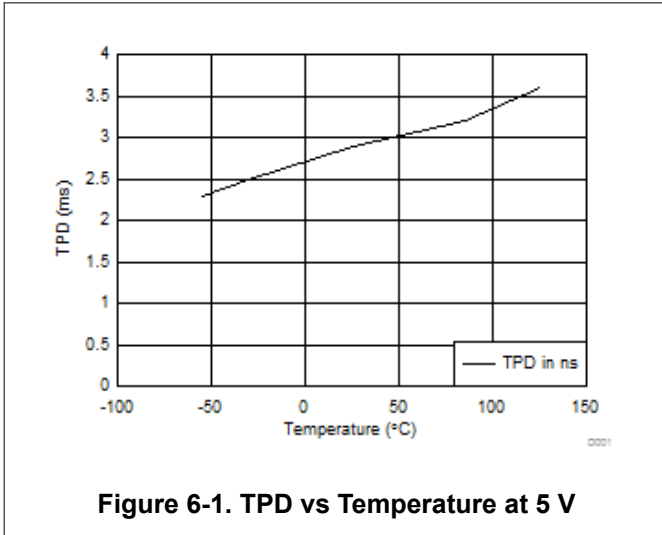

## 7 Parameter Measurement Information

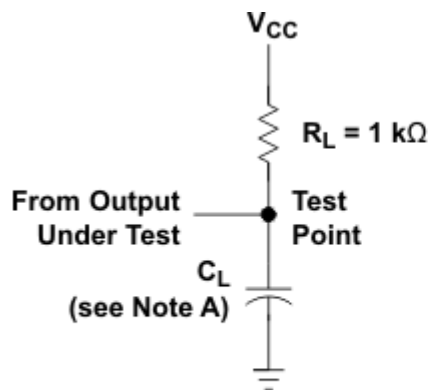

**LOAD CIRCUIT FOR  
OPEN-DRAIN OUTPUTS**

- A.  $C_L$  includes probe and jig capacitance.
- B. All input pulses are supplied by generators having the following characteristics:  $PRR \leq 1$  MHz,  $Z_O = 50 \Omega$ ,  $t_r \leq 3$  ns,  $t_f \leq 3$  ns.
- C. The outputs are measured one at a time, with one input transition per measurement.

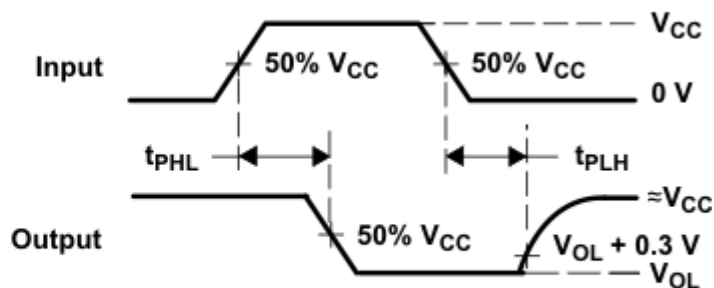

**VOLTAGE WAVEFORMS  
PROPAGATION DELAY TIMES**

**Figure 7-1. Load Circuit and Voltage Waveforms**

## 8 Detailed Description

### 8.1 Overview

These hex inverter buffers/drivers are designed for 2-V to 5.5-V  $V_{CC}$  operation.

The SN74LV06A device performs the Boolean function  $Y = \bar{A}$  in positive logic.

The open-drain output require pull-up resistors to perform correctly and can be connected to other open-drain outputs to implement active-low wired-OR or active-high wired-AND functions.

These devices are fully specified for partial-power-down applications using  $I_{off}$ . The  $I_{off}$  circuitry disables the outputs, preventing damaging current back-flow through the devices when they are powered down.

### 8.2 Functional Block Diagram

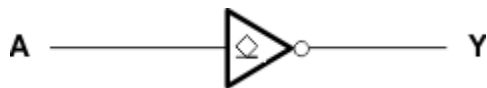

**Figure 8-1. Logic Diagram (Positive Logic)**

### 8.3 Feature Description

- Wide operating voltage range
  - Operates from 2 V to 5.5 V
- Allows up or down voltage translation
  - Inputs and outputs accept voltages to 5.5 V
- $I_{off}$  feature
  - Allows voltages on the inputs and outputs when  $V_{CC}$  is 0 V

### 8.4 Device Functional Modes

**Table 8-1. Function Table  
(Each Inverter)**

<b>INPUT<sup>(1)</sup> A</b>	<b>OUTPUT<sup>(2)</sup> Y</b>
H	L
L	H

- (1) H = High Voltage Level, L = Low Voltage Level  
(2) H = Driving High, L = Driving Low

## 9 Application and Implementation

### Note

Information in the following applications sections is not part of the TI component specification, and TI does not warrant its accuracy or completeness. TI's customers are responsible for determining suitability of components for their purposes, as well as validating and testing their design implementation to confirm system functionality.

### 9.1 Application Information

The SN74LV06A is a low drive Open drain CMOS device that can be used for a multitude of buffer type functions. The inputs are 5.5 V tolerant and the outputs open drain and 5.5 V tolerant allowing it to translate up to 5.5 V or down to any other voltage between GND and 5.5 V.

### 9.2 Typical Application

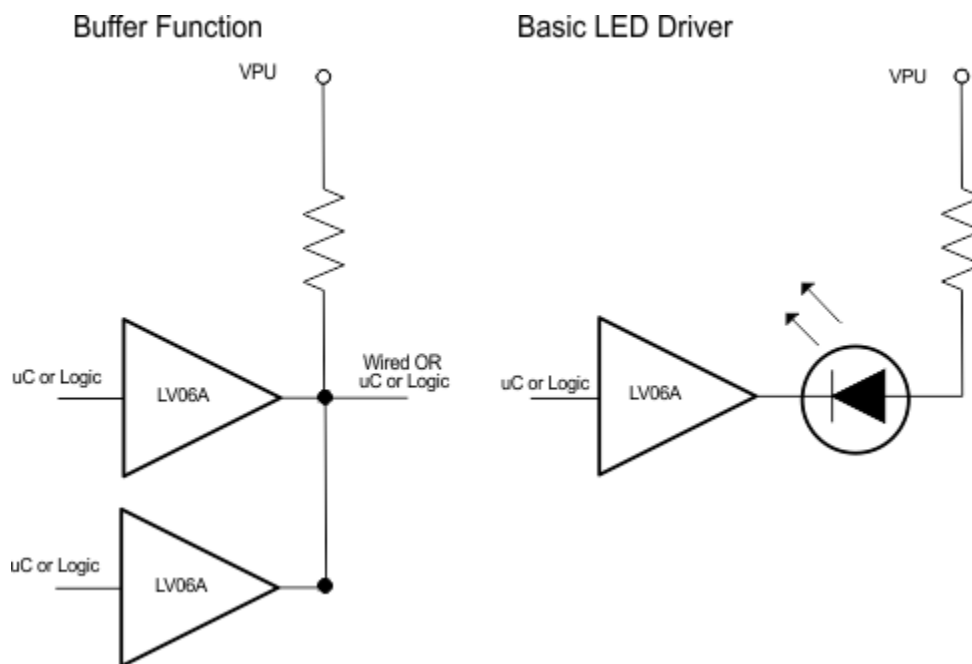

Figure 9-1. Typical Application Schematic

#### 9.2.1 Design Requirements

This device uses CMOS technology and is open drain so it has low output drive only. Care should be taken to avoid bus contention because it can drive currents that would exceed maximum limits. The parallel output drive can create fast edges into light loads so routing and load conditions should be considered to prevent ringing.

#### 9.2.2 Detailed Design Procedure

- Recommended Input Conditions:
  - For rise time and fall time specifications, see  $\Delta t/\Delta V$  in the [Section 6.3](#) table.
  - For specified high and low levels, see  $V_{IH}$  and  $V_{IL}$  in the [Section 6.3](#) table.
  - Inputs are overvoltage tolerant allowing them to go as high as 5.5 V at any valid  $V_{CC}$ .
- Recommended Output Conditions:
  - Load currents should not exceed 35 mA per output and 50 mA total for the part.

### 9.2.3 Application Curves

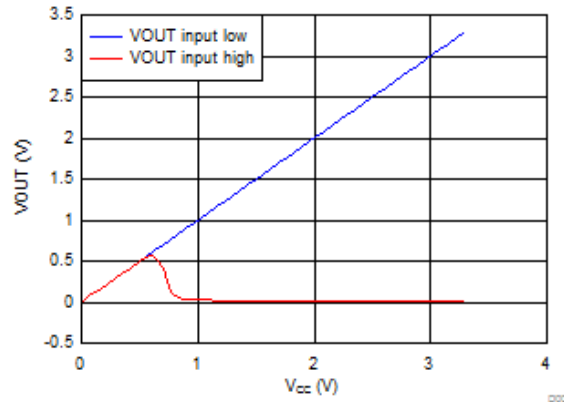

Figure 9-2. Output During Power Up with 4 k Pull-up at 3.3 V

### 9.3 Power Supply Recommendations

The power supply can be any voltage between the MIN and MAX supply voltage rating located in the [Section 6.3](#). Each  $V_{CC}$  terminal should have a good bypass capacitor to prevent power disturbance. For devices with a single supply, a 0.1  $\mu\text{F}$  capacitor is recommended. If there are multiple  $V_{CC}$  terminals then 0.01  $\mu\text{F}$  or 0.022  $\mu\text{F}$  capacitor is recommended for each power terminal. It is acceptable to parallel multiple bypass capacitors to reject different frequencies of noise. 0.1  $\mu\text{F}$  and 1  $\mu\text{F}$  capacitors are commonly used in parallel. The bypass capacitor should be installed as close to the power terminal as possible for best results.

### 9.4 Layout

#### 9.4.1 Layout Guidelines

When using multiple bit logic devices, inputs should not float.

In many cases, functions or parts of functions of digital logic devices are unused, for example, when only two inputs of a triple-input AND gate are used or only 3 of the 4 buffer gates are used. Such input pins should not be left unconnected because the undefined voltages at the outside connections result in undefined operational states. Specified below are the rules that must be observed under all circumstances. All unused inputs of digital logic devices must be connected to a high or low bias to prevent them from floating. The logic level that should be applied to any particular unused input depends on the function of the device. Generally they will be tied to GND or  $V_{CC}$  whichever make more sense or is more convenient. It is generally OK to float outputs unless the part is a transceiver.

#### 9.4.2 Layout Example

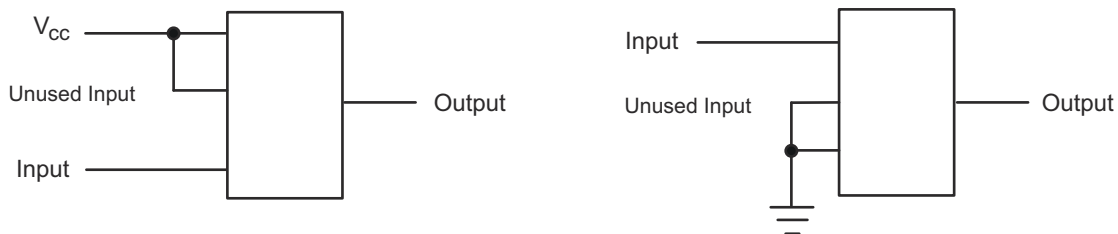

Figure 9-3. Layout Diagram

## 10 Device and Documentation Support

### 10.1 Documentation Support

#### 10.1.1 Related Documentation

The table below lists quick access links. Categories include technical documents, support and community resources, tools and software, and quick access to sample or buy.

**Table 10-1. Related Links**

PARTS	PRODUCT FOLDER	SAMPLE & BUY	TECHNICAL DOCUMENTS	TOOLS & SOFTWARE	SUPPORT & COMMUNITY
SN74LV06A	<a href="#">Click here</a>	<a href="#">Click here</a>	<a href="#">Click here</a>	<a href="#">Click here</a>	<a href="#">Click here</a>

### 10.2 Receiving Notification of Documentation Updates

To receive notification of documentation updates, navigate to the device product folder on [ti.com](http://ti.com). Click on *Subscribe to updates* to register and receive a weekly digest of any product information that has changed. For change details, review the revision history included in any revised document.

### 10.3 Support Resources

[TI E2E™ support forums](#) are an engineer's go-to source for fast, verified answers and design help — straight from the experts. Search existing answers or ask your own question to get the quick design help you need.

Linked content is provided "AS IS" by the respective contributors. They do not constitute TI specifications and do not necessarily reflect TI's views; see TI's [Terms of Use](#).

### 10.4 Trademarks

TI E2E™ is a trademark of Texas Instruments.

All trademarks are the property of their respective owners.

### 10.5 Electrostatic Discharge Caution



This integrated circuit can be damaged by ESD. Texas Instruments recommends that all integrated circuits be handled with appropriate precautions. Failure to observe proper handling and installation procedures can cause damage.

ESD damage can range from subtle performance degradation to complete device failure. Precision integrated circuits may be more susceptible to damage because very small parametric changes could cause the device not to meet its published specifications.

### 10.6 Glossary

[TI Glossary](#) This glossary lists and explains terms, acronyms, and definitions.

## 11 Mechanical, Packaging, and Orderable Information

The following pages include mechanical, packaging, and orderable information. This information is the most current data available for the designated devices. This data is subject to change without notice and revision of this document. For browser-based versions of this data sheet, refer to the left-hand navigation.

**PACKAGING INFORMATION**

Orderable Device	Status (1)	Package Type	Package Drawing	Pins	Package Qty	Eco Plan (2)	Lead finish/ Ball material (6)	MSL Peak Temp (3)	Op Temp (°C)	Device Marking (4/5)	Samples
SN74LV06ADBR	ACTIVE	SSOP	DB	14	2000	RoHS & Green	NIPDAU	Level-1-260C-UNLIM	-40 to 125	LV06A	<a href="#">Samples</a>
SN74LV06ADGVR	ACTIVE	TVSOP	DGV	14	2000	RoHS & Green	NIPDAU	Level-1-260C-UNLIM	-40 to 125	LV06A	<a href="#">Samples</a>
SN74LV06ADR	ACTIVE	SOIC	D	14	2500	RoHS & Green	NIPDAU   SN	Level-1-260C-UNLIM	-40 to 125	LV06A	<a href="#">Samples</a>
SN74LV06ANSR	ACTIVE	SO	NS	14	2000	RoHS & Green	NIPDAU	Level-1-260C-UNLIM	-40 to 125	74LV06A	<a href="#">Samples</a>
SN74LV06APWR	ACTIVE	TSSOP	PW	14	2000	RoHS & Green	NIPDAU	Level-1-260C-UNLIM	-40 to 125	LV06A	<a href="#">Samples</a>

(1) The marketing status values are defined as follows:

**ACTIVE:** Product device recommended for new designs.

**LIFEBUY:** TI has announced that the device will be discontinued, and a lifetime-buy period is in effect.

**NRND:** Not recommended for new designs. Device is in production to support existing customers, but TI does not recommend using this part in a new design.

**PREVIEW:** Device has been announced but is not in production. Samples may or may not be available.

**OBSELETE:** TI has discontinued the production of the device.

(2) **RoHS:** TI defines "RoHS" to mean semiconductor products that are compliant with the current EU RoHS requirements for all 10 RoHS substances, including the requirement that RoHS substance do not exceed 0.1% by weight in homogeneous materials. Where designed to be soldered at high temperatures, "RoHS" products are suitable for use in specified lead-free processes. TI may reference these types of products as "Pb-Free".

**RoHS Exempt:** TI defines "RoHS Exempt" to mean products that contain lead but are compliant with EU RoHS pursuant to a specific EU RoHS exemption.

**Green:** TI defines "Green" to mean the content of Chlorine (Cl) and Bromine (Br) based flame retardants meet JS709B low halogen requirements of <=1000ppm threshold. Antimony trioxide based flame retardants must also meet the <=1000ppm threshold requirement.

(3) MSL, Peak Temp. - The Moisture Sensitivity Level rating according to the JEDEC industry standard classifications, and peak solder temperature.

(4) There may be additional marking, which relates to the logo, the lot trace code information, or the environmental category on the device.

(5) Multiple Device Markings will be inside parentheses. Only one Device Marking contained in parentheses and separated by a "~" will appear on a device. If a line is indented then it is a continuation of the previous line and the two combined represent the entire Device Marking for that device.

(6) Lead finish/Ball material - Orderable Devices may have multiple material finish options. Finish options are separated by a vertical ruled line. Lead finish/Ball material values may wrap to two lines if the finish value exceeds the maximum column width.

**Important Information and Disclaimer:** The information provided on this page represents TI's knowledge and belief as of the date that it is provided. TI bases its knowledge and belief on information provided by third parties, and makes no representation or warranty as to the accuracy of such information. Efforts are underway to better integrate information from third parties. TI has taken and continues to take reasonable steps to provide representative and accurate information but may not have conducted destructive testing or chemical analysis on incoming materials and chemicals. TI and TI suppliers consider certain information to be proprietary, and thus CAS numbers and other limited information may not be available for release.

In no event shall TI's liability arising out of such information exceed the total purchase price of the TI part(s) at issue in this document sold by TI to Customer on an annual basis.

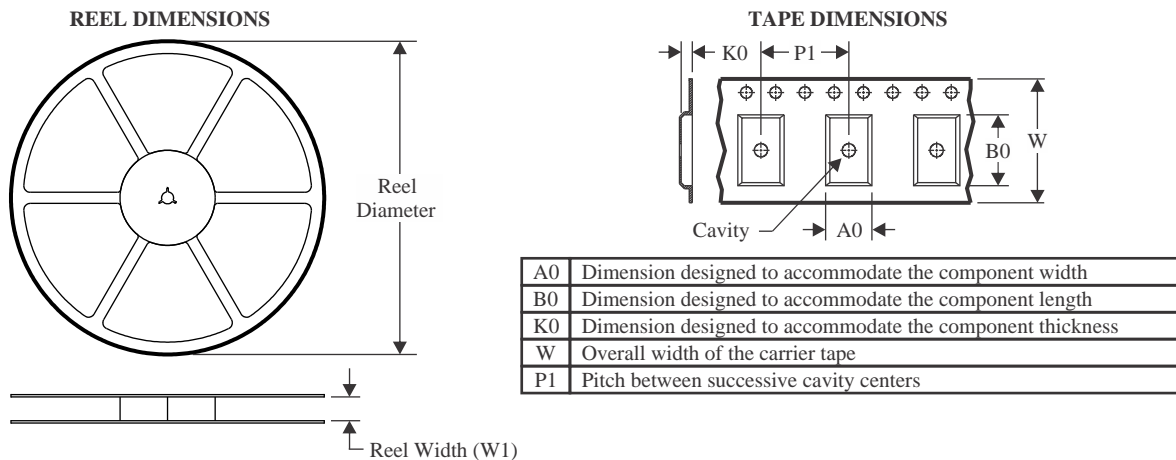
**TAPE AND REEL INFORMATION**

**QUADRANT ASSIGNMENTS FOR PIN 1 ORIENTATION IN TAPE**

\*All dimensions are nominal

Device	Package Type	Package Drawing	Pins	SPQ	Reel Diameter (mm)	Reel Width W1 (mm)	A0 (mm)	B0 (mm)	K0 (mm)	P1 (mm)	W (mm)	Pin1 Quadrant
SN74LV06ADBR	SSOP	DB	14	2000	330.0	16.4	8.35	6.6	2.4	12.0	16.0	Q1
SN74LV06ADGVR	TVSOP	DGV	14	2000	330.0	12.4	6.8	4.0	1.6	8.0	12.0	Q1
SN74LV06ADR	SOIC	D	14	2500	330.0	16.4	6.6	9.3	2.1	8.0	16.0	Q1
SN74LV06ADR	SOIC	D	14	2500	330.0	16.4	6.5	9.0	2.1	8.0	16.0	Q1
SN74LV06ADR	SOIC	D	14	2500	330.0	16.4	6.5	9.0	2.1	8.0	16.0	Q1
SN74LV06ANSR	SO	NS	14	2000	330.0	16.4	8.45	10.55	2.5	12.0	16.2	Q1
SN74LV06ANSR	SO	NS	14	2000	330.0	16.4	8.2	10.5	2.5	12.0	16.0	Q1
SN74LV06APWR	TSSOP	PW	14	2000	330.0	12.4	6.9	5.6	1.6	8.0	12.0	Q1
SN74LV06APWR	TSSOP	PW	14	2000	330.0	12.4	6.9	5.6	1.6	8.0	12.0	Q1

**TAPE AND REEL BOX DIMENSIONS**

\*All dimensions are nominal

Device	Package Type	Package Drawing	Pins	SPQ	Length (mm)	Width (mm)	Height (mm)
SN74LV06ADBR	SSOP	DB	14	2000	356.0	356.0	35.0
SN74LV06ADGVR	TVSOP	DGV	14	2000	356.0	356.0	35.0
SN74LV06ADR	SOIC	D	14	2500	366.0	364.0	50.0
SN74LV06ADR	SOIC	D	14	2500	356.0	356.0	35.0
SN74LV06ADR	SOIC	D	14	2500	356.0	356.0	35.0
SN74LV06ANSR	SO	NS	14	2000	356.0	356.0	35.0
SN74LV06ANSR	SO	NS	14	2000	356.0	356.0	35.0
SN74LV06APWR	TSSOP	PW	14	2000	353.0	353.0	32.0
SN74LV06APWR	TSSOP	PW	14	2000	356.0	356.0	35.0

## MECHANICAL DATA

**NS (R-PDSO-G\*\*)**

**PLASTIC SMALL-OUTLINE PACKAGE**

**14-PINS SHOWN**



- NOTES:
- A. All linear dimensions are in millimeters.
  - B. This drawing is subject to change without notice.
  - C. Body dimensions do not include mold flash or protrusion, not to exceed 0,15.

DGV (R-PDSO-G\*\*)

PLASTIC SMALL-OUTLINE

24 PINS SHOWN



4073251/E 08/00

- NOTES: A. All linear dimensions are in millimeters.  
 B. This drawing is subject to change without notice.  
 C. Body dimensions do not include mold flash or protrusion, not to exceed 0,15 per side.  
 D. Falls within JEDEC: 24/48 Pins – MO-153  
 14/16/20/56 Pins – MO-194



PW (R-PDSO-G14)

PLASTIC SMALL OUTLINE

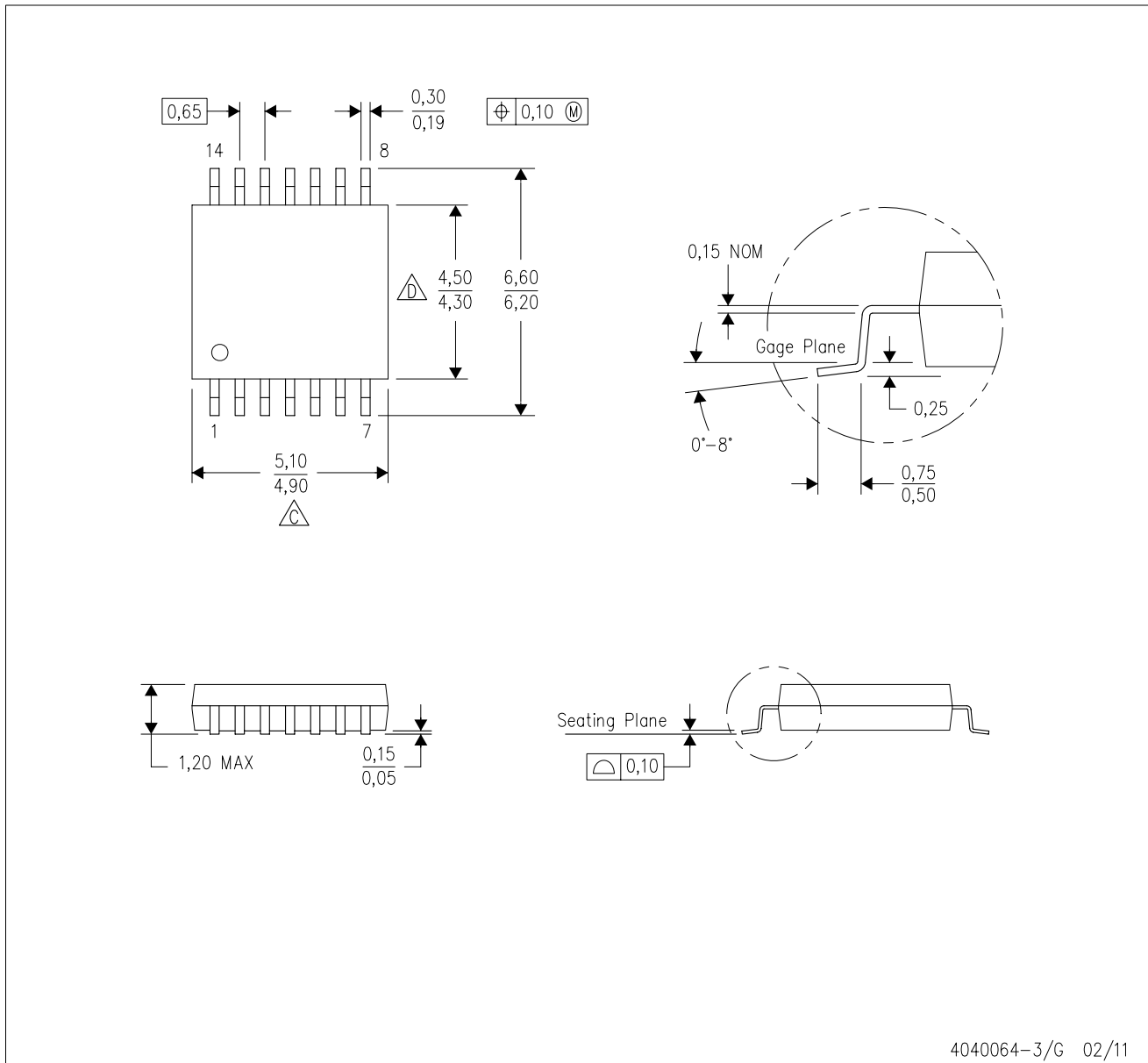

- NOTES:
- A. All linear dimensions are in millimeters. Dimensioning and tolerancing per ASME Y14.5M-1994.
  - B. This drawing is subject to change without notice.
  - C. Body length does not include mold flash, protrusions, or gate burrs. Mold flash, protrusions, or gate burrs shall not exceed 0,15 each side.
  - D. Body width does not include interlead flash. Interlead flash shall not exceed 0,25 each side.
  - E. Falls within JEDEC MO-153

DB (R-PDSO-G\*\*)

PLASTIC SMALL-OUTLINE

28 PINS SHOWN



- NOTES: A. All linear dimensions are in millimeters.  
 B. This drawing is subject to change without notice.  
 C. Body dimensions do not include mold flash or protrusion not to exceed 0,15.  
 D. Falls within JEDEC MO-150

## IMPORTANT NOTICE AND DISCLAIMER

TI PROVIDES TECHNICAL AND RELIABILITY DATA (INCLUDING DATA SHEETS), DESIGN RESOURCES (INCLUDING REFERENCE DESIGNS), APPLICATION OR OTHER DESIGN ADVICE, WEB TOOLS, SAFETY INFORMATION, AND OTHER RESOURCES "AS IS" AND WITH ALL FAULTS, AND DISCLAIMS ALL WARRANTIES, EXPRESS AND IMPLIED, INCLUDING WITHOUT LIMITATION ANY IMPLIED WARRANTIES OF MERCHANTABILITY, FITNESS FOR A PARTICULAR PURPOSE OR NON-INFRINGEMENT OF THIRD PARTY INTELLECTUAL PROPERTY RIGHTS.

These resources are intended for skilled developers designing with TI products. You are solely responsible for (1) selecting the appropriate TI products for your application, (2) designing, validating and testing your application, and (3) ensuring your application meets applicable standards, and any other safety, security, regulatory or other requirements.

These resources are subject to change without notice. TI grants you permission to use these resources only for development of an application that uses the TI products described in the resource. Other reproduction and display of these resources is prohibited. No license is granted to any other TI intellectual property right or to any third party intellectual property right. TI disclaims responsibility for, and you will fully indemnify TI and its representatives against, any claims, damages, costs, losses, and liabilities arising out of your use of these resources.

TI's products are provided subject to [TI's Terms of Sale](#) or other applicable terms available either on [ti.com](https://www.ti.com) or provided in conjunction with such TI products. TI's provision of these resources does not expand or otherwise alter TI's applicable warranties or warranty disclaimers for TI products.

TI objects to and rejects any additional or different terms you may have proposed.

Mailing Address: Texas Instruments, Post Office Box 655303, Dallas, Texas 75265  
Copyright © 2024, Texas Instruments Incorporated

## Looking for pricing, stock, or lifecycle information?

Click below to explore more details on WIN SOURCE:

 [View SN74LV06APWR on WIN SOURCE](#)

 [Texas Instruments](#) Information

## Optimize Your Supply Chain with WIN SOURCE Solutions

-  Global Sourcing Solution
-  Obsolete Management
-  Cost Control Management
-  Shortage Management
-  Alternative Solution
-  Excess Inventory Management