



**THE DATASHEET OF  
SN74LS374DW**



# SN54LS373, SN54LS374, SN54S373, SN54S374, SN74LS373, SN74LS374, SN74S373, SN74S374

## OCTAL D-TYPE TRANSPARENT LATCHES AND EDGE-TRIGGERED FLIP-FLOPS

SDLS165B – OCTOBER 1975 – REVISED AUGUST 2002

- Choice of Eight Latches or Eight D-Type Flip-Flops in a Single Package
- 3-State Bus-Driving Outputs
- Full Parallel Access for Loading
- Buffered Control Inputs
- Clock-Enable Input Has Hysteresis to Improve Noise Rejection ('S373 and 'S374)
- P-N-P Inputs Reduce DC Loading on Data Lines ('S373 and 'S374)

### description

These 8-bit registers feature 3-state outputs designed specifically for driving highly capacitive or relatively low-impedance loads. The high-impedance 3-state and increased high-logic-level drive provide these registers with the capability of being connected directly to and driving the bus lines in a bus-organized system without need for interface or pullup components. These devices are particularly attractive for implementing buffer registers, I/O ports, bidirectional bus drivers, and working registers.

The eight latches of the 'LS373 and 'S373 are transparent D-type latches, meaning that while the enable (C or CLK) input is high, the Q outputs follow the data (D) inputs. When C or CLK is taken low, the output is latched at the level of the data that was set up.

The eight flip-flops of the 'LS374 and 'S374 are edge-triggered D-type flip-flops. On the positive transition of the clock, the Q outputs are set to the logic states that were set up at the D inputs.

Schmitt-trigger buffered inputs at the enable/clock lines of the 'S373 and 'S374 devices simplify system design as ac and dc noise rejection is improved by typically 400 mV due to the input hysteresis. A buffered output-control ( $\overline{OC}$ ) input can be used to place the eight outputs in either a normal logic state (high or low logic levels) or the high-impedance state. In the high-impedance state, the outputs neither load nor drive the bus lines significantly.

$\overline{OC}$  does not affect the internal operation of the latches or flip-flops. That is, the old data can be retained or new data can be entered, even while the outputs are off.

SN54LS373, SN54LS374, SN54S373,  
SN54S374 . . . J OR W PACKAGE  
SN74LS373, SN74S374 . . . DW, N, OR NS PACKAGE  
SN74LS374 . . . DB, DW, N, OR NS PACKAGE  
SN74S373 . . . DW OR N PACKAGE  
(TOP VIEW)

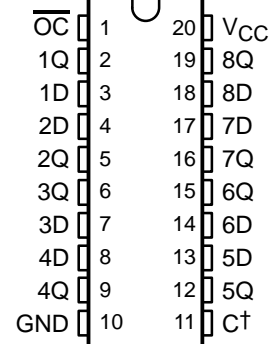

† C for 'LS373 and 'S373; CLK for 'LS374 and 'S374.

SN54LS373, SN54LS374, SN54S373,  
SN54S374 . . . FK PACKAGE  
(TOP VIEW)

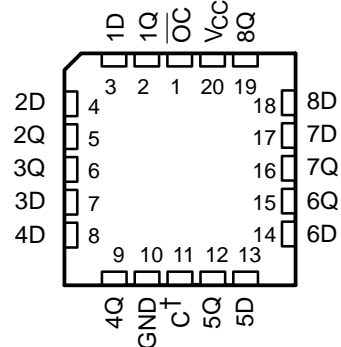

† C for 'LS373 and 'S373; CLK for 'LS374 and 'S374.



Please be aware that an important notice concerning availability, standard warranty, and use in critical applications of Texas Instruments semiconductor products and disclaimers thereto appears at the end of this data sheet.

PRODUCTION DATA information is current as of publication date. Products conform to specifications per the terms of Texas Instruments standard warranty. Production processing does not necessarily include testing of all parameters.



POST OFFICE BOX 655303 • DALLAS, TEXAS 75265

Copyright © 2002, Texas Instruments Incorporated  
On products compliant to MIL-PRF-38535, all parameters are tested unless otherwise noted. On all other products, production processing does not necessarily include testing of all parameters.

**SN54LS373, SN54LS374, SN54S373, SN54S374,  
SN74LS373, SN74LS374, SN74S373, SN74S374  
OCTAL D-TYPE TRANSPARENT LATCHES AND EDGE-TRIGGERED FLIP-FLOPS**

SDLS165B – OCTOBER 1975 – REVISED AUGUST 2002

**ORDERING INFORMATION**

<b>T<sub>A</sub></b>	<b>PACKAGE†</b>		<b>ORDERABLE PART NUMBER</b>	<b>TOP-SIDE MARKING</b>
0°C to 70°C	PDIP – N	Tube	SN74LS373N	SN74LS373N
		Tube	SN74LS374N	SN74LS374N
		Tube	SN74S373N	SN74S373N
		Tube	SN74S374N	SN74S374N
	SOIC – DW	Tube	SN74LS373DW	LS373
		Tape and reel	SN74LS373DWR	
		Tube	SN74LS374DW	LS374
		Tape and reel	SN74LS374DWR	
		Tube	SN74S373DW	S373
		Tape and reel	SN74S373DWR	
		Tube	SN74S374DW	S374
		Tape and reel	SN74S374DWR	
	SOP – NS	Tape and reel	SN74LS373NSR	74LS373
		Tape and reel	SN74LS374NSR	74LS374
		Tape and reel	SN74S374NSR	74S374
	SSOP – DB	Tape and reel	SN74LS374DBR	LS374A
–55°C to 125°C	CDIP – J	Tube	SN54LS373J	SN54LS373J
		Tube	SNJ54LS373J	SNJ54LS373J
		Tube	SN54LS374J	SN54LS374J
		Tube	SNJ54LS374J	SNJ54LS374J
		Tube	SN54S373J	SN54S373J
		Tube	SNJ54S373J	SNJ54S373J
		Tube	SN54S374J	SN54S374J
		Tube	SNJ54S374J	SNJ54S374J
	CFP – W	Tube	SNJ54LS373W	SNJ54LS373W
		Tube	SNJ54LS374W	SNJ54LS374W
		Tube	SNJ54S374W	SNJ54S374W
	LCCC – FK	Tube	SNJ54LS373FK	SNJ54LS373FK
		Tube	SNJ54LS374FK	SNJ54LS374FK
		Tube	SNJ54S373FK	SNJ54S373FK
		Tube	SNJ54S374FK	SNJ54S374FK

† Package drawings, standard packing quantities, thermal data, symbolization, and PCB design guidelines are available at [www.ti.com/sc/package](http://www.ti.com/sc/package).



**SN54LS373, SN54LS374, SN54S373, SN54S374,  
SN74LS373, SN74LS374, SN74S373, SN74S374**  
**OCTAL D-TYPE TRANSPARENT LATCHES AND EDGE-TRIGGERED FLIP-FLOPS**

SDLS165B – OCTOBER 1975 – REVISED AUGUST 2002

**Function Tables**

'LS373, 'S373  
(each latch)

INPUTS			OUTPUT Q
$\overline{OC}$	C	D	
L	H	H	H
L	H	L	L
L	L	X	Q <sub>0</sub>
H	X	X	Z

'LS374, 'S374  
(each latch)

INPUTS			OUTPUT Q
$\overline{OC}$	CLK	D	
L	↑	H	H
L	↑	L	L
L	L	X	Q <sub>0</sub>
H	X	X	Z

**SN54LS373, SN54LS374, SN54S373, SN54S374,  
SN74LS373, SN74LS374, SN74S373, SN74S374**  
**OCTAL D-TYPE TRANSPARENT LATCHES AND EDGE-TRIGGERED FLIP-FLOPS**

SDLS165B – OCTOBER 1975 – REVISED AUGUST 2002

**logic diagrams (positive logic)**

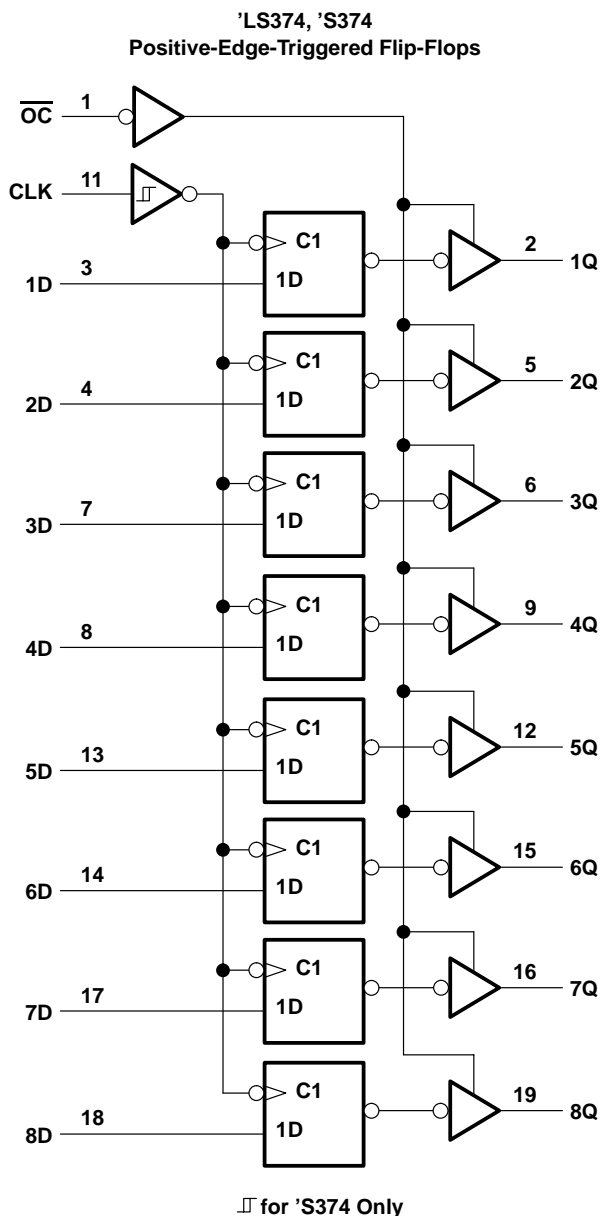
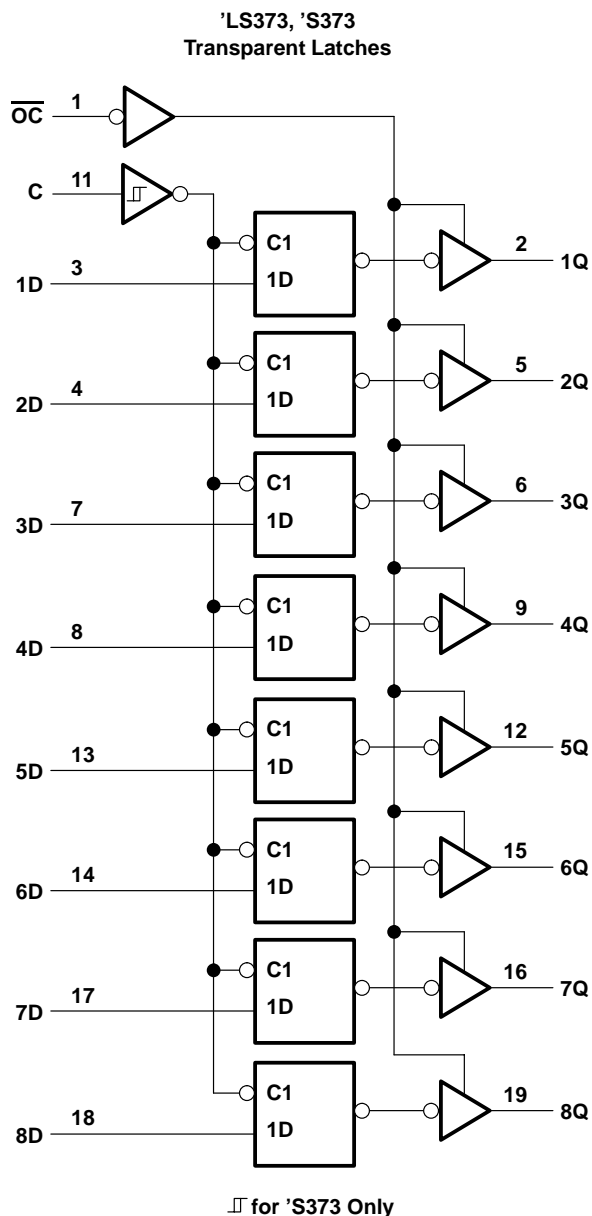

Pin numbers shown are for DB, DW, J, N, NS, and W packages.



POST OFFICE BOX 655303 • DALLAS, TEXAS 75265

**SN54LS373, SN54LS374, SN54S373, SN54S374,  
SN74LS373, SN74LS374, SN74S373, SN74S374**

SDLS165B – OCTOBER 1975 – REVISED AUGUST 2002

**schematic of inputs and outputs**

**'LS373**

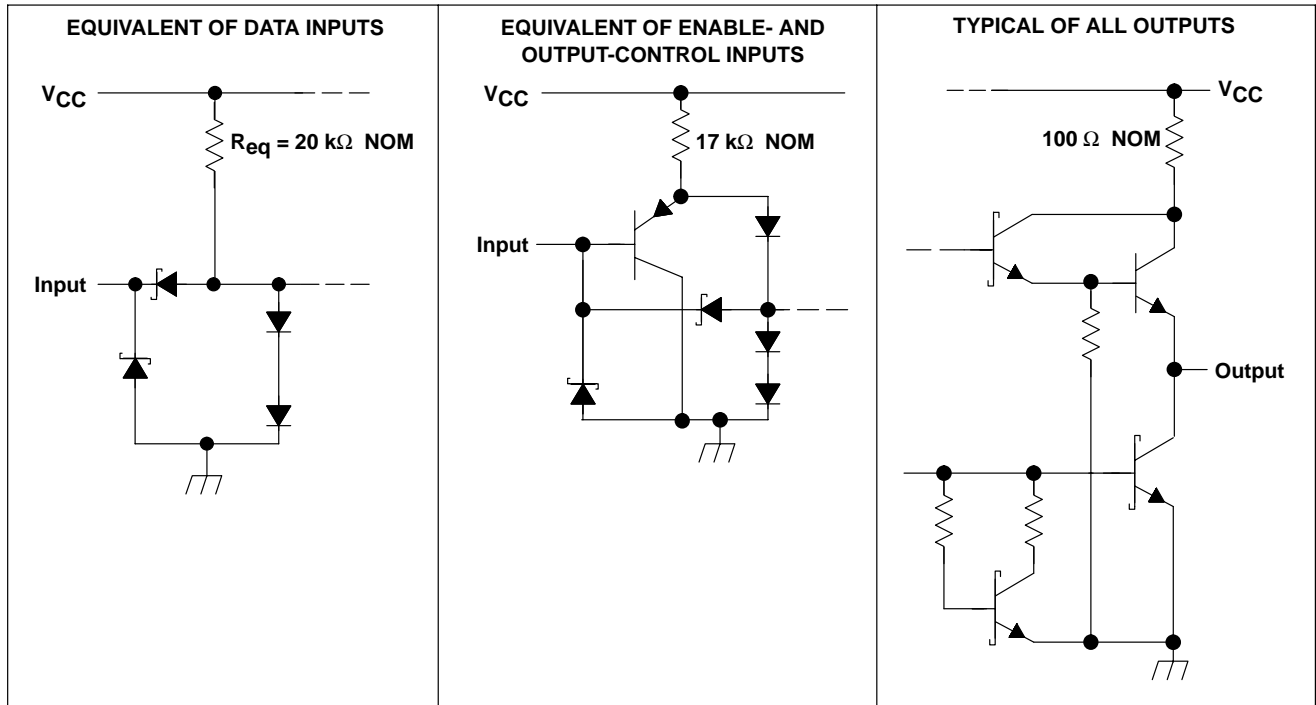

**'LS374**

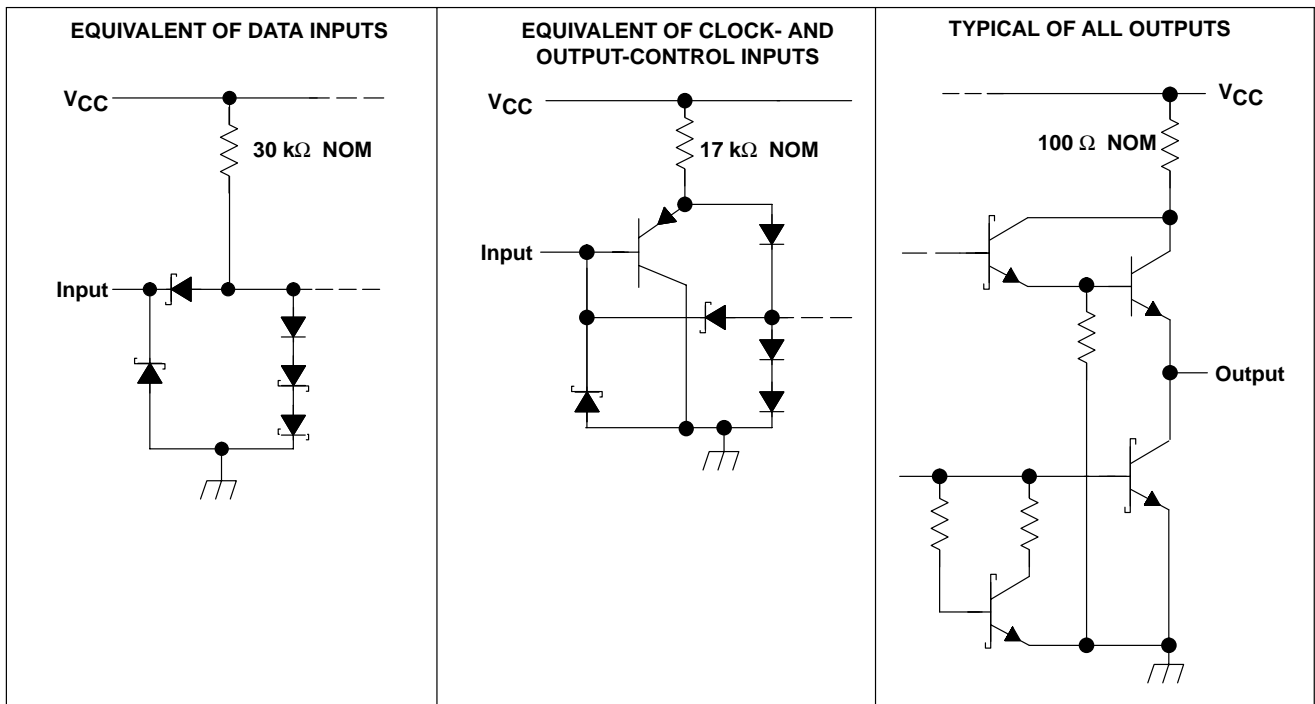

**SN54LS373, SN54LS374, SN54S373, SN54S374,  
SN74LS373, SN74LS374, SN74S373, SN74S374  
OCTAL D-TYPE TRANSPARENT LATCHES AND EDGE-TRIGGERED FLIP-FLOPS**

SDLS165B – OCTOBER 1975 – REVISED AUGUST 2002

**absolute maximum ratings over operating free-air temperature range (unless otherwise noted)†  
(‘LS devices)**

Supply voltage, $V_{CC}$ (see Note 1)	7 V
Input voltage, $V_I$	7 V
Off-state output voltage	5.5 V
Package thermal impedance, $\theta_{JA}$ (see Note 2): DB package	70°C/W
DW package	58°C/W
N package	69°C/W
NS package	60°C/W
Storage temperature range, $T_{stg}$	-65°C to 150°C

† Stresses beyond those listed under “absolute maximum ratings” may cause permanent damage to the device. These are stress ratings only, and functional operation of the device at these or any other conditions beyond those indicated under “recommended operating conditions” is not implied. Exposure to absolute-maximum-rated conditions for extended periods may affect device reliability.

- NOTES: 1. Voltage values are with respect to network ground terminal.  
2. The package thermal impedance is calculated in accordance with JESD 51-7.

**recommended operating conditions**

		SN54LS'			SN74LS'			UNIT		
		MIN	NOM	MAX	MIN	NOM	MAX			
$V_{CC}$	Supply voltage	4.5	5	5	4.75	5	5.25	V		
$V_{OH}$	High-level output voltage			5.5			5.5	V		
$I_{OH}$	High-level output current			-1			-2.6	mA		
$I_{OL}$	Low-level output current			12			24	mA		
$t_w$	Pulse duration	CLK high		15		15		ns		
		CLK low		15		15				
$t_{su}$	Data setup time	'LS373		5↓		5↓		ns		
		'LS374		20↑		20↑				
$t_h$	Data hold time	'LS373		20↓		20↓		ns		
		'LS374‡		5↑		0↑				
$T_A$	Operating free-air temperature			-55		125		0	70	°C

‡ The  $t_h$  specification applies only for data frequency below 10 MHz. Designs above 10 MHz should use a minimum of 5 ns (commercial only).



**SN54LS373, SN54LS374, SN54S373, SN54S374,  
SN74LS373, SN74LS374, SN74S373, SN74S374**  
**OCTAL D-TYPE TRANSPARENT LATCHES AND EDGE-TRIGGERED FLIP-FLOPS**

SDLS165B – OCTOBER 1975 – REVISED AUGUST 2002

**electrical characteristics over recommended operating free-air temperature range (unless otherwise noted)**

PARAMETER	TEST CONDITIONS†	SN54LS'			SN74LS'			UNIT	
		MIN	TYP‡	MAX	MIN	TYP‡	MAX		
V <sub>IH</sub> High-level input voltage		2			2			V	
V <sub>IL</sub> Low-level input voltage					0.7			V	
V <sub>IK</sub> Input clamp voltage	V <sub>CC</sub> = MIN, I <sub>I</sub> = -18 mA				-1.5			V	
V <sub>OH</sub> High-level output voltage	V <sub>CC</sub> = MIN, V <sub>IH</sub> = 2 V, V <sub>IL</sub> = V <sub>IL</sub> max, I <sub>OH</sub> = MAX	2.4	3.4		2.4	3.1		V	
V <sub>OL</sub> Low-level output voltage	V <sub>CC</sub> = MIN, V <sub>IH</sub> = 2 V, V <sub>IL</sub> = V <sub>IL</sub> max	I <sub>OL</sub> = 12 mA			0.25	0.4	0.25	0.4	V
		I <sub>OL</sub> = 24 mA					0.35	0.5	
I <sub>OZH</sub> Off-state output current, high-level voltage applied	V <sub>CC</sub> = MAX, V <sub>O</sub> = 2.7 V, V <sub>IH</sub> = 2 V				20			μA	
I <sub>OZL</sub> Off-state output current, low-level voltage applied	V <sub>CC</sub> = MAX, V <sub>O</sub> = 0.4 V, V <sub>IH</sub> = 2 V				-20			μA	
I <sub>I</sub> Input current at maximum input voltage	V <sub>CC</sub> = MAX, V <sub>I</sub> = 7 V				0.1			mA	
I <sub>IH</sub> High-level input current	V <sub>CC</sub> = MAX, V <sub>I</sub> = 2.7 V				20			μA	
I <sub>IL</sub> Low-level input current	V <sub>CC</sub> = MAX, V <sub>I</sub> = 0.4 V				-0.4			mA	
I <sub>OS</sub> Short-circuit output current§	V <sub>CC</sub> = MAX				-30	-130	-30	-130	mA
I <sub>CC</sub> Supply current	V <sub>CC</sub> = MAX, Output control at 4.5 V	'LS373			24	40	24	40	mA
		'LS374			27	40	27	40	

† For conditions shown as MIN or MAX, use the appropriate value specified under recommended operating conditions.

‡ All typical values are at V<sub>CC</sub> = 5 V, T<sub>A</sub> = 25°C.

§ Not more than one output should be shorted at a time and duration of the short circuit should not exceed one second.

**switching characteristics, V<sub>CC</sub> = 5 V, T<sub>A</sub> = 25°C (see Figure 1)**

PARAMETER	FROM (INPUT)	TO (OUTPUT)	TEST CONDITIONS	'LS373			'LS374			UNIT
				MIN	TYP	MAX	MIN	TYP	MAX	
f <sub>max</sub>			R <sub>L</sub> = 667 Ω, C <sub>L</sub> = 45 pF, See Note 3				35	50		MHz
t <sub>PLH</sub>	Data	Any Q	R <sub>L</sub> = 667 Ω, C <sub>L</sub> = 45 pF, See Note 3	12 18						ns
t <sub>PHL</sub>				12 18						
t <sub>PLH</sub>	C or CLK	Any Q	R <sub>L</sub> = 667 Ω, C <sub>L</sub> = 45 pF, See Note 3	20 30			15 28			ns
t <sub>PHL</sub>				18 30			19 28			
t <sub>PZH</sub>	$\overline{OC}$	Any Q	R <sub>L</sub> = 667 Ω, C <sub>L</sub> = 45 pF, See Note 3	15 28			20 26			ns
t <sub>PZL</sub>				25 36			21 28			
t <sub>PHZ</sub>	$\overline{OC}$	Any Q	R <sub>L</sub> = 667 Ω, C <sub>L</sub> = 5 pF	15 25			15 28			ns
t <sub>PLZ</sub>				12 20			12 20			

NOTE 3: Maximum clock frequency is tested with all outputs loaded.

f<sub>max</sub> = maximum clock frequency

t<sub>PLH</sub> = propagation delay time, low-to-high-level output

t<sub>PHL</sub> = propagation delay time, high-to-low-level output

t<sub>PZH</sub> = output enable time to high level

t<sub>PZL</sub> = output enable time to low level

t<sub>PHZ</sub> = output disable time from high level

t<sub>PLZ</sub> = output disable time from low level



**SN54LS373, SN54LS374, SN54S373, SN54S374,  
SN74LS373, SN74LS374, SN74S373, SN74S374  
OCTAL D-TYPE TRANSPARENT LATCHES AND EDGE-TRIGGERED FLIP-FLOPS**

SDLS165B – OCTOBER 1975 – REVISED AUGUST 2002

**schematic of inputs and outputs**

'S373 and 'S374

'S373 and 'S374

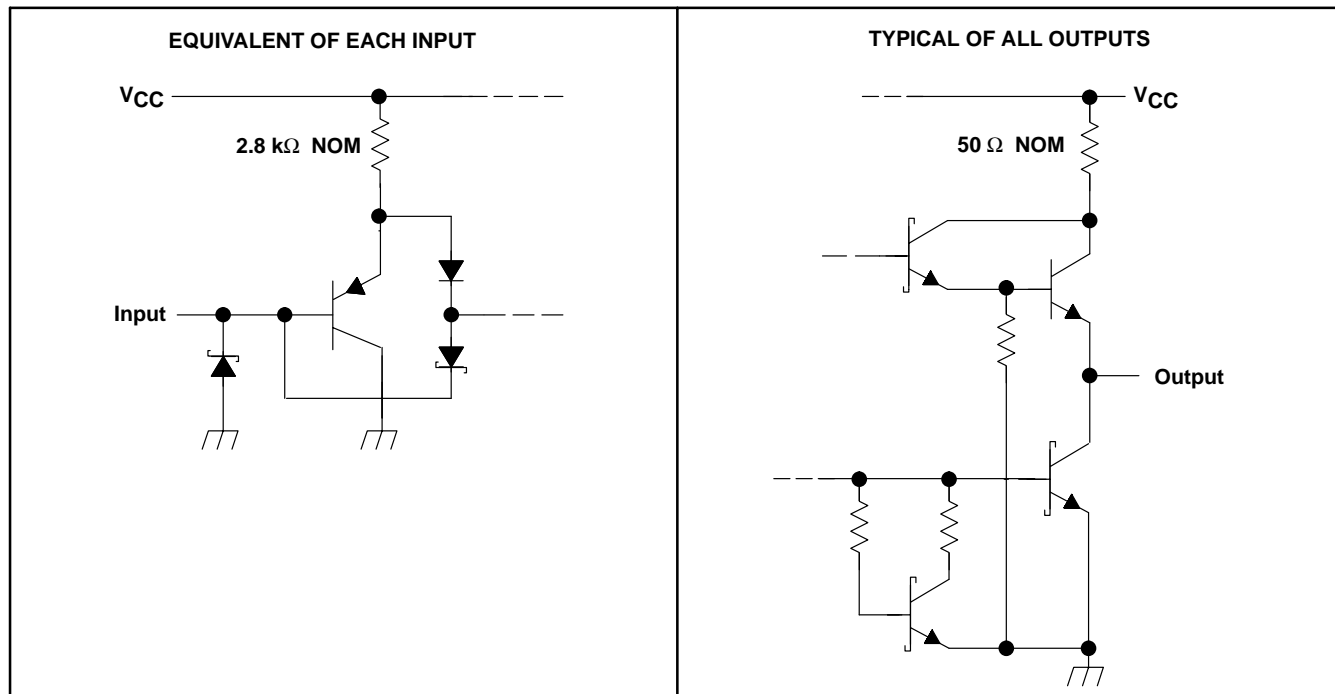

**SN54LS373, SN54LS374, SN54S373, SN54S374,  
SN74LS373, SN74LS374, SN74S373, SN74S374**  
**OCTAL D-TYPE TRANSPARENT LATCHES AND EDGE-TRIGGERED FLIP-FLOPS**

SDLS165B – OCTOBER 1975 – REVISED AUGUST 2002

**absolute maximum ratings over operating free-air temperature range (unless otherwise noted)†  
(‘S devices)**

Supply voltage, $V_{CC}$ (see Note 1) .....	7 V
Input voltage, $V_I$ .....	5.5 V
Off-state output voltage .....	5.5 V
Package thermal impedance, $\theta_{JA}$ (see Note 2): DW package .....	58°C/W
N package .....	69°C/W
NS package .....	60°C/W
Storage temperature range, $T_{stg}$ .....	–65°C to 150°C

† Stresses beyond those listed under “absolute maximum ratings” may cause permanent damage to the device. These are stress ratings only, and functional operation of the device at these or any other conditions beyond those indicated under “recommended operating conditions” is not implied. Exposure to absolute-maximum-rated conditions for extended periods may affect device reliability.

- NOTES: 1. Voltage values are with respect to network ground terminal.  
2. The package thermal impedance is calculated in accordance with JESD 51-7.

**recommended operating conditions**

		SN54S'			SN74S'			UNIT
		MIN	NOM	MAX	MIN	NOM	MAX	
$V_{CC}$	Supply voltage	4.5	5	5.5	4.75	5	5.25	V
$V_{OH}$	High-level output voltage			5.5			5.5	V
$I_{OH}$	High-level output current			–2			–6.5	mA
$t_w$	Pulse duration, clock/enable	High	6		6			ns
		Low	7.3		7.3			
$t_{su}$	Data setup time	'S373	0↓		0↓			ns
		'S374	5↑		5↑			
$t_h$	Data hold time	'S373	10↓		10↓			ns
		'S374	2↑		2↑			
$T_A$	Operating free-air temperature	–55		125	0		70	°C



**SN54LS373, SN54LS374, SN54S373, SN54S374,  
SN74LS373, SN74LS374, SN74S373, SN74S374  
OCTAL D-TYPE TRANSPARENT LATCHES AND EDGE-TRIGGERED FLIP-FLOPS**

SDLS165B – OCTOBER 1975 – REVISED AUGUST 2002

**electrical characteristics over recommended operating free-air temperature range (unless otherwise noted) (SN54S373, SN54S374, SN74S373, SN74S374)**

PARAMETER		TEST CONDITIONS†				MIN	TYP‡	MAX	UNIT
V <sub>IH</sub>						2			V
V <sub>IL</sub>								0.8	V
V <sub>IK</sub>		V <sub>CC</sub> = MIN, I <sub>I</sub> = -18 mA						-1.2	V
V <sub>OH</sub>	SN54S'	V <sub>CC</sub> = MIN, V <sub>IH</sub> = 2 V, V <sub>IL</sub> = 0.8 V, I <sub>OH</sub> = MAX				2.4	3.4		V
	SN74S'					2.4	3.1		
V <sub>OL</sub>		V <sub>CC</sub> = MIN, V <sub>IH</sub> = 2 V, V <sub>IL</sub> = 0.8 V, I <sub>OL</sub> = 20 mA						0.5	V
I <sub>OZH</sub>		V <sub>CC</sub> = MAX, V <sub>IH</sub> = 2 V, V <sub>O</sub> = 2.4 V						50	μA
I <sub>OZL</sub>		V <sub>CC</sub> = MAX, V <sub>IH</sub> = 2 V, V <sub>O</sub> = 0.5 V						-50	μA
I <sub>I</sub>		V <sub>CC</sub> = MAX, V <sub>I</sub> = 5.5 V						1	mA
I <sub>IH</sub>		V <sub>CC</sub> = MAX, V <sub>I</sub> = 2.7 V						50	μA
I <sub>IL</sub>		V <sub>CC</sub> = MAX, V <sub>I</sub> = 0.5 V						-250	μA
I <sub>OS</sub> §		V <sub>CC</sub> = MAX				-40		-100	mA
I <sub>CC</sub>	V <sub>CC</sub> = MAX	'S373	Outputs high				160	mA	
			Outputs low				160		
			Outputs disabled				190		
		'S374	Outputs high				110		
			Outputs low				140		
			Outputs disabled				160		
			CLK and $\overline{OC}$ at 4 V, D inputs at 0 V				180		

† For conditions shown as MIN or MAX, use the appropriate value specified under recommended operating conditions.

‡ All typical values are at V<sub>CC</sub> = 5 V, T<sub>A</sub> = 25°C.

§ Not more than one output should be shorted at a time and duration of the short circuit should not exceed one second.

**switching characteristics, V<sub>CC</sub> = 5 V, T<sub>A</sub> = 25°C (see Figure 2)**

PARAMETER	FROM (INPUT)	TO (OUTPUT)	TEST CONDITIONS	'S373			'S374			UNIT
				MIN	TYP	MAX	MIN	TYP	MAX	
f <sub>max</sub>			R <sub>L</sub> = 280 Ω, C <sub>L</sub> = 15 pF, See Note 3				75	100		MHz
t <sub>PLH</sub>	Data	Any Q	R <sub>L</sub> = 280 Ω, C <sub>L</sub> = 15 pF, See Note 3	7	12					ns
t <sub>PHL</sub>				7	12					
t <sub>PLH</sub>	C or CLK	Any Q	R <sub>L</sub> = 280 Ω, C <sub>L</sub> = 15 pF, See Note 3	7	14		8	15		ns
t <sub>PHL</sub>				12	18		11	17		
t <sub>PZH</sub>	$\overline{OC}$	Any Q	R <sub>L</sub> = 280 Ω, C <sub>L</sub> = 15 pF, See Note 3	8	15		8	15		ns
t <sub>PZL</sub>				11	18		11	18		
t <sub>PHZ</sub>	$\overline{OC}$	Any Q	R <sub>L</sub> = 280 Ω, C <sub>L</sub> = 5 pF	6	9		5	9		ns
t <sub>PLZ</sub>				8	12		7	12		

NOTE 3. Maximum clock frequency is tested with all outputs loaded.

f<sub>max</sub> = maximum clock frequency

t<sub>PLH</sub> = propagation delay time, low-to-high-level output

t<sub>PHL</sub> = propagation delay time, high-to-low-level output

t<sub>PZH</sub> = output enable time to high level

t<sub>PZL</sub> = output enable time to low level

t<sub>PHZ</sub> = output disable time from high level

t<sub>PLZ</sub> = output disable time from low level



**SN54LS373, SN54LS374, SN54S373, SN54S374,  
SN74LS373, SN74LS374, SN74S373, SN74S374**

SDLS165B – OCTOBER 1975 – REVISED AUGUST 2002

**PARAMETER MEASUREMENT INFORMATION  
SERIES 54LS/74LS DEVICES**

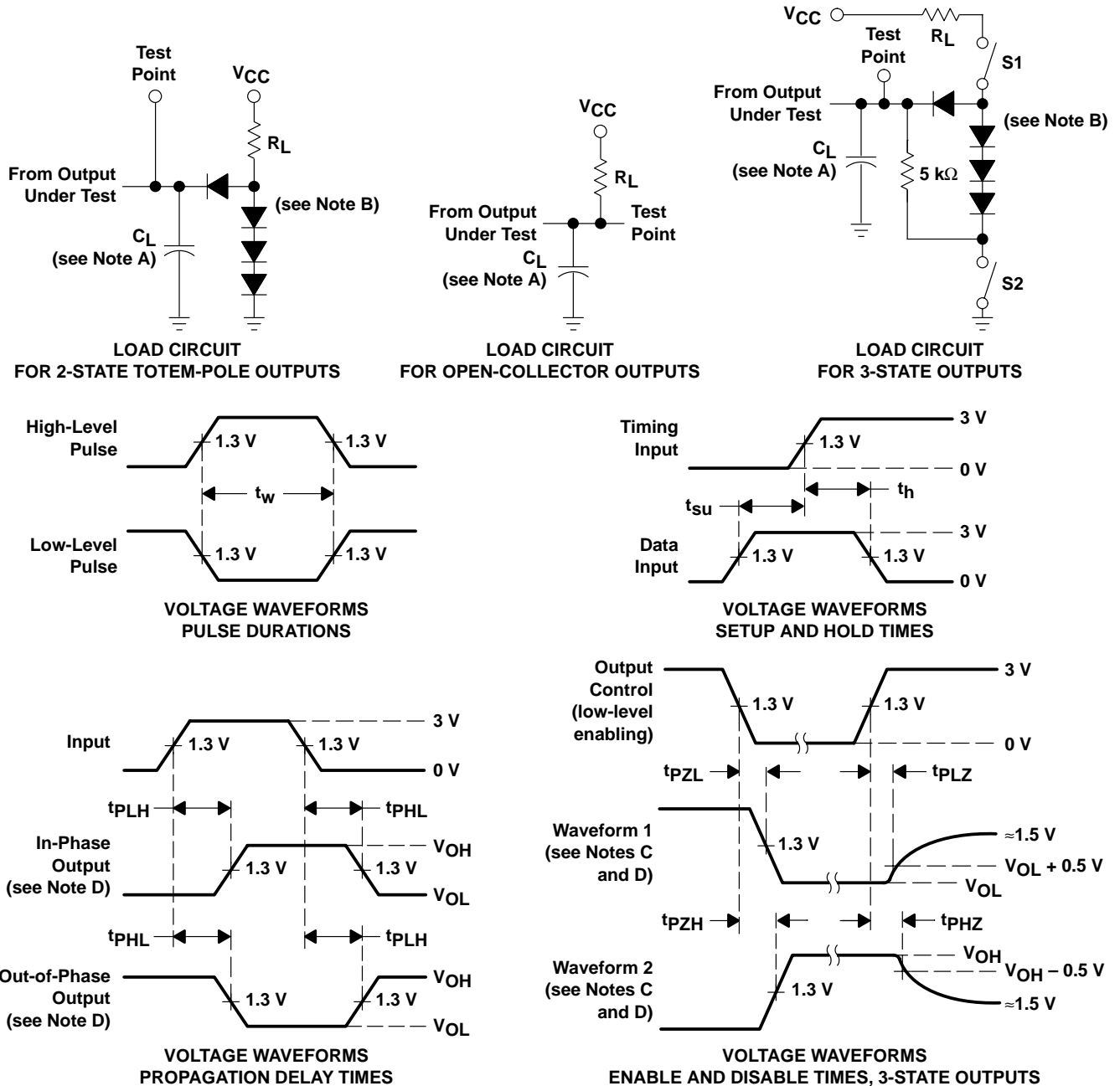

- NOTES: A.  $C_L$  includes probe and jig capacitance.  
 B. All diodes are 1N3064 or equivalent.  
 C. Waveform 1 is for an output with internal conditions such that the output is low except when disabled by the output control. Waveform 2 is for an output with internal conditions such that the output is high except when disabled by the output control.  
 D. S1 and S2 are closed for  $t_{PLH}$ ,  $t_{PHL}$ ,  $t_{PHZ}$ , and  $t_{PLZ}$ ; S1 is open and S2 is closed for  $t_{PZH}$ ; S1 is closed and S2 is open for  $t_{PZL}$ .  
 E. Phase relationships between inputs and outputs have been chosen arbitrarily for these examples.  
 F. All input pulses are supplied by generators having the following characteristics:  $PRR \leq 1$  MHz,  $Z_O \approx 50 \Omega$ ,  $t_r \leq 1.5$  ns,  $t_f \leq 2.6$  ns.  
 G. The outputs are measured one at a time with one input transition per measurement.  
 H. All parameters and waveforms are not applicable to all devices.

**Figure 1. Load Circuits and Voltage Waveforms**

**SN54LS373, SN54LS374, SN54S373, SN54S374,  
SN74LS373, SN74LS374, SN74S373, SN74S374  
OCTAL D-TYPE TRANSPARENT LATCHES AND EDGE-TRIGGERED FLIP-FLOPS**

SDLS165B – OCTOBER 1975 – REVISED AUGUST 2002

**PARAMETER MEASUREMENT INFORMATION  
SERIES 54S/74S DEVICES**

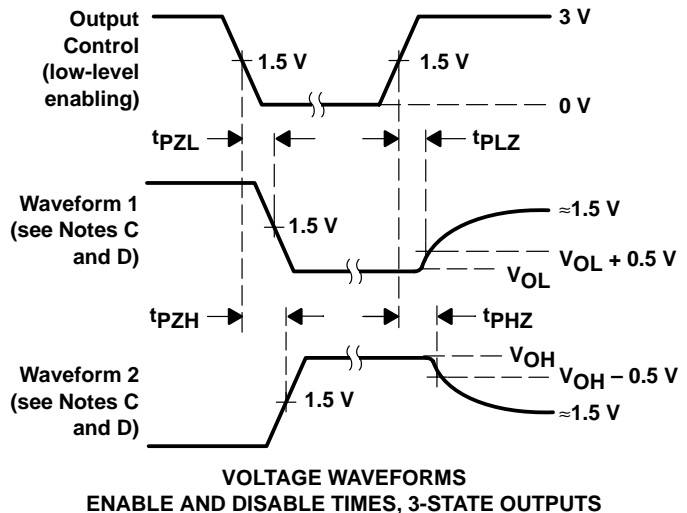
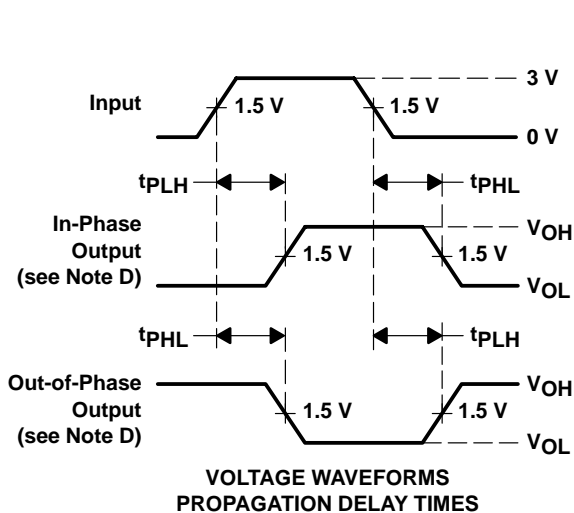
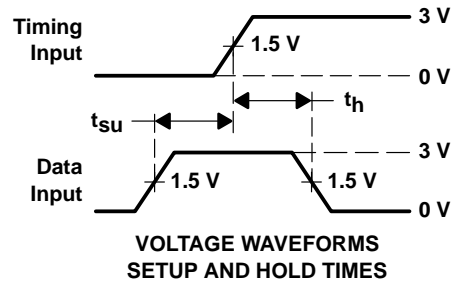
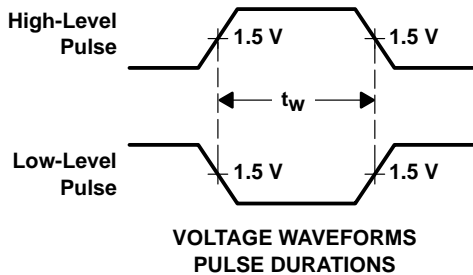
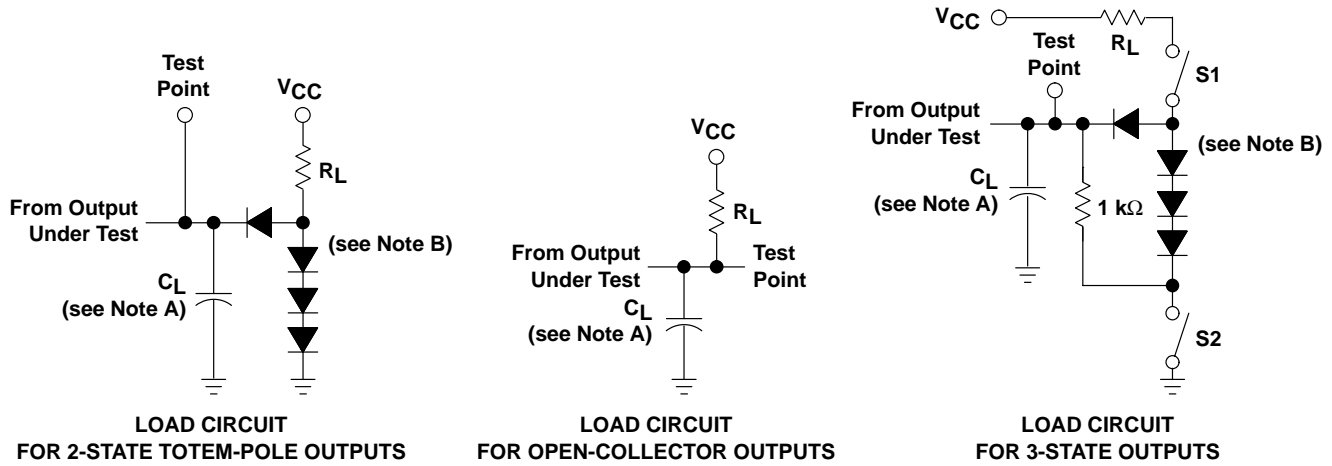

- NOTES: A.  $C_L$  includes probe and jig capacitance.  
 B. All diodes are 1N3064 or equivalent.  
 C. Waveform 1 is for an output with internal conditions such that the output is low except when disabled by the output control. Waveform 2 is for an output with internal conditions such that the output is high except when disabled by the output control.  
 D. S1 and S2 are closed for  $t_{PLH}$ ,  $t_{PHL}$ ,  $t_{PHZ}$ , and  $t_{PLZ}$ ; S1 is open and S2 is closed for  $t_{PZH}$ ; S1 is closed and S2 is open for  $t_{PZL}$ .  
 E. All input pulses are supplied by generators having the following characteristics:  $PRR \leq 1$  MHz,  $Z_O \approx 50 \Omega$ ;  $t_r$  and  $t_f \leq 7$  ns for Series 54/74 devices and  $t_r$  and  $t_f \leq 2.5$  ns for Series 54S/74S devices.  
 F. The outputs are measured one at a time with one input transition per measurement.  
 G. All parameters and waveforms are not applicable to all devices.

**Figure 2. Load Circuits and Voltage Waveforms**

**SN54LS373, SN54LS374, SN54S373, SN54S374,  
SN74LS373, SN74LS374, SN74S373, SN74S374**

SDLS165B – OCTOBER 1975 – REVISED AUGUST 2002

**TYPICAL APPLICATION DATA**

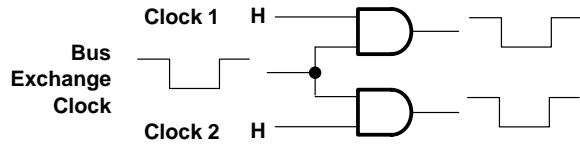
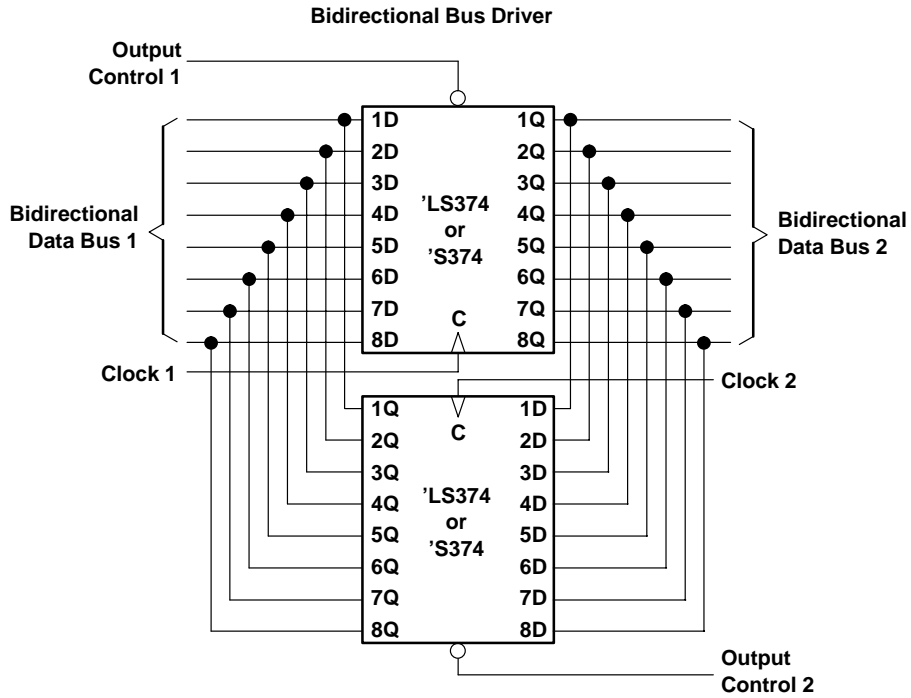

Clock Circuit for Bus Exchange

**Expandable 4-Word by 8-Bit General Register File**

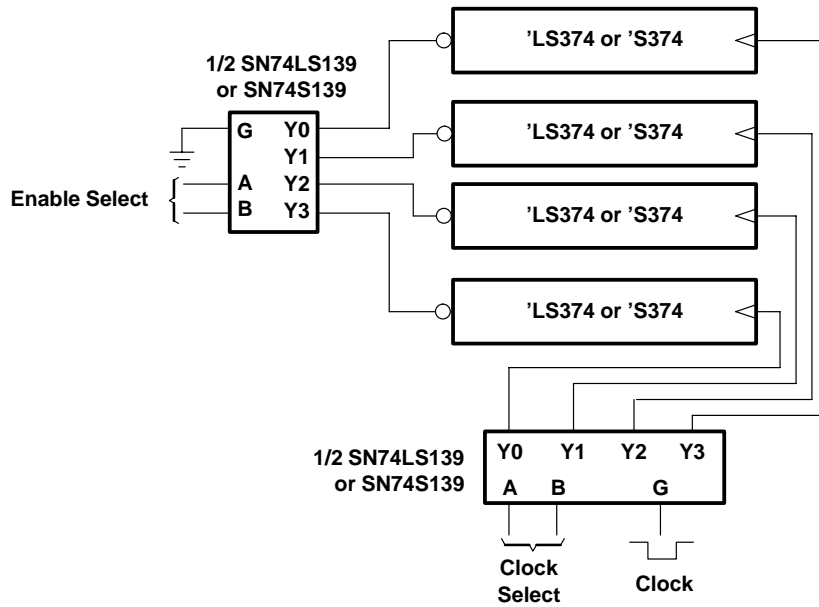

**PACKAGING INFORMATION**

Orderable Device	Status (1)	Package Type	Package Drawing	Pins	Package Qty	Eco Plan (2)	Lead finish/ Ball material (6)	MSL Peak Temp (3)	Op Temp (°C)	Device Marking (4/5)	Samples
78011022A	ACTIVE	LCCC	FK	20	55	Non-RoHS & Green	SNPB	N / A for Pkg Type	-55 to 125	78011022A SNJ54LS 374FK	<a href="#">Samples</a>
7801102RA	ACTIVE	CDIP	J	20	20	Non-RoHS & Green	SNPB	N / A for Pkg Type	-55 to 125	7801102RA SNJ54LS374J	<a href="#">Samples</a>
7801102SA	ACTIVE	CFP	W	20	25	Non-RoHS & Green	SNPB	N / A for Pkg Type	-55 to 125	7801102SA SNJ54LS374W	<a href="#">Samples</a>
JM38510/32502B2A	ACTIVE	LCCC	FK	20	55	Non-RoHS & Green	SNPB	N / A for Pkg Type	-55 to 125	JM38510/ 32502B2A	<a href="#">Samples</a>
JM38510/32502BRA	ACTIVE	CDIP	J	20	20	Non-RoHS & Green	SNPB	N / A for Pkg Type	-55 to 125	JM38510/ 32502BRA	<a href="#">Samples</a>
JM38510/32502BSA	ACTIVE	CFP	W	20	25	Non-RoHS & Green	SNPB	N / A for Pkg Type	-55 to 125	JM38510/ 32502BSA	<a href="#">Samples</a>
JM38510/32502SRA	ACTIVE	CDIP	J	20	20	Non-RoHS & Green	SNPB	N / A for Pkg Type	-55 to 125	JM38510/ 32502SRA	<a href="#">Samples</a>
JM38510/32502SSA	ACTIVE	CFP	W	20	25	Non-RoHS & Green	SNPB	N / A for Pkg Type	-55 to 125	JM38510/ 32502SSA	<a href="#">Samples</a>
JM38510/32503B2A	ACTIVE	LCCC	FK	20	55	Non-RoHS & Green	SNPB	N / A for Pkg Type	-55 to 125	JM38510/ 32503B2A	<a href="#">Samples</a>
JM38510/32503BRA	ACTIVE	CDIP	J	20	20	Non-RoHS & Green	SNPB	N / A for Pkg Type	-55 to 125	JM38510/ 32503BRA	<a href="#">Samples</a>
JM38510/32503BSA	ACTIVE	CFP	W	20	25	Non-RoHS & Green	SNPB	N / A for Pkg Type	-55 to 125	JM38510/ 32503BSA	<a href="#">Samples</a>
M38510/32502B2A	ACTIVE	LCCC	FK	20	55	Non-RoHS & Green	SNPB	N / A for Pkg Type	-55 to 125	JM38510/ 32502B2A	<a href="#">Samples</a>
M38510/32502BRA	ACTIVE	CDIP	J	20	20	Non-RoHS & Green	SNPB	N / A for Pkg Type	-55 to 125	JM38510/ 32502BRA	<a href="#">Samples</a>
M38510/32502BSA	ACTIVE	CFP	W	20	25	Non-RoHS & Green	SNPB	N / A for Pkg Type	-55 to 125	JM38510/ 32502BSA	<a href="#">Samples</a>
M38510/32502SRA	ACTIVE	CDIP	J	20	20	Non-RoHS & Green	SNPB	N / A for Pkg Type	-55 to 125	JM38510/ 32502SRA	<a href="#">Samples</a>
M38510/32502SSA	ACTIVE	CFP	W	20	25	Non-RoHS & Green	SNPB	N / A for Pkg Type	-55 to 125	JM38510/ 32502SSA	<a href="#">Samples</a>

Orderable Device	Status (1)	Package Type	Package Drawing	Pins	Package Qty	Eco Plan (2)	Lead finish/ Ball material (6)	MSL Peak Temp (3)	Op Temp (°C)	Device Marking (4/5)	Samples
M38510/32503B2A	ACTIVE	LCCC	FK	20	55	Non-RoHS & Green	SNPB	N / A for Pkg Type	-55 to 125	JM38510/ 32503B2A	<a href="#">Samples</a>
M38510/32503BRA	ACTIVE	CDIP	J	20	20	Non-RoHS & Green	SNPB	N / A for Pkg Type	-55 to 125	JM38510/ 32503BRA	<a href="#">Samples</a>
M38510/32503BSA	ACTIVE	CFP	W	20	25	Non-RoHS & Green	SNPB	N / A for Pkg Type	-55 to 125	JM38510/ 32503BSA	<a href="#">Samples</a>
SN54LS373J	ACTIVE	CDIP	J	20	20	Non-RoHS & Green	SNPB	N / A for Pkg Type	-55 to 125	SN54LS373J	<a href="#">Samples</a>
SN54LS374J	ACTIVE	CDIP	J	20	20	Non-RoHS & Green	SNPB	N / A for Pkg Type	-55 to 125	SN54LS374J	<a href="#">Samples</a>
SN54S373J	ACTIVE	CDIP	J	20	20	Non-RoHS & Green	SNPB	N / A for Pkg Type	-55 to 125	SN54S373J	<a href="#">Samples</a>
SN54S374J	ACTIVE	CDIP	J	20	20	Non-RoHS & Green	SNPB	N / A for Pkg Type	-55 to 125	SN54S374J	<a href="#">Samples</a>
SN74LS373DWR	ACTIVE	SOIC	DW	20	2000	RoHS & Green	NIPDAU	Level-1-260C-UNLIM	0 to 70	LS373	<a href="#">Samples</a>
SN74LS373N	ACTIVE	PDIP	N	20	20	RoHS & Green	NIPDAU	N / A for Pkg Type	0 to 70	SN74LS373N	<a href="#">Samples</a>
SN74LS373NE4	ACTIVE	PDIP	N	20	20	RoHS & Green	NIPDAU	N / A for Pkg Type	0 to 70	SN74LS373N	<a href="#">Samples</a>
SN74LS373NSR	ACTIVE	SO	NS	20	2000	RoHS & Green	NIPDAU	Level-1-260C-UNLIM	0 to 70	74LS373	<a href="#">Samples</a>
SN74LS374DBR	ACTIVE	SSOP	DB	20	2000	RoHS & Green	NIPDAU	Level-1-260C-UNLIM	0 to 70	LS374A	<a href="#">Samples</a>
SN74LS374DWR	ACTIVE	SOIC	DW	20	2000	RoHS & Green	NIPDAU	Level-1-260C-UNLIM	0 to 70	LS374	<a href="#">Samples</a>
SN74LS374N	ACTIVE	PDIP	N	20	20	RoHS & Green	NIPDAU	N / A for Pkg Type	0 to 70	SN74LS374N	<a href="#">Samples</a>
SN74LS374NE4	ACTIVE	PDIP	N	20	20	RoHS & Green	NIPDAU	N / A for Pkg Type	0 to 70	SN74LS374N	<a href="#">Samples</a>
SN74LS374NSR	ACTIVE	SO	NS	20	2000	RoHS & Green	NIPDAU	Level-1-260C-UNLIM	0 to 70	74LS374	<a href="#">Samples</a>
SN74S373N	ACTIVE	PDIP	N	20	20	RoHS & Non-Green	NIPDAU	N / A for Pkg Type	0 to 70	SN74S373N	<a href="#">Samples</a>
SN74S374N	ACTIVE	PDIP	N	20	20	RoHS & Non-Green	NIPDAU	N / A for Pkg Type	0 to 70	SN74S374N	<a href="#">Samples</a>
SNJ54LS373FK	ACTIVE	LCCC	FK	20	55	Non-RoHS & Green	SNPB	N / A for Pkg Type	-55 to 125	SNJ54LS 373FK	<a href="#">Samples</a>

Orderable Device	Status (1)	Package Type	Package Drawing	Pins	Package Qty	Eco Plan (2)	Lead finish/ Ball material (6)	MSL Peak Temp (3)	Op Temp (°C)	Device Marking (4/5)	Samples
SNJ54LS373J	ACTIVE	CDIP	J	20	20	Non-RoHS & Green	SNPB	N / A for Pkg Type	-55 to 125	SNJ54LS373J	<a href="#">Samples</a>
SNJ54LS373W	ACTIVE	CFP	W	20	25	Non-RoHS & Green	SNPB	N / A for Pkg Type	-55 to 125	SNJ54LS373W	<a href="#">Samples</a>
SNJ54LS374FK	ACTIVE	LCCC	FK	20	55	Non-RoHS & Green	SNPB	N / A for Pkg Type	-55 to 125	78011022A SNJ54LS 374FK	<a href="#">Samples</a>
SNJ54LS374J	ACTIVE	CDIP	J	20	20	Non-RoHS & Green	SNPB	N / A for Pkg Type	-55 to 125	7801102RA SNJ54LS374J	<a href="#">Samples</a>
SNJ54LS374W	ACTIVE	CFP	W	20	25	Non-RoHS & Green	SNPB	N / A for Pkg Type	-55 to 125	7801102SA SNJ54LS374W	<a href="#">Samples</a>
SNJ54S373FK	ACTIVE	LCCC	FK	20	55	Non-RoHS & Green	SNPB	N / A for Pkg Type	-55 to 125	SNJ54S 373FK	<a href="#">Samples</a>
SNJ54S373J	ACTIVE	CDIP	J	20	20	Non-RoHS & Green	SNPB	N / A for Pkg Type	-55 to 125	SNJ54S373J	<a href="#">Samples</a>
SNJ54S374FK	ACTIVE	LCCC	FK	20	55	Non-RoHS & Green	SNPB	N / A for Pkg Type	-55 to 125	SNJ54S 374FK	<a href="#">Samples</a>
SNJ54S374J	ACTIVE	CDIP	J	20	20	Non-RoHS & Green	SNPB	N / A for Pkg Type	-55 to 125	SNJ54S374J	<a href="#">Samples</a>
SNJ54S374W	ACTIVE	CFP	W	20	25	Non-RoHS & Green	SNPB	N / A for Pkg Type	-55 to 125	SNJ54S374W	<a href="#">Samples</a>

(1) The marketing status values are defined as follows:

**ACTIVE:** Product device recommended for new designs.

**LIFEBUY:** TI has announced that the device will be discontinued, and a lifetime-buy period is in effect.

**NRND:** Not recommended for new designs. Device is in production to support existing customers, but TI does not recommend using this part in a new design.

**PREVIEW:** Device has been announced but is not in production. Samples may or may not be available.

**OBSELETE:** TI has discontinued the production of the device.

(2) **RoHS:** TI defines "RoHS" to mean semiconductor products that are compliant with the current EU RoHS requirements for all 10 RoHS substances, including the requirement that RoHS substance do not exceed 0.1% by weight in homogeneous materials. Where designed to be soldered at high temperatures, "RoHS" products are suitable for use in specified lead-free processes. TI may reference these types of products as "Pb-Free".

**RoHS Exempt:** TI defines "RoHS Exempt" to mean products that contain lead but are compliant with EU RoHS pursuant to a specific EU RoHS exemption.

**Green:** TI defines "Green" to mean the content of Chlorine (Cl) and Bromine (Br) based flame retardants meet JS709B low halogen requirements of <=1000ppm threshold. Antimony trioxide based flame retardants must also meet the <=1000ppm threshold requirement.

(3) MSL, Peak Temp. - The Moisture Sensitivity Level rating according to the JEDEC industry standard classifications, and peak solder temperature.

(4) There may be additional marking, which relates to the logo, the lot trace code information, or the environmental category on the device.

(5) Multiple Device Markings will be inside parentheses. Only one Device Marking contained in parentheses and separated by a "~" will appear on a device. If a line is indented then it is a continuation of the previous line and the two combined represent the entire Device Marking for that device.

(6) Lead finish/Ball material - Orderable Devices may have multiple material finish options. Finish options are separated by a vertical ruled line. Lead finish/Ball material values may wrap to two lines if the finish value exceeds the maximum column width.

**Important Information and Disclaimer:**The information provided on this page represents TI's knowledge and belief as of the date that it is provided. TI bases its knowledge and belief on information provided by third parties, and makes no representation or warranty as to the accuracy of such information. Efforts are underway to better integrate information from third parties. TI has taken and continues to take reasonable steps to provide representative and accurate information but may not have conducted destructive testing or chemical analysis on incoming materials and chemicals. TI and TI suppliers consider certain information to be proprietary, and thus CAS numbers and other limited information may not be available for release.

In no event shall TI's liability arising out of such information exceed the total purchase price of the TI part(s) at issue in this document sold by TI to Customer on an annual basis.

**OTHER QUALIFIED VERSIONS OF SN54LS373, SN54LS373-SP, SN54LS374, SN54S373, SN54S374, SN74LS373, SN74LS374, SN74S373, SN74S374 :**

- Catalog : [SN74LS373](#), [SN54LS373](#), [SN74LS374](#), [SN74S373](#), [SN74S374](#)
- Military : [SN54LS373](#), [SN54LS374](#), [SN54S373](#), [SN54S374](#)
- Space : [SN54LS373-SP](#)

NOTE: Qualified Version Definitions:

- Catalog - TI's standard catalog product
- Military - QML certified for Military and Defense Applications
- Space - Radiation tolerant, ceramic packaging and qualified for use in Space-based application

**TAPE AND REEL INFORMATION**

**QUADRANT ASSIGNMENTS FOR PIN 1 ORIENTATION IN TAPE**



\*All dimensions are nominal

Device	Package Type	Package Drawing	Pins	SPQ	Reel Diameter (mm)	Reel Width W1 (mm)	A0 (mm)	B0 (mm)	K0 (mm)	P1 (mm)	W (mm)	Pin1 Quadrant
SN74LS373DWR	SOIC	DW	20	2000	330.0	24.4	10.8	13.3	2.7	12.0	24.0	Q1
SN74LS373NSR	SO	NS	20	2000	330.0	24.4	8.4	13.0	2.5	12.0	24.0	Q1
SN74LS374DBR	SSOP	DB	20	2000	330.0	16.4	8.2	7.5	2.5	12.0	16.0	Q1
SN74LS374DWR	SOIC	DW	20	2000	330.0	24.4	10.8	13.3	2.7	12.0	24.0	Q1
SN74LS374NSR	SO	NS	20	2000	330.0	24.4	8.4	13.0	2.5	12.0	24.0	Q1

**TAPE AND REEL BOX DIMENSIONS**

\*All dimensions are nominal

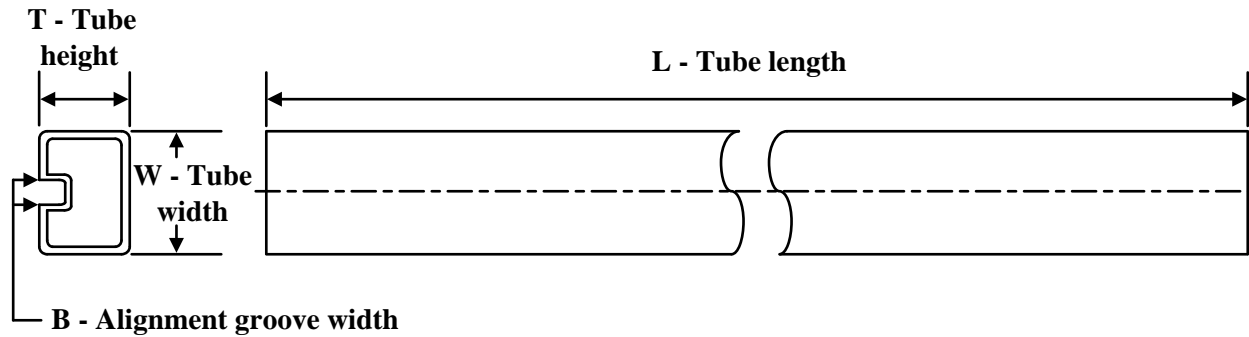
Device	Package Type	Package Drawing	Pins	SPQ	Length (mm)	Width (mm)	Height (mm)
SN74LS373DWR	SOIC	DW	20	2000	367.0	367.0	45.0
SN74LS373NSR	SO	NS	20	2000	367.0	367.0	45.0
SN74LS374DBR	SSOP	DB	20	2000	356.0	356.0	35.0
SN74LS374DWR	SOIC	DW	20	2000	367.0	367.0	45.0
SN74LS374NSR	SO	NS	20	2000	356.0	356.0	41.0

**TUBE**

\*All dimensions are nominal

Device	Package Name	Package Type	Pins	SPQ	L (mm)	W (mm)	T (µm)	B (mm)
78011022A	FK	LCCC	20	55	506.98	12.06	2030	NA
7801102SA	W	CFP	20	25	506.98	26.16	6220	NA
JM38510/32502B2A	FK	LCCC	20	55	506.98	12.06	2030	NA
JM38510/32502BSA	W	CFP	20	25	506.98	26.16	6220	NA
JM38510/32502SSA	W	CFP	20	25	506.98	26.16	6220	NA
JM38510/32503B2A	FK	LCCC	20	55	506.98	12.06	2030	NA
JM38510/32503BSA	W	CFP	20	25	506.98	26.16	6220	NA
M38510/32502B2A	FK	LCCC	20	55	506.98	12.06	2030	NA
M38510/32502BSA	W	CFP	20	25	506.98	26.16	6220	NA
M38510/32502SSA	W	CFP	20	25	506.98	26.16	6220	NA
M38510/32503B2A	FK	LCCC	20	55	506.98	12.06	2030	NA
M38510/32503BSA	W	CFP	20	25	506.98	26.16	6220	NA
SN74LS373N	N	PDIP	20	20	506	13.97	11230	4.32
SN74LS373NE4	N	PDIP	20	20	506	13.97	11230	4.32
SN74LS374N	N	PDIP	20	20	506	13.97	11230	4.32
SN74LS374NE4	N	PDIP	20	20	506	13.97	11230	4.32
SN74S373N	N	PDIP	20	20	506	13.97	11230	4.32
SN74S374N	N	PDIP	20	20	506	13.97	11230	4.32
SNJ54LS373FK	FK	LCCC	20	55	506.98	12.06	2030	NA
SNJ54LS373W	W	CFP	20	25	506.98	26.16	6220	NA
SNJ54LS374FK	FK	LCCC	20	55	506.98	12.06	2030	NA
SNJ54LS374W	W	CFP	20	25	506.98	26.16	6220	NA
SNJ54S373FK	FK	LCCC	20	55	506.98	12.06	2030	NA
SNJ54S374FK	FK	LCCC	20	55	506.98	12.06	2030	NA
SNJ54S374W	W	CFP	20	25	506.98	26.16	6220	NA

# DB0020A



# PACKAGE OUTLINE

## SSOP - 2 mm max height

SMALL OUTLINE PACKAGE



4214851/B 08/2019

### NOTES:

1. All linear dimensions are in millimeters. Any dimensions in parenthesis are for reference only. Dimensioning and tolerancing per ASME Y14.5M.
2. This drawing is subject to change without notice.
3. This dimension does not include mold flash, protrusions, or gate burrs. Mold flash, protrusions, or gate burrs shall not exceed 0.15 mm per side.
4. This dimension does not include interlead flash. Interlead flash shall not exceed 0.25 mm per side.
5. Reference JEDEC registration MO-150.

# EXAMPLE BOARD LAYOUT

DB0020A

SSOP - 2 mm max height

SMALL OUTLINE PACKAGE



LAND PATTERN EXAMPLE  
EXPOSED METAL SHOWN  
SCALE: 10X



4214851/B 08/2019

NOTES: (continued)

- 6. Publication IPC-7351 may have alternate designs.
- 7. Solder mask tolerances between and around signal pads can vary based on board fabrication site.

# EXAMPLE STENCIL DESIGN

DB0020A

SSOP - 2 mm max height

SMALL OUTLINE PACKAGE



SOLDER PASTE EXAMPLE  
BASED ON 0.125 mm THICK STENCIL  
SCALE: 10X

4214851/B 08/2019

NOTES: (continued)

8. Laser cutting apertures with trapezoidal walls and rounded corners may offer better paste release. IPC-7525 may have alternate design recommendations.
9. Board assembly site may have different recommendations for stencil design.

# MECHANICAL DATA

NS (R-PDSO-G\*\*)

PLASTIC SMALL-OUTLINE PACKAGE

14-PINS SHOWN



- NOTES:
- A. All linear dimensions are in millimeters.
  - B. This drawing is subject to change without notice.
  - C. Body dimensions do not include mold flash or protrusion, not to exceed 0,15.

J (R-GDIP-T\*\*)

14 LEADS SHOWN

CERAMIC DUAL IN-LINE PACKAGE

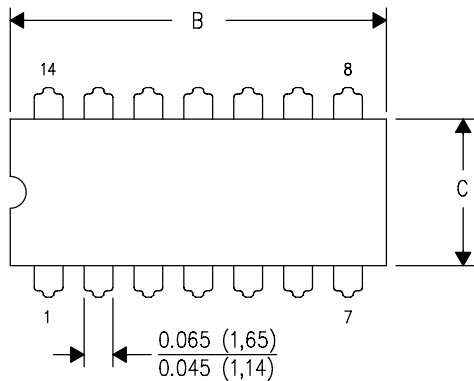

DIM \ PINS **	14	16	18	20
A	0.300 (7,62) BSC	0.300 (7,62) BSC	0.300 (7,62) BSC	0.300 (7,62) BSC
B MAX	0.785 (19,94)	.840 (21,34)	0.960 (24,38)	1.060 (26,92)
B MIN	—	—	—	—
C MAX	0.300 (7,62)	0.300 (7,62)	0.310 (7,87)	0.300 (7,62)
C MIN	0.245 (6,22)	0.245 (6,22)	0.220 (5,59)	0.245 (6,22)



4040083/F 03/03

- NOTES:
- All linear dimensions are in inches (millimeters).
  - This drawing is subject to change without notice.
  - This package is hermetically sealed with a ceramic lid using glass frit.
  - Index point is provided on cap for terminal identification only on press ceramic glass frit seal only.
  - Falls within MIL STD 1835 GDIP1-T14, GDIP1-T16, GDIP1-T18 and GDIP1-T20.

## GENERIC PACKAGE VIEW

**FK 20**

**LCCC - 2.03 mm max height**

8.89 x 8.89, 1.27 mm pitch

LEADLESS CERAMIC CHIP CARRIER

This image is a representation of the package family, actual package may vary.  
Refer to the product data sheet for package details.

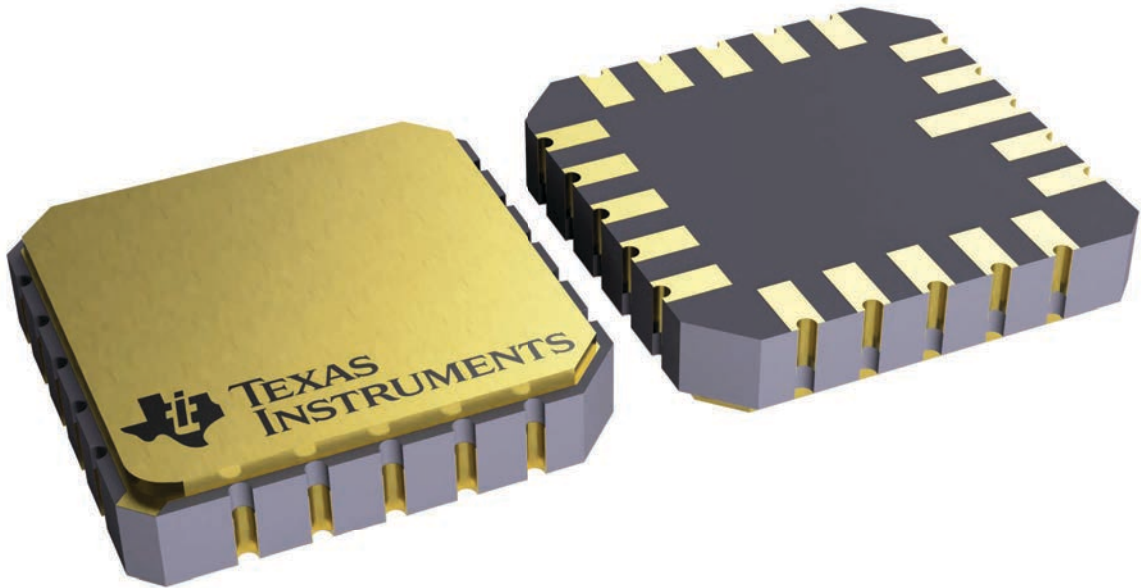

4229370VA\

N (R-PDIP-T\*\*)

PLASTIC DUAL-IN-LINE PACKAGE

16 PINS SHOWN



- NOTES:
- A. All linear dimensions are in inches (millimeters).
  - B. This drawing is subject to change without notice.
  - (C) Falls within JEDEC MS-001, except 18 and 20 pin minimum body length (Dim A).
  - (D) The 20 pin end lead shoulder width is a vendor option, either half or full width.

# DW0020A



# PACKAGE OUTLINE

## SOIC - 2.65 mm max height

SOIC



4220724/A 05/2016

**NOTES:**

1. All linear dimensions are in millimeters. Dimensions in parenthesis are for reference only. Dimensioning and tolerancing per ASME Y14.5M.
2. This drawing is subject to change without notice.
3. This dimension does not include mold flash, protrusions, or gate burrs. Mold flash, protrusions, or gate burrs shall not exceed 0.15 mm per side.
4. This dimension does not include interlead flash. Interlead flash shall not exceed 0.43 mm per side.
5. Reference JEDEC registration MS-013.

# EXAMPLE BOARD LAYOUT

DW0020A

SOIC - 2.65 mm max height

SOIC



LAND PATTERN EXAMPLE  
SCALE:6X



SOLDER MASK DETAILS

4220724/A 05/2016

NOTES: (continued)

- 6. Publication IPC-7351 may have alternate designs.
- 7. Solder mask tolerances between and around signal pads can vary based on board fabrication site.

# EXAMPLE STENCIL DESIGN

DW0020A

SOIC - 2.65 mm max height

SOIC



SOLDER PASTE EXAMPLE  
BASED ON 0.125 mm THICK STENCIL  
SCALE:6X

4220724/A 05/2016

NOTES: (continued)

8. Laser cutting apertures with trapezoidal walls and rounded corners may offer better paste release. IPC-7525 may have alternate design recommendations.
9. Board assembly site may have different recommendations for stencil design.

W (R-GDFP-F20)

CERAMIC DUAL FLATPACK



- NOTES:
- A. All linear dimensions are in inches (millimeters).
  - B. This drawing is subject to change without notice.
  - C. This package can be hermetically sealed with a ceramic lid using glass frit.
  - D. Index point is provided on cap for terminal identification only.
  - E. Falls within Mil-Std 1835 GDFP2-F20

## IMPORTANT NOTICE AND DISCLAIMER

TI PROVIDES TECHNICAL AND RELIABILITY DATA (INCLUDING DATA SHEETS), DESIGN RESOURCES (INCLUDING REFERENCE DESIGNS), APPLICATION OR OTHER DESIGN ADVICE, WEB TOOLS, SAFETY INFORMATION, AND OTHER RESOURCES "AS IS" AND WITH ALL FAULTS, AND DISCLAIMS ALL WARRANTIES, EXPRESS AND IMPLIED, INCLUDING WITHOUT LIMITATION ANY IMPLIED WARRANTIES OF MERCHANTABILITY, FITNESS FOR A PARTICULAR PURPOSE OR NON-INFRINGEMENT OF THIRD PARTY INTELLECTUAL PROPERTY RIGHTS.

These resources are intended for skilled developers designing with TI products. You are solely responsible for (1) selecting the appropriate TI products for your application, (2) designing, validating and testing your application, and (3) ensuring your application meets applicable standards, and any other safety, security, regulatory or other requirements.

These resources are subject to change without notice. TI grants you permission to use these resources only for development of an application that uses the TI products described in the resource. Other reproduction and display of these resources is prohibited. No license is granted to any other TI intellectual property right or to any third party intellectual property right. TI disclaims responsibility for, and you will fully indemnify TI and its representatives against, any claims, damages, costs, losses, and liabilities arising out of your use of these resources.

TI's products are provided subject to [TI's Terms of Sale](#) or other applicable terms available either on [ti.com](https://www.ti.com) or provided in conjunction with such TI products. TI's provision of these resources does not expand or otherwise alter TI's applicable warranties or warranty disclaimers for TI products.

TI objects to and rejects any additional or different terms you may have proposed.

Mailing Address: Texas Instruments, Post Office Box 655303, Dallas, Texas 75265  
Copyright © 2024, Texas Instruments Incorporated

## Looking for pricing, stock, or lifecycle information?

Click below to explore more details on WIN SOURCE:

 [View SN74LS374DW](#) on WIN SOURCE

 [Texas Instruments](#) Information

## Optimize Your Supply Chain with WIN SOURCE Solutions

-  Global Sourcing Solution
-  Obsolete Management
-  Cost Control Management
-  Shortage Management
-  Alternative Solution
-  Excess Inventory Management