



**THE DATASHEET OF
SN74LS193N**



SN54192, SN54193, SN54LS192, SN54LS193, SN74192, SN74193, SN74LS192, SN74LS193 SYNCHRONOUS 4-BIT UP/DOWN COUNTERS (DUAL CLOCK WITH CLEAR)

SDLS074 - DECEMBER 1972 - REVISED MARCH 1988

- Cascading Circuitry Provided Internally
- Synchronous Operation
- Individual Preset to Each Flip-Flop
- Fully Independent Clear Input

SN54192, SN54193, SN54LS192,
SN54LS193 . . . J OR W PACKAGE
SN74192, SN74193 . . . N PACKAGE
SN74LS192, SN74LS193 . . . D OR N PACKAGE

TYPES	TYPICAL MAXIMUM COUNT FREQUENCY	TYPICAL POWER DISSIPATION
'192, '193	32 MHz	325 mW
'LS192, 'LS193	32 MHz	95 mW

(TOP VIEW)

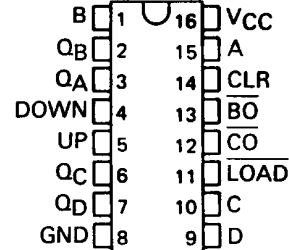

description

These monolithic circuits are synchronous reversible (up/down) counters having a complexity of 55 equivalent gates. The '192 and 'LS192 circuits are BCD counters and the '193 and 'LS193 are 4-bit binary counters. Synchronous operation is provided by having all flip-flops clocked simultaneously so that the outputs change coincidentally with each other when so instructed by the steering logic. This mode of operation eliminates the output counting spikes which are normally associated with asynchronous (ripple-clock) counters.

The outputs of the four master-slave flip-flops are triggered by a low-to-high-level transition of either count (clock) input. The direction of counting is determined by which count input is pulsed while the other count input is high.

All four counters are fully programmable; that is, each output may be preset to either level by entering the desired data at the data inputs while the load input is low. The output will change to agree with the data inputs independently of the count pulses. This feature allows the counters to be used as modulo-N dividers by simply modifying the count length with the preset inputs.

A clear input has been provided which forces all outputs to the low level when a high level is applied. The clear function is independent of the count and load inputs. The clear, count, and load inputs are buffered to lower the drive requirements. This reduces the number of clock drivers, etc., required for long words.

These counters were designed to be cascaded without the need for external circuitry. Both borrow and carry outputs are available to cascade both the up- and down-counting functions. The borrow output produces a pulse equal in width to the count-down input when the counter underflows. Similarly, the carry output produces a pulse equal in width to the count-up input when an overflow condition exists. The counters can then be easily cascaded by feeding the borrow and carry outputs to the count-down and count-up inputs respectively of the succeeding counter.

SN54LS192, SN54LS193 . . . FK PACKAGE
(TOP VIEW)

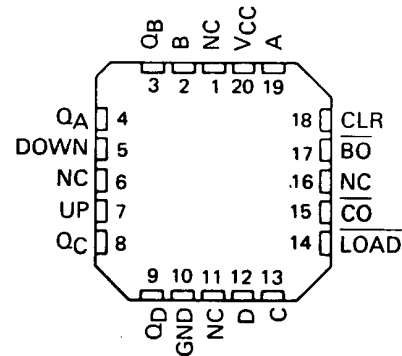

NC - No internal connection

absolute maximum ratings over operating free-air temperature range (unless otherwise noted)

	SN54'	SN54LS'	SN74'	SN74LS'	UNIT
Supply voltage, V_{CC} (see Note 1)	7	7	7	7	V
Input voltage	5.5	7	5.5	7	V
Operating free-air temperature range	-55 to 125		0 to 70		°C
Storage temperature range	-65 to 150		-65 to 150		°C

NOTE 1: Voltage values are with respect to network ground terminal.

PRODUCTION DATA information is current as of publication date. Products conform to specifications per the terms of Texas Instruments standard warranty. Production processing does not necessarily include testing of all parameters.

 **TEXAS
INSTRUMENTS**

POST OFFICE BOX 655303 • DALLAS, TEXAS 75265

Copyright © 1988, Texas Instruments Incorporated

SN54192, SN54LS192, SN74192, SN74LS192 SYNCHRONOUS 4-BIT UP/DOWN COUNTERS (DUAL CLOCK WITH CLEAR)

SDLS074 – DECEMBER 1972 – REVISED MARCH 1988

logic diagram (positive logic)

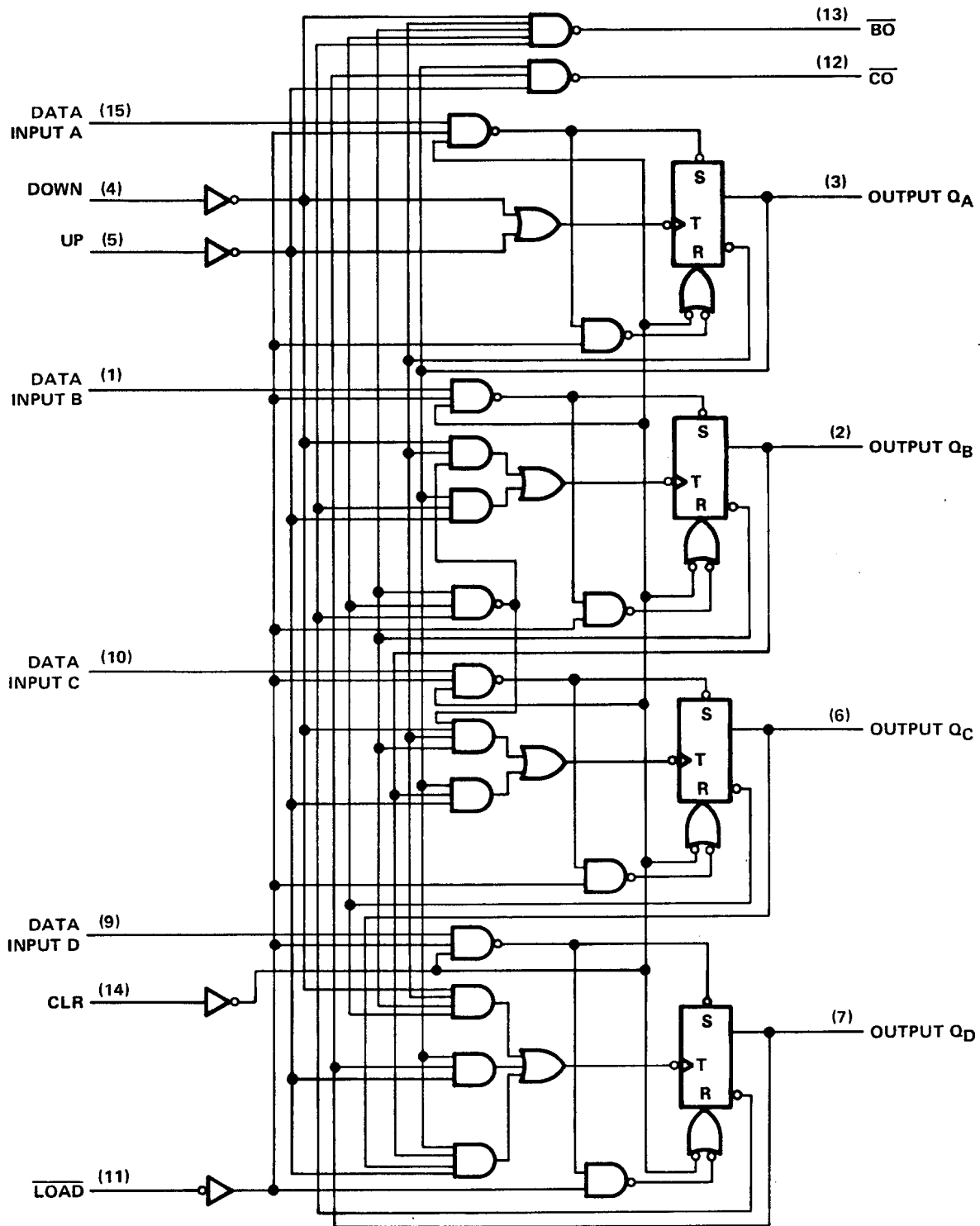

Pin numbers shown are for D, J, N, and W packages.



POST OFFICE BOX 655303 • DALLAS, TEXAS 75265

SN54193, SN54LS193, SN74193, SN74LS193 SYNCHRONOUS 4-BIT UP/DOWN COUNTERS (DUAL CLOCK WITH CLEAR)

SDLS074 - DECEMBER 1972 - REVISED MARCH 1988

logic diagram (positive logic)

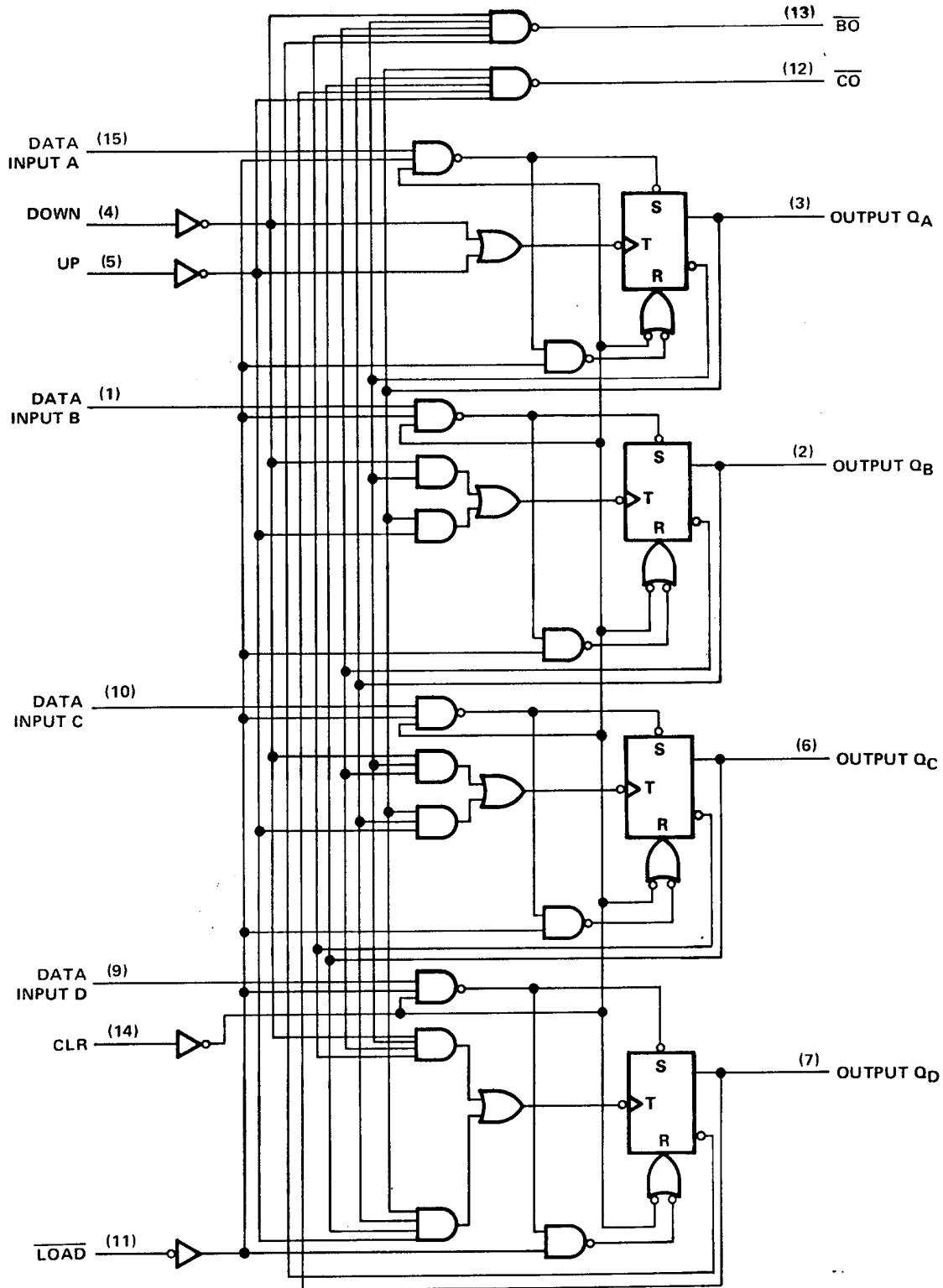

Pin numbers shown are for D, J, N, and W packages.



POST OFFICE BOX 655303 • DALLAS, TEXAS 75265

**SN54192, SN54193, SN54LS192, SN54LS193,
SN74192, SN74193, SN74LS192, SN74LS193
SYNCHRONOUS 4-BIT UP/DOWN COUNTERS (DUAL CLOCK WITH CLEAR)**

SDLS074 - DECEMBER 1972 - REVISED MARCH 1988

logic symbols†

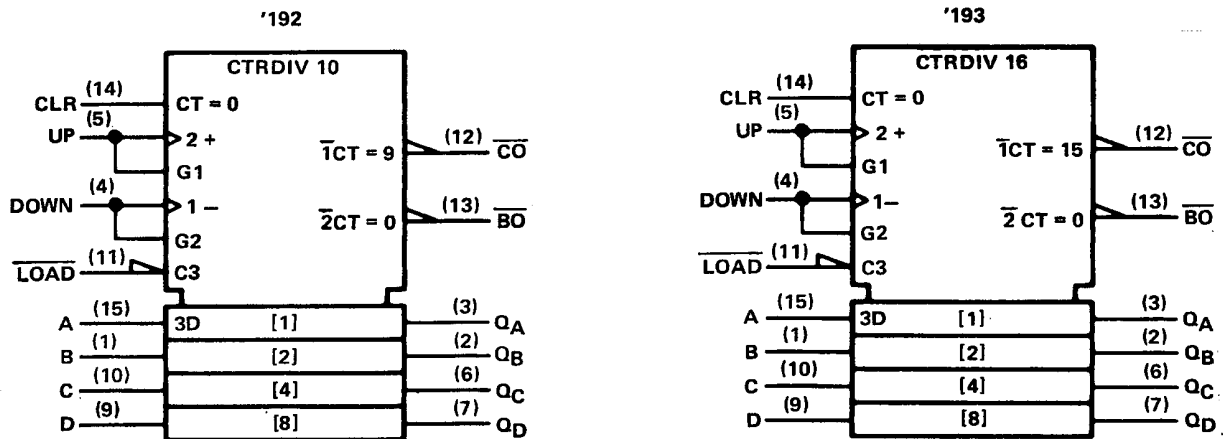

†These symbols are in accordance with ANSI/IEEE Std. 91-1984 and IEC Publication 617-12.

Pin numbers shown are for D, J, N, and W packages.

schematics of inputs and outputs

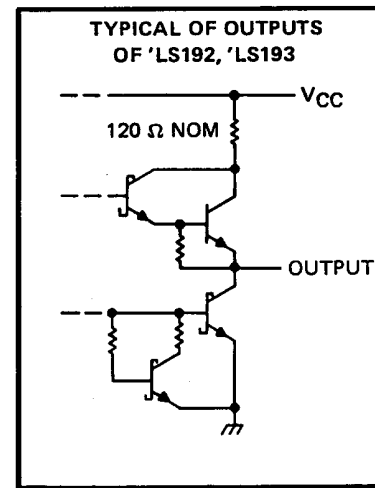
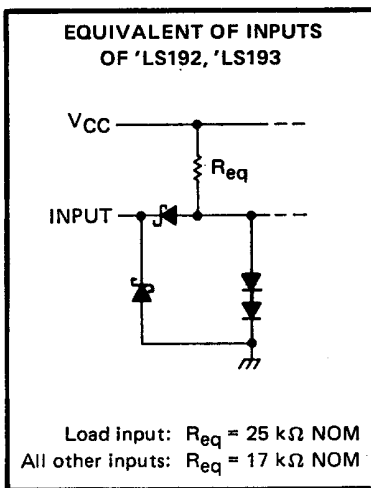
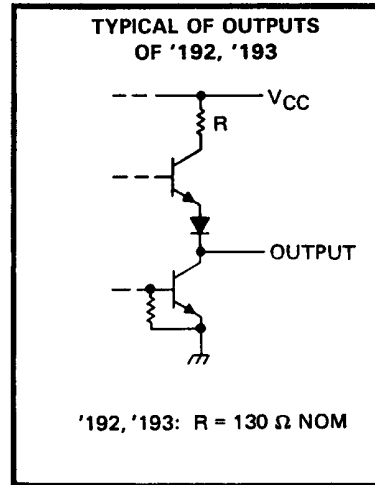
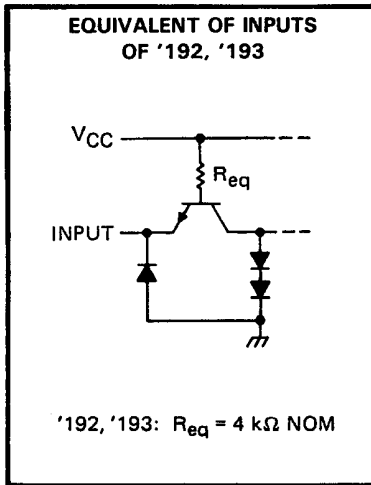

SN54192, SN54LS192, SN74192, SN74LS192 SYNCHRONOUS 4-BIT UP/DOWN COUNTERS (DUAL CLOCK WITH CLEAR)

SDLS074 - DECEMBER 1972 - REVISED MARCH 1988

'192, 'LS192 DECADE COUNTERS

typical clear, load, and count sequences

Illustrated below is the following sequence:

1. Clear outputs to zero.
2. Load (preset) to BCD seven.
3. Count up to eight, nine, carry, zero, one, and two.
4. Count down to one, zero, borrow, nine, eight, and seven.

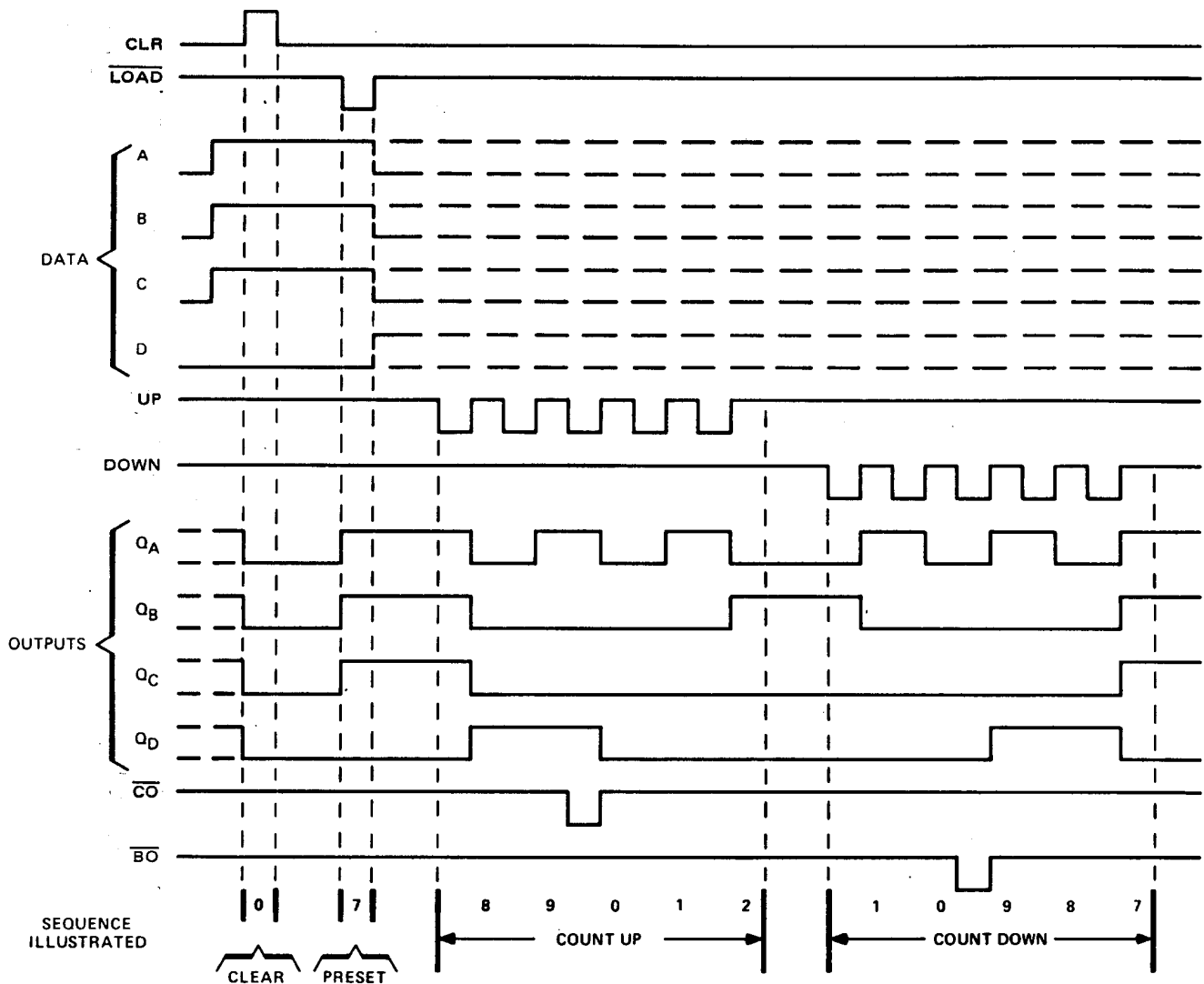

NOTES: A. Clear overrides load, data, and count inputs.

B. When counting up, count-down input must be high; when counting down, count-up input must be high.



SN54193, SN54LS193, SN74193, SN74LS193 SYNCHRONOUS 4-BIT UP/DOWN COUNTERS (DUAL CLOCK WITH CLEAR)

SDLS074 – DECEMBER 1972 – REVISED MARCH 1988

'193, 'LS193 BINARY COUNTERS

typical clear, load, and count sequences

Illustrated below is the following sequence:

1. Clear outputs to zero.
2. Load (preset) to binary thirteen.
3. Count up to fourteen, fifteen, carry, zero, one, and two.
4. Count down to one, zero, borrow, fifteen, fourteen, and thirteen.

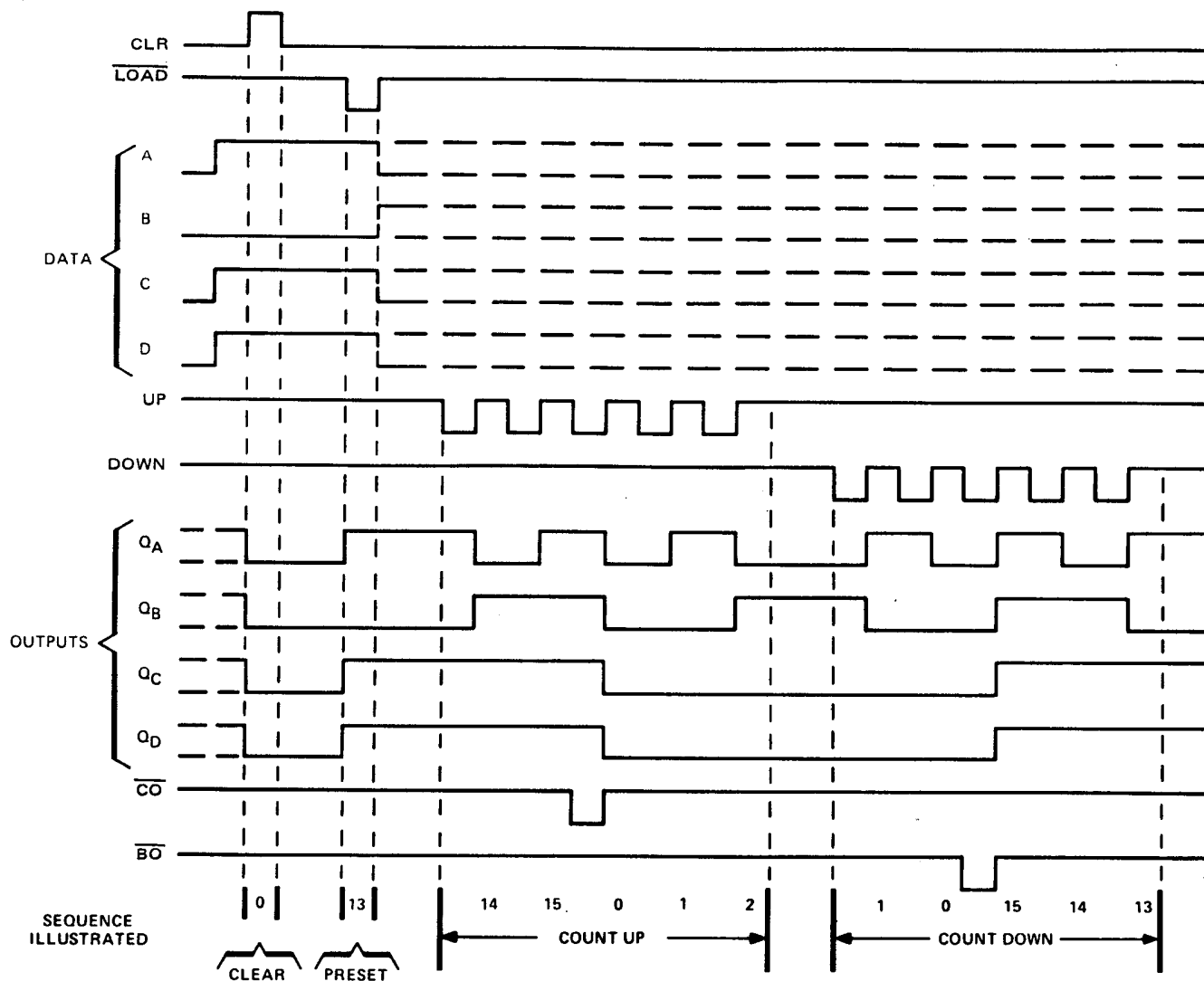

- NOTES: A. Clear overrides load, data, and count inputs.
 B. When counting up, count-down input must be high; when counting down, count-up input must be high.



POST OFFICE BOX 655303 • DALLAS, TEXAS 75265

SN54192, SN54193, SN74192, SN74193 SYNCHRONOUS 4-BIT UP/DOWN COUNTERS (DUAL CLOCK WITH CLEAR)

SDLS074 - DECEMBER 1972 - REVISED MARCH 1988

recommended operating conditions

		SN54192 SN54193			SN74192 SN74193			UNIT
		MIN	NOM	MAX	MIN	NOM	MAX	
V _{CC}	Supply voltage	4.5	5	5.5	4.75	5	5.25	V
I _{OH}	High-level output current			-0.4			-0.4	mA
I _{OL}	Low-level output current			16			16	mA
f _{clock}	Clock frequency	0		25	0		25	MHz
t _w	Width of any input pulse	20			20			ns
t _{su}	Data setup time, (see Figure 1)	20			20			ns
t _h	Hold time	Data, high or low			0			ns
		LOAD			3			
T _A	Operating free-air temperature	-55		125	0		70	°C

electrical characteristics over recommended operating free-air temperature range (unless otherwise noted)

PARAMETER	TEST CONDITIONS†	SN54192 SN54193			SN74192 SN74193			UNIT	
		MIN	TYP‡	MAX	MIN	TYP‡	MAX		
V _{IH}	High-level input voltage		2			2		V	
V _{IL}	Low-level input voltage			0.8			0.8	V	
V _{IK}	Input clamp voltage	V _{CC} = MIN, I _I = -12 mA					-1.5	V	
V _{OH}	High-level output voltage	V _{CC} = MIN, V _{IH} = 2 V, V _{IL} = 0.8 V, I _{OH} = -0.4 mA			2.4	3.4		2.4 3.4	V
V _{OL}	Low-level output voltage	V _{CC} = MIN, V _{IH} = 2 V, V _{IL} = 0.8 V, I _{OL} = 16 mA				0.2 0.4		0.2 0.4	V
I _I	Input current at maximum input voltage	V _{CC} = MAX, V _I = 5.5 V					1	1	mA
I _{IH}	High-level input current	V _{CC} = MAX, V _I = 2.4 V					40	40	μA
I _{IL}	Low-level input current	V _{CC} = MAX, V _I = 0.4 V					-1.6	-1.6	mA
I _{OS}	Short-circuit output current§	V _{CC} = MAX			-20		-65	-18 -65	mA
I _{CC}	Supply current	V _{CC} = MAX, See Note 2				65 89		65 102	mA

† For conditions shown as MIN or MAX, use the appropriate value specified under recommended operating conditions for the applicable type.

‡ All typical values are at V_{CC} = 5 V, T_A = 25°C.

§ Not more than one output should be shorted at a time.

NOTE 2: I_{CC} is measured with all outputs open, clear and load inputs grounded, and all other inputs at 4.5 V.

switching characteristics, V_{CC} = 5 V, T_A = 25°C

PARAMETER¶	FROM INPUT	TO OUTPUT	TEST CONDITIONS	MIN	TYP	MAX	UNIT
f _{max}			C _L = 15 pF, R _L = 400 Ω, See Figures 1 and 2	25	32		MHz
t _{PLH}	UP	\overline{CO}			17	26	ns
t _{PHL}					16	24	
t _{PLH}	DOWN	\overline{BO}			16	24	ns
t _{PHL}					16	24	
t _{PLH}	UP OR DOWN	Q			25	38	ns
t _{PHL}					31	47	
t _{PLH}	\overline{LOAD}	Q			27	40	ns
t _{PHL}					29	40	
t _{PHL}	CLR	Q			22	35	ns

¶ f_{max} ≡ maximum clock frequency

t_{PLH} ≡ propagation delay time, low-to-high-level output

t_{PHL} ≡ propagation delay time, high-to-low-level output



SN54LS192, SN54LS193, SN74LS192, SN74LS193 SYNCHRONOUS 4-BIT UP/DOWN COUNTERS (DUAL CLOCK WITH CLEAR)

SDLS074 – DECEMBER 1972 – REVISED MARCH 1988

recommended operating conditions

		SN54LS192 SN54LS193			SN74LS192 SN74LS193			UNIT
		MIN	NOM	MAX	MIN	NOM	MAX	
V _{CC}	Supply voltage	4.5	5	5.5	4.75	5	5.25	V
I _{OH}	High-level output current			-400			-400	μA
I _{OL}	Low-level output current			4			8	mA
f _{clock}	Clock frequency	0		25	0		25	MHz
t _w	Width of any input pulse	20			20			ns
t _{su}	Clear inactive-state setup time	15			15			ns
	Load inactive-state setup time	15			15			ns
	Data setup time (see Figure 1)	20			20			ns
t _h	Data hold time	5			5			ns
T _A	Operating free-air temperature range	-55		125	0		70	°C

electrical characteristics over recommended operating free-air temperature range (unless otherwise noted)

PARAMETER	TEST CONDITIONS†	SN54LS192 SN54LS193			SN74LS192 SN74LS193			UNIT	
		MIN	TYP‡	MAX	MIN	TYP‡	MAX		
V _{IH}	High-level input voltage	2			2			V	
V _{IL}	Low-level input voltage			0.7			0.8	V	
V _{IK}	Input clamp voltage	V _{CC} = MIN, I _I = -18 mA		-1.5			-1.5	V	
V _{OH}	High-level output voltage	V _{CC} = MIN, V _{IH} = 2 V, V _{IL} = V _{IL max} , I _{OH} = -400 μA		2.5	3.4		2.7	3.4	V
V _{OL}	Low-level output voltage	V _{CC} = MIN, V _{IH} = 2 V, V _{IL} = V _{IL max}		I _{OL} = 4 mA	0.25	0.4	0.15	0.4	V
		I _{OL} = 8 mA			0.35	0.5			
I _I	Input current at maximum input voltage	V _{CC} = MAX, V _I = 7 V		0.1		0.1		mA	
I _{IH}	High-level input current	V _{CC} = MAX, V _I = 2.7 V		20		20		μA	
I _{IL}	Low-level input current	V _{CC} = MAX, V _I = 0.4 V		-0.4		-0.4		mA	
I _{OS}	Short-circuit output current§	V _{CC} = MAX		-20	-100	-20	-100	mA	
I _{CC}	Supply current	V _{CC} = MAX, See Note 2		19	34	19	34	mA	

† For conditions shown as MIN or MAX, use the appropriate value specified under recommended operating conditions for the applicable type.

‡ All typical values are at V_{CC} = 5 V, T_A = 25°C.

§ Not more than one output should be shorted at a time, and duration of the short-circuit should not exceed one second.

NOTE 2: I_{CC} is measured with all outputs open, clear and load inputs grounded, and all other inputs at 4.5 V.

switching characteristics, V_{CC} = 5 V, T_A = 25°C

PARAMETER	FROM INPUT	TO OUTPUT	TEST CONDITIONS	MIN	TYP	MAX	UNIT
f _{max}			C _L = 15 pF, R _L = 2 kΩ, See Figures 1 and 2	25	32		MHz
t _{PLH}	UP	\overline{CO}			17	26	ns
t _{PHL}					18	24	
t _{PLH}	DOWN	\overline{BO}			16	24	ns
t _{PHL}					15	24	
t _{PLH}	UP OR DOWN	Q			27	38	ns
t _{PHL}					30	47	
t _{PLH}	\overline{LOAD}	Q			24	40	ns
t _{PHL}					25	40	
t _{PHL}	CLR	Q			23	35	ns



SN54192, SN54193, SN54LS192, SN54LS193,
 SN74192, SN74193, SN74LS192, SN74LS193
 SYNCHRONOUS 4-BIT UP/DOWN COUNTERS (DUAL CLOCK WITH CLEAR)

SDLS074 - DECEMBER 1972 - REVISED MARCH 1988

PARAMETER MEASUREMENT INFORMATION

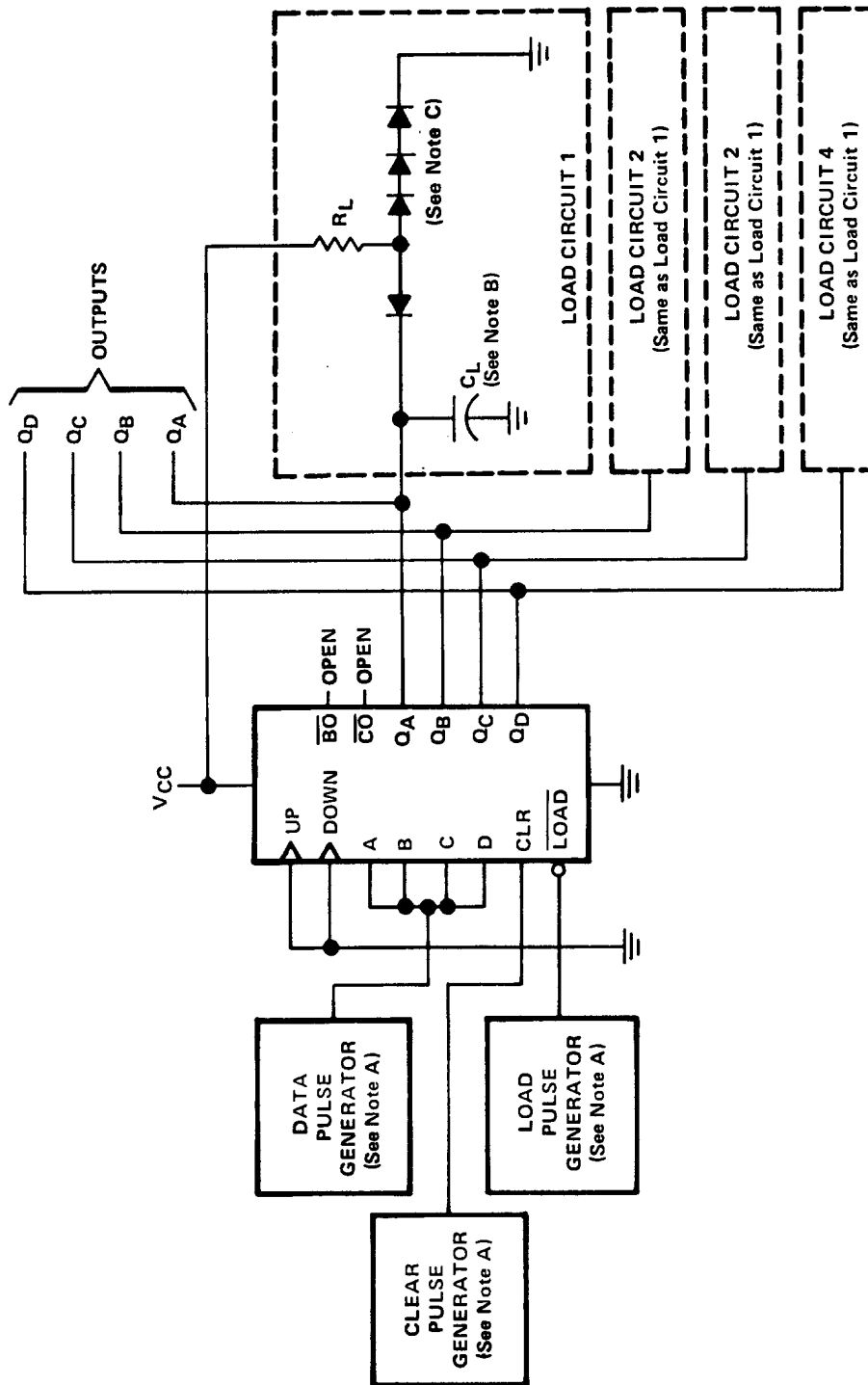

TEST CIRCUIT

- NOTES: A. The pulse generators have the following characteristics: $Z_{out} \approx 50 \Omega$ and for the data pulse generator $PRR \leq 500 \text{ kHz}$, duty cycle = 50%; for the load pulse generator PRR is two times data PRR , duty cycle = 50%.
- B. C_L includes probe and jig capacitance.
- C. Diodes are 1N3064 or equivalent.
- D. t_r and $t_f \leq 7 \text{ ns}$.
- E. V_{ref} is 1.5 V for '192 and '193, 1.3 V for 'LS192 and 'LS193.

FIGURE 1A - CLEAR, SETUP AND LOAD TIMES

**SN54192, SN54193, SN54LS192, SN54LS193,
SN74192, SN74193, SN74LS192, SN74LS193
SYNCHRONOUS 4-BIT UP/DOWN COUNTERS (DUAL CLOCK WITH CLEAR)**
SDLS074 - DECEMBER 1972 - REVISED MARCH 1988

PARAMETER MEASUREMENT INFORMATION

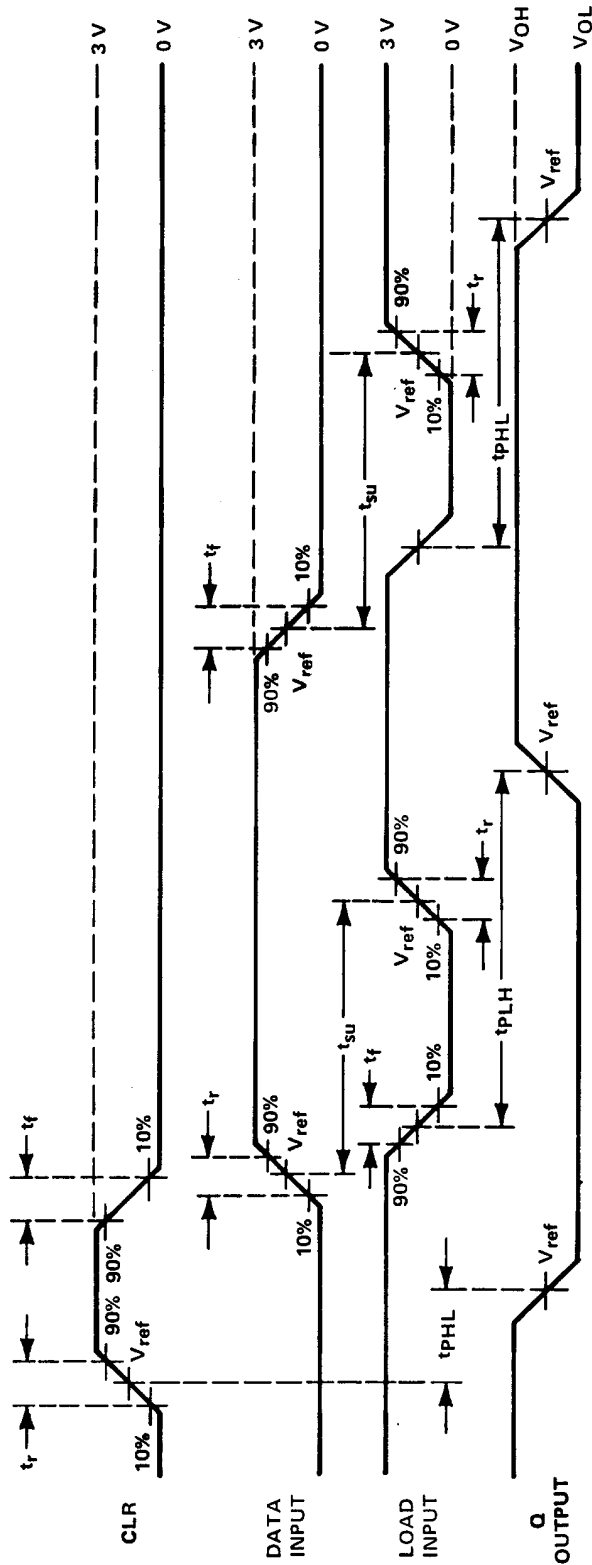

VOLTAGE WAVEFORMS

- NOTES:**
- A. The pulse generators have the following characteristics: $Z_{out} \approx 50 \Omega$ and for the data pulse generator PRR ≤ 500 kHz, duty cycle = 50%; for the load pulse generator PRR is two times data PRR, duty cycle = 50%
 - B. C_L includes probe and jig capacitance.
 - C. Diodes are 1N3064 or equivalent.
 - D. t_r and $t_f \leq 7$ ns.
 - E. V_{ref} is 1.5 V for '192 and '193, 1.3 V for 'LS192 and 'LS193.

FIGURE 1B - CLEAR, SETUP, AND LOAD TIMES

**SN54192, SN54193, SN54LS192, SN54LS193,
SN74192, SN74193, SN74LS192, SN74LS193**
SYNCHRONOUS 4-BIT UP/DOWN COUNTERS (DUAL CLOCK WITH CLEAR)

SDLS074 - DECEMBER 1972 - REVISED MARCH 1988

PARAMETER MEASUREMENT INFORMATION

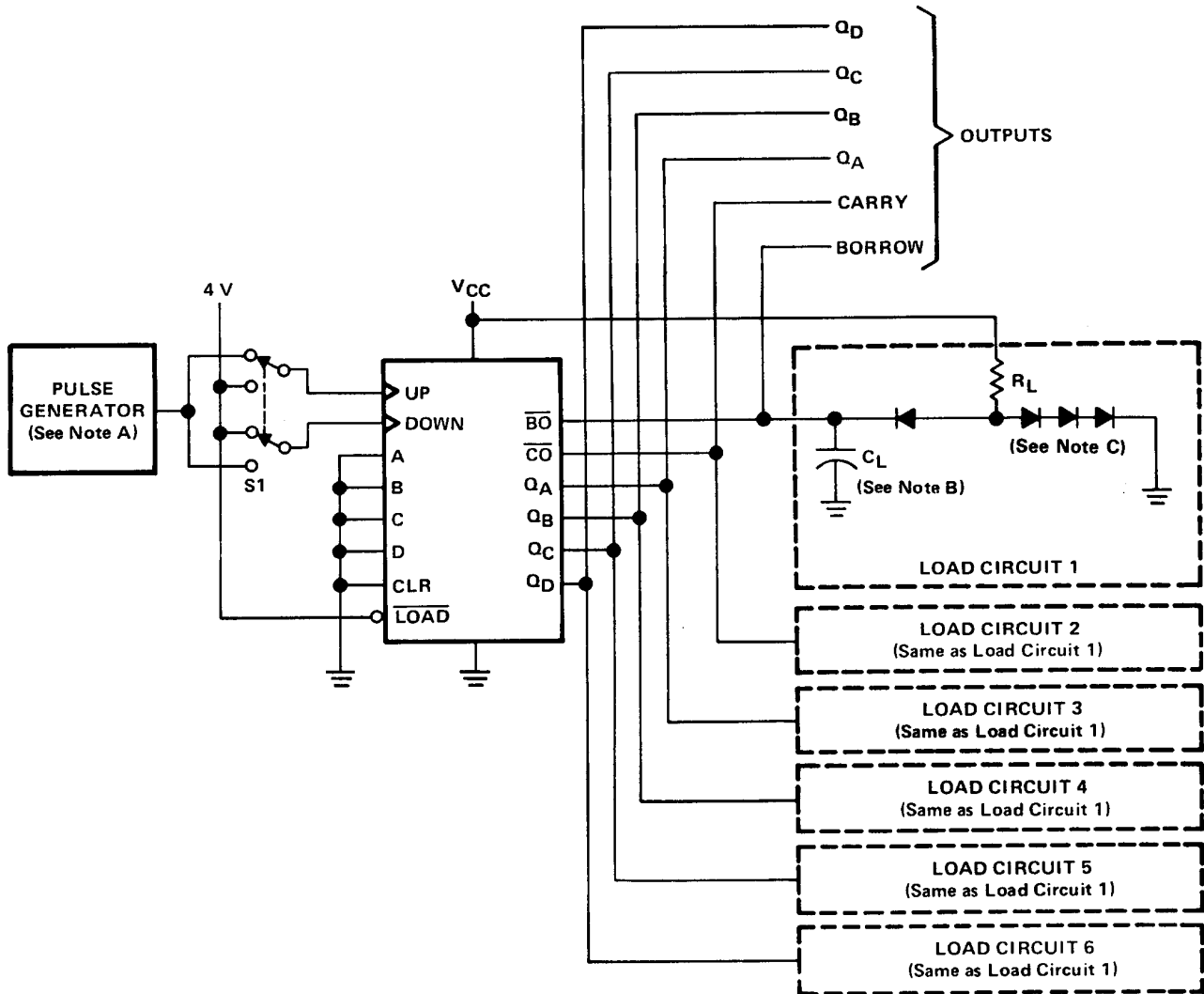

TEST CIRCUIT

- NOTES:**
- A. The pulse generators have the following characteristics: PRR \approx 1 MHz, $Z_{out} \approx$ 50 Ω , duty cycle = 50%.
 - B. C_L includes probe and jig capacitance.
 - C. Diodes are 1N3064 or equivalent.
 - D. Count-up and count-down pulse shown are for the '193 and 'LS193 binary counters. Count cycle for '192 and 'LS192 decade counters is 1 through 10.
 - E. Waveforms for outputs Q_A , Q_B , and Q_C are omitted to simplify the drawing.
 - F. t_r and $t_f \leq$ 7 ns.
 - G. V_{ref} is 1.5 V for '192 and '193, 1.3 V for 'LS192 and 'LS193.

FIGURE 2A - PROPAGATION DELAY TIMES

**SN54192, SN54193, SN54LS192, SN54LS193,
SN74192, SN74193, SN74LS192, SN74LS193
SYNCHRONOUS 4-BIT UP/DOWN COUNTERS (DUAL CLOCK WITH CLEAR)**

SDLS074 - DECEMBER 1972 - REVISED MARCH 1988

PARAMETER MEASUREMENT INFORMATION

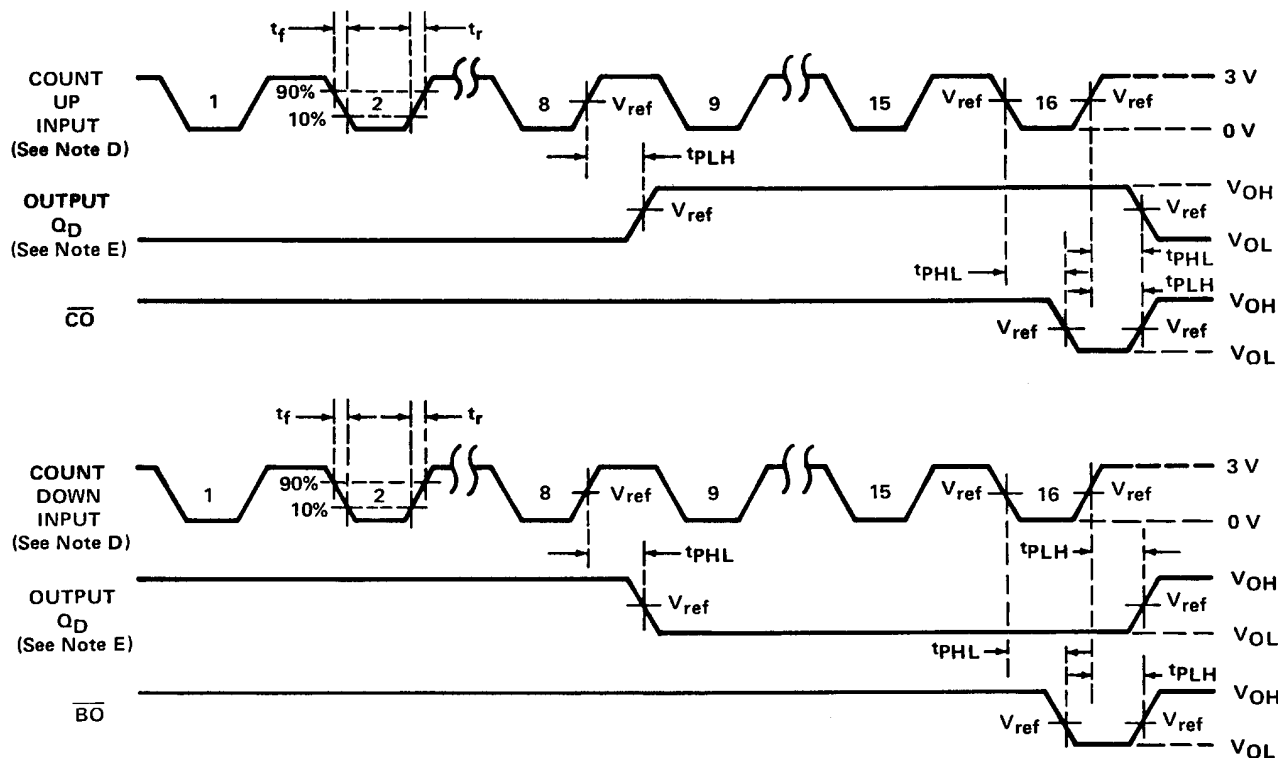

VOLTAGE WAVEFORMS

- NOTES: A. The pulse generators have the following characteristics: PRR \approx 1 MHz, $Z_{out} \approx 50 \Omega$, duty cycle = 50%.
 B. C_L includes probe and jig capacitance.
 C. Diodes are 1N3064 or equivalent.
 D. Count-up and count-down pulse shown are for the '193 and 'LS193 binary counters. Count cycle for '192 and 'LS192 decade counters is 1 through 10.
 E. Waveforms for outputs Q_A , Q_B , and Q_C are omitted to simplify the drawing.
 F. t_r and $t_f \leq 7$ ns.
 G. V_{ref} is 1.5 V for '192 and '193, 1.3 V for 'LS192 and 'LS193.

FIGURE 2B - PROPAGATION DELAY TIMES



PACKAGING INFORMATION

Orderable Device	Status (1)	Package Type	Package Drawing	Pins	Package Qty	Eco Plan (2)	Lead/Ball Finish (6)	MSL Peak Temp (3)	Op Temp (°C)	Device Marking (4/5)	Samples
5962-9558401QEA	ACTIVE	CDIP	J	16	1	TBD	A42	N / A for Pkg Type	-55 to 125	5962-9558401QE A SNJ54192J	Samples
5962-9558401QFA	ACTIVE	CFP	W	16	1	TBD	A42	N / A for Pkg Type	-55 to 125	5962-9558401QF A SNJ54192W	Samples
5962-9558401QFA	ACTIVE	CFP	W	16	1	TBD	A42	N / A for Pkg Type	-55 to 125	5962-9558401QF A SNJ54192W	Samples
76006012A	ACTIVE	LCCC	FK	20	1	TBD	POST-PLATE	N / A for Pkg Type	-55 to 125	76006012A SNJ54LS 193FK	Samples
76006012A	ACTIVE	LCCC	FK	20	1	TBD	POST-PLATE	N / A for Pkg Type	-55 to 125	76006012A SNJ54LS 193FK	Samples
7600601EA	ACTIVE	CDIP	J	16	1	TBD	A42	N / A for Pkg Type	-55 to 125	7600601EA SNJ54LS193J	Samples
7600601EA	ACTIVE	CDIP	J	16	1	TBD	A42	N / A for Pkg Type	-55 to 125	7600601EA SNJ54LS193J	Samples
7600601FA	ACTIVE	CFP	W	16	1	TBD	A42	N / A for Pkg Type	-55 to 125	7600601FA SNJ54LS193W	Samples
7600601FA	ACTIVE	CFP	W	16	1	TBD	A42	N / A for Pkg Type	-55 to 125	7600601FA SNJ54LS193W	Samples
JM38510/31508B2A	ACTIVE	LCCC	FK	20	1	TBD	POST-PLATE	N / A for Pkg Type	-55 to 125	JM38510/ 31508B2A	Samples
JM38510/31508B2A	ACTIVE	LCCC	FK	20	1	TBD	POST-PLATE	N / A for Pkg Type	-55 to 125	JM38510/ 31508B2A	Samples
JM38510/31508BEA	ACTIVE	CDIP	J	16	1	TBD	A42	N / A for Pkg Type	-55 to 125	JM38510/ 31508BEA	Samples
JM38510/31508BEA	ACTIVE	CDIP	J	16	1	TBD	A42	N / A for Pkg Type	-55 to 125	JM38510/ 31508BEA	Samples
JM38510/31508BFA	ACTIVE	CFP	W	16	1	TBD	A42	N / A for Pkg Type	-55 to 125	JM38510/ 31508BFA	Samples
JM38510/31508BFA	ACTIVE	CFP	W	16	1	TBD	A42	N / A for Pkg Type	-55 to 125	JM38510/ 31508BFA	Samples

Orderable Device	Status (1)	Package Type	Package Drawing	Pins	Package Qty	Eco Plan (2)	Lead/Ball Finish (6)	MSL Peak Temp (3)	Op Temp (°C)	Device Marking (4/5)	Samples
JM38510/31508SFA	ACTIVE	CFP	W	16	25	TBD	A42	N / A for Pkg Type	-55 to 125	JM38510/ 31508SFA	Samples
JM38510/31508SFA	ACTIVE	CFP	W	16	25	TBD	A42	N / A for Pkg Type	-55 to 125	JM38510/ 31508SFA	Samples
M38510/31508B2A	ACTIVE	LCCC	FK	20	1	TBD	POST-PLATE	N / A for Pkg Type	-55 to 125	JM38510/ 31508B2A	Samples
M38510/31508B2A	ACTIVE	LCCC	FK	20	1	TBD	POST-PLATE	N / A for Pkg Type	-55 to 125	JM38510/ 31508B2A	Samples
M38510/31508BEA	ACTIVE	CDIP	J	16	1	TBD	A42	N / A for Pkg Type	-55 to 125	JM38510/ 31508BEA	Samples
M38510/31508BEA	ACTIVE	CDIP	J	16	1	TBD	A42	N / A for Pkg Type	-55 to 125	JM38510/ 31508BEA	Samples
M38510/31508BFA	ACTIVE	CFP	W	16	1	TBD	A42	N / A for Pkg Type	-55 to 125	JM38510/ 31508BFA	Samples
M38510/31508BFA	ACTIVE	CFP	W	16	1	TBD	A42	N / A for Pkg Type	-55 to 125	JM38510/ 31508BFA	Samples
M38510/31508SFA	ACTIVE	CFP	W	16	25	TBD	A42	N / A for Pkg Type	-55 to 125	JM38510/ 31508SFA	Samples
M38510/31508SFA	ACTIVE	CFP	W	16	25	TBD	A42	N / A for Pkg Type	-55 to 125	JM38510/ 31508SFA	Samples
SN54192J	ACTIVE	CDIP	J	16	1	TBD	A42	N / A for Pkg Type	-55 to 125	SN54192J	Samples
SN54192J	ACTIVE	CDIP	J	16	1	TBD	A42	N / A for Pkg Type	-55 to 125	SN54192J	Samples
SN54LS193J	ACTIVE	CDIP	J	16	1	TBD	A42	N / A for Pkg Type	-55 to 125	SN54LS193J	Samples
SN54LS193J	ACTIVE	CDIP	J	16	1	TBD	A42	N / A for Pkg Type	-55 to 125	SN54LS193J	Samples
SN74LS193D	ACTIVE	SOIC	D	16	40	Green (RoHS & no Sb/Br)	CU NIPDAU	Level-1-260C-UNLIM	0 to 70	LS193	Samples
SN74LS193D	ACTIVE	SOIC	D	16	40	Green (RoHS & no Sb/Br)	CU NIPDAU	Level-1-260C-UNLIM	0 to 70	LS193	Samples
SN74LS193DR	ACTIVE	SOIC	D	16	2500	Green (RoHS & no Sb/Br)	CU NIPDAU	Level-1-260C-UNLIM	0 to 70	LS193	Samples
SN74LS193DR	ACTIVE	SOIC	D	16	2500	Green (RoHS & no Sb/Br)	CU NIPDAU	Level-1-260C-UNLIM	0 to 70	LS193	Samples

Orderable Device	Status (1)	Package Type	Package Drawing	Pins	Package Qty	Eco Plan (2)	Lead/Ball Finish (6)	MSL Peak Temp (3)	Op Temp (°C)	Device Marking (4/5)	Samples
SN74LS193N	ACTIVE	PDIP	N	16	25	Green (RoHS & no Sb/Br)	CU NIPDAU	N / A for Pkg Type	0 to 70	SN74LS193N	Samples
SN74LS193N	ACTIVE	PDIP	N	16	25	Green (RoHS & no Sb/Br)	CU NIPDAU	N / A for Pkg Type	0 to 70	SN74LS193N	Samples
SN74LS193NE4	ACTIVE	PDIP	N	16	25	Green (RoHS & no Sb/Br)	CU NIPDAU	N / A for Pkg Type	0 to 70	SN74LS193N	Samples
SN74LS193NE4	ACTIVE	PDIP	N	16	25	Green (RoHS & no Sb/Br)	CU NIPDAU	N / A for Pkg Type	0 to 70	SN74LS193N	Samples
SN74LS193NSR	ACTIVE	SO	NS	16	2000	Green (RoHS & no Sb/Br)	CU NIPDAU	Level-1-260C-UNLIM	0 to 70	74LS193	Samples
SN74LS193NSR	ACTIVE	SO	NS	16	2000	Green (RoHS & no Sb/Br)	CU NIPDAU	Level-1-260C-UNLIM	0 to 70	74LS193	Samples
SNJ54192J	ACTIVE	CDIP	J	16	1	TBD	A42	N / A for Pkg Type	-55 to 125	5962-9558401QE A SNJ54192J	Samples
SNJ54192J	ACTIVE	CDIP	J	16	1	TBD	A42	N / A for Pkg Type	-55 to 125	5962-9558401QE A SNJ54192J	Samples
SNJ54192W	ACTIVE	CFP	W	16	1	TBD	A42	N / A for Pkg Type	-55 to 125	5962-9558401QF A SNJ54192W	Samples
SNJ54192W	ACTIVE	CFP	W	16	1	TBD	A42	N / A for Pkg Type	-55 to 125	5962-9558401QF A SNJ54192W	Samples
SNJ54LS193FK	ACTIVE	LCCC	FK	20	1	TBD	POST-PLATE	N / A for Pkg Type	-55 to 125	76006012A SNJ54LS 193FK	Samples
SNJ54LS193FK	ACTIVE	LCCC	FK	20	1	TBD	POST-PLATE	N / A for Pkg Type	-55 to 125	76006012A SNJ54LS 193FK	Samples
SNJ54LS193J	ACTIVE	CDIP	J	16	1	TBD	A42	N / A for Pkg Type	-55 to 125	7600601EA SNJ54LS193J	Samples
SNJ54LS193J	ACTIVE	CDIP	J	16	1	TBD	A42	N / A for Pkg Type	-55 to 125	7600601EA SNJ54LS193J	Samples
SNJ54LS193W	ACTIVE	CFP	W	16	1	TBD	A42	N / A for Pkg Type	-55 to 125	7600601FA SNJ54LS193W	Samples

Orderable Device	Status (1)	Package Type	Package Drawing	Pins	Package Qty	Eco Plan (2)	Lead/Ball Finish (6)	MSL Peak Temp (3)	Op Temp (°C)	Device Marking (4/5)	Samples
SNJ54LS193W	ACTIVE	CFP	W	16	1	TBD	A42	N / A for Pkg Type	-55 to 125	7600601FA SNJ54LS193W	Samples

(1) The marketing status values are defined as follows:

ACTIVE: Product device recommended for new designs.

LIFEBUY: TI has announced that the device will be discontinued, and a lifetime-buy period is in effect.

NRND: Not recommended for new designs. Device is in production to support existing customers, but TI does not recommend using this part in a new design.

PREVIEW: Device has been announced but is not in production. Samples may or may not be available.

OBSOLETE: TI has discontinued the production of the device.

(2) **RoHS:** TI defines "RoHS" to mean semiconductor products that are compliant with the current EU RoHS requirements for all 10 RoHS substances, including the requirement that RoHS substance do not exceed 0.1% by weight in homogeneous materials. Where designed to be soldered at high temperatures, "RoHS" products are suitable for use in specified lead-free processes. TI may reference these types of products as "Pb-Free".

RoHS Exempt: TI defines "RoHS Exempt" to mean products that contain lead but are compliant with EU RoHS pursuant to a specific EU RoHS exemption.

Green: TI defines "Green" to mean the content of Chlorine (Cl) and Bromine (Br) based flame retardants meet JS709B low halogen requirements of <=1000ppm threshold. Antimony trioxide based flame retardants must also meet the <=1000ppm threshold requirement.

(3) MSL, Peak Temp. - The Moisture Sensitivity Level rating according to the JEDEC industry standard classifications, and peak solder temperature.

(4) There may be additional marking, which relates to the logo, the lot trace code information, or the environmental category on the device.

(5) Multiple Device Markings will be inside parentheses. Only one Device Marking contained in parentheses and separated by a "~" will appear on a device. If a line is indented then it is a continuation of the previous line and the two combined represent the entire Device Marking for that device.

(6) Lead/Ball Finish - Orderable Devices may have multiple material finish options. Finish options are separated by a vertical ruled line. Lead/Ball Finish values may wrap to two lines if the finish value exceeds the maximum column width.

Important Information and Disclaimer:The information provided on this page represents TI's knowledge and belief as of the date that it is provided. TI bases its knowledge and belief on information provided by third parties, and makes no representation or warranty as to the accuracy of such information. Efforts are underway to better integrate information from third parties. TI has taken and continues to take reasonable steps to provide representative and accurate information but may not have conducted destructive testing or chemical analysis on incoming materials and chemicals. TI and TI suppliers consider certain information to be proprietary, and thus CAS numbers and other limited information may not be available for release.

In no event shall TI's liability arising out of such information exceed the total purchase price of the TI part(s) at issue in this document sold by TI to Customer on an annual basis.

OTHER QUALIFIED VERSIONS OF SN54LS193, SN54LS193-SP, SN74LS193 :

- Catalog: [SN74LS193](#), [SN54LS193](#)

- Military: [SN54LS193](#)
- Space: [SN54LS193-SP](#)

NOTE: Qualified Version Definitions:

- Catalog - TI's standard catalog product
- Military - QML certified for Military and Defense Applications
- Space - Radiation tolerant, ceramic packaging and qualified for use in Space-based application

TAPE AND REEL INFORMATION

REEL DIMENSIONS

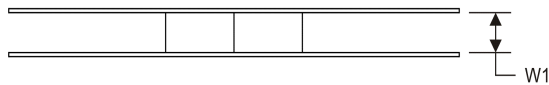
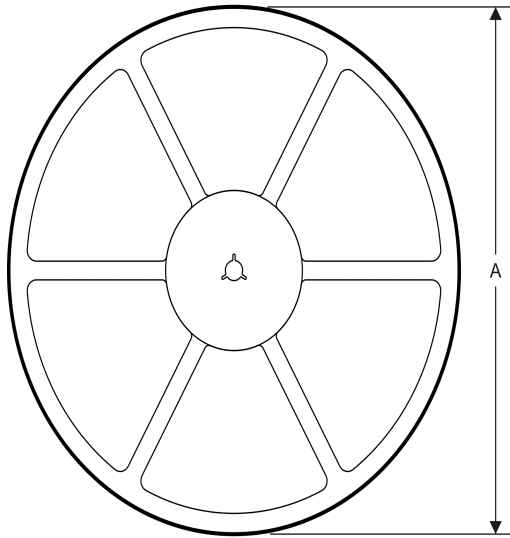

TAPE DIMENSIONS

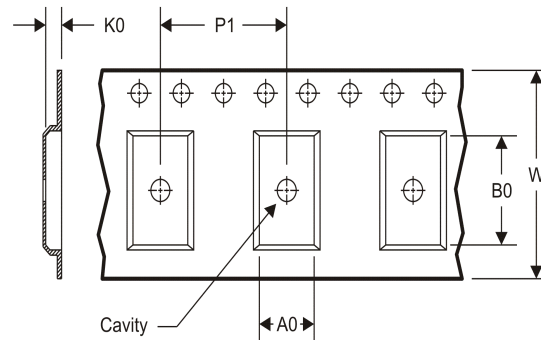

A0	Dimension designed to accommodate the component width
B0	Dimension designed to accommodate the component length
K0	Dimension designed to accommodate the component thickness
W	Overall width of the carrier tape
P1	Pitch between successive cavity centers

TAPE AND REEL INFORMATION

*All dimensions are nominal

Device	Package Type	Package Drawing	Pins	SPQ	Reel Diameter (mm)	Reel Width W1 (mm)	A0 (mm)	B0 (mm)	K0 (mm)	P1 (mm)	W (mm)	Pin1 Quadrant
SN74LS193DR	SOIC	D	16	2500	330.0	16.4	6.5	10.3	2.1	8.0	16.0	Q1
SN74LS193NSR	SO	NS	16	2000	330.0	16.4	8.2	10.5	2.5	12.0	16.0	Q1

TAPE AND REEL BOX DIMENSIONS



*All dimensions are nominal

Device	Package Type	Package Drawing	Pins	SPQ	Length (mm)	Width (mm)	Height (mm)
SN74LS193DR	SOIC	D	16	2500	333.2	345.9	28.6
SN74LS193NSR	SO	NS	16	2000	367.0	367.0	38.0

FK (S-CQCC-N**)

LEADLESS CERAMIC CHIP CARRIER

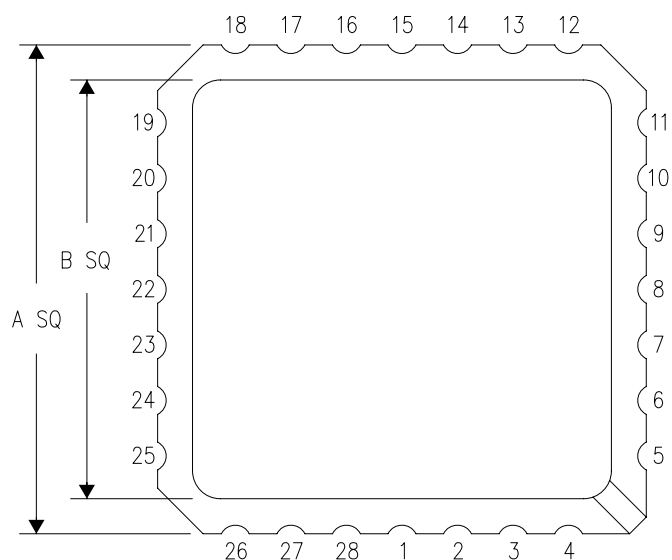
28 TERMINAL SHOWN



NO. OF TERMINALS **	A		B	
	MIN	MAX	MIN	MAX
20	0.342 (8,69)	0.358 (9,09)	0.307 (7,80)	0.358 (9,09)
28	0.442 (11,23)	0.458 (11,63)	0.406 (10,31)	0.458 (11,63)
44	0.640 (16,26)	0.660 (16,76)	0.495 (12,58)	0.560 (14,22)
52	0.740 (18,78)	0.761 (19,32)	0.495 (12,58)	0.560 (14,22)
68	0.938 (23,83)	0.962 (24,43)	0.850 (21,6)	0.858 (21,8)
84	1.141 (28,99)	1.165 (29,59)	1.047 (26,6)	1.063 (27,0)

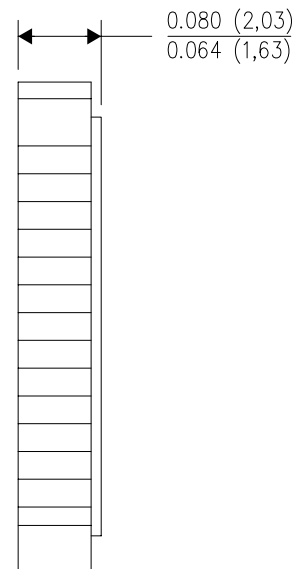
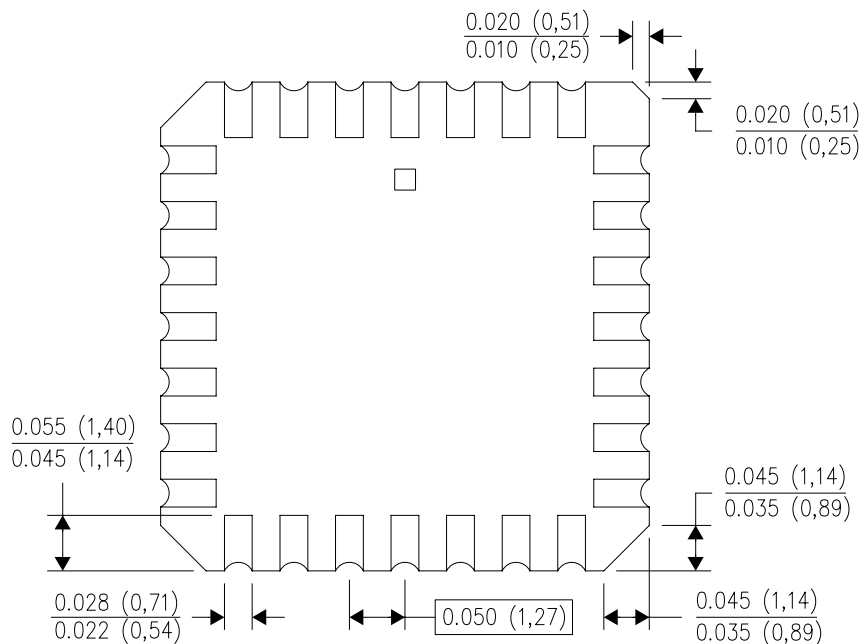

4040140/D 01/11

- NOTES:
- All linear dimensions are in inches (millimeters).
 - This drawing is subject to change without notice.
 - This package can be hermetically sealed with a metal lid.
 - Falls within JEDEC MS-004

D (R-PDSO-G16)

PLASTIC SMALL OUTLINE



- NOTES:
- All linear dimensions are in millimeters.
 - This drawing is subject to change without notice.
 - Publication IPC-7351 is recommended for alternate designs.
 - Laser cutting apertures with trapezoidal walls and also rounding corners will offer better paste release. Customers should contact their board assembly site for stencil design recommendations. Refer to IPC-7525 for other stencil recommendations.
 - Customers should contact their board fabrication site for solder mask tolerances between and around signal pads.

MECHANICAL DATA

NS (R-PDSO-G**)

PLASTIC SMALL-OUTLINE PACKAGE

14-PINS SHOWN



- NOTES:
- A. All linear dimensions are in millimeters.
 - B. This drawing is subject to change without notice.
 - C. Body dimensions do not include mold flash or protrusion, not to exceed 0,15.

W (R-GDFP-F16)

CERAMIC DUAL FLATPACK



- NOTES:
- A. All linear dimensions are in inches (millimeters).
 - B. This drawing is subject to change without notice.
 - C. This package can be hermetically sealed with a ceramic lid using glass frit.
 - D. Index point is provided on cap for terminal identification only.
 - E. Falls within MIL STD 1835 GDFP2-F16

J (R-GDIP-T**)

14 LEADS SHOWN

CERAMIC DUAL IN-LINE PACKAGE



DIM \ PINS **	14	16	18	20
A	0.300 (7,62) BSC	0.300 (7,62) BSC	0.300 (7,62) BSC	0.300 (7,62) BSC
B MAX	0.785 (19,94)	.840 (21,34)	0.960 (24,38)	1.060 (26,92)
B MIN	—	—	—	—
C MAX	0.300 (7,62)	0.300 (7,62)	0.310 (7,87)	0.300 (7,62)
C MIN	0.245 (6,22)	0.245 (6,22)	0.220 (5,59)	0.245 (6,22)



4040083/F 03/03

- NOTES:
- A. All linear dimensions are in inches (millimeters).
 - B. This drawing is subject to change without notice.
 - C. This package is hermetically sealed with a ceramic lid using glass frit.
 - D. Index point is provided on cap for terminal identification only on press ceramic glass frit seal only.
 - E. Falls within MIL STD 1835 GDIP1-T14, GDIP1-T16, GDIP1-T18 and GDIP1-T20.

N (R-PDIP-T**)

PLASTIC DUAL-IN-LINE PACKAGE

16 PINS SHOWN



4040049/E 12/2002

- NOTES:
- A. All linear dimensions are in inches (millimeters).
 - B. This drawing is subject to change without notice.
 - (C) Falls within JEDEC MS-001, except 18 and 20 pin minimum body length (Dim A).
 - (D) The 20 pin end lead shoulder width is a vendor option, either half or full width.

IMPORTANT NOTICE

Texas Instruments Incorporated (TI) reserves the right to make corrections, enhancements, improvements and other changes to its semiconductor products and services per JESD46, latest issue, and to discontinue any product or service per JESD48, latest issue. Buyers should obtain the latest relevant information before placing orders and should verify that such information is current and complete.

TI's published terms of sale for semiconductor products (<http://www.ti.com/sc/docs/stdterms.htm>) apply to the sale of packaged integrated circuit products that TI has qualified and released to market. Additional terms may apply to the use or sale of other types of TI products and services.

Reproduction of significant portions of TI information in TI data sheets is permissible only if reproduction is without alteration and is accompanied by all associated warranties, conditions, limitations, and notices. TI is not responsible or liable for such reproduced documentation. Information of third parties may be subject to additional restrictions. Resale of TI products or services with statements different from or beyond the parameters stated by TI for that product or service voids all express and any implied warranties for the associated TI product or service and is an unfair and deceptive business practice. TI is not responsible or liable for any such statements.

Buyers and others who are developing systems that incorporate TI products (collectively, "Designers") understand and agree that Designers remain responsible for using their independent analysis, evaluation and judgment in designing their applications and that Designers have full and exclusive responsibility to assure the safety of Designers' applications and compliance of their applications (and of all TI products used in or for Designers' applications) with all applicable regulations, laws and other applicable requirements. Designer represents that, with respect to their applications, Designer has all the necessary expertise to create and implement safeguards that (1) anticipate dangerous consequences of failures, (2) monitor failures and their consequences, and (3) lessen the likelihood of failures that might cause harm and take appropriate actions. Designer agrees that prior to using or distributing any applications that include TI products, Designer will thoroughly test such applications and the functionality of such TI products as used in such applications.

TI's provision of technical, application or other design advice, quality characterization, reliability data or other services or information, including, but not limited to, reference designs and materials relating to evaluation modules, (collectively, "TI Resources") are intended to assist designers who are developing applications that incorporate TI products; by downloading, accessing or using TI Resources in any way, Designer (individually or, if Designer is acting on behalf of a company, Designer's company) agrees to use any particular TI Resource solely for this purpose and subject to the terms of this Notice.

TI's provision of TI Resources does not expand or otherwise alter TI's applicable published warranties or warranty disclaimers for TI products, and no additional obligations or liabilities arise from TI providing such TI Resources. TI reserves the right to make corrections, enhancements, improvements and other changes to its TI Resources. TI has not conducted any testing other than that specifically described in the published documentation for a particular TI Resource.

Designer is authorized to use, copy and modify any individual TI Resource only in connection with the development of applications that include the TI product(s) identified in such TI Resource. NO OTHER LICENSE, EXPRESS OR IMPLIED, BY ESTOPPEL OR OTHERWISE TO ANY OTHER TI INTELLECTUAL PROPERTY RIGHT, AND NO LICENSE TO ANY TECHNOLOGY OR INTELLECTUAL PROPERTY RIGHT OF TI OR ANY THIRD PARTY IS GRANTED HEREIN, including but not limited to any patent right, copyright, mask work right, or other intellectual property right relating to any combination, machine, or process in which TI products or services are used. Information regarding or referencing third-party products or services does not constitute a license to use such products or services, or a warranty or endorsement thereof. Use of TI Resources may require a license from a third party under the patents or other intellectual property of the third party, or a license from TI under the patents or other intellectual property of TI.

TI RESOURCES ARE PROVIDED "AS IS" AND WITH ALL FAULTS. TI DISCLAIMS ALL OTHER WARRANTIES OR REPRESENTATIONS, EXPRESS OR IMPLIED, REGARDING RESOURCES OR USE THEREOF, INCLUDING BUT NOT LIMITED TO ACCURACY OR COMPLETENESS, TITLE, ANY EPIDEMIC FAILURE WARRANTY AND ANY IMPLIED WARRANTIES OF MERCHANTABILITY, FITNESS FOR A PARTICULAR PURPOSE, AND NON-INFRINGEMENT OF ANY THIRD PARTY INTELLECTUAL PROPERTY RIGHTS. TI SHALL NOT BE LIABLE FOR AND SHALL NOT DEFEND OR INDEMNIFY DESIGNER AGAINST ANY CLAIM, INCLUDING BUT NOT LIMITED TO ANY INFRINGEMENT CLAIM THAT RELATES TO OR IS BASED ON ANY COMBINATION OF PRODUCTS EVEN IF DESCRIBED IN TI RESOURCES OR OTHERWISE. IN NO EVENT SHALL TI BE LIABLE FOR ANY ACTUAL, DIRECT, SPECIAL, COLLATERAL, INDIRECT, PUNITIVE, INCIDENTAL, CONSEQUENTIAL OR EXEMPLARY DAMAGES IN CONNECTION WITH OR ARISING OUT OF TI RESOURCES OR USE THEREOF, AND REGARDLESS OF WHETHER TI HAS BEEN ADVISED OF THE POSSIBILITY OF SUCH DAMAGES.

Unless TI has explicitly designated an individual product as meeting the requirements of a particular industry standard (e.g., ISO/TS 16949 and ISO 26262), TI is not responsible for any failure to meet such industry standard requirements.



Where TI specifically promotes products as facilitating functional safety or as compliant with industry functional safety standards, such products are intended to help enable customers to design and create their own applications that meet applicable functional safety standards and requirements. Using products in an application does not by itself establish any safety features in the application. Designers must ensure compliance with safety-related requirements and standards applicable to their applications. Designer may not use any TI products in life-critical medical equipment unless authorized officers of the parties have executed a special contract specifically governing such use. Life-critical medical equipment is medical equipment where failure of such equipment would cause serious bodily injury or death (e.g., life support, pacemakers, defibrillators, heart pumps, neurostimulators, and implantables). Such equipment includes, without limitation, all medical devices identified by the U.S. Food and Drug Administration as Class III devices and equivalent classifications outside the U.S.

TI may expressly designate certain products as completing a particular qualification (e.g., Q100, Military Grade, or Enhanced Product). Designers agree that it has the necessary expertise to select the product with the appropriate qualification designation for their applications and that proper product selection is at Designers' own risk. Designers are solely responsible for compliance with all legal and regulatory requirements in connection with such selection.

Designer will fully indemnify TI and its representatives against any damages, costs, losses, and/or liabilities arising out of Designer's non-compliance with the terms and provisions of this Notice.

Looking for pricing, stock, or lifecycle information?

Click below to explore more details on WIN SOURCE:

-  [View SN74LS193N on WIN SOURCE](#)
-  [Texas Instruments](#) Information

Optimize Your Supply Chain with WIN SOURCE Solutions

-  Global Sourcing Solution
-  Obsolete Management
-  Cost Control Management
-  Shortage Management
-  Alternative Solution
-  Excess Inventory Management