



**THE DATASHEET OF
74HC40103D,653**



74HC40103

8-bit synchronous binary down counter

Rev. 5 — 21 April 2016

Product data sheet

1. General description

The 74HC40103 is an 8-bit synchronous down counter. It has control inputs for enabling or disabling the clock (CP), for clearing the counter to its maximum count and for presetting the counter either synchronously or asynchronously. In normal operation, the counter is decremented by one count on each positive-going transition of the clock (CP). Counting is inhibited when the terminal enable input (\overline{TE}) is HIGH. The terminal count output (\overline{TC}) goes LOW when the count reaches zero if \overline{TE} is LOW, and remains LOW for one full clock period. When the synchronous preset enable input (\overline{PE}) is LOW, data at the jam input (P0 to P7) is clocked into the counter on the next positive-going clock transition regardless of the state of \overline{TE} . When the asynchronous preset enable input (\overline{PL}) is LOW, data at the jam input (P0 to P7) is asynchronously forced into the counter regardless of the state of \overline{PE} , \overline{TE} , or CP. The jam inputs (P0 to P7) represent a single 8-bit binary word. When the master reset input (\overline{MR}) is LOW, the counter is asynchronously cleared to its maximum count (decimal 255) regardless of the state of any other input. If all control inputs except \overline{TE} are HIGH at the time of zero count, the counters will jump to the maximum count, giving a counting sequence of 256 clock pulses long. Device may be cascaded using the \overline{TE} input and the TC output, in either a synchronous or ripple mode. Inputs include clamp diodes. This enables the use of current limiting resistors to interface inputs to voltages in excess of V_{CC} .

2. Features and benefits

- Cascadable
- Synchronous or asynchronous preset
- Low-power dissipation
- Complies with JEDEC standard no. 7A
- CMOS input levels
- ESD protection:
 - ◆ HBM JESD22-A114F exceeds 2000 V
 - ◆ MM JESD22-A115-A exceeds 200 V
- Multiple package options
- Specified from $-40\text{ }^{\circ}\text{C}$ to $+80\text{ }^{\circ}\text{C}$ and from $-40\text{ }^{\circ}\text{C}$ to $+125\text{ }^{\circ}\text{C}$

3. Applications

- Divide-by-n counters
- Programmable timers
- Interrupt timers
- Cycle/program counters.

4. Ordering information

Table 1. Ordering information

Type number	Package			Version
	Temperature range	Name	Description	
74HC40103D	-40 °C to +125 °C	SO16	plastic small outline package; 16 leads; body width 3.9 mm	SOT109-1
74HC40103PW	-40 °C to +125 °C	TSSOP16	plastic thin shrink small outline package; 16 leads; body width 4.4 mm	SOT403-1

5. Functional diagram

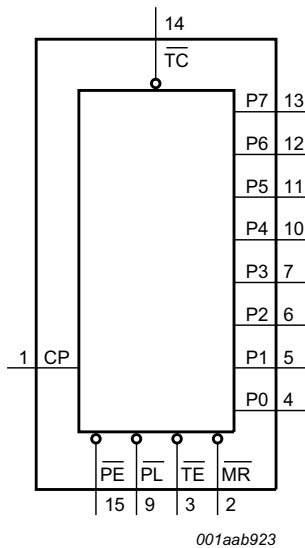

Fig 1. Functional diagram

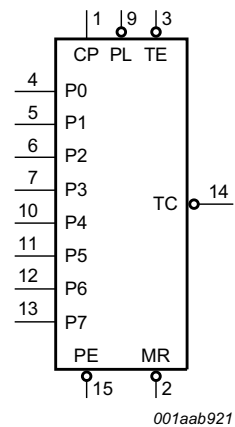

Fig 2. Logic symbol

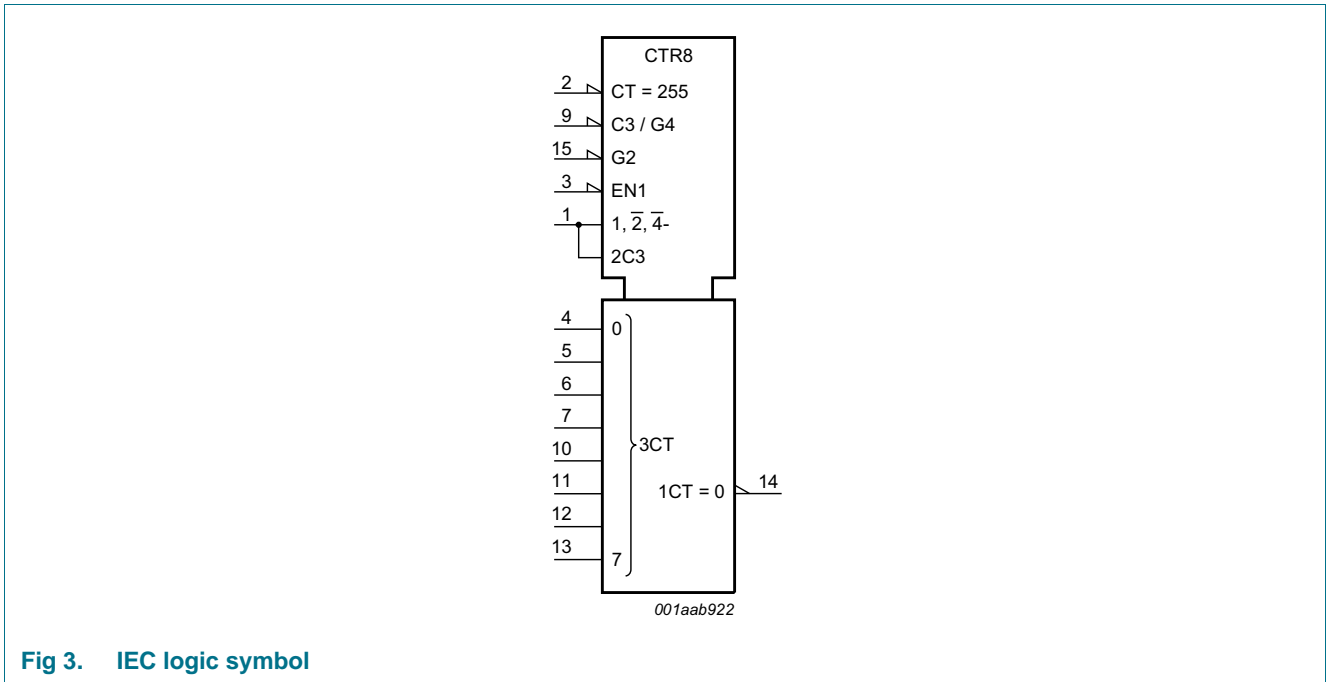

Fig 3. IEC logic symbol

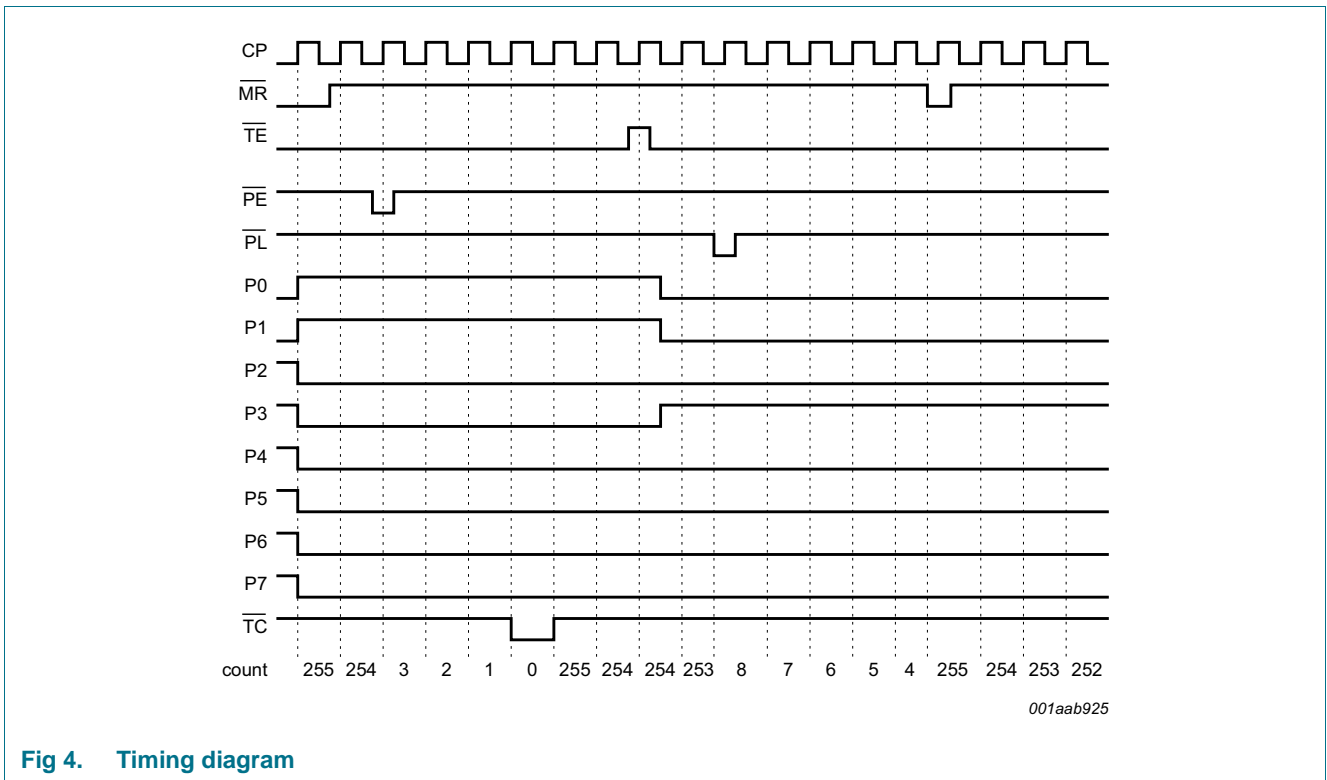

Fig 4. Timing diagram

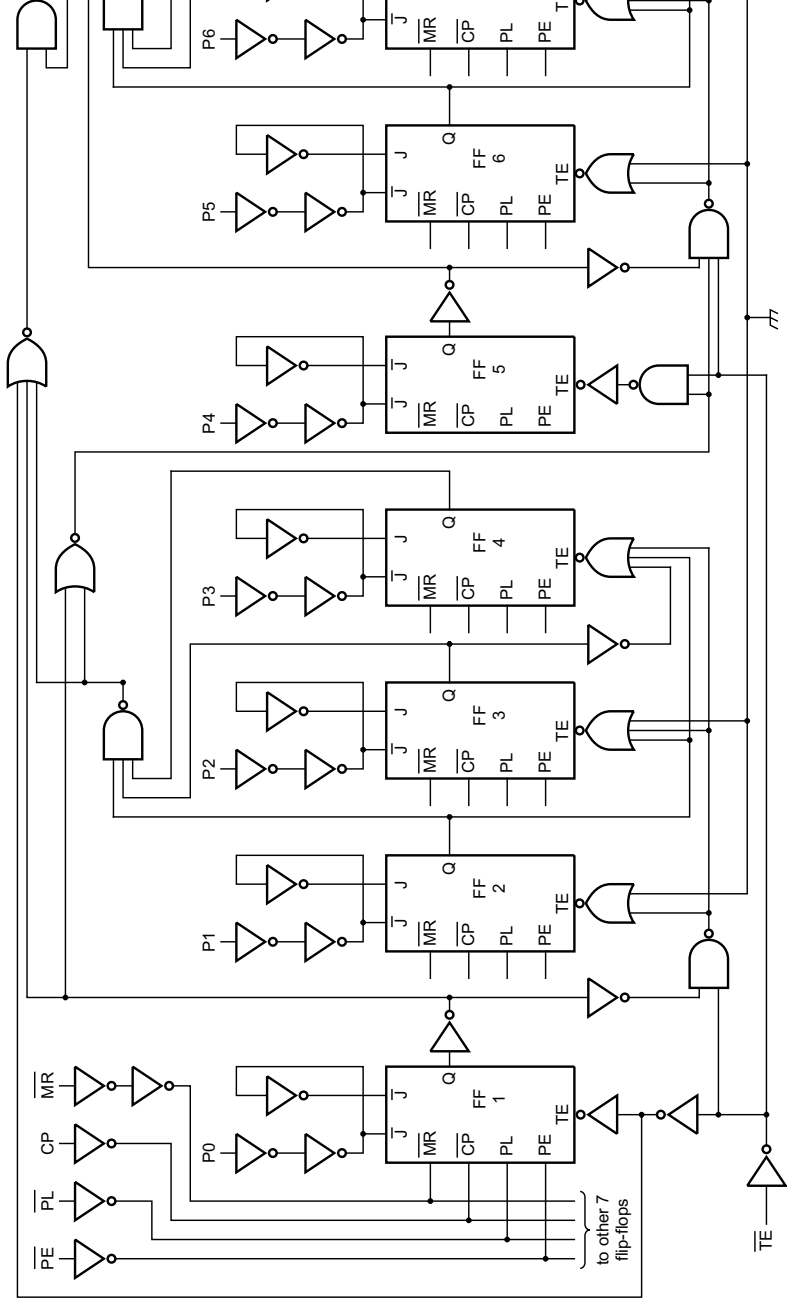

Fig 5. Logic diagram

6. Pinning information

6.1 Pinning

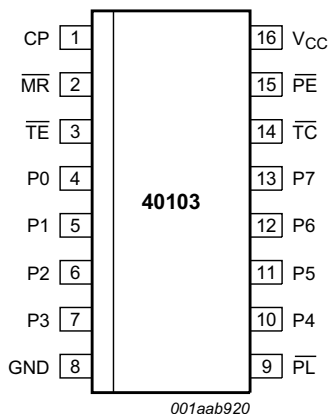

Fig 6. Pin configuration

6.2 Pin description

Table 2. Pin description

Symbol	Pin	Description
CP	1	clock input (LOW-to-HIGH, edge-triggered)
$\overline{\text{MR}}$	2	asynchronous master reset input (active LOW)
$\overline{\text{TE}}$	3	terminal enable input (active LOW)
P0	4	jam input 0
P1	5	jam input 1
P2	6	jam input 2
P3	7	jam input 3
GND	8	ground (0 V)
$\overline{\text{PL}}$	9	asynchronous preset enable input (active LOW)
P4	10	jam input 4
P5	11	jam input 5
P6	12	jam input 6
P7	13	jam input 7
$\overline{\text{TC}}$	14	terminal count output (active LOW)
$\overline{\text{PE}}$	15	synchronous preset enable input (active LOW)
V _{CC}	16	positive supply voltage

7. Functional description

7.1 Function table

Table 3. Function table^[1]

Control inputs				Preset mode	Action ^[2]
MR	PL	PE	TE		
L	X	X	X	asynchronous	clear to maximum count
H	L	X	X	asynchronous	preset asynchronously
		H	L	X	synchronous
	H	L	L	synchronous	count down
		H	H	synchronous	inhibit counter

[1] H = HIGH voltage level;
L = LOW voltage level;
X = don't care.

[2] Clock connected to CP.
Synchronous operation: changes occur on the LOW-to-HIGH CP transition.
Jam inputs: MSD = P7, LSD = P0.

8. Limiting values

Table 4. Limiting values

In accordance with the Absolute Maximum Rating System (IEC 60134). Voltages are referenced to GND (ground = 0 V).

Symbol	Parameter	Conditions	Min	Max	Unit
V_{CC}	supply voltage		-0.5	+7	V
I_{IK}	input clamping current	$V_I < -0.5\text{ V}$ or $V_I > V_{CC} + 0.5\text{ V}$ ^[1]	-	±20	mA
I_{OK}	output clamping current	$V_O < -0.5\text{ V}$ or $V_O > V_{CC} + 0.5\text{ V}$ ^[1]	-	±20	mA
I_O	output current	$V_O = -0.5\text{ V}$ to $V_{CC} + 0.5\text{ V}$	-	±25	mA
I_{CC}	supply current		-	+50	mA
I_{GND}	ground current		-50	-	mA
T_{stg}	storage temperature		-65	+150	°C
P_{tot}	total power dissipation	SO16 package ^[2]	-	500	mW
		TSSOP16 packages ^[3]	-	500	mW

[1] The input and output voltage ratings may be exceeded if the input and output current ratings are observed.

[2] For SO16 package: above 70 °C, P_{tot} derates linearly with 8 mW/K.

[3] For TSSOP16 package: above 60 °C, P_{tot} derates linearly with 5.5 mW/K.

9. Recommended operating conditions

Table 5. Recommended operating conditions

Symbol	Parameter	Conditions	Min	Typ	Max	Unit
V_{CC}	supply voltage		2.0	5.0	6.0	V
V_I	input voltage		0	-	V_{CC}	V
V_O	output voltage		0	-	V_{CC}	V
$\Delta t/\Delta V$	input transition rise and fall rates	$V_{CC} = 2.0\text{ V}$	-	-	625	ns
		$V_{CC} = 4.5\text{ V}$	-	1.67	139	ns
		$V_{CC} = 6.0\text{ V}$	-	-	83	ns
T_{amb}	ambient temperature		-40	-	+125	°C

10. Static characteristics

Table 6. Static characteristics

At recommended operating conditions; voltages are referenced to GND (ground = 0 V).

Symbol	Parameter	Conditions	Min	Typ	Max	Unit
$T_{amb} = 25\text{ °C}$						
V_{IH}	HIGH-level input voltage	$V_{CC} = 2.0\text{ V}$	1.5	1.2	-	V
		$V_{CC} = 4.5\text{ V}$	3.15	2.4	-	V
		$V_{CC} = 6.0\text{ V}$	4.2	3.2	-	V
V_{IL}	LOW-level input voltage	$V_{CC} = 2.0\text{ V}$	-	0.8	0.5	V
		$V_{CC} = 4.5\text{ V}$	-	2.1	1.35	V
		$V_{CC} = 6.0\text{ V}$	-	2.8	1.8	V
V_{OH}	HIGH-level output voltage	$V_I = V_{IH}$ or V_{IL}				
		$I_O = -20\text{ }\mu\text{A}$; $V_{CC} = 2.0\text{ V}$	1.9	2.0	-	V
		$I_O = -20\text{ }\mu\text{A}$; $V_{CC} = 4.5\text{ V}$	4.4	4.5	-	V
		$I_O = -20\text{ }\mu\text{A}$; $V_{CC} = 6.0\text{ V}$	5.9	6.0	-	V
		$I_O = -4\text{ mA}$; $V_{CC} = 4.5\text{ V}$	3.98	4.32	-	V
V_{OL}	LOW-level output voltage	$V_I = V_{IH}$ or V_{IL}				
		$I_O = 20\text{ }\mu\text{A}$; $V_{CC} = 2.0\text{ V}$	-	0	0.1	V
		$I_O = 20\text{ }\mu\text{A}$; $V_{CC} = 4.5\text{ V}$	-	0	0.1	V
		$I_O = 20\text{ }\mu\text{A}$; $V_{CC} = 6.0\text{ V}$	-	0	0.1	V
		$I_O = 4\text{ mA}$; $V_{CC} = 4.5\text{ V}$	-	0.15	0.26	V
		$I_O = 5.2\text{ mA}$; $V_{CC} = 6.0\text{ V}$	-	0.16	0.26	V
I_I	input leakage current	$V_I = V_{CC}$ or GND; $V_{CC} = 6.0\text{ V}$	-	-	± 0.1	μA
I_{CC}	supply current	$V_I = V_{CC}$ or GND; $I_O = 0\text{ A}$; $V_{CC} = 6.0\text{ V}$	-	-	8.0	μA
C_I	input capacitance		-	3.5	-	pF

Table 6. Static characteristics ...continued

At recommended operating conditions; voltages are referenced to GND (ground = 0 V).

Symbol	Parameter	Conditions	Min	Typ	Max	Unit
T_{amb} = -40 °C to +85 °C						
V _{IH}	HIGH-level input voltage	V _{CC} = 2.0 V	1.5	-	-	V
		V _{CC} = 4.5 V	3.15	-	-	V
		V _{CC} = 6.0 V	4.2	-	-	V
V _{IL}	LOW-level input voltage	V _{CC} = 2.0 V	-	-	0.5	V
		V _{CC} = 4.5 V	-	-	1.35	V
		V _{CC} = 6.0 V	-	-	1.8	V
V _{OH}	HIGH-level output voltage	V _I = V _{IH} or V _{IL}				
		I _O = -20 μA; V _{CC} = 2.0 V	1.9	-	-	V
		I _O = -20 μA; V _{CC} = 4.5 V	4.4	-	-	V
		I _O = -20 μA; V _{CC} = 6.0 V	5.9	-	-	V
		I _O = -4 mA; V _{CC} = 4.5 V	3.84	-	-	V
		I _O = -5.2 mA; V _{CC} = 6.0 V	5.34	-	-	V
V _{OL}	LOW-level output voltage	V _I = V _{IH} or V _{IL}				
		I _O = 20 μA; V _{CC} = 2.0 V	-	-	0.1	V
		I _O = 20 μA; V _{CC} = 4.5 V	-	-	0.1	V
		I _O = 20 μA; V _{CC} = 6.0 V	-	-	0.1	V
		I _O = 4 mA; V _{CC} = 4.5 V	-	-	0.33	V
		I _O = 5.2 mA; V _{CC} = 6.0 V	-	-	0.33	V
I _I	input leakage current	V _I = V _{CC} or GND; V _{CC} = 6.0 V	-	-	±1.0	μA
I _{CC}	supply current	V _I = V _{CC} or GND; I _O = 0 A; V _{CC} = 6.0 V	-	-	80	μA
T_{amb} = -40 °C to +125 °C						
V _{IH}	HIGH-level input voltage	V _{CC} = 2.0 V	1.5	-	-	V
		V _{CC} = 4.5 V	3.15	-	-	V
		V _{CC} = 6.0 V	4.2	-	-	V
V _{IL}	LOW-level input voltage	V _{CC} = 2.0 V	-	-	0.5	V
		V _{CC} = 4.5 V	-	-	1.35	V
		V _{CC} = 6.0 V	-	-	1.8	V
V _{OH}	HIGH-level output voltage	V _I = V _{IH} or V _{IL}				
		I _O = -20 μA; V _{CC} = 2.0 V	1.9	-	-	V
		I _O = -20 μA; V _{CC} = 4.5 V	4.4	-	-	V
		I _O = -20 μA; V _{CC} = 6.0 V	5.9	-	-	V
		I _O = -4 mA; V _{CC} = 4.5 V	3.7	-	-	V
		I _O = -5.2 mA; V _{CC} = 6.0 V	5.2	-	-	V

Table 6. Static characteristics ...continued

At recommended operating conditions; voltages are referenced to GND (ground = 0 V).

Symbol	Parameter	Conditions	Min	Typ	Max	Unit
V _{OL}	LOW-level output voltage	V _I = V _{IH} or V _{IL}				
		I _O = 20 μA; V _{CC} = 2.0 V	-	-	0.1	V
		I _O = 20 μA; V _{CC} = 4.5 V	-	-	0.1	V
		I _O = 20 μA; V _{CC} = 6.0 V	-	-	0.1	V
		I _O = 4 mA; V _{CC} = 4.5 V	-	-	0.4	V
		I _O = 5.2 mA; V _{CC} = 6.0 V	-	-	0.4	V
I _I	input leakage current	V _I = V _{CC} or GND; V _{CC} = 6.0 V	-	-	±1.0	μA
I _{CC}	supply current	V _I = V _{CC} or GND; I _O = 0 A; V _{CC} = 6.0 V	-	-	160	μA

11. Dynamic characteristics

Table 7. Dynamic characteristicsGND = 0 V; t_r = t_f = 6 ns; C_L = 50 pF; see [Figure 13](#).

Symbol	Parameter	Conditions	Min	Typ	Max	Unit
T_{amb} = 25 °C						
t _{pd}	propagation delay	CP to $\overline{\text{TC}}$; see Figure 7 [1]				
		V _{CC} = 2.0 V	-	96	300	ns
		V _{CC} = 4.5 V	-	35	60	ns
		V _{CC} = 6.0 V	-	28	51	ns
		V _{CC} = 5.0 V; C _L = 15 pF	-	30	-	ns
		$\overline{\text{TE}}$ to $\overline{\text{TC}}$; see Figure 8				
		V _{CC} = 2.0 V	-	50	175	ns
		V _{CC} = 4.5 V	-	18	35	ns
		V _{CC} = 6.0 V	-	14	30	ns
		$\overline{\text{PL}}$ to $\overline{\text{TC}}$; see Figure 9				
		V _{CC} = 2.0 V	-	102	315	ns
		V _{CC} = 4.5 V	-	37	63	ns
		V _{CC} = 6.0 V	-	30	53	ns
t _{PHL}	HIGH to LOW propagation delay	$\overline{\text{MR}}$ to $\overline{\text{TC}}$; see Figure 9				
		V _{CC} = 2.0 V	-	83	275	ns
		V _{CC} = 4.5 V	-	30	55	ns
		V _{CC} = 6.0 V	-	24	47	ns
t _t	transition time	see Figure 8 [2]				
		V _{CC} = 2.0 V	-	19	75	ns
		V _{CC} = 4.5 V	-	7	15	ns
		V _{CC} = 6.0 V	-	6	13	ns

Table 7. Dynamic characteristics ...continued
 $GND = 0\text{ V}$; $t_r = t_f = 6\text{ ns}$; $C_L = 50\text{ pF}$; see [Figure 13](#).

Symbol	Parameter	Conditions	Min	Typ	Max	Unit
t_w	pulse width	CP HIGH or LOW; see Figure 7				
		$V_{CC} = 2.0\text{ V}$	165	22	-	ns
		$V_{CC} = 4.5\text{ V}$	33	8	-	ns
		$V_{CC} = 6.0\text{ V}$	28	6	-	ns
		$\overline{\text{MR}}$ LOW; see Figure 9				
		$V_{CC} = 2.0\text{ V}$	125	39	-	ns
		$V_{CC} = 4.5\text{ V}$	25	14	-	ns
		$V_{CC} = 6.0\text{ V}$	21	11	-	ns
		$\overline{\text{PL}}$ LOW; see Figure 9				
		$V_{CC} = 2.0\text{ V}$	125	33	-	ns
		$V_{CC} = 4.5\text{ V}$	25	12	-	ns
		$V_{CC} = 6.0\text{ V}$	21	10	-	ns
t_{rec}	recovery time	$\overline{\text{MR}}$ to CP, $\overline{\text{PL}}$ to CP; see Figure 10				
		$V_{CC} = 2.0\text{ V}$	50	14	-	ns
		$V_{CC} = 4.5\text{ V}$	10	5	-	ns
		$V_{CC} = 6.0\text{ V}$	9	4	-	ns
t_{su}	set-up time	$\overline{\text{PE}}$ to CP; see Figure 11				
		$V_{CC} = 2.0\text{ V}$	75	22	-	ns
		$V_{CC} = 4.5\text{ V}$	15	8	-	ns
		$V_{CC} = 6.0\text{ V}$	13	6	-	ns
		$\overline{\text{TE}}$ to CP; see Figure 12				
		$V_{CC} = 2.0\text{ V}$	150	44	-	ns
		$V_{CC} = 4.5\text{ V}$	30	16	-	ns
		$V_{CC} = 6.0\text{ V}$	26	13	-	ns
		Pn to CP; see Figure 11				
		$V_{CC} = 2.0\text{ V}$	75	22	-	ns
		$V_{CC} = 4.5\text{ V}$	15	8	-	ns
		$V_{CC} = 6.0\text{ V}$	13	6	-	ns
t_h	hold time	$\overline{\text{PE}}$ to CP; see Figure 11				
		$V_{CC} = 2.0\text{ V}$	0	-14	-	ns
		$V_{CC} = 4.5\text{ V}$	0	-5	-	ns
		$V_{CC} = 6.0\text{ V}$	0	-4	-	ns
		$\overline{\text{TE}}$ to CP; see Figure 12				
		$V_{CC} = 2.0\text{ V}$	0	-30	-	ns
		$V_{CC} = 4.5\text{ V}$	0	-11	-	ns
		$V_{CC} = 6.0\text{ V}$	0	-9	-	ns
		Pn to CP; see Figure 11				
		$V_{CC} = 2.0\text{ V}$	0	-17	-	ns
		$V_{CC} = 4.5\text{ V}$	0	-6	-	ns
		$V_{CC} = 6.0\text{ V}$	0	-5	-	ns

Table 7. Dynamic characteristics ...continued
 $GND = 0\text{ V}$; $t_r = t_f = 6\text{ ns}$; $C_L = 50\text{ pF}$; see [Figure 13](#).

Symbol	Parameter	Conditions	Min	Typ	Max	Unit	
f_{\max}	maximum frequency	see Figure 7					
		$V_{CC} = 2.0\text{ V}$	3.0	10	-	MHz	
		$V_{CC} = 4.5\text{ V}$	15	29	-	MHz	
		$V_{CC} = 6.0\text{ V}$	18	35	-	MHz	
C_{PD}	power dissipation capacitance	$V_I = GND\text{ to }V_{CC}$	[3]	-	24	-	pF
$T_{\text{amb}} = -40\text{ °C to }+85\text{ °C}$							
t_{pd}	propagation delay	CP to \overline{TC} ; see Figure 7	[1]				
		$V_{CC} = 2.0\text{ V}$	-	-	375	ns	
		$V_{CC} = 4.5\text{ V}$	-	-	75	ns	
		$V_{CC} = 6.0\text{ V}$	-	-	64	ns	
		\overline{TE} to \overline{TC} ; see Figure 8					
		$V_{CC} = 2.0\text{ V}$	-	-	220	ns	
		$V_{CC} = 4.5\text{ V}$	-	-	44	ns	
		$V_{CC} = 6.0\text{ V}$	-	-	37	ns	
		\overline{PL} to \overline{TC} ; see Figure 9					
		$V_{CC} = 2.0\text{ V}$	-	-	395	ns	
		$V_{CC} = 4.5\text{ V}$	-	-	79	ns	
		$V_{CC} = 6.0\text{ V}$	-	-	40	ns	
t_{PHL}	HIGH to LOW propagation delay	\overline{MR} to \overline{TC} ; see Figure 9					
		$V_{CC} = 2.0\text{ V}$	-	-	345	ns	
		$V_{CC} = 4.5\text{ V}$	-	-	69	ns	
t_t	transition time	$V_{CC} = 6.0\text{ V}$	-	-	59	ns	
		see Figure 8	[2]				
		$V_{CC} = 2.0\text{ V}$	-	-	95	ns	
		$V_{CC} = 4.5\text{ V}$	-	-	19	ns	
		$V_{CC} = 6.0\text{ V}$	-	-	16	ns	
t_w	pulse width	CP HIGH or LOW; see Figure 7					
		$V_{CC} = 2.0\text{ V}$	205	-	-	ns	
		$V_{CC} = 4.5\text{ V}$	41	-	-	ns	
		$V_{CC} = 6.0\text{ V}$	35	-	-	ns	
		\overline{MR} LOW; see Figure 9					
		$V_{CC} = 2.0\text{ V}$	155	-	-	ns	
		$V_{CC} = 4.5\text{ V}$	31	-	-	ns	
		$V_{CC} = 6.0\text{ V}$	26	-	-	ns	
		\overline{PL} LOW; see Figure 9					
		$V_{CC} = 2.0\text{ V}$	155	-	-	ns	
		$V_{CC} = 4.5\text{ V}$	31	-	-	ns	
		$V_{CC} = 6.0\text{ V}$	26	-	-	ns	

Table 7. Dynamic characteristics ...continued
 $GND = 0\text{ V}$; $t_r = t_f = 6\text{ ns}$; $C_L = 50\text{ pF}$; see [Figure 13](#).

Symbol	Parameter	Conditions	Min	Typ	Max	Unit
t_{rec}	recovery time	$\overline{\text{MR}}$ to CP, $\overline{\text{PL}}$ to CP; see Figure 10				
		$V_{\text{CC}} = 2.0\text{ V}$	65	-	-	ns
		$V_{\text{CC}} = 4.5\text{ V}$	13	-	-	ns
		$V_{\text{CC}} = 6.0\text{ V}$	11	-	-	ns
t_{su}	set-up time	$\overline{\text{PE}}$ to CP; see Figure 11				
		$V_{\text{CC}} = 2.0\text{ V}$	95	-	-	ns
		$V_{\text{CC}} = 4.5\text{ V}$	19	-	-	ns
		$V_{\text{CC}} = 6.0\text{ V}$	16	-	-	ns
		$\overline{\text{TE}}$ to CP; see Figure 12				
		$V_{\text{CC}} = 2.0\text{ V}$	190	-	-	ns
		$V_{\text{CC}} = 4.5\text{ V}$	38	-	-	ns
		$V_{\text{CC}} = 6.0\text{ V}$	33	-	-	ns
		Pn to CP; see Figure 11				
		$V_{\text{CC}} = 2.0\text{ V}$	95	-	-	ns
		$V_{\text{CC}} = 4.5\text{ V}$	19	-	-	ns
		$V_{\text{CC}} = 6.0\text{ V}$	16	-	-	ns
t_{h}	hold time	$\overline{\text{PE}}$ to CP; see Figure 11				
		$V_{\text{CC}} = 2.0\text{ V}$	0	-	-	ns
		$V_{\text{CC}} = 4.5\text{ V}$	0	-	-	ns
		$V_{\text{CC}} = 6.0\text{ V}$	0	-	-	ns
		$\overline{\text{TE}}$ to CP; see Figure 12				
		$V_{\text{CC}} = 2.0\text{ V}$	0	-	-	ns
		$V_{\text{CC}} = 4.5\text{ V}$	0	-	-	ns
		$V_{\text{CC}} = 6.0\text{ V}$	0	-	-	ns
		Pn to CP; see Figure 11				
		$V_{\text{CC}} = 2.0\text{ V}$	0	-	-	ns
		$V_{\text{CC}} = 4.5\text{ V}$	0	-	-	ns
		$V_{\text{CC}} = 6.0\text{ V}$	0	-	-	ns
f_{max}	maximum frequency	see Figure 7				
		$V_{\text{CC}} = 2.0\text{ V}$	2.4	-	-	MHz
		$V_{\text{CC}} = 4.5\text{ V}$	12	-	-	MHz
		$V_{\text{CC}} = 6.0\text{ V}$	14	-	-	MHz

Table 7. Dynamic characteristics ...continued
 $GND = 0\text{ V}$; $t_r = t_f = 6\text{ ns}$; $C_L = 50\text{ pF}$; see [Figure 13](#).

Symbol	Parameter	Conditions	Min	Typ	Max	Unit		
$T_{\text{amb}} = -40\text{ °C to }+125\text{ °C}$								
t_{pd}	propagation delay	CP to $\overline{\text{TC}}$; see Figure 7 ^[1]						
		$V_{\text{CC}} = 2.0\text{ V}$	-	-	450	ns		
		$V_{\text{CC}} = 4.5\text{ V}$	-	-	90	ns		
		$V_{\text{CC}} = 6.0\text{ V}$	-	-	77	ns		
		$\overline{\text{TE}}$ to $\overline{\text{TC}}$; see Figure 8						
		$V_{\text{CC}} = 2.0\text{ V}$	-	-	265	ns		
		$V_{\text{CC}} = 4.5\text{ V}$	-	-	53	ns		
		$V_{\text{CC}} = 6.0\text{ V}$	-	-	45	ns		
		$\overline{\text{PL}}$ to $\overline{\text{TC}}$; see Figure 9						
		$V_{\text{CC}} = 2.0\text{ V}$	-	-	475	ns		
		$V_{\text{CC}} = 4.5\text{ V}$	-	-	95	ns		
		$V_{\text{CC}} = 6.0\text{ V}$	-	-	81	ns		
t_{PHL}	HIGH to LOW propagation delay	$\overline{\text{MR}}$ to $\overline{\text{TC}}$; see Figure 9						
		$V_{\text{CC}} = 2.0\text{ V}$	-	-	415	ns		
		$V_{\text{CC}} = 4.5\text{ V}$	-	-	83	ns		
		$V_{\text{CC}} = 6.0\text{ V}$	-	-	71	ns		
t_t	transition time	see Figure 8 ^[2]						
		$V_{\text{CC}} = 2.0\text{ V}$	-	-	110	ns		
		$V_{\text{CC}} = 4.5\text{ V}$	-	-	22	ns		
		$V_{\text{CC}} = 6.0\text{ V}$	-	-	19	ns		
t_w	pulse width	CP HIGH or LOW; see Figure 7						
		$V_{\text{CC}} = 2.0\text{ V}$	250	-	-	ns		
		$V_{\text{CC}} = 4.5\text{ V}$	50	-	-	ns		
		$V_{\text{CC}} = 6.0\text{ V}$	43	-	-	ns		
		$\overline{\text{MR}}$ LOW; see Figure 9						
		$V_{\text{CC}} = 2.0\text{ V}$	190	-	-	ns		
		$V_{\text{CC}} = 4.5\text{ V}$	38	-	-	ns		
		$V_{\text{CC}} = 6.0\text{ V}$	32	-	-	ns		
		$\overline{\text{PL}}$ LOW; see Figure 9						
		$V_{\text{CC}} = 2.0\text{ V}$	190	-	-	ns		
		$V_{\text{CC}} = 4.5\text{ V}$	38	-	-	ns		
		$V_{\text{CC}} = 6.0\text{ V}$	32	-	-	ns		
		t_{rec}	recovery time	$\overline{\text{MR}}$ to CP, $\overline{\text{PL}}$ to CP; see Figure 10				
				$V_{\text{CC}} = 2.0\text{ V}$	75	-	-	ns
$V_{\text{CC}} = 4.5\text{ V}$	15			-	-	ns		
$V_{\text{CC}} = 6.0\text{ V}$	13			-	-	ns		

Table 7. Dynamic characteristics ...continued
 $GND = 0\text{ V}$; $t_r = t_f = 6\text{ ns}$; $C_L = 50\text{ pF}$; see [Figure 13](#).

Symbol	Parameter	Conditions	Min	Typ	Max	Unit
t_{su}	set-up time	\overline{PE} to CP; see Figure 11				
		$V_{CC} = 2.0\text{ V}$	110	-	-	ns
		$V_{CC} = 4.5\text{ V}$	22	-	-	ns
		$V_{CC} = 6.0\text{ V}$	19	-	-	ns
		\overline{TE} to CP; see Figure 12				
		$V_{CC} = 2.0\text{ V}$	225	-	-	ns
		$V_{CC} = 4.5\text{ V}$	45	-	-	ns
		$V_{CC} = 6.0\text{ V}$	38	-	-	ns
		Pn to CP; see Figure 11				
		$V_{CC} = 2.0\text{ V}$	110	-	-	ns
		$V_{CC} = 4.5\text{ V}$	22	-	-	ns
		$V_{CC} = 6.0\text{ V}$	19	-	-	ns
t_h	hold time	\overline{PE} to CP; see Figure 11				
		$V_{CC} = 2.0\text{ V}$	0	-	-	ns
		$V_{CC} = 4.5\text{ V}$	0	-	-	ns
		$V_{CC} = 6.0\text{ V}$	0	-	-	ns
		\overline{TE} to CP; see Figure 12				
		$V_{CC} = 2.0\text{ V}$	0	-	-	ns
		$V_{CC} = 4.5\text{ V}$	0	-	-	ns
		$V_{CC} = 6.0\text{ V}$	0	-	-	ns
		Pn to CP; see Figure 11				
		$V_{CC} = 2.0\text{ V}$	0	-	-	ns
		$V_{CC} = 4.5\text{ V}$	0	-	-	ns
		$V_{CC} = 6.0\text{ V}$	0	-	-	ns
f_{max}	maximum frequency	see Figure 7				
		$V_{CC} = 2.0\text{ V}$	2.0	-	-	MHz
		$V_{CC} = 4.5\text{ V}$	10	-	-	MHz
		$V_{CC} = 6.0\text{ V}$	12	-	-	MHz

[1] t_{pd} is the same as t_{PHL} , t_{PLH} .

[2] t_t is the same as t_{THL} , t_{TLH} .

[3] C_{PD} is used to determine the dynamic power dissipation (P_D in μW).

$$P_D = C_{PD} \times V_{CC}^2 \times f_i \times N + \sum(C_L \times V_{CC}^2 \times f_o) \text{ where:}$$

f_i = input frequency in MHz;

f_o = output frequency in MHz;

C_L = output load capacitance in pF;

V_{CC} = supply voltage in V;

N = number of inputs switching;

$\sum(C_L \times V_{CC}^2 \times f_o)$ = sum of outputs.

12. Waveforms

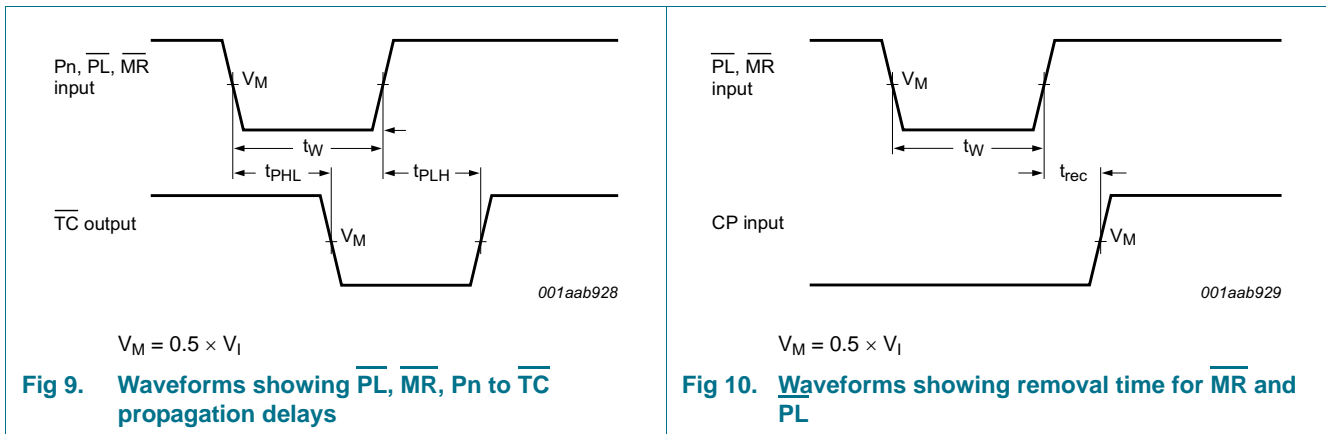
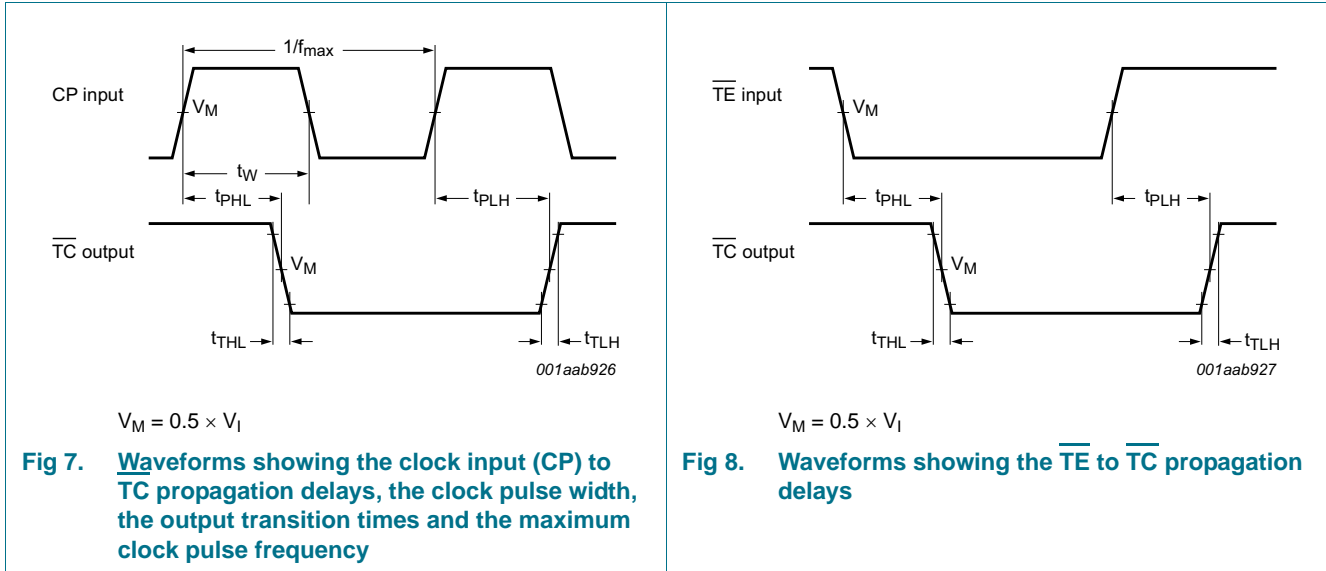

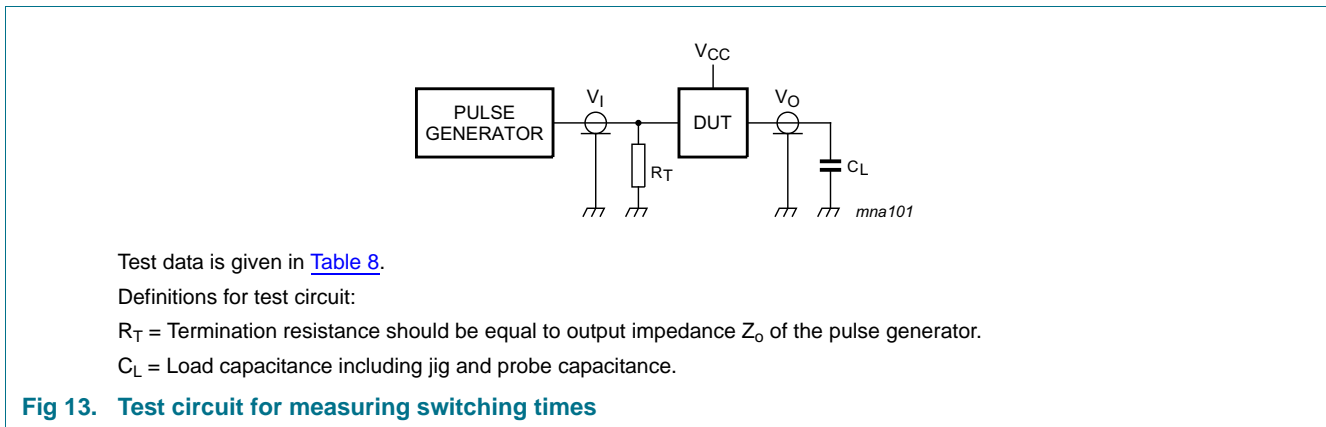
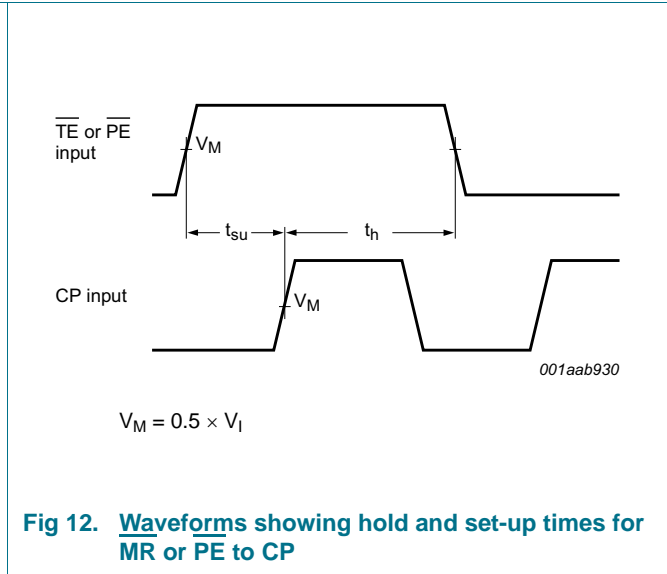
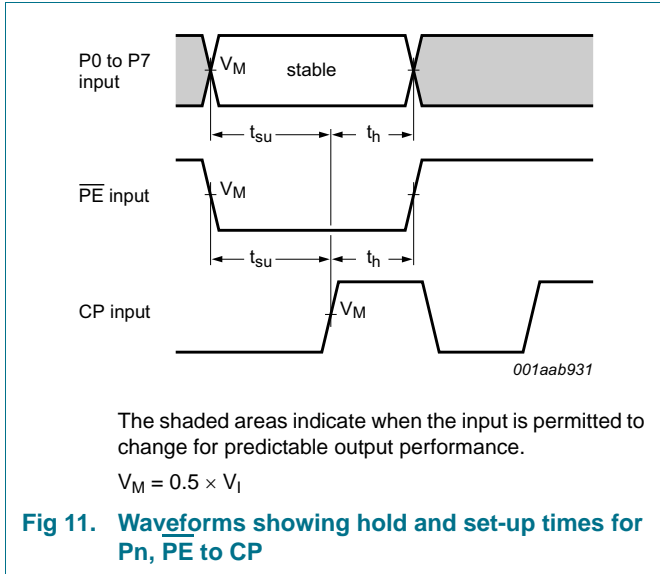

Table 8. Test data

Supply	Input	Load
V_{CC}	V_I	C_L
2.0 V	V_{CC}	50 pF
4.5 V	V_{CC}	50 pF
6.0 V	V_{CC}	50 pF
5.0 V	V_{CC}	15 pF

13. Application information

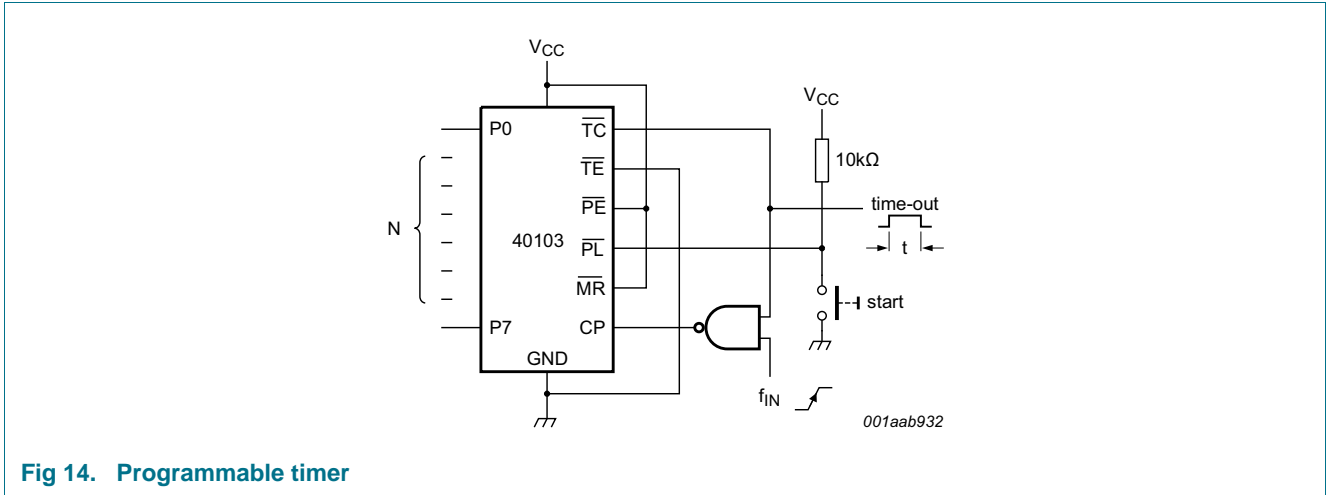

Fig 14. Programmable timer

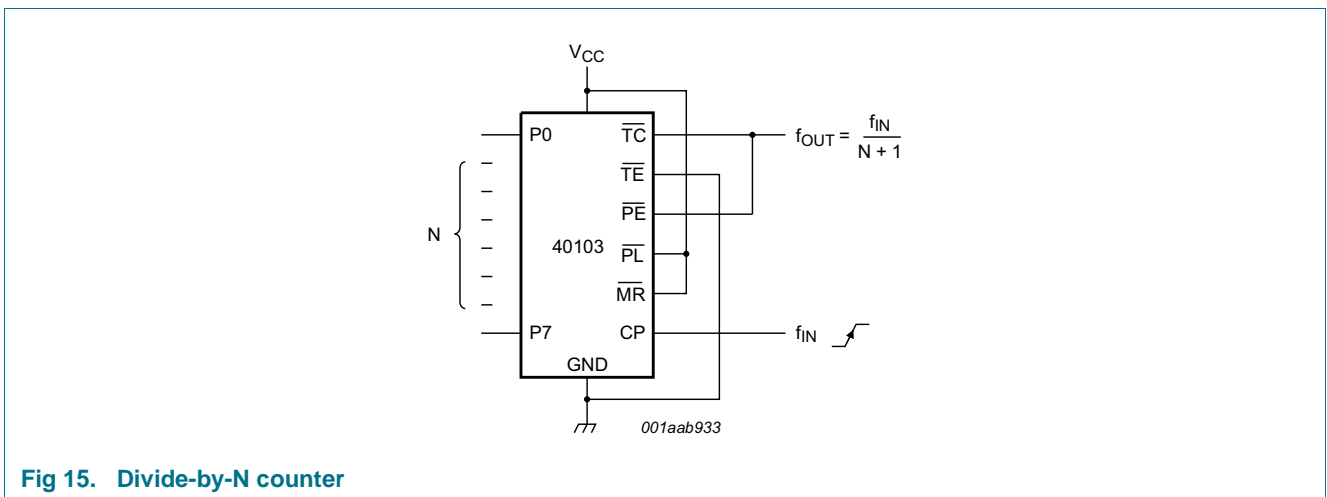

Fig 15. Divide-by-N counter

14. Package outline

SO16: plastic small outline package; 16 leads; body width 3.9 mm

SOT109-1

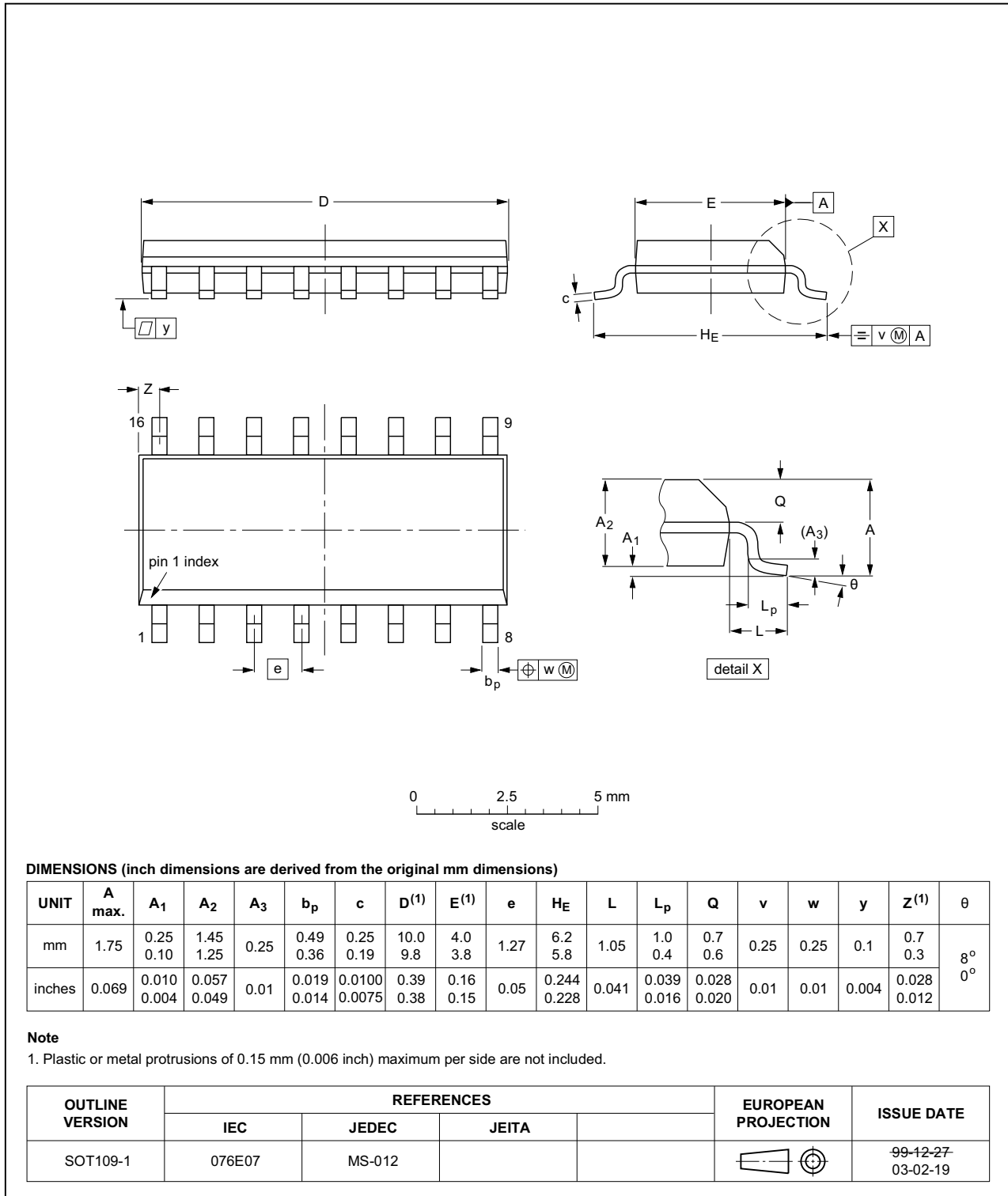

Fig 16. Package outline SOT109-1 (SO16)

TSSOP16: plastic thin shrink small outline package; 16 leads; body width 4.4 mm

SOT403-1

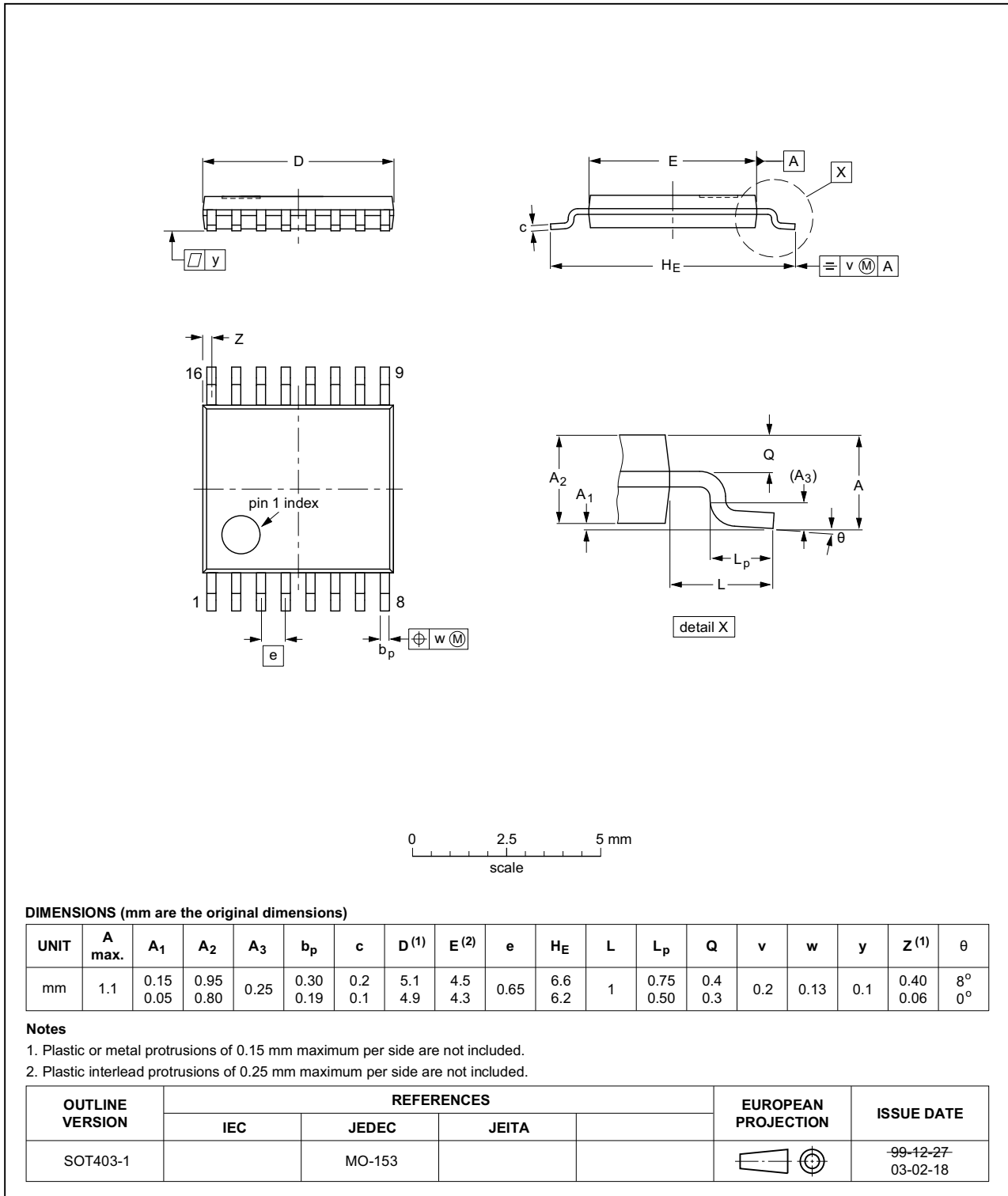

Fig 17. Package outline SOT403-1 (TSSOP16)

15. Abbreviations

Table 9. Abbreviations

Acronym	Description
CMOS	Complementary Metal Oxide Semiconductor
DUT	Device Under Test
ESD	ElectroStatic Discharge
HBM	Human Body Model
MM	Machine Model

16. Revision history

Table 10. Revision history

Document ID	Release date	Data sheet status	Change notice	Supersedes
74HC40103 v.5	20160421	Product data sheet	-	74HC40103 v.4
Modifications:	<ul style="list-style-type: none"> Type number 74HC40103DB (SOT338-1) removed. 			
74HC40103 v.4	20160127	Product data sheet	-	74HC40103 v.3
Modifications:	<ul style="list-style-type: none"> Type number 74HC40103N (SOT38-4) removed. 			
74HC40103 v.3	20041112	Product data sheet	-	74HC_HCT40103_CNV v.2
Modifications:	<ul style="list-style-type: none"> The format of this data sheet has been redesigned to comply with the current presentation and information standard of Philips Semiconductors. Removed type number 74HCT40103. Inserted family specification. 			
74HC_HCT40103_CNV v.2	19970918	Product specification	-	74HC_HCT40103 v.1
74HC_HCT40103 v.1	19901201	Product specification	-	-

17. Legal information

17.1 Data sheet status

Document status ^{[1][2]}	Product status ^[3]	Definition
Objective [short] data sheet	Development	This document contains data from the objective specification for product development.
Preliminary [short] data sheet	Qualification	This document contains data from the preliminary specification.
Product [short] data sheet	Production	This document contains the product specification.

[1] Please consult the most recently issued document before initiating or completing a design.

[2] The term 'short data sheet' is explained in section "Definitions".

[3] The product status of device(s) described in this document may have changed since this document was published and may differ in case of multiple devices. The latest product status information is available on the Internet at URL <http://www.nexperia.com>.

17.2 Definitions

Draft — The document is a draft version only. The content is still under internal review and subject to formal approval, which may result in modifications or additions. Nexperia does not give any representations or warranties as to the accuracy or completeness of information included herein and shall have no liability for the consequences of use of such information.

Short data sheet — A short data sheet is an extract from a full data sheet with the same product type number(s) and title. A short data sheet is intended for quick reference only and should not be relied upon to contain detailed and full information. For detailed and full information see the relevant full data sheet, which is available on request via the local Nexperia sales office. In case of any inconsistency or conflict with the short data sheet, the full data sheet shall prevail.

Product specification — The information and data provided in a Product data sheet shall define the specification of the product as agreed between Nexperia and its customer, unless Nexperia and customer have explicitly agreed otherwise in writing. In no event however, shall an agreement be valid in which the Nexperia product is deemed to offer functions and qualities beyond those described in the Product data sheet.

17.3 Disclaimers

Limited warranty and liability — Information in this document is believed to be accurate and reliable. However, Nexperia does not give any representations or warranties, expressed or implied, as to the accuracy or completeness of such information and shall have no liability for the consequences of use of such information. Nexperia takes no responsibility for the content in this document if provided by an information source outside of Nexperia.

In no event shall Nexperia be liable for any indirect, incidental, punitive, special or consequential damages (including - without limitation - lost profits, lost savings, business interruption, costs related to the removal or replacement of any products or rework charges) whether or not such damages are based on tort (including negligence), warranty, breach of contract or any other legal theory.

Notwithstanding any damages that customer might incur for any reason whatsoever, Nexperia's aggregate and cumulative liability towards customer for the products described herein shall be limited in accordance with the *Terms and conditions of commercial sale* of Nexperia.

Right to make changes — Nexperia reserves the right to make changes to information published in this document, including without limitation specifications and product descriptions, at any time and without notice. This document supersedes and replaces all information supplied prior to the publication hereof.

Suitability for use — Nexperia products are not designed, authorized or warranted to be suitable for use in life support, life-critical or safety-critical systems or equipment, nor in applications where failure or malfunction of a Nexperia product can reasonably be expected to result in personal injury, death or severe property or environmental damage. Nexperia and its suppliers accept no liability for inclusion and/or use of Nexperia products in such equipment or applications and therefore such inclusion and/or use is at the customer's own risk.

Applications — Applications that are described herein for any of these products are for illustrative purposes only. Nexperia makes no representation or warranty that such applications will be suitable for the specified use without further testing or modification.

Customers are responsible for the design and operation of their applications and products using Nexperia products, and Nexperia accepts no liability for any assistance with applications or customer product design. It is customer's sole responsibility to determine whether the Nexperia product is suitable and fit for the customer's applications and products planned, as well as for the planned application and use of customer's third party customer(s). Customers should provide appropriate design and operating safeguards to minimize the risks associated with their applications and products.

Nexperia does not accept any liability related to any default, damage, costs or problem which is based on any weakness or default in the customer's applications or products, or the application or use by customer's third party customer(s). Customer is responsible for doing all necessary testing for the customer's applications and products using Nexperia products in order to avoid a default of the applications and the products or of the application or use by customer's third party customer(s). Nexperia does not accept any liability in this respect.

Limiting values — Stress above one or more limiting values (as defined in the Absolute Maximum Ratings System of IEC 60134) will cause permanent damage to the device. Limiting values are stress ratings only and (proper) operation of the device at these or any other conditions above those given in the Recommended operating conditions section (if present) or the Characteristics sections of this document is not warranted. Constant or repeated exposure to limiting values will permanently and irreversibly affect the quality and reliability of the device.

Terms and conditions of commercial sale — Nexperia products are sold subject to the general terms and conditions of commercial sale, as published at <http://www.nexperia.com/profile/terms>, unless otherwise agreed in a valid written individual agreement. In case an individual agreement is concluded only the terms and conditions of the respective agreement shall apply. Nexperia hereby expressly objects to applying the customer's general terms and conditions with regard to the purchase of Nexperia products by customer.

No offer to sell or license — Nothing in this document may be interpreted or construed as an offer to sell products that is open for acceptance or the grant, conveyance or implication of any license under any copyrights, patents or other industrial or intellectual property rights.

Export control — This document as well as the item(s) described herein may be subject to export control regulations. Export might require a prior authorization from competent authorities.

Non-automotive qualified products — Unless this data sheet expressly states that this specific Nexperia product is automotive qualified, the product is not suitable for automotive use. It is neither qualified nor tested in accordance with automotive testing or application requirements. Nexperia accepts no liability for inclusion and/or use of non-automotive qualified products in automotive equipment or applications.

In the event that customer uses the product for design-in and use in automotive applications to automotive specifications and standards, customer (a) shall use the product without Nexperia's warranty of the product for such automotive applications, use and specifications, and (b) whenever customer uses the product for automotive applications beyond

Nexperia's specifications such use shall be solely at customer's own risk, and (c) customer fully indemnifies Nexperia for any liability, damages or failed product claims resulting from customer design and use of the product for automotive applications beyond Nexperia's standard warranty and Nexperia's product specifications.

Translations — A non-English (translated) version of a document is for reference only. The English version shall prevail in case of any discrepancy between the translated and English versions.

17.4 Trademarks

Notice: All referenced brands, product names, service names and trademarks are the property of their respective owners.

18. Contact information

For more information, please visit: <http://www.nexperia.com>



For sales office addresses, please send an email to: salesaddresses@nexperia.com

19. Contents

1	General description	1
2	Features and benefits	1
3	Applications	1
4	Ordering information	2
5	Functional diagram	2
6	Pinning information	5
6.1	Pinning	5
6.2	Pin description	5
7	Functional description	6
7.1	Function table	6
8	Limiting values	6
9	Recommended operating conditions	7
10	Static characteristics	7
11	Dynamic characteristics	9
12	Waveforms	15
13	Application information	17
14	Package outline	18
15	Abbreviations	20
16	Revision history	20
17	Legal information	21
17.1	Data sheet status	21
17.2	Definitions	21
17.3	Disclaimers	21
17.4	Trademarks	22
18	Contact information	22
19	Contents	23

Looking for pricing, stock, or lifecycle information?

Click below to explore more details on WIN SOURCE:

-  [View 74HC40103D,653 on WIN SOURCE](#)
-  [NXP / Nexperia Information](#)

Optimize Your Supply Chain with WIN SOURCE Solutions

-  Global Sourcing Solution
-  Obsolete Management
-  Cost Control Management
-  Shortage Management
-  Alternative Solution
-  Excess Inventory Management