



**THE DATASHEET OF  
SN74HC74DR**



## SNx4HC74 Dual D-Type Positive-Edge-Triggered Flip-Flops With Clear and Preset

### 1 Features

- Wide Operating Voltage Range: 2 V to 6 V
- Outputs Can Drive Up To 10 LSTTL Loads
- Low Power Consumption, 40- $\mu$ A Maximum  $I_{CC}$
- Typical  $t_{pd} = 15$  ns
- $\pm 4$ -mA Output Drive at 5 V
- Very Low Input Current of 1  $\mu$ A

### 2 Applications

- Ultrasound System
- Fans
- Lab Instrumentation
- Vacuum Cleaners
- Video Communications System
- IP Phone: Wired

### 3 Description

The SNx4HC74 devices contain two independent D-type positive-edge-triggered flip-flops. A low level at the preset ( $\overline{PRE}$ ) or clear ( $\overline{CLR}$ ) inputs sets or resets the outputs, regardless of the levels of the other inputs. When  $\overline{PRE}$  and  $\overline{CLR}$  are inactive (high), data at the data (D) input meeting the setup time requirements are transferred to the outputs on the positive-going edge of the clock (CLK) pulse. Clock triggering occurs at a voltage level and is not directly related to the rise time of CLK. Following the hold-time interval, data at the D input can be changed without affecting the levels at the outputs.

#### Device Information<sup>(1)</sup>

PART NUMBER	PACKAGE	BODY SIZE (NOM)
SN74HC74N	PDIP (14)	19.30 mm x 6.40 mm
SN74HC74NS	SO (14)	10.20 mm x 5.30 mm
SN74HC74D	SOIC (14)	8.70 mm x 3.90 mm
SN74HC74DB	SSOP (14)	6.50 mm x 5.30 mm
SN74HC74PW	TSSOP (14)	5.00 mm x 4.40 mm
SNJ54HC74J	CDIP (14)	21.30 mm x 7.60 mm
SNJ54HC74W	CFP (14)	9.20 mm x 6.29 mm
SNJ54HC74FK	LCCC (20)	8.90 mm x 8.90 mm

(1) For all available packages, see the orderable addendum at the end of the data sheet.

#### Logic Diagram (Positive Logic)

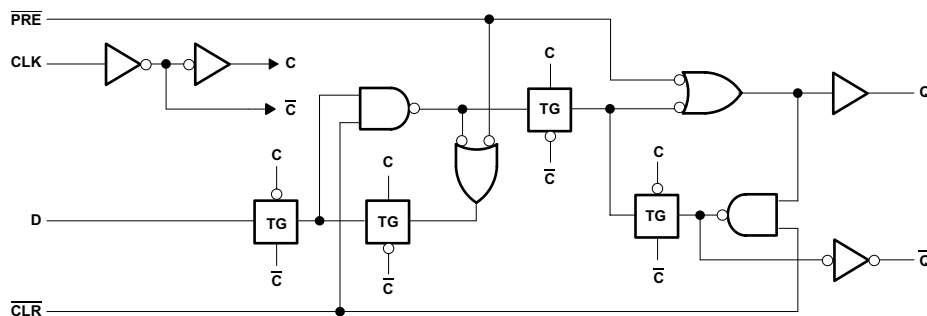

## Table of Contents

<b>1 Features</b> .....	<b>1</b>	8.3 Feature Description .....	<b>10</b>
<b>2 Applications</b> .....	<b>1</b>	8.4 Device Functional Modes .....	<b>10</b>
<b>3 Description</b> .....	<b>1</b>	<b>9 Application and Implementation</b> .....	<b>11</b>
<b>4 Revision History</b> .....	<b>2</b>	9.1 Application Information .....	<b>11</b>
<b>5 Pin Configuration and Functions</b> .....	<b>3</b>	9.2 Typical Application .....	<b>11</b>
<b>6 Specifications</b> .....	<b>4</b>	<b>10 Power Supply Recommendations</b> .....	<b>12</b>
6.1 Absolute Maximum Ratings .....	<b>4</b>	<b>11 Layout</b> .....	<b>13</b>
6.2 ESD Ratings .....	<b>4</b>	11.1 Layout Guidelines .....	<b>13</b>
6.3 Recommended Operating Conditions .....	<b>4</b>	11.2 Layout Example .....	<b>13</b>
6.4 Thermal Information .....	<b>5</b>	<b>12 Device and Documentation Support</b> .....	<b>14</b>
6.5 Electrical Characteristics .....	<b>5</b>	12.1 Documentation Support .....	<b>14</b>
6.6 Timing Requirements .....	<b>6</b>	12.2 Related Links .....	<b>14</b>
6.7 Switching Characteristics .....	<b>7</b>	12.3 Community Resources .....	<b>14</b>
6.8 Typical Characteristics .....	<b>8</b>	12.4 Trademarks .....	<b>14</b>
<b>7 Parameter Measurement Information</b> .....	<b>9</b>	12.5 Electrostatic Discharge Caution .....	<b>14</b>
<b>8 Detailed Description</b> .....	<b>10</b>	12.6 Glossary .....	<b>14</b>
8.1 Overview .....	<b>10</b>	<b>13 Mechanical, Packaging, and Orderable Information</b> .....	<b>14</b>
8.2 Functional Block Diagram .....	<b>10</b>		

## 4 Revision History

### Changes from Revision D (July 2003) to Revision E

**Page**

- Added *Applications*, *Device Information* table, *Pin Functions* table, *ESD Ratings* table, *Thermal Information* table, *Typical Characteristics*, *Feature Description* section, *Device Functional Modes*, *Application and Implementation* section, *Power Supply Recommendations* section, *Layout* section, *Device and Documentation Support* section, and *Mechanical, Packaging, and Orderable Information* section. .... **1**

## 5 Pin Configuration and Functions

N, NS, D, DB, PW, J, or W Package  
14-Pin PDIP, SO, SOIC, SSOP, TSSOP, CDIP, or CFP  
Top View

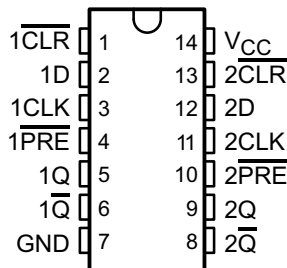

FK Package  
20-Pin LCCC  
Top View

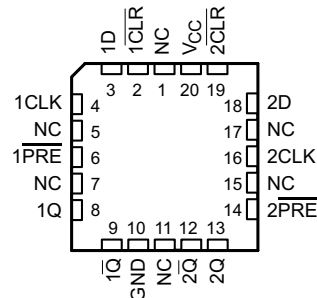

NC – No internal connection

### Pin Functions

NAME	PIN		I/O	DESCRIPTION
	LCCC	SOIC, SSOP, CDIP, PDIP, SO, TSSOP, CFP NO.		
1CLK	4	3	I	Clock input
1CLR	2	1	I	Clear input - Pull low to set 1Q output low
1D	3	2	I	Input
1PRE	6	4	I	Preset input
1Q	8	5	O	Output
1Q	9	6	O	Inverted output
2CLK	16	11	I	Clock input
2CLR	19	13	I	Clear input - Pull low to set 1Q output low
2D	18	12	I	Input
2PRE	14	10	I	Preset input
2Q	13	9	O	Output
2Q	12	8	O	Inverted output
GND	10	7	—	Ground
NC	1	—	—	No connect (no internal connection)
	5			
	7			
	11			
	15			
V <sub>CC</sub>	20	14	—	Supply

## 6 Specifications

### 6.1 Absolute Maximum Ratings

 over operating free-air temperature range (unless otherwise noted) <sup>(1)</sup>

		MIN	MAX	UNIT
$V_{CC}$	Supply voltage range	-0.5	7	V
$I_{IK}$	Input clamp current <sup>(2)</sup>	$V_I < 0$ or $V_I > V_{CC}$		±20 mA
$I_{OK}$	Output clamp current <sup>(2)</sup>	$V_O < 0$ or $V_O > V_{CC}$		±20 mA
$I_O$	Continuous output current	$V_O = 0$ to $V_{CC}$		±25 mA
Continuous current through $V_{CC}$ or GND				±50 mA
$T_j$	Junction temperature range			150 °C
$T_{stg}$	Storage temperature range	-65	150	°C

- (1) Stresses beyond those listed under “absolute maximum ratings” may cause permanent damage to the device. These are stress ratings only, and functional operation of the device at these or any other conditions beyond those indicated under “recommended operating conditions” is not implied. Exposure to absolute-maximum-rated conditions for extended periods may affect device reliability.
- (2) The input and output voltage ratings may be exceeded if the input and output current ratings are observed.

### 6.2 ESD Ratings

		VALUE	UNIT
$V_{(ESD)}$	Electrostatic discharge		V
	Human-body model (HBM), per ANSI/ESDA/JEDEC JS-001 <sup>(1)</sup>	±2000	
	Charged-device model (CDM), per JEDEC specification JESD22-C101 <sup>(2)</sup>	±1500	

- (1) JEDEC document JEP155 states that 500-V HBM allows safe manufacturing with a standard ESD control process. Manufacturing with less than 500-V HBM is possible with the necessary precautions.
- (2) JEDEC document JEP157 states that 250-V CDM allows safe manufacturing with a standard ESD control process. Manufacturing with less than 250-V CDM is possible with the necessary precautions.

### 6.3 Recommended Operating Conditions

 See <sup>(1)</sup>

		SN54HC74			SN74HC74			UNIT
		MIN	NOM	MAX	MIN	NOM	MAX	
$V_{CC}$	Supply voltage	2	5	6	2	5	6	V
$V_{IH}$	High-level input voltage	$V_{CC} = 2$ V		1.5	1.5		V	
		$V_{CC} = 4.5$ V		3.15	3.15			
		$V_{CC} = 6$ V		4.2	4.2			
$V_{IL}$	Low-level input voltage	$V_{CC} = 2$ V			0.5		V	
		$V_{CC} = 4.5$ V			1.35			
		$V_{CC} = 6$ V			1.8			
$V_I$	Input voltage	0		$V_{CC}$	0		$V_{CC}$	V
$V_O$	Output voltage	0		$V_{CC}$	0		$V_{CC}$	V
$\Delta t/\Delta v$	Input transition rise and fall time	$V_{CC} = 2$ V			1000		ns	
		$V_{CC} = 4.5$ V			500			
		$V_{CC} = 6$ V			400			
$T_A$	Operating free-air temperature	-55		125	-40		85	°C

- (1) All unused inputs of the device must be held at  $V_{CC}$  or GND to ensure proper device operation. Refer to the TI application report, *Implications of Slow or Floating CMOS Inputs*, [SCBA004](#).

## 6.4 Thermal Information

THERMAL METRIC <sup>(1)</sup>	SN74HC74					SN54HC74			UNIT		
	D (SOIC)	DB (SSOP)	N (PDIP)	NS (SO)	PW (TSSOP)	J (CDIP)	W (CFP)	FK (LCCC)			
	14 PINS					14 PINS		20 PINS			
R <sub>θJA</sub>	Junction-to-ambient thermal resistance		86	96	80	76	113	—	—	—	°C/W
R <sub>θJC(top)</sub>	Junction-to-case (top) thermal resistance		—	—	—	—	—	15.05	14.65	5.61	

(1) For more information about traditional and new thermal metrics, see the *Semiconductor and IC Package Thermal Metrics* application report, [SPRA953](#).

## 6.5 Electrical Characteristics

over recommended operating free-air temperature range, T<sub>A</sub> = 25°C (unless otherwise noted)

PARAMETER	TEST CONDITIONS		V <sub>CC</sub>	MIN	TYP	MAX	UNIT	
V <sub>OH</sub>	V <sub>I</sub> = V <sub>IH</sub> or V <sub>IL</sub>	I <sub>OH</sub> = -20 μA	2 V	1.9	1.998		V	
			4.5 V	4.4	4.499			
			6 V	5.9	5.999			
		I <sub>OH</sub> = -4 mA	T <sub>A</sub> = 25°C	4.5 V	3.98	4.3		
			SN54HC74		3.7			
			SN74HC74		3.84			
	I <sub>OH</sub> = -5.2 mA	T <sub>A</sub> = 25°C	6 V	5.48	5.8			
		SN54HC74		5.2				
SN74HC74	5.34							
V <sub>OL</sub>	V <sub>I</sub> = V <sub>IH</sub> or V <sub>IL</sub>	I <sub>OL</sub> = 20 μA	2 V		0.002	0.1	V	
			4.5 V		0.001	0.1		
			6 V		0.001	0.1		
		I <sub>OL</sub> = 4 mA	T <sub>A</sub> = 25°C	4.5 V		0.17		0.26
			SN54HC74					0.4
			SN74HC74					0.33
		I <sub>OL</sub> = 5.2 mA	T <sub>A</sub> = 25°C	6 V		0.15		0.26
			SN54HC74					0.4
SN74HC74			0.33					
I <sub>I</sub>	V <sub>I</sub> = V <sub>CC</sub> or 0	T <sub>A</sub> = 25°C	6 V		±0.1	±100	nA	
		SN54HC74, SN74HC74				±1000		
I <sub>CC</sub>	V <sub>I</sub> = V <sub>CC</sub> or 0,	I <sub>O</sub> = 0	T <sub>A</sub> = 25°C	6 V		4	μA	
			SN54HC74			80		
			SN74HC74			40		
C <sub>i</sub>			2 V to 6 V		3	10	pF	
C <sub>pd</sub>	No load		2 V to 6 V		35		pF	

## 6.6 Timing Requirements

 over recommended operating free-air temperature range,  $T_A = 25^\circ\text{C}$  (unless otherwise noted)

		$V_{CC}$	$T_A$	MIN	MAX	UNIT
$f_{\text{clock}}$	Clock frequency	2 V	$T_A = 25^\circ\text{C}$		6	MHz
			SN54HC74		4.2	
			SN74HC74		5	
		4.5 V	$T_A = 25^\circ\text{C}$		31	
			SN54HC74		21	
			SN74HC74		25	
		6 V	$T_A = 25^\circ\text{C}$	0	36	
			SN54HC74	0	25	
			SN74HC74	0	29	
$t_w$	$\overline{\text{PRE}}$ or $\overline{\text{CLR}}$ low	2 V	$T_A = 25^\circ\text{C}$	100		ns
			SN54HC74	150		
			SN74HC74	125		
		4.5 V	$T_A = 25^\circ\text{C}$	20		
			SN54HC74	30		
			SN74HC74	25		
		6 V	$T_A = 25^\circ\text{C}$	14		
			SN54HC74	25		
			SN74HC74	21		
	CLK high or low	2 V	$T_A = 25^\circ\text{C}$	80		
			SN54HC74	120		
			SN74HC74	100		
		4.5 V	$T_A = 25^\circ\text{C}$	16		
			SN54HC74	24		
			SN74HC74	20		
		6 V	$T_A = 25^\circ\text{C}$	14		
			SN54HC74	20		
			SN74HC74	17		
$t_{\text{su}}$	Data	2 V	$T_A = 25^\circ\text{C}$	100		ns
			SN54HC74	150		
			SN74HC74	125		
		4.5 V	$T_A = 25^\circ\text{C}$	20		
			SN54HC74	30		
			SN74HC74	25		
		6 V	$T_A = 25^\circ\text{C}$	17		
			SN54HC74	25		
			SN74HC74	21		
	$\overline{\text{PRE}}$ or $\overline{\text{CLR}}$ inactive	2 V	$T_A = 25^\circ\text{C}$	25		
			SN54HC74	40		
			SN74HC74	30		
		4.5 V	$T_A = 25^\circ\text{C}$	5		
			SN54HC74	8		
			SN74HC74	6		
		6 V	$T_A = 25^\circ\text{C}$	4		
			SN54HC74	7		
			SN74HC74	5		

## Timing Requirements (continued)

 over recommended operating free-air temperature range,  $T_A = 25^\circ\text{C}$  (unless otherwise noted)

		$V_{CC}$	$T_A$	MIN	MAX	UNIT
$t_h$	Hold time, data after CLK↑	2 V		0		ns
		4.5 V		0		
		6 V		0		

## 6.7 Switching Characteristics

 over recommended operating free-air temperature range,  $C_L = 50$  pF (unless otherwise noted) (see [Figure 2](#))

PARAMETER	FROM (INPUT)	TO (OUTPUT)	$V_{CC}$	$T_A$	MIN	TYP	MAX	UNIT	
$f_{max}$			2 V	$T_A = 25^\circ\text{C}$	6	10		MHz	
				SN54HC74	4.2				
				SN74HC74	6				
			4.5 V	$T_A = 25^\circ\text{C}$	31	50			
				SN54HC74	21				
				SN74HC74	25				
			6 V	$T_A = 25^\circ\text{C}$	36	60			
				SN54HC74	25				
				SN74HC74	29				
$t_{pd}$	$\overline{PRE}$ or $\overline{CLR}$	Q or $\overline{Q}$	2 V	$T_A = 25^\circ\text{C}$		70	230	ns	
				SN54HC74			345		
				SN74HC74			290		
			4.5 V	$T_A = 25^\circ\text{C}$		20	46		
				SN54HC74			69		
				SN74HC74			58		
			6 V	$T_A = 25^\circ\text{C}$		15	39		
				SN54HC74			59		
				SN74HC74			49		
	CLK	Q or $\overline{Q}$	2 V	$T_A = 25^\circ\text{C}$		70	175		
				SN54HC74			250		
				SN74HC74			220		
			4.5 V	$T_A = 25^\circ\text{C}$		20	35		
				SN54HC74			50		
				SN74HC74			44		
			6 V	$T_A = 25^\circ\text{C}$		15	30		
				SN54HC74			42		
				SN74HC74			37		
$t_t$		Q or $\overline{Q}$	2 V	$T_A = 25^\circ\text{C}$		28	75	ns	
				SN54HC74			110		
				SN74HC74			95		
			4.5 V	$T_A = 25^\circ\text{C}$		8	15		
				SN54HC74			22		
				SN74HC74			19		
			6 V	$T_A = 25^\circ\text{C}$		6	13		
				SN54HC74			19		
				SN74HC74			16		

## 6.8 Typical Characteristics

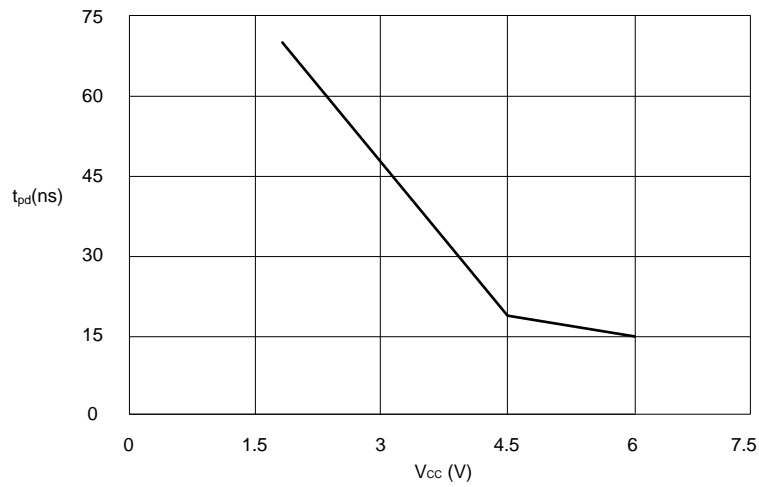

**Figure 1. Typical Propagation Delay - CLK to Q**

## 7 Parameter Measurement Information

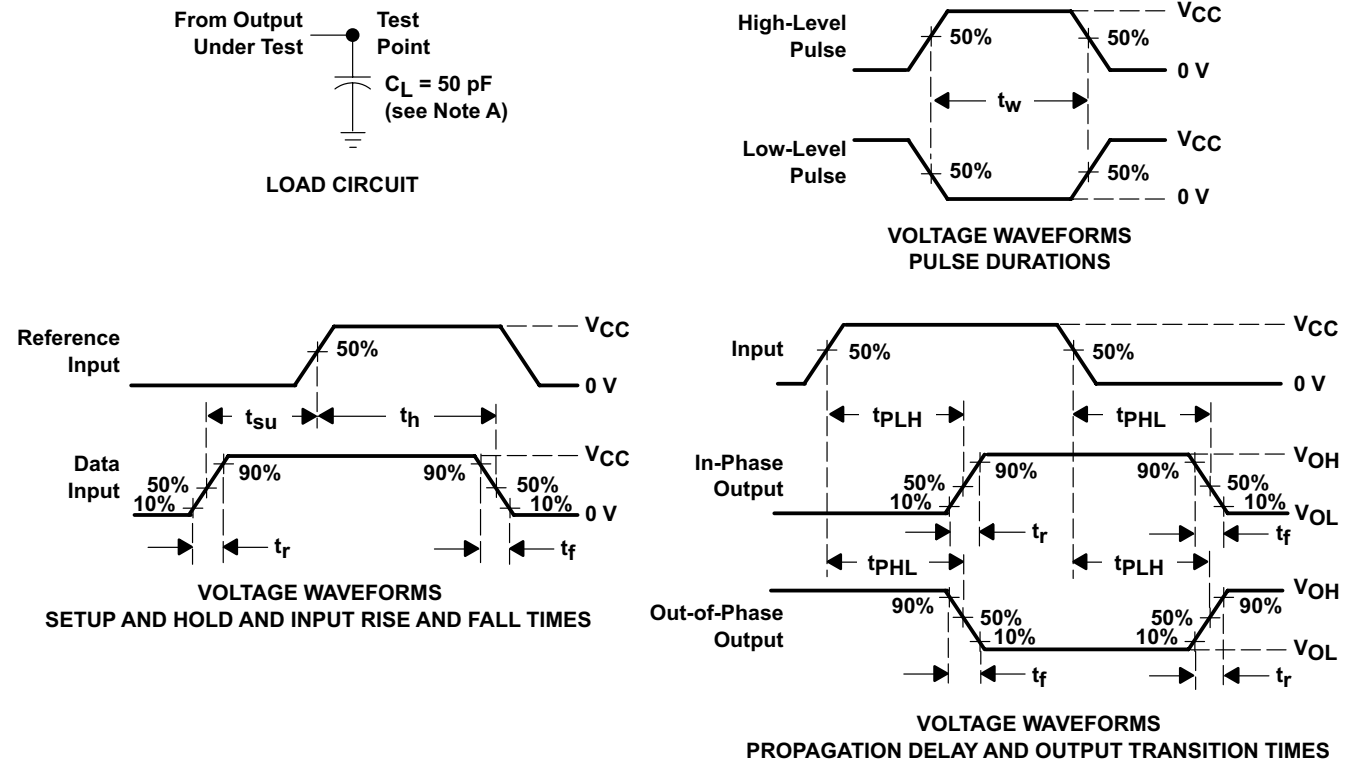

- A.  $C_L$  includes probe and test-fixture capacitance.
- B. Phase relationships between waveforms were chosen arbitrarily. All input pulses are supplied by generators having the following characteristics:  $PRR \leq 1 \text{ MHz}$ ,  $Z_O = 50 \Omega$ ,  $t_r = 6 \text{ ns}$ ,  $t_f = 6 \text{ ns}$ .
- C. For clock inputs,  $f_{max}$  is measured when the input duty cycle is 50%.
- D. The outputs are measured one at a time with one input transition per measurement.
- E.  $t_{PLH}$  and  $t_{PHL}$  are the same as  $t_{pd}$ .

**Figure 2. Load Circuit and Voltage Waveforms**

## 8 Detailed Description

### 8.1 Overview

Figure 3 describes the SNx4HC74 devices. As the SNx4HC74 is a dual D-Type positive-edge-triggered flip-flop with clear and preset, the diagram below describes one of the two device flip-flops.

### 8.2 Functional Block Diagram

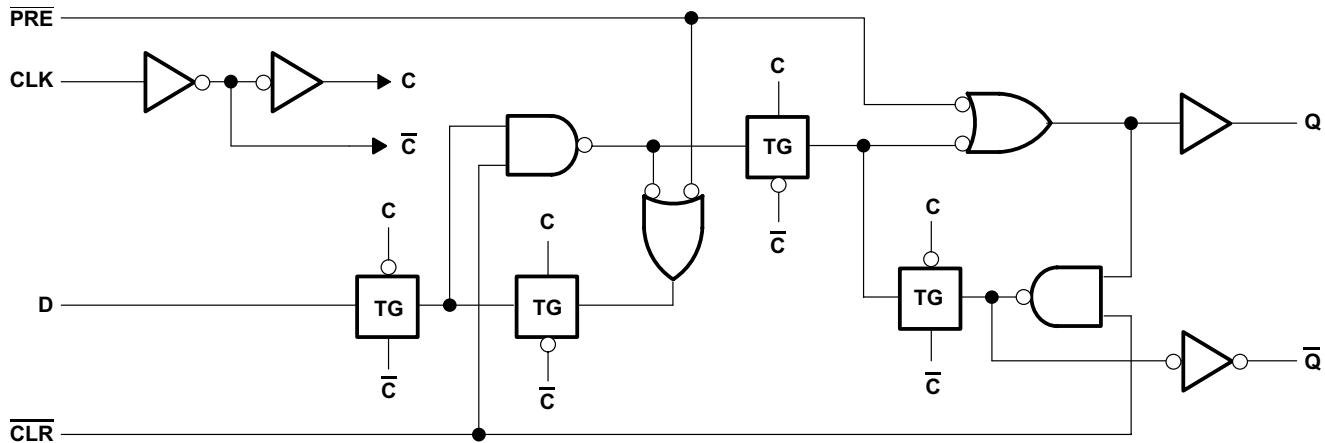

Figure 3. Logic Diagram (Positive Logic)

### 8.3 Feature Description

The SNx4HC74 inputs accept voltage levels up to 5.5 V. Refer to the [Recommended Operating Conditions](#) for appropriate input high and low logic levels.

### 8.4 Device Functional Modes

Table 1 lists the functional modes of the SNx4HC74.

Table 1. Function Table

INPUTS				OUTPUTS	
$\overline{\text{PRE}}$	$\overline{\text{CLR}}$	CLK	D	Q	$\overline{\text{Q}}$
L	H	X	X	H	L
H	L	X	X	L	H
L	L	X	X	H <sup>(1)</sup>	H <sup>(1)</sup>
H	H	↑	H	H	L
H	H	↑	L	L	H
H	H	L	X	Q <sub>0</sub>	$\overline{\text{Q}}_0$

(1) This configuration is nonstable; that is, it does not persist when  $\overline{\text{PRE}}$  or  $\overline{\text{CLR}}$  returns to its inactive (high) level.

## 9 Application and Implementation

### NOTE

Information in the following applications sections is not part of the TI component specification, and TI does not warrant its accuracy or completeness. TI's customers are responsible for determining suitability of components for their purposes. Customers should validate and test their design implementation to confirm system functionality.

### 9.1 Application Information

A low level at the preset ( $\overline{\text{PRE}}$ ) or clear ( $\overline{\text{CLR}}$ ) input sets or resets the outputs, regardless of the levels of the other inputs. When  $\overline{\text{PRE}}$  and  $\overline{\text{CLR}}$  are inactive (high), data at the data (D) input meeting the setup time requirements is transferred to the outputs on the positive-going edge of the clock pulse. Clock triggering occurs at a voltage level and is not related directly to the rise time of the clock pulse. Following the hold-time interval, data at the D input can be changed without affecting the levels at the outputs.

The resistor and capacitor at the  $\overline{\text{CLR}}$  pin are optional. If they are not used, the  $\overline{\text{CLR}}$  pin should be connected directly to  $V_{\text{CC}}$  to be inactive.

### 9.2 Typical Application

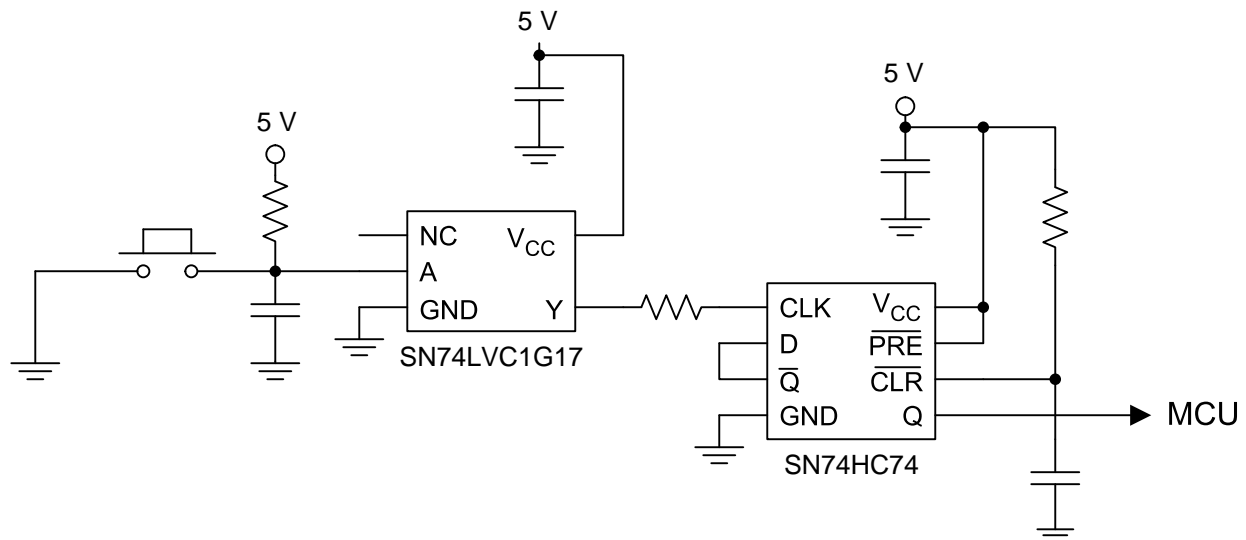

Figure 4. Device Power Button Circuit

#### 9.2.1 Design Requirements

This device uses CMOS technology and has balanced output drive. Take care to avoid bus contention because it can drive currents that would exceed maximum limits. Outputs may be combined to produce higher drive, but the high drive will also create faster edges into light loads. Because of this, routing and load conditions should be considered to prevent ringing.

#### 9.2.2 Detailed Design Procedure

##### 1. Recommended Input Conditions:

- For rise time and fall time specifications, see ( $\Delta t/\Delta V$ ) in [Recommended Operating Conditions](#) table.
- For specified high and low levels, see ( $V_{\text{IH}}$  and  $V_{\text{IL}}$ ) in [Recommended Operating Conditions](#) table.
- Inputs are overvoltage tolerant allowing them to go as high as 5.5 V at any valid  $V_{\text{CC}}$ .

##### 2. Recommended Output Conditions:

- Load currents should not exceed 25 mA per output and 50 mA total for the part.
- Series resistors on the output may be used if the user desires to slow the output edge signal or limit the output current.

## Typical Application (continued)

### 9.2.3 Application Curve

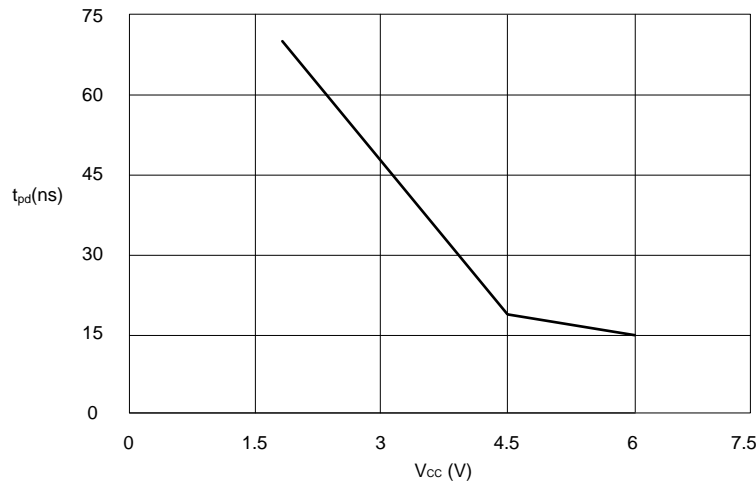

**Figure 5. Typical Propagation Delay -  $\overline{\text{CLR}}$  to Q**

## 10 Power Supply Recommendations

The power supply can be any voltage between the minimum and maximum supply voltage rating located in the [Recommended Operating Conditions](#) table. Each  $V_{CC}$  terminal should have a good bypass capacitor to prevent power disturbance. For devices with a single supply, a 0.1- $\mu\text{F}$  capacitor is recommended and if there are multiple  $V_{CC}$  terminals then .01- $\mu\text{F}$  or .022- $\mu\text{F}$  capacitors are recommended for each power terminal. It is acceptable to parallel multiple bypass caps to reject different frequencies of noise. The 0.1- $\mu\text{F}$  and 1- $\mu\text{F}$  capacitors are commonly used in parallel. The bypass capacitor should be installed as close to the power terminal as possible for best results.

## 11 Layout

### 11.1 Layout Guidelines

When using multiple bit logic devices, inputs should not float. In many cases, functions or parts of functions of digital logic devices are unused. Some examples are when only two inputs of a triple-input AND gate are used, or when only 3 of the 4-buffer gates are used. Such input pins should not be left unconnected because the undefined voltages at the outside connections result in undefined operational states.

Specified in [Figure 6](#) are rules that must be observed under all circumstances. All unused inputs of digital logic devices must be connected to a high or low bias to prevent them from floating. The logic level that must be applied to any particular unused input depends on the function of the device. Generally they are tied to GND or  $V_{CC}$ , whichever makes more sense or is more convenient. It is acceptable to float outputs unless the part is a transceiver. If the transceiver has an output enable pin, it disables the output section of the part when asserted. This pin keeps the input section of the I/Os from being disabled and floated.

### 11.2 Layout Example

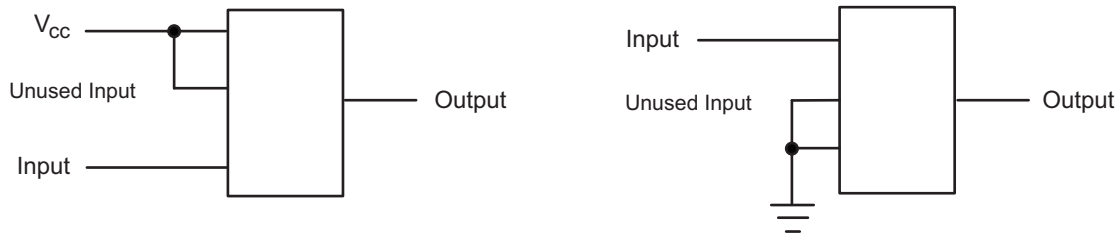

Figure 6. Layout Diagram

## 12 Device and Documentation Support

### 12.1 Documentation Support

#### 12.1.1 Related Documentation

For related documentation, see the following:

*Implications of Slow or Floating CMOS Inputs*, [SCBA004](#)

### 12.2 Related Links

The table below lists quick access links. Categories include technical documents, support and community resources, tools and software, and quick access to sample or buy.

**Table 2. Related Links**

PARTS	PRODUCT FOLDER	SAMPLE & BUY	TECHNICAL DOCUMENTS	TOOLS & SOFTWARE	SUPPORT & COMMUNITY
SN54HC74	<a href="#">Click here</a>	<a href="#">Click here</a>	<a href="#">Click here</a>	<a href="#">Click here</a>	<a href="#">Click here</a>
SN74HC74	<a href="#">Click here</a>	<a href="#">Click here</a>	<a href="#">Click here</a>	<a href="#">Click here</a>	<a href="#">Click here</a>

### 12.3 Community Resources

The following links connect to TI community resources. Linked contents are provided "AS IS" by the respective contributors. They do not constitute TI specifications and do not necessarily reflect TI's views; see TI's [Terms of Use](#).

**TI E2E™ Online Community** *TI's Engineer-to-Engineer (E2E) Community*. Created to foster collaboration among engineers. At [e2e.ti.com](http://e2e.ti.com), you can ask questions, share knowledge, explore ideas and help solve problems with fellow engineers.

**Design Support** *TI's Design Support* Quickly find helpful E2E forums along with design support tools and contact information for technical support.

### 12.4 Trademarks

E2E is a trademark of Texas Instruments.  
All other trademarks are the property of their respective owners.

### 12.5 Electrostatic Discharge Caution



These devices have limited built-in ESD protection. The leads should be shorted together or the device placed in conductive foam during storage or handling to prevent electrostatic damage to the MOS gates.

### 12.6 Glossary

[SLYZ022](#) — *TI Glossary*.

This glossary lists and explains terms, acronyms, and definitions.

## 13 Mechanical, Packaging, and Orderable Information

The following pages include mechanical packaging and orderable information. This information is the most current data available for the designated devices. This data is subject to change without notice and revision of this document. For browser based versions of this data sheet, refer to the left hand navigation.

**PACKAGING INFORMATION**

Orderable Device	Status (1)	Package Type	Package Drawing	Pins	Package Qty	Eco Plan (2)	Lead/Ball Finish (6)	MSL Peak Temp (3)	Op Temp (°C)	Device Marking (4/5)	Samples
5962-8405601VCA	ACTIVE	CDIP	J	14	1	TBD	A42	N / A for Pkg Type	-55 to 125	5962-8405601VC A SNV54HC74J	<a href="#">Samples</a>
5962-8405601VDA	ACTIVE	CFP	W	14	1	TBD	A42	N / A for Pkg Type	-55 to 125	5962-8405601VD A SNV54HC74W	<a href="#">Samples</a>
84056012A	ACTIVE	LCCC	FK	20	1	TBD	POST-PLATE	N / A for Pkg Type	-55 to 125	84056012A SNJ54HC 74FK	<a href="#">Samples</a>
8405601CA	ACTIVE	CDIP	J	14	1	TBD	A42	N / A for Pkg Type	-55 to 125	8405601CA SNJ54HC74J	<a href="#">Samples</a>
8405601DA	ACTIVE	CFP	W	14	1	TBD	A42	N / A for Pkg Type	-55 to 125	8405601DA SNJ54HC74W	<a href="#">Samples</a>
JM38510/65302B2A	ACTIVE	LCCC	FK	20	1	TBD	POST-PLATE	N / A for Pkg Type	-55 to 125	JM38510/ 65302B2A	<a href="#">Samples</a>
JM38510/65302BCA	ACTIVE	CDIP	J	14	1	TBD	A42	N / A for Pkg Type	-55 to 125	JM38510/ 65302BCA	<a href="#">Samples</a>
JM38510/65302BDA	ACTIVE	CFP	W	14	1	TBD	A42	N / A for Pkg Type	-55 to 125	JM38510/ 65302BDA	<a href="#">Samples</a>
M38510/65302B2A	ACTIVE	LCCC	FK	20	1	TBD	POST-PLATE	N / A for Pkg Type	-55 to 125	JM38510/ 65302B2A	<a href="#">Samples</a>
M38510/65302BCA	ACTIVE	CDIP	J	14	1	TBD	A42	N / A for Pkg Type	-55 to 125	JM38510/ 65302BCA	<a href="#">Samples</a>
M38510/65302BDA	ACTIVE	CFP	W	14	1	TBD	A42	N / A for Pkg Type	-55 to 125	JM38510/ 65302BDA	<a href="#">Samples</a>
SN54HC74J	ACTIVE	CDIP	J	14	1	TBD	A42	N / A for Pkg Type	-55 to 125	SN54HC74J	<a href="#">Samples</a>
SN74HC74D	ACTIVE	SOIC	D	14	50	Green (RoHS & no Sb/Br)	CU NIPDAU	Level-1-260C-UNLIM	-40 to 85	HC74	<a href="#">Samples</a>
SN74HC74DBR	ACTIVE	SSOP	DB	14	2000	Green (RoHS & no Sb/Br)	CU NIPDAU	Level-1-260C-UNLIM	-40 to 85	HC74	<a href="#">Samples</a>
SN74HC74DBRG4	ACTIVE	SSOP	DB	14	2000	Green (RoHS & no Sb/Br)	CU NIPDAU	Level-1-260C-UNLIM	-40 to 85	HC74	<a href="#">Samples</a>
SN74HC74DE4	ACTIVE	SOIC	D	14	50	Green (RoHS & no Sb/Br)	CU NIPDAU	Level-1-260C-UNLIM	-40 to 85	HC74	<a href="#">Samples</a>

Orderable Device	Status (1)	Package Type	Package Drawing	Pins	Package Qty	Eco Plan (2)	Lead/Ball Finish (6)	MSL Peak Temp (3)	Op Temp (°C)	Device Marking (4/5)	Samples
SN74HC74DG4	ACTIVE	SOIC	D	14	50	Green (RoHS & no Sb/Br)	CU NIPDAU	Level-1-260C-UNLIM	-40 to 85	HC74	<a href="#">Samples</a>
SN74HC74DR	ACTIVE	SOIC	D	14	2500	Green (RoHS & no Sb/Br)	CU NIPDAU   CU SN	Level-1-260C-UNLIM	-40 to 85	HC74	<a href="#">Samples</a>
SN74HC74DRE4	ACTIVE	SOIC	D	14	2500	Green (RoHS & no Sb/Br)	CU NIPDAU	Level-1-260C-UNLIM	-40 to 85	HC74	<a href="#">Samples</a>
SN74HC74DRG4	ACTIVE	SOIC	D	14	2500	Green (RoHS & no Sb/Br)	CU NIPDAU	Level-1-260C-UNLIM	-40 to 85	HC74	<a href="#">Samples</a>
SN74HC74DT	ACTIVE	SOIC	D	14	250	Green (RoHS & no Sb/Br)	CU NIPDAU	Level-1-260C-UNLIM	-40 to 85	HC74	<a href="#">Samples</a>
SN74HC74N	ACTIVE	PDIP	N	14	25	Green (RoHS & no Sb/Br)	CU NIPDAU	N / A for Pkg Type	-40 to 85	SN74HC74N	<a href="#">Samples</a>
SN74HC74NE4	ACTIVE	PDIP	N	14	25	Green (RoHS & no Sb/Br)	CU NIPDAU	N / A for Pkg Type	-40 to 85	SN74HC74N	<a href="#">Samples</a>
SN74HC74NSR	ACTIVE	SO	NS	14	2000	Green (RoHS & no Sb/Br)	CU NIPDAU	Level-1-260C-UNLIM	-40 to 85	HC74	<a href="#">Samples</a>
SN74HC74PW	ACTIVE	TSSOP	PW	14	90	Green (RoHS & no Sb/Br)	CU NIPDAU	Level-1-260C-UNLIM	-40 to 85	HC74	<a href="#">Samples</a>
SN74HC74PWG4	ACTIVE	TSSOP	PW	14	90	Green (RoHS & no Sb/Br)	CU NIPDAU	Level-1-260C-UNLIM	-40 to 85	HC74	<a href="#">Samples</a>
SN74HC74PWR	ACTIVE	TSSOP	PW	14	2000	Green (RoHS & no Sb/Br)	CU NIPDAU	Level-1-260C-UNLIM	-40 to 85	HC74	<a href="#">Samples</a>
SN74HC74PWRG4	ACTIVE	TSSOP	PW	14	2000	Green (RoHS & no Sb/Br)	CU NIPDAU	Level-1-260C-UNLIM	-40 to 85	HC74	<a href="#">Samples</a>
SN74HC74PWT	ACTIVE	TSSOP	PW	14	250	Green (RoHS & no Sb/Br)	CU NIPDAU	Level-1-260C-UNLIM	-40 to 85	HC74	<a href="#">Samples</a>
SNJ54HC74FK	ACTIVE	LCCC	FK	20	1	TBD	POST-PLATE	N / A for Pkg Type	-55 to 125	84056012A SNJ54HC 74FK	<a href="#">Samples</a>
SNJ54HC74J	ACTIVE	CDIP	J	14	1	TBD	A42	N / A for Pkg Type	-55 to 125	8405601CA SNJ54HC74J	<a href="#">Samples</a>
SNJ54HC74W	ACTIVE	CFP	W	14	1	TBD	A42	N / A for Pkg Type	-55 to 125	8405601DA SNJ54HC74W	<a href="#">Samples</a>

(1) The marketing status values are defined as follows:

**ACTIVE:** Product device recommended for new designs.

**LIFEBUY:** TI has announced that the device will be discontinued, and a lifetime-buy period is in effect.

**NRND:** Not recommended for new designs. Device is in production to support existing customers, but TI does not recommend using this part in a new design.

**PREVIEW:** Device has been announced but is not in production. Samples may or may not be available.

**OBSOLETE:** TI has discontinued the production of the device.

<sup>(2)</sup> **RoHS:** TI defines "RoHS" to mean semiconductor products that are compliant with the current EU RoHS requirements for all 10 RoHS substances, including the requirement that RoHS substance do not exceed 0.1% by weight in homogeneous materials. Where designed to be soldered at high temperatures, "RoHS" products are suitable for use in specified lead-free processes. TI may reference these types of products as "Pb-Free".

**RoHS Exempt:** TI defines "RoHS Exempt" to mean products that contain lead but are compliant with EU RoHS pursuant to a specific EU RoHS exemption.

**Green:** TI defines "Green" to mean the content of Chlorine (Cl) and Bromine (Br) based flame retardants meet JS709B low halogen requirements of  $\leq 1000$ ppm threshold. Antimony trioxide based flame retardants must also meet the  $\leq 1000$ ppm threshold requirement.

<sup>(3)</sup> **MSL, Peak Temp.** - The Moisture Sensitivity Level rating according to the JEDEC industry standard classifications, and peak solder temperature.

<sup>(4)</sup> There may be additional marking, which relates to the logo, the lot trace code information, or the environmental category on the device.

<sup>(5)</sup> Multiple Device Markings will be inside parentheses. Only one Device Marking contained in parentheses and separated by a "~" will appear on a device. If a line is indented then it is a continuation of the previous line and the two combined represent the entire Device Marking for that device.

<sup>(6)</sup> **Lead/Ball Finish** - Orderable Devices may have multiple material finish options. Finish options are separated by a vertical ruled line. Lead/Ball Finish values may wrap to two lines if the finish value exceeds the maximum column width.

**Important Information and Disclaimer:** The information provided on this page represents TI's knowledge and belief as of the date that it is provided. TI bases its knowledge and belief on information provided by third parties, and makes no representation or warranty as to the accuracy of such information. Efforts are underway to better integrate information from third parties. TI has taken and continues to take reasonable steps to provide representative and accurate information but may not have conducted destructive testing or chemical analysis on incoming materials and chemicals. TI and TI suppliers consider certain information to be proprietary, and thus CAS numbers and other limited information may not be available for release.

In no event shall TI's liability arising out of such information exceed the total purchase price of the TI part(s) at issue in this document sold by TI to Customer on an annual basis.

**OTHER QUALIFIED VERSIONS OF SN54HC74, SN54HC74-SP, SN74HC74 :**

- Catalog: [SN74HC74](#), [SN54HC74](#)
- Automotive: [SN74HC74-Q1](#), [SN74HC74-Q1](#)
- Enhanced Product: [SN74HC74-EP](#), [SN74HC74-EP](#)
- Military: [SN54HC74](#)
- Space: [SN54HC74-SP](#)

**NOTE: Qualified Version Definitions:**

- Catalog - TI's standard catalog product
- Automotive - Q100 devices qualified for high-reliability automotive applications targeting zero defects
- Enhanced Product - Supports Defense, Aerospace and Medical Applications
- Military - QML certified for Military and Defense Applications
- Space - Radiation tolerant, ceramic packaging and qualified for use in Space-based application

## TAPE AND REEL INFORMATION



### QUADRANT ASSIGNMENTS FOR PIN 1 ORIENTATION IN TAPE



\*All dimensions are nominal

Device	Package Type	Package Drawing	Pins	SPQ	Reel Diameter (mm)	Reel Width W1 (mm)	A0 (mm)	B0 (mm)	K0 (mm)	P1 (mm)	W (mm)	Pin1 Quadrant
SN74HC74DR	SOIC	D	14	2500	330.0	16.4	6.5	9.0	2.1	8.0	16.0	Q1
SN74HC74DR	SOIC	D	14	2500	330.0	16.4	6.5	9.0	2.1	8.0	16.0	Q1
SN74HC74DR	SOIC	D	14	2500	330.0	16.8	6.5	9.5	2.1	8.0	16.0	Q1
SN74HC74DRG4	SOIC	D	14	2500	330.0	16.4	6.5	9.0	2.1	8.0	16.0	Q1
SN74HC74DRG4	SOIC	D	14	2500	330.0	16.4	6.5	9.0	2.1	8.0	16.0	Q1
SN74HC74DT	SOIC	D	14	250	330.0	16.4	6.5	9.0	2.1	8.0	16.0	Q1
SN74HC74PWR	TSSOP	PW	14	2000	330.0	12.4	6.9	5.6	1.6	8.0	12.0	Q1
SN74HC74PWT	TSSOP	PW	14	250	330.0	12.4	6.9	5.6	1.6	8.0	12.0	Q1

**TAPE AND REEL BOX DIMENSIONS**

\*All dimensions are nominal

Device	Package Type	Package Drawing	Pins	SPQ	Length (mm)	Width (mm)	Height (mm)
SN74HC74DR	SOIC	D	14	2500	333.2	345.9	28.6
SN74HC74DR	SOIC	D	14	2500	367.0	367.0	38.0
SN74HC74DR	SOIC	D	14	2500	364.0	364.0	27.0
SN74HC74DRG4	SOIC	D	14	2500	367.0	367.0	38.0
SN74HC74DRG4	SOIC	D	14	2500	333.2	345.9	28.6
SN74HC74DT	SOIC	D	14	250	210.0	185.0	35.0
SN74HC74PWR	TSSOP	PW	14	2000	367.0	367.0	35.0
SN74HC74PWT	TSSOP	PW	14	250	367.0	367.0	35.0

FK (S-CQCC-N\*\*)

LEADLESS CERAMIC CHIP CARRIER

28 TERMINAL SHOWN



NO. OF TERMINALS **	A		B	
	MIN	MAX	MIN	MAX
20	0.342 (8,69)	0.358 (9,09)	0.307 (7,80)	0.358 (9,09)
28	0.442 (11,23)	0.458 (11,63)	0.406 (10,31)	0.458 (11,63)
44	0.640 (16,26)	0.660 (16,76)	0.495 (12,58)	0.560 (14,22)
52	0.740 (18,78)	0.761 (19,32)	0.495 (12,58)	0.560 (14,22)
68	0.938 (23,83)	0.962 (24,43)	0.850 (21,6)	0.858 (21,8)
84	1.141 (28,99)	1.165 (29,59)	1.047 (26,6)	1.063 (27,0)



4040140/D 01/11

- NOTES:
- All linear dimensions are in inches (millimeters).
  - This drawing is subject to change without notice.
  - This package can be hermetically sealed with a metal lid.
  - Falls within JEDEC MS-004

# MECHANICAL DATA

NS (R-PDSO-G\*\*)

PLASTIC SMALL-OUTLINE PACKAGE

14-PINS SHOWN



- NOTES:
- A. All linear dimensions are in millimeters.
  - B. This drawing is subject to change without notice.
  - C. Body dimensions do not include mold flash or protrusion, not to exceed 0,15.



J 14

**GENERIC PACKAGE VIEW**  
**CDIP - 5.08 mm max height**  
CERAMIC DUAL IN LINE PACKAGE



Images above are just a representation of the package family, actual package may vary.  
Refer to the product data sheet for package details.

4040083-5/G

J0014A



# PACKAGE OUTLINE

CDIP - 5.08 mm max height

CERAMIC DUAL IN LINE PACKAGE



4214771/A 05/2017

NOTES:

1. All controlling linear dimensions are in inches. Dimensions in brackets are in millimeters. Any dimension in brackets or parenthesis are for reference only. Dimensioning and tolerancing per ASME Y14.5M.
2. This drawing is subject to change without notice.
3. This package is hermetically sealed with a ceramic lid using glass frit.
4. Index point is provided on cap for terminal identification only and on press ceramic glass frit seal only.
5. Falls within MIL-STD-1835 and GDIP1-T14.

# EXAMPLE BOARD LAYOUT

J0014A

CDIP - 5.08 mm max height

CERAMIC DUAL IN LINE PACKAGE



LAND PATTERN EXAMPLE  
NON-SOLDER MASK DEFINED  
SCALE: 5X



4214771/A 05/2017

D (R-PDSO-G14)

PLASTIC SMALL OUTLINE



- NOTES:
- A. All linear dimensions are in inches (millimeters).
  - B. This drawing is subject to change without notice.
  -  Body length does not include mold flash, protrusions, or gate burrs. Mold flash, protrusions, or gate burrs shall not exceed 0.006 (0,15) each side.
  -  Body width does not include interlead flash. Interlead flash shall not exceed 0.017 (0,43) each side.
  - E. Reference JEDEC MS-012 variation AB.

D (R-PDSO-G14)

PLASTIC SMALL OUTLINE



4211283-3/E 08/12

- NOTES:
- A. All linear dimensions are in millimeters.
  - B. This drawing is subject to change without notice.
  - C. Publication IPC-7351 is recommended for alternate designs.
  - D. Laser cutting apertures with trapezoidal walls and also rounding corners will offer better paste release. Customers should contact their board assembly site for stencil design recommendations. Refer to IPC-7525 for other stencil recommendations.
  - E. Customers should contact their board fabrication site for solder mask tolerances between and around signal pads.

PW (R-PDSO-G14)

PLASTIC SMALL OUTLINE



- NOTES:
- A. All linear dimensions are in millimeters. Dimensioning and tolerancing per ASME Y14.5M-1994.
  - B. This drawing is subject to change without notice.
  - C. Body length does not include mold flash, protrusions, or gate burrs. Mold flash, protrusions, or gate burrs shall not exceed 0,15 each side.
  - D. Body width does not include interlead flash. Interlead flash shall not exceed 0,25 each side.
  - E. Falls within JEDEC MO-153

PW (R-PDSO-G14)

PLASTIC SMALL OUTLINE



- NOTES:
- All linear dimensions are in millimeters.
  - This drawing is subject to change without notice.
  - Publication IPC-7351 is recommended for alternate designs.
  - Laser cutting apertures with trapezoidal walls and also rounding corners will offer better paste release. Customers should contact their board assembly site for stencil design recommendations. Refer to IPC-7525 for other stencil recommendations.
  - Customers should contact their board fabrication site for solder mask tolerances between and around signal pads.

N (R-PDIP-T\*\*)

PLASTIC DUAL-IN-LINE PACKAGE

16 PINS SHOWN



- NOTES:
- A. All linear dimensions are in inches (millimeters).
  - B. This drawing is subject to change without notice.
  - $\triangle C$  Falls within JEDEC MS-001, except 18 and 20 pin minimum body length (Dim A).
  - $\triangle D$  The 20 pin end lead shoulder width is a vendor option, either half or full width.

4040049/E 12/2002

DB (R-PDSO-G\*\*)

PLASTIC SMALL-OUTLINE

28 PINS SHOWN



- NOTES: A. All linear dimensions are in millimeters.  
 B. This drawing is subject to change without notice.  
 C. Body dimensions do not include mold flash or protrusion not to exceed 0,15.  
 D. Falls within JEDEC MO-150

## IMPORTANT NOTICE AND DISCLAIMER

TI PROVIDES TECHNICAL AND RELIABILITY DATA (INCLUDING DATASHEETS), DESIGN RESOURCES (INCLUDING REFERENCE DESIGNS), APPLICATION OR OTHER DESIGN ADVICE, WEB TOOLS, SAFETY INFORMATION, AND OTHER RESOURCES "AS IS" AND WITH ALL FAULTS, AND DISCLAIMS ALL WARRANTIES, EXPRESS AND IMPLIED, INCLUDING WITHOUT LIMITATION ANY IMPLIED WARRANTIES OF MERCHANTABILITY, FITNESS FOR A PARTICULAR PURPOSE OR NON-INFRINGEMENT OF THIRD PARTY INTELLECTUAL PROPERTY RIGHTS.

These resources are intended for skilled developers designing with TI products. You are solely responsible for (1) selecting the appropriate TI products for your application, (2) designing, validating and testing your application, and (3) ensuring your application meets applicable standards, and any other safety, security, or other requirements. These resources are subject to change without notice. TI grants you permission to use these resources only for development of an application that uses the TI products described in the resource. Other reproduction and display of these resources is prohibited. No license is granted to any other TI intellectual property right or to any third party intellectual property right. TI disclaims responsibility for, and you will fully indemnify TI and its representatives against, any claims, damages, costs, losses, and liabilities arising out of your use of these resources.

TI's products are provided subject to TI's Terms of Sale ([www.ti.com/legal/termsofsale.html](http://www.ti.com/legal/termsofsale.html)) or other applicable terms available either on [ti.com](http://ti.com) or provided in conjunction with such TI products. TI's provision of these resources does not expand or otherwise alter TI's applicable warranties or warranty disclaimers for TI products.

Mailing Address: Texas Instruments, Post Office Box 655303, Dallas, Texas 75265  
Copyright © 2018, Texas Instruments Incorporated

## Looking for pricing, stock, or lifecycle information?

Click below to explore more details on WIN SOURCE:

 [View SN74HC74DR on WIN SOURCE](#)

 [Texas Instruments](#) Information

## Optimize Your Supply Chain with WIN SOURCE Solutions

-  Global Sourcing Solution
-  Obsolete Management
-  Cost Control Management
-  Shortage Management
-  Alternative Solution
-  Excess Inventory Management