



**THE DATASHEET OF  
SN74HC573APWR**





## Table of Contents

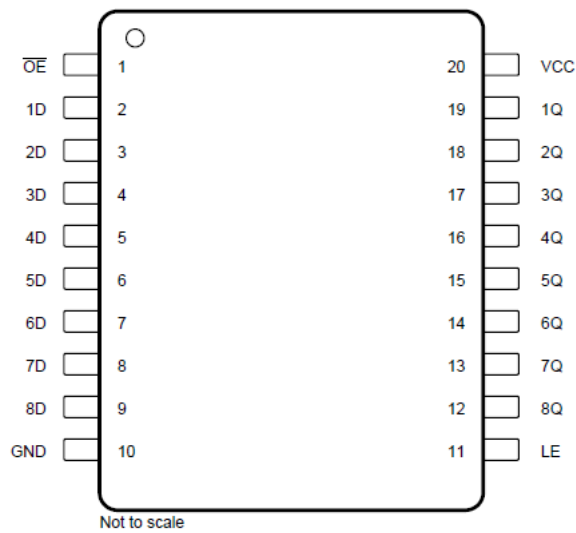
<b>1 Features</b> .....	1	8.3 Feature Description.....	11
<b>2 Applications</b> .....	1	8.4 Device Functional Modes.....	11
<b>3 Description</b> .....	1	<b>9 Application and Implementation</b> .....	12
<b>4 Revision History</b> .....	2	9.1 Application Information.....	12
<b>5 Pin Configuration and Functions</b> .....	3	9.2 Typical Application.....	12
Pin Functions.....	3	<b>10 Power Supply Recommendations</b> .....	13
<b>6 Specifications</b> .....	4	<b>11 Layout</b> .....	14
6.1 Absolute Maximum Ratings.....	4	11.1 Layout Guidelines.....	14
6.2 ESD Ratings.....	4	11.2 Layout Example.....	14
6.3 Recommended Operating Conditions.....	4	<b>12 Device and Documentation Support</b> .....	15
6.4 Thermal Information.....	5	12.1 Documentation Support.....	15
6.5 Electrical Characteristics.....	5	12.2 Related Links.....	15
6.6 Timing Requirements.....	6	12.3 Receiving Notification of Documentation Updates..	15
6.7 Switching Characteristics.....	7	12.4 Support Resources.....	15
6.8 Typical Characteristics.....	9	12.5 Trademarks.....	15
<b>7 Parameter Measurement Information</b> .....	10	12.6 Electrostatic Discharge Caution.....	15
<b>8 Detailed Description</b> .....	11	12.7 Glossary.....	15
8.1 Overview.....	11	<b>13 Mechanical, Packaging, and Orderable Information</b> .....	15
8.2 Functional Block Diagram.....	11		

## 4 Revision History

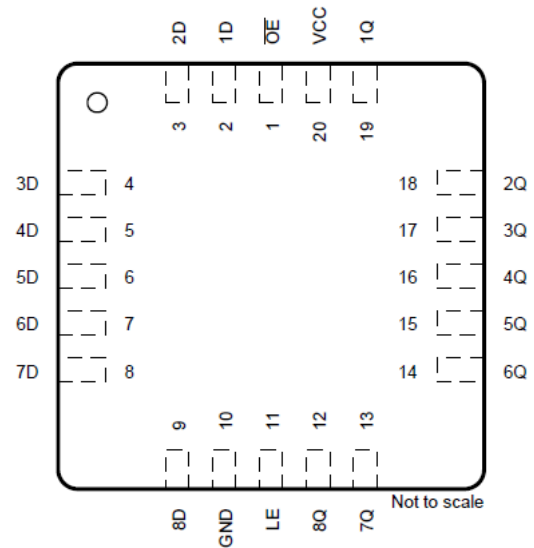
NOTE: Page numbers for previous revisions may differ from page numbers in the current version.

<b>Changes from Revision E (September 2003) to Revision F (October 2016)</b>	<b>Page</b>
• Added <i>ESD Ratings</i> table, <i>Feature Description</i> section, <i>Device Functional Modes</i> , <i>Application and Implementation</i> section, <i>Power Supply Recommendations</i> section, <i>Layout</i> section, <i>Device and Documentation Support</i> section, and <i>Mechanical, Packaging, and Orderable Information</i> section.....	1
• Deleted Ordering Information table; see POA at the end of the data sheet.....	1
• Changed Package thermal impedance, $R_{\theta JA}$ , values from 70 to 92.5 (DB), from 58 to 78.3 (DW), from 69 to 49.1 (N), and from 83 to 101.1 (PW).....	5
<b>Changes from Revision F (October 2016) to Revision G (April 2022)</b>	<b>Page</b>
• Updated ESD ratings table to modern TI standards.....	4
• Changed Package thermal impedance, $R_{\theta JA}$ , values from 92.5 to 122.7 (DB), from 78.3 to 109.1 (DW), from 49.1 to 84.6 (N), and from 101.1 to 131.8 (PW).....	5

## 5 Pin Configuration and Functions



**DB, DW, J, N, PW, or W Packages**  
**20-Pin SSOP, SOIC, CDIP, PDIP, TSSOP, or CFP**  
**Top View**



**FK Package**  
**20-Pin LCCC**  
**Top View**

## Pin Functions

PIN		I/O <sup>(1)</sup>	DESCRIPTION
NO.	NAME		
1	$\overline{OE}$	I	Output enable
2	1D	I	1D input
3	2D	I	2D input
4	3D	I	3D input
5	4D	I	4D input
6	5D	I	5D input
7	6D	I	6D input
8	7D	I	7D input
9	8D	I	8D input
10	GND	—	Ground
11	LE	I	Latch enable input
12	8Q	O	8Q output
13	7Q	O	7Q output
14	6Q	O	6Q output
15	5Q	O	5Q output
16	4Q	O	4Q output
17	3Q	O	3Q output
18	2Q	O	2Q output
19	1Q	O	1Q output
20	V <sub>CC</sub>	—	Power pin

(1) Signal Types: I = Input, O = Output, I/O = Input or Output.

## 6 Specifications

### 6.1 Absolute Maximum Ratings

over operating free-air temperature range (unless otherwise noted)<sup>(1)</sup>

		MIN	MAX	UNIT
V <sub>CC</sub>	Supply voltage	-0.5	7	V
I <sub>IK</sub>	Input clamp current <sup>(2)</sup>	V <sub>I</sub> < 0 or V <sub>I</sub> > V <sub>CC</sub>		±20 mA
I <sub>OK</sub>	Output clamp current <sup>(2)</sup>	V <sub>O</sub> < 0 or V <sub>O</sub> > V <sub>CC</sub>		±20 mA
I <sub>O</sub>	Continuous output current	V <sub>O</sub> = 0 to V <sub>CC</sub>		±35 mA
	Continuous current through V <sub>CC</sub> or GND			±70 mA
T <sub>J</sub>	Junction temperature			150 °C
T <sub>stg</sub>	Storage temperature	-65	150	°C

- (1) Stresses beyond those listed under *Absolute Maximum Ratings* may cause permanent damage to the device. These are stress ratings only, which do not imply functional operation of the device at these or any other conditions beyond those indicated under *Recommended Operating Conditions*. Exposure to absolute-maximum-rated conditions for extended periods may affect device reliability.
- (2) The input and output voltage ratings may be exceeded if the input and output current ratings are observed.

### 6.2 ESD Ratings

		VALUE	UNIT
V <sub>(ESD)</sub>	Electrostatic discharge	Human-body model (HBM), per ANSI/ESDA/JEDEC JS-001 <sup>(1)</sup>	±3500
		Charged device model (CDM), per ANSI/ESDA/JEDEC JS-002 <sup>(2)</sup>	±1000

- (1) JEDEC document JEP155 states that 500-V HBM allows safe manufacturing with a standard ESD control process.
- (2) JEDEC document JEP157 states that 250-V CDM allows safe manufacturing with a standard ESD control process.

### 6.3 Recommended Operating Conditions

over operating free-air temperature range (unless otherwise noted)<sup>(1)</sup>

		MIN	NOM	MAX	UNIT
V <sub>CC</sub>	Supply voltage	2	5	6	V
V <sub>IH</sub>	High-level input voltage	V <sub>CC</sub> = 2 V	1.5		V
		V <sub>CC</sub> = 4.5 V	3.15		
		V <sub>CC</sub> = 6 V	4.2		
V <sub>IL</sub>	Low-level input voltage	V <sub>CC</sub> = 2 V		0.5	V
		V <sub>CC</sub> = 4.5 V		1.35	
		V <sub>CC</sub> = 6 V		1.8	
V <sub>I</sub>	Input voltage	0		V <sub>CC</sub>	V
V <sub>O</sub>	Output voltage	0		V <sub>CC</sub>	V
t <sub>t</sub>	Input transition (rise and fall) time	V <sub>CC</sub> = 2 V		1000	ns
		V <sub>CC</sub> = 4.5 V		500	
		V <sub>CC</sub> = 6 V		400	
T <sub>A</sub>	Operating free-air temperature	SN54HC573A	-55	125	°C
		SN74HC573A	-40	85	

- (1) All unused inputs of the device must be held at V<sub>CC</sub> or GND to ensure proper device operation. See the [Implications of Slow or Floating CMOS Inputs](#) application report (SCBA004).

## 6.4 Thermal Information

THERMAL METRIC		SN74HC573A				UNIT
		DW (SOIC)	DB (SSOP)	N (PDIP)	PW (TSSOP)	
		20 PINS	20 PINS	20 PINS	20 PINS	
$R_{\theta JA}$	Junction-to-ambient thermal resistance <sup>(1)</sup>	109.1	122.7	84.6	131.8	°C/W
$R_{\theta JC (top)}$	Junction-to-case (top) thermal resistance	76	81.6	72.5	72.2	°C/W
$R_{\theta JB}$	Junction-to-board thermal resistance	77.6	77.5	65.3	82.8	°C/W
$\Psi_{JT}$	Junction-to-top characterization parameter	51.5	46.1	55.3	21.5	°C/W
$\Psi_{JB}$	Junction-to-board characterization parameter	77.1	77.1	65.2	82.4	°C/W
$R_{\theta JC (bot)}$	Junction-to-case (bottom) thermal resistance	N/A	N/A	N/A	N/A	°C/W

(1) For more information about traditional and new thermal metrics, see the [Semiconductor and IC Package Thermal Metrics](#) application report.

## 6.5 Electrical Characteristics

over operating free-air temperature range (unless otherwise noted)

PARAMETER	TEST CONDITIONS		MIN	TYP	MAX	UNIT
$V_{OH}$	$V_I = V_{IH} \text{ or } V_{IL}$	$I_{OH} = -20 \mu\text{A}$	$V_{CC} = 2 \text{ V}$	1.9	1.998	V
			$V_{CC} = 4.5 \text{ V}$	4.4	4.499	
			$V_{CC} = 6 \text{ V}$	5.9	5.999	
		$I_{OH} = -6 \text{ mA}, V_{CC} = 4.5 \text{ V}$	$T_A = 25^\circ\text{C}$	3.98	4.3	
			SN54HC573A	3.7		
			SN74HC573A	3.84		
		$I_{OH} = -7.8 \text{ mA}, V_{CC} = 6 \text{ V}$	$T_A = 25^\circ\text{C}$	5.48	5.8	
			SN54HC573A	5.2		
			SN74HC573A	5.34		
$V_{OL}$	$V_I = V_{IH} \text{ or } V_{IL}$	$I_{OL} = 20 \mu\text{A}$	$V_{CC} = 2 \text{ V}$		0.002	0.1
			$V_{CC} = 4.5 \text{ V}$		0.001	0.1
			$V_{CC} = 6 \text{ V}$		0.001	0.1
		$I_{OL} = 6 \text{ mA}, V_{CC} = 4.5 \text{ V}$	$T_A = 25^\circ\text{C}$		0.17	0.26
			SN54HC573A			0.4
			SN74HC573A			0.33
		$I_{OL} = 7.8 \text{ mA}, V_{CC} = 6 \text{ V}$	$T_A = 25^\circ\text{C}$		0.15	0.26
			SN54HC573A			0.4
			SN74HC573A			0.33
$I_I$	$V_I = V_{CC} \text{ or } 0, V_{CC} = 6 \text{ V}$	$T_A = 25^\circ\text{C}$		$\pm 0.1$	$\pm 100$	nA
		SNx4HC573A			$\pm 1000$	
$I_{OZ}$	$V_O = V_{CC} \text{ or } 0, V_{CC} = 6 \text{ V}$	$T_A = 25^\circ\text{C}$		$\pm 0.01$	$\pm 0.5$	$\mu\text{A}$
		SN54HC573A			$\pm 10$	
		SN74HC573A			$\pm 5$	
$I_{CC}$	$V_I = V_{CC} \text{ or } 0, I_O = 0, V_{CC} = 6 \text{ V}$	$T_A = 25^\circ\text{C}$			8	$\mu\text{A}$
		SN54HC573A			160	
		SN74HC573A			80	
$C_i$	$V_{CC} = 2 \text{ V to } 6 \text{ V}$			3	10	pF

**SN54HC573A, SN74HC573A**

SCLS147G – DECEMBER 1982 – REVISED APRIL 2022

over operating free-air temperature range (unless otherwise noted)

PARAMETER	TEST CONDITIONS	MIN	TYP	MAX	UNIT
$C_{pd}$ Power dissipation capacitance per latch	$T_A = 25^\circ\text{C}$ , no load		50		pF

## 6.6 Timing Requirements

over operating free-air temperature range (unless otherwise noted)

			MIN	NOM	MAX	UNIT
$t_w$ Pulse duration, LE high	$V_{CC} = 2\text{ V}$	$T_A = 25^\circ\text{C}$	80			ns
		SN54HC573A	120			
		SN74HC573A	100			
	$V_{CC} = 4.5\text{ V}$	$T_A = 25^\circ\text{C}$	16			
		SN54HC573A	24			
		SN74HC573A	20			
	$V_{CC} = 6\text{ V}$	$T_A = 25^\circ\text{C}$	14			
		SN54HC573A	20			
		SN74HC573A	17			
$t_{su}$ Setup time, data before LE $\downarrow$	$V_{CC} = 2\text{ V}$	$T_A = 25^\circ\text{C}$	50			ns
		SN54HC573A	75			
		SN74HC573A	63			
	$V_{CC} = 4.5\text{ V}$	$T_A = 25^\circ\text{C}$	10			
		SN54HC573A	15			
		SN74HC573A	13			
	$V_{CC} = 6\text{ V}$	$T_A = 25^\circ\text{C}$	9			
		SN54HC573A	13			
		SN74HC573A	11			
$t_h$ Hold time, data after LE $\downarrow$	$V_{CC} = 2\text{ V}$	$T_A = 25^\circ\text{C}$	20			ns
		SNx4HC573A	24			
	$V_{CC} = 4.5\text{ V}$		5			
	$V_{CC} = 6\text{ V}$		5			

## 6.7 Switching Characteristics

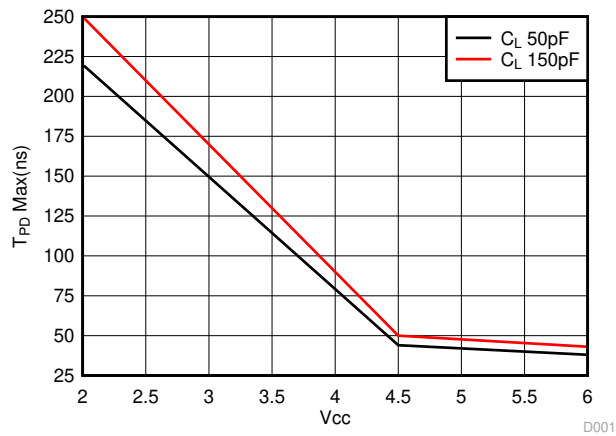
over operating free-air temperature range (unless otherwise noted; see [Figure 7-1](#))

PARAMETER	TEST CONDITIONS		MIN	TYP	MAX	UNIT		
$t_{pd}$	$C_L = 50\text{ pF}$ , from D (input) to Q (output)	$V_{CC} = 2\text{ V}$	$T_A = 25^\circ\text{C}$	77	175	ns		
			SN54HC573A		265			
			SN74HC573A		220			
		$V_{CC} = 4.5\text{ V}$	$T_A = 25^\circ\text{C}$	26	35			
			SN54HC573A		53			
			SN74HC573A		44			
	$V_{CC} = 6\text{ V}$	$T_A = 25^\circ\text{C}$	23	30				
		SN54HC573A		45				
		SN74HC573A		38				
	$C_L = 50\text{ pF}$ , from LE (input) to any Q (output)	$V_{CC} = 2\text{ V}$	$T_A = 25^\circ\text{C}$	87	175			
			SN54HC573A		265			
			SN74HC573A		220			
$V_{CC} = 4.5\text{ V}$		$T_A = 25^\circ\text{C}$	27	35				
		SN54HC573A		53				
		SN74HC573A		44				
$V_{CC} = 6\text{ V}$	$T_A = 25^\circ\text{C}$	23	30					
	SN54HC573A		45					
	SN74HC573A		38					
$t_{en}$	$C_L = 50\text{ pF}$ , from $\overline{OE}$ (input) to any Q (output)	$V_{CC} = 2\text{ V}$	$T_A = 25^\circ\text{C}$	68	150	ns		
			SN54HC573A		225			
			SN74HC573A		190			
		$V_{CC} = 4.5\text{ V}$	$T_A = 25^\circ\text{C}$	24	30			
			SN54HC573A		45			
			SN74HC573A		38			
	$V_{CC} = 6\text{ V}$	$T_A = 25^\circ\text{C}$	21	26				
		SN54HC573A		38				
		SN74HC573A		32				
	$t_{dis}$	$C_L = 50\text{ pF}$ , from $\overline{OE}$ (input) to any Q (output)	$V_{CC} = 2\text{ V}$	$T_A = 25^\circ\text{C}$	47		150	ns
				SN54HC573A			225	
				SN74HC573A			190	
$V_{CC} = 4.5\text{ V}$			$T_A = 25^\circ\text{C}$	23	30			
			SN54HC573A		45			
			SN74HC573A		38			
$V_{CC} = 6\text{ V}$		$T_A = 25^\circ\text{C}$	21	26				
		SN54HC573A		38				
		SN74HC573A		32				

over operating free-air temperature range (unless otherwise noted; see Figure 7-1)

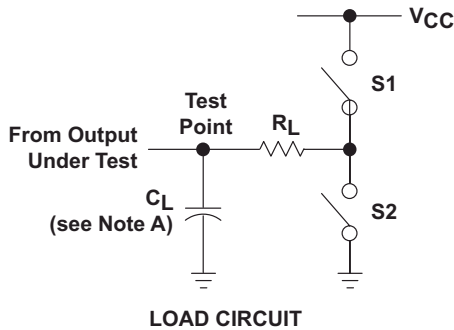
PARAMETER	TEST CONDITIONS		MIN	TYP	MAX	UNIT
$t_t$	$C_L = 50 \text{ pF}$ to any Q (output)	$V_{CC} = 2 \text{ V}$	$T_A = 25^\circ\text{C}$	28	60	ns
			SN54HC573A	90		
			SN74HC573A	75		
		$V_{CC} = 4.5 \text{ V}$	$T_A = 25^\circ\text{C}$	8	12	
			SN54HC573A	18		
			SN74HC573A	15		
		$V_{CC} = 6 \text{ V}$	$T_A = 25^\circ\text{C}$	6	10	
			SN54HC573A	15		
			SN74HC573A	13		
$t_{pd}$	$C_L = 150 \text{ pF}$ , from D (input) to Q (output)	$V_{CC} = 2 \text{ V}$	$T_A = 25^\circ\text{C}$	95	200	ns
			SN54HC573A	300		
			SN74HC573A	250		
		$V_{CC} = 4.5 \text{ V}$	$T_A = 25^\circ\text{C}$	33	40	
			SN54HC573A	60		
			SN74HC573A	50		
		$V_{CC} = 6 \text{ V}$	$T_A = 25^\circ\text{C}$	21	34	
			SN54HC573A	51		
			SN74HC573A	43		
	$C_L = 150 \text{ pF}$ , from LE (input) to any Q (output)	$V_{CC} = 2 \text{ V}$	$T_A = 25^\circ\text{C}$	103	225	
			SN54HC573A	335		
			SN74HC573A	285		
		$V_{CC} = 4.5 \text{ V}$	$T_A = 25^\circ\text{C}$	33	45	
			SN54HC573A	67		
			SN74HC573A	57		
		$V_{CC} = 6 \text{ V}$	$T_A = 25^\circ\text{C}$	29	40	
			SN54HC573A	60		
			SN74HC573A	50		
$t_{en}$	$C_L = 150 \text{ pF}$ , from $\overline{OE}$ (input) to any Q (output)	$V_{CC} = 2 \text{ V}$	$T_A = 25^\circ\text{C}$	85	200	ns
			SN54HC573A	300		
			SN74HC573A	250		
		$V_{CC} = 4.5 \text{ V}$	$T_A = 25^\circ\text{C}$	29	40	
			SN54HC573A	60		
			SN74HC573A	50		
		$V_{CC} = 6 \text{ V}$	$T_A = 25^\circ\text{C}$	26	34	
			SN54HC573A	51		
			SN74HC573A	43		
$t_t$	$C_L = 150 \text{ pF}$ to any Q (output)	$V_{CC} = 2 \text{ V}$	$T_A = 25^\circ\text{C}$	60	210	ns
			SN54HC573A	315		
			SN74HC573A	265		
		$V_{CC} = 4.5 \text{ V}$	$T_A = 25^\circ\text{C}$	17	42	
			SN54HC573A	63		
			SN74HC573A	53		
		$V_{CC} = 6 \text{ V}$	$T_A = 25^\circ\text{C}$	14	36	
			SN54HC573A	53		
			SN74HC573A	45		

## 6.8 Typical Characteristics

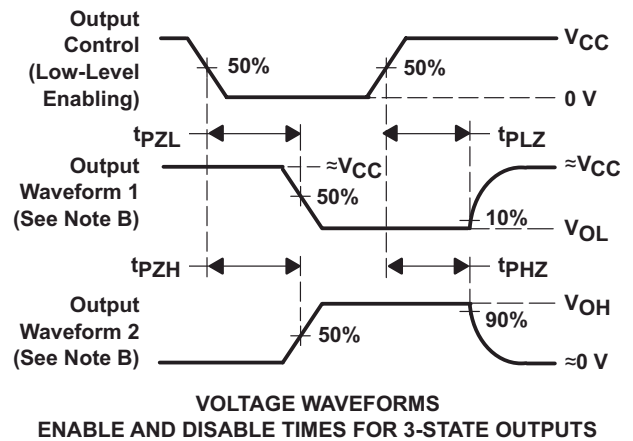
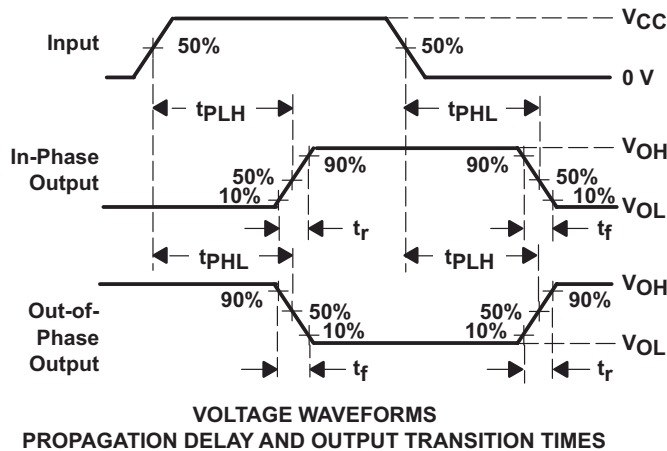
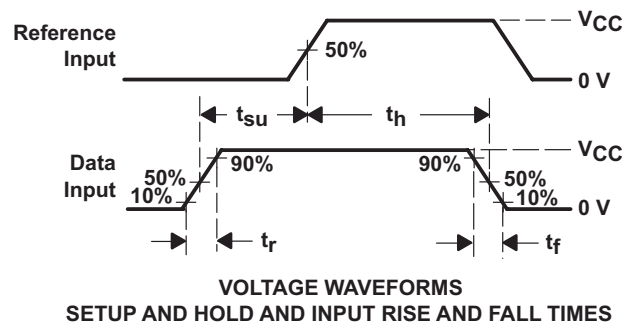
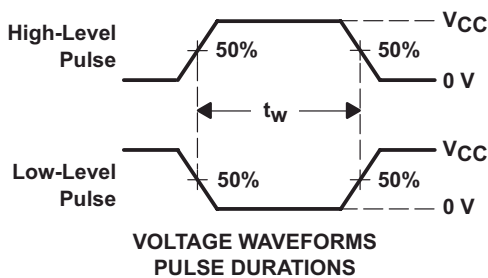


**Figure 6-1. Maximum Propagation Delay Curves**

## 7 Parameter Measurement Information



PARAMETER	$R_L$	$C_L$	S1	S2
$t_{en}$	1 k $\Omega$	50 pF or 150 pF	Open	Closed
			Closed	Open
$t_{dis}$	1 k $\Omega$	50 pF	Open	Closed
			Closed	Open
$t_{pd}$ or $t_t$	--	50 pF or 150 pF	Open	Open



- A.  $C_L$  includes probe and test-fixture capacitance.
- B. Waveform 1 is for an output with internal conditions such that the output is low except when disabled by the output control. Waveform 2 is for an output with internal conditions such that the output is high except when disabled by the output control.
- C. Phase relationships between waveforms were chosen arbitrarily. All input pulses are supplied by generators having the following characteristics:  $PRR \leq 1$  MHz,  $Z_O = 50 \Omega$ ,  $t_r = 6$  ns,  $t_f = 6$  ns.
- D. The outputs are measured one at a time with one input transition per measurement.
- E.  $t_{PLZ}$  and  $t_{PHZ}$  are the same as  $t_{dis}$ .
- F.  $t_{PZL}$  and  $t_{PZH}$  are the same as  $t_{en}$ .
- G.  $t_{PLH}$  and  $t_{PHL}$  are the same as  $t_{pd}$ .

**Figure 7-1. Load Circuit and Voltage Waveforms**

## 8 Detailed Description

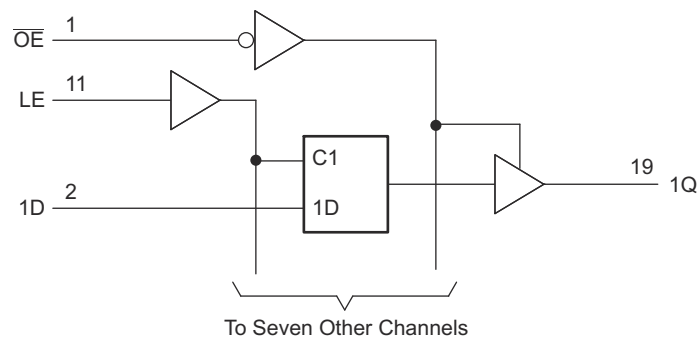
### 8.1 Overview

The SNx4HC573A devices are octal transparent D-type latches that feature 3-state outputs designed specifically for driving highly capacitive or relatively low-impedance loads. A buffered output-enable ( $\overline{OE}$ ) input can be used to place the eight outputs in either a normal logic state (high or low logic levels) or the high-impedance state. In the high-impedance state, the outputs neither load nor drive the bus lines significantly. The high-impedance state and increased drive provide the capability to drive bus lines without interface or pullup components.

To ensure the high-impedance state during power up or power down,  $\overline{OE}$  must be tied to  $V_{CC}$  through a pullup resistor; the minimum value of the resistor is determined by the current-sinking capability of the driver.

$\overline{OE}$  does not affect the internal operations of the latches. Old data can be retained or new data can be entered while the outputs are in the high-impedance state.

### 8.2 Functional Block Diagram



Copyright © 2016, Texas Instruments Incorporated

**Figure 8-1. Logic Diagram (Positive Logic)**

### 8.3 Feature Description

The SNx4HC573A is a high current 3-state output device which can drive bus lines directly or up to 15 LSTTL loads. It has low power consumption up to 80- $\mu$ A maximum  $I_{CC}$ . The high speed CMOS family has typical propagation delay of 21 ns with  $\pm 6$ -mA output drive at 5 V. The input leakage current is a very low 1- $\mu$ A (maximum).

### 8.4 Device Functional Modes

Table 8-1 lists the functional modes of the SNx4HC573A.

**Table 8-1. Function Table (Each Latch)**

INPUTS			OUTPUT
OE	LE	D	Q
L	H	H	H
L	H	L	L
L	L	X	$Q_0$
H	X	X	Hi-Z

## 9 Application and Implementation

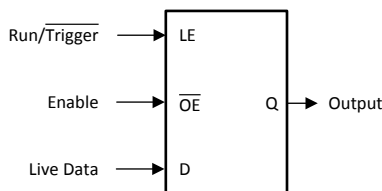
### Note

Information in the following applications sections is not part of the TI component specification, and TI does not warrant its accuracy or completeness. TI's customers are responsible for determining suitability of components for their purposes, as well as validating and testing their design implementation to confirm system functionality.

### 9.1 Application Information

To ensure the high-impedance state during power up or power down,  $\overline{OE}$  must be tied to  $V_{CC}$  through a pullup resistor; the minimum value of the resistor is determined by the current-sinking capability of the driver.  $\overline{OE}$  does not affect the internal operations of the latches. Old data can be retained or new data can be entered while the outputs are in the high-impedance state. The SNx4HC573A latches can be used to store 8 bits of data. [Figure 9-1](#) shows a typical application. A low trigger event latches the output to preserve the event for processing later. With latch input high, this acts as a buffer which follows the live data at the D input when output enable pin held is low.

### 9.2 Typical Application



Copyright © 2016, Texas Instruments Incorporated

**Figure 9-1. Typical Application Schematic**

#### 9.2.1 Design Requirements

The SNx4HC573A device uses CMOS technology and has balanced output drive ( $\pm 7.8$ -mA). Take care to avoid bus contention, because it can drive currents that would exceed maximum limits.

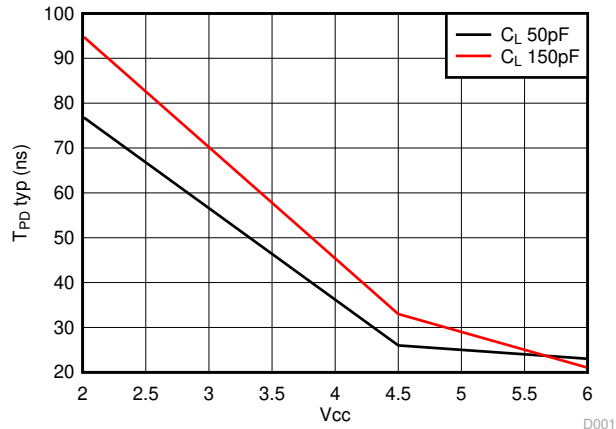
#### 9.2.2 Detailed Design Procedure

Design requirements must adhere to the [Section 6.3](#) and must never exceed the [Section 6.1](#).

The inputs must have a ramp time less than input transition time mentioned in the [Section 6.3](#). Slow inputs can cause oscillations at the output, false triggering, and increased current consumption. TI recommends a Schmitt trigger device like SN74HC14 which can tolerate slower signals.

The inputs and outputs must never exceed  $V_{CC}$  to not forward bias the internal ESD diodes. The maximum frequency supported by this device is 28 MHz.

### 9.2.3 Application Curve



**Figure 9-2. Typical Propagation Delay Curves**

## 10 Power Supply Recommendations

The power supply can be any voltage between the minimum and maximum supply voltage rating located in the [Section 6.3](#) table. The total current through Ground or V<sub>CC</sub> must not exceed ±70 mA as per [Section 6.1](#) table.

Each V<sub>CC</sub> pin must have a good bypass capacitor to prevent power disturbance. For devices with a single supply, TI recommends 0.1-μF capacitor; if there are multiple V<sub>CC</sub> pins, then TI recommends 0.01-μF or 0.022-μF capacitor for each power pin. It is acceptable to parallel multiple bypass capacitors to reject different frequencies of noise. A 0.1-μF and 1-μF capacitor are commonly used in parallel. The bypass capacitor must be installed as close to the power pin as possible for best results.

## 11 Layout

### 11.1 Layout Guidelines

When using multiple-bit logic devices, inputs must never float.

In many cases, functions or parts of functions of digital logic devices are unused, for example, when only two inputs of a triple-input and the gate are used, or only 3 of the 4 buffer gates are used. Such input pins must not be left unconnected because the undefined voltages at the outside connections result in undefined operational states. [Figure 11-1](#) specifies the rules that must be observed under all circumstances. All unused inputs of digital logic devices must be connected to a high or low bias to prevent them from floating. The logic level that must be applied to any particular unused input depends on the function of the device. Generally, they are tied to GND or  $V_{CC}$ , whichever makes more sense or is more convenient. It is acceptable to float outputs, unless the part is a transceiver. If the transceiver has an output enable pin, it disables the output section of the part when asserted. This does not disable the input section of the I/Os, so they cannot float when disabled.

### 11.2 Layout Example

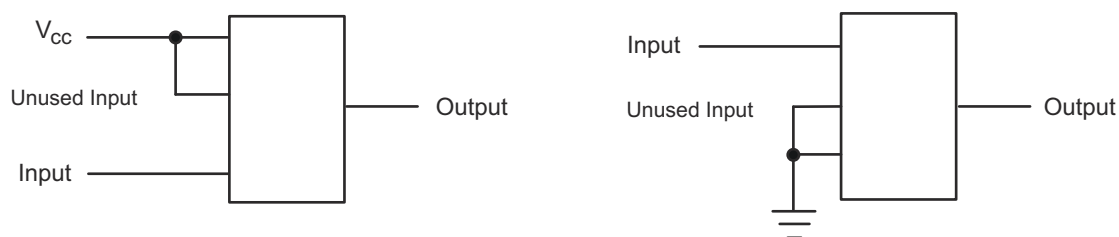


Figure 11-1. Layout Diagram

## 12 Device and Documentation Support

### 12.1 Documentation Support

#### 12.1.1 Related Documentation

For related documentation see the following:

[Implications of Slow or Floating CMOS Inputs](#) (SCBA004)

#### 12.2 Related Links

The table below lists quick access links. Categories include technical documents, support and community resources, tools and software, and quick access to sample or buy.

**Table 12-1. Related Links**

PARTS	PRODUCT FOLDER	SAMPLE & BUY	TECHNICAL DOCUMENTS	TOOLS & SOFTWARE	SUPPORT & COMMUNITY
SN54HC573A	<a href="#">Click here</a>	<a href="#">Click here</a>	<a href="#">Click here</a>	<a href="#">Click here</a>	<a href="#">Click here</a>
SN74HC573A	<a href="#">Click here</a>	<a href="#">Click here</a>	<a href="#">Click here</a>	<a href="#">Click here</a>	<a href="#">Click here</a>

#### 12.3 Receiving Notification of Documentation Updates

To receive notification of documentation updates, navigate to the device product folder on ti.com. In the upper right corner, click on *Alert me* to register and receive a weekly digest of any product information that has changed. For change details, review the revision history included in any revised document.

#### 12.4 Support Resources

[TI E2E™ support forums](#) are an engineer's go-to source for fast, verified answers and design help — straight from the experts. Search existing answers or ask your own question to get the quick design help you need.

Linked content is provided "AS IS" by the respective contributors. They do not constitute TI specifications and do not necessarily reflect TI's views; see TI's [Terms of Use](#).

#### 12.5 Trademarks

TI E2E™ is a trademark of Texas Instruments.

All trademarks are the property of their respective owners.

#### 12.6 Electrostatic Discharge Caution



This integrated circuit can be damaged by ESD. Texas Instruments recommends that all integrated circuits be handled with appropriate precautions. Failure to observe proper handling and installation procedures can cause damage.

ESD damage can range from subtle performance degradation to complete device failure. Precision integrated circuits may be more susceptible to damage because very small parametric changes could cause the device not to meet its published specifications.

#### 12.7 Glossary

[TI Glossary](#) This glossary lists and explains terms, acronyms, and definitions.

## 13 Mechanical, Packaging, and Orderable Information

The following pages include mechanical, packaging, and orderable information. This information is the most current data available for the designated devices. This data is subject to change without notice and revision of this document. For browser-based versions of this data sheet, refer to the left-hand navigation.

**PACKAGING INFORMATION**

Orderable Device	Status (1)	Package Type	Package Drawing	Pins	Package Qty	Eco Plan (2)	Lead finish/ Ball material (6)	MSL Peak Temp (3)	Op Temp (°C)	Device Marking (4/5)	Samples
5962-8512801VRA	ACTIVE	CDIP	J	20	20	Non-RoHS & Green	SNPB	N / A for Pkg Type	-55 to 125	5962-8512801VR A SNV54HC573AJ	<a href="#">Samples</a>
85128012A	ACTIVE	LCCC	FK	20	55	Non-RoHS & Green	SNPB	N / A for Pkg Type	-55 to 125	85128012A SNJ54HC 573AFK	<a href="#">Samples</a>
8512801RA	ACTIVE	CDIP	J	20	20	Non-RoHS & Green	SNPB	N / A for Pkg Type	-55 to 125	8512801RA SNJ54HC573AJ	<a href="#">Samples</a>
8512801SA	ACTIVE	CFP	W	20	25	Non-RoHS & Green	SNPB	N / A for Pkg Type	-55 to 125	8512801SA SNJ54HC573AW	<a href="#">Samples</a>
JM38510/65406BRA	ACTIVE	CDIP	J	20	20	Non-RoHS & Green	SNPB	N / A for Pkg Type	-55 to 125	JM38510/ 65406BRA	<a href="#">Samples</a>
M38510/65406BRA	ACTIVE	CDIP	J	20	20	Non-RoHS & Green	SNPB	N / A for Pkg Type	-55 to 125	JM38510/ 65406BRA	<a href="#">Samples</a>
SN54HC573AJ	ACTIVE	CDIP	J	20	20	Non-RoHS & Green	SNPB	N / A for Pkg Type	-55 to 125	SN54HC573AJ	<a href="#">Samples</a>
SN74HC573ADBR	ACTIVE	SSOP	DB	20	2000	RoHS & Green	NIPDAU	Level-1-260C-UNLIM	-40 to 85	HC573A	<a href="#">Samples</a>
SN74HC573ADWR	ACTIVE	SOIC	DW	20	2000	RoHS & Green	NIPDAU	Level-1-260C-UNLIM	-40 to 85	HC573A	<a href="#">Samples</a>
SN74HC573ADWRG4	ACTIVE	SOIC	DW	20	2000	RoHS & Green	NIPDAU	Level-1-260C-UNLIM	-40 to 85	HC573A	<a href="#">Samples</a>
SN74HC573AN	ACTIVE	PDIP	N	20	20	RoHS & Green	NIPDAU	N / A for Pkg Type	-40 to 85	SN74HC573AN	<a href="#">Samples</a>
SN74HC573ANE4	ACTIVE	PDIP	N	20	20	RoHS & Green	NIPDAU	N / A for Pkg Type	-40 to 85	SN74HC573AN	<a href="#">Samples</a>
SN74HC573APWR	ACTIVE	TSSOP	PW	20	2000	RoHS & Green	NIPDAU	Level-1-260C-UNLIM	-40 to 85	HC573A	<a href="#">Samples</a>
SN74HC573APWRG4	ACTIVE	TSSOP	PW	20	2000	RoHS & Green	NIPDAU	Level-1-260C-UNLIM	-40 to 85	HC573A	<a href="#">Samples</a>
SNJ54HC573AFK	ACTIVE	LCCC	FK	20	55	Non-RoHS & Green	SNPB	N / A for Pkg Type	-55 to 125	85128012A SNJ54HC 573AFK	<a href="#">Samples</a>
SNJ54HC573AJ	ACTIVE	CDIP	J	20	20	Non-RoHS & Green	SNPB	N / A for Pkg Type	-55 to 125	8512801RA SNJ54HC573AJ	<a href="#">Samples</a>

Orderable Device	Status (1)	Package Type	Package Drawing	Pins	Package Qty	Eco Plan (2)	Lead finish/ Ball material (6)	MSL Peak Temp (3)	Op Temp (°C)	Device Marking (4/5)	Samples
SNJ54HC573AW	ACTIVE	CFP	W	20	25	Non-RoHS & Green	SNPB	N / A for Pkg Type	-55 to 125	8512801SA SNJ54HC573AW	Samples

(1) The marketing status values are defined as follows:

**ACTIVE:** Product device recommended for new designs.

**LIFEBUY:** TI has announced that the device will be discontinued, and a lifetime-buy period is in effect.

**NRND:** Not recommended for new designs. Device is in production to support existing customers, but TI does not recommend using this part in a new design.

**PREVIEW:** Device has been announced but is not in production. Samples may or may not be available.

**OBSOLETE:** TI has discontinued the production of the device.

(2) **RoHS:** TI defines "RoHS" to mean semiconductor products that are compliant with the current EU RoHS requirements for all 10 RoHS substances, including the requirement that RoHS substance do not exceed 0.1% by weight in homogeneous materials. Where designed to be soldered at high temperatures, "RoHS" products are suitable for use in specified lead-free processes. TI may reference these types of products as "Pb-Free".

**RoHS Exempt:** TI defines "RoHS Exempt" to mean products that contain lead but are compliant with EU RoHS pursuant to a specific EU RoHS exemption.

**Green:** TI defines "Green" to mean the content of Chlorine (Cl) and Bromine (Br) based flame retardants meet JS709B low halogen requirements of <=1000ppm threshold. Antimony trioxide based flame retardants must also meet the <=1000ppm threshold requirement.

(3) MSL, Peak Temp. - The Moisture Sensitivity Level rating according to the JEDEC industry standard classifications, and peak solder temperature.

(4) There may be additional marking, which relates to the logo, the lot trace code information, or the environmental category on the device.

(5) Multiple Device Markings will be inside parentheses. Only one Device Marking contained in parentheses and separated by a "~" will appear on a device. If a line is indented then it is a continuation of the previous line and the two combined represent the entire Device Marking for that device.

(6) Lead finish/Ball material - Orderable Devices may have multiple material finish options. Finish options are separated by a vertical ruled line. Lead finish/Ball material values may wrap to two lines if the finish value exceeds the maximum column width.

**Important Information and Disclaimer:**The information provided on this page represents TI's knowledge and belief as of the date that it is provided. TI bases its knowledge and belief on information provided by third parties, and makes no representation or warranty as to the accuracy of such information. Efforts are underway to better integrate information from third parties. TI has taken and continues to take reasonable steps to provide representative and accurate information but may not have conducted destructive testing or chemical analysis on incoming materials and chemicals. TI and TI suppliers consider certain information to be proprietary, and thus CAS numbers and other limited information may not be available for release.

In no event shall TI's liability arising out of such information exceed the total purchase price of the TI part(s) at issue in this document sold by TI to Customer on an annual basis.

**OTHER QUALIFIED VERSIONS OF SN54HC573A, SN54HC573A-SP, SN74HC573A :**

- Catalog : [SN74HC573A](#), [SN54HC573A](#)
- Automotive : [SN74HC573A-Q1](#), [SN74HC573A-Q1](#)
- Military : [SN54HC573A](#)
- Space : [SN54HC573A-SP](#)

NOTE: Qualified Version Definitions:

- Catalog - TI's standard catalog product
- Automotive - Q100 devices qualified for high-reliability automotive applications targeting zero defects
- Military - QML certified for Military and Defense Applications
- Space - Radiation tolerant, ceramic packaging and qualified for use in Space-based application

**TAPE AND REEL INFORMATION**

**QUADRANT ASSIGNMENTS FOR PIN 1 ORIENTATION IN TAPE**


\*All dimensions are nominal

Device	Package Type	Package Drawing	Pins	SPQ	Reel Diameter (mm)	Reel Width W1 (mm)	A0 (mm)	B0 (mm)	K0 (mm)	P1 (mm)	W (mm)	Pin1 Quadrant
SN74HC573ADBR	SSOP	DB	20	2000	330.0	16.4	8.2	7.5	2.5	12.0	16.0	Q1
SN74HC573ADWR	SOIC	DW	20	2000	330.0	24.4	10.9	13.3	2.7	12.0	24.0	Q1
SN74HC573ADWR	SOIC	DW	20	2000	330.0	24.4	10.9	13.3	2.7	12.0	24.0	Q1
SN74HC573APWR	TSSOP	PW	20	2000	330.0	16.4	6.95	7.0	1.4	8.0	16.0	Q1
SN74HC573APWR	TSSOP	PW	20	2000	330.0	16.4	6.95	7.0	1.4	8.0	16.0	Q1

**TAPE AND REEL BOX DIMENSIONS**


\*All dimensions are nominal

Device	Package Type	Package Drawing	Pins	SPQ	Length (mm)	Width (mm)	Height (mm)
SN74HC573ADBR	SSOP	DB	20	2000	356.0	356.0	35.0
SN74HC573ADWR	SOIC	DW	20	2000	367.0	367.0	45.0
SN74HC573ADWR	SOIC	DW	20	2000	367.0	367.0	45.0
SN74HC573APWR	TSSOP	PW	20	2000	356.0	356.0	35.0
SN74HC573APWR	TSSOP	PW	20	2000	356.0	356.0	35.0

**TUBE**


\*All dimensions are nominal

Device	Package Name	Package Type	Pins	SPQ	L (mm)	W (mm)	T (μm)	B (mm)
85128012A	FK	LCCC	20	55	506.98	12.06	2030	NA
8512801SA	W	CFP	20	25	506.98	26.16	6220	NA
SN74HC573AN	N	PDIP	20	20	506	13.97	11230	4.32
SN74HC573ANE4	N	PDIP	20	20	506	13.97	11230	4.32
SNJ54HC573AFK	FK	LCCC	20	55	506.98	12.06	2030	NA
SNJ54HC573AW	W	CFP	20	25	506.98	26.16	6220	NA

W (R-GDFP-F20)

CERAMIC DUAL FLATPACK



- NOTES:
- A. All linear dimensions are in inches (millimeters).
  - B. This drawing is subject to change without notice.
  - C. This package can be hermetically sealed with a ceramic lid using glass frit.
  - D. Index point is provided on cap for terminal identification only.
  - E. Falls within Mil-Std 1835 GDFP2-F20

# PW0020A



# PACKAGE OUTLINE

## TSSOP - 1.2 mm max height

SMALL OUTLINE PACKAGE



4220206/A 02/2017

### NOTES:

1. All linear dimensions are in millimeters. Any dimensions in parenthesis are for reference only. Dimensioning and tolerancing per ASME Y14.5M.
2. This drawing is subject to change without notice.
3. This dimension does not include mold flash, protrusions, or gate burrs. Mold flash, protrusions, or gate burrs shall not exceed 0.15 mm per side.
4. This dimension does not include interlead flash. Interlead flash shall not exceed 0.25 mm per side.
5. Reference JEDEC registration MO-153.

# EXAMPLE BOARD LAYOUT

PW0020A

TSSOP - 1.2 mm max height

SMALL OUTLINE PACKAGE



LAND PATTERN EXAMPLE  
EXPOSED METAL SHOWN  
SCALE: 10X



SOLDER MASK DETAILS

4220206/A 02/2017

NOTES: (continued)

- 6. Publication IPC-7351 may have alternate designs.
- 7. Solder mask tolerances between and around signal pads can vary based on board fabrication site.

# EXAMPLE STENCIL DESIGN

PW0020A

TSSOP - 1.2 mm max height

SMALL OUTLINE PACKAGE



SOLDER PASTE EXAMPLE  
BASED ON 0.125 mm THICK STENCIL  
SCALE: 10X

4220206/A 02/2017

NOTES: (continued)

8. Laser cutting apertures with trapezoidal walls and rounded corners may offer better paste release. IPC-7525 may have alternate design recommendations.
9. Board assembly site may have different recommendations for stencil design.

# DB0020A



# PACKAGE OUTLINE

## SSOP - 2 mm max height

SMALL OUTLINE PACKAGE



4214851/B 08/2019

### NOTES:

1. All linear dimensions are in millimeters. Any dimensions in parenthesis are for reference only. Dimensioning and tolerancing per ASME Y14.5M.
2. This drawing is subject to change without notice.
3. This dimension does not include mold flash, protrusions, or gate burrs. Mold flash, protrusions, or gate burrs shall not exceed 0.15 mm per side.
4. This dimension does not include interlead flash. Interlead flash shall not exceed 0.25 mm per side.
5. Reference JEDEC registration MO-150.

# EXAMPLE BOARD LAYOUT

DB0020A

SSOP - 2 mm max height

SMALL OUTLINE PACKAGE



LAND PATTERN EXAMPLE  
EXPOSED METAL SHOWN  
SCALE: 10X



4214851/B 08/2019

NOTES: (continued)

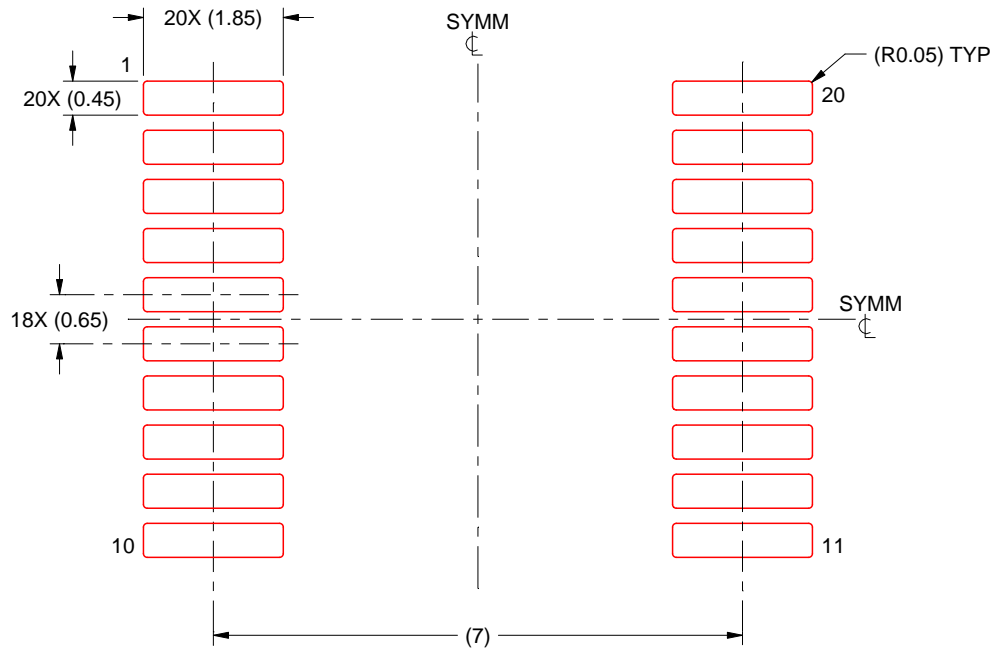
- 6. Publication IPC-7351 may have alternate designs.
- 7. Solder mask tolerances between and around signal pads can vary based on board fabrication site.

# EXAMPLE STENCIL DESIGN

DB0020A

SSOP - 2 mm max height

SMALL OUTLINE PACKAGE



SOLDER PASTE EXAMPLE  
BASED ON 0.125 mm THICK STENCIL  
SCALE: 10X

4214851/B 08/2019

NOTES: (continued)

8. Laser cutting apertures with trapezoidal walls and rounded corners may offer better paste release. IPC-7525 may have alternate design recommendations.
9. Board assembly site may have different recommendations for stencil design.



## GENERIC PACKAGE VIEW

**FK 20**

**LCCC - 2.03 mm max height**

8.89 x 8.89, 1.27 mm pitch

LEADLESS CERAMIC CHIP CARRIER

This image is a representation of the package family, actual package may vary.  
Refer to the product data sheet for package details.



4229370VA\

N (R-PDIP-T\*\*)

PLASTIC DUAL-IN-LINE PACKAGE

16 PINS SHOWN



- NOTES:
- A. All linear dimensions are in inches (millimeters).
  - B. This drawing is subject to change without notice.
  - Falls within JEDEC MS-001, except 18 and 20 pin minimum body length (Dim A).
  - The 20 pin end lead shoulder width is a vendor option, either half or full width.



# EXAMPLE BOARD LAYOUT

DW0020A

SOIC - 2.65 mm max height

SOIC



LAND PATTERN EXAMPLE  
SCALE:6X



SOLDER MASK DETAILS

4220724/A 05/2016

NOTES: (continued)

- 6. Publication IPC-7351 may have alternate designs.
- 7. Solder mask tolerances between and around signal pads can vary based on board fabrication site.

# EXAMPLE STENCIL DESIGN

DW0020A

SOIC - 2.65 mm max height

SOIC



SOLDER PASTE EXAMPLE  
BASED ON 0.125 mm THICK STENCIL  
SCALE:6X

4220724/A 05/2016

NOTES: (continued)

8. Laser cutting apertures with trapezoidal walls and rounded corners may offer better paste release. IPC-7525 may have alternate design recommendations.
9. Board assembly site may have different recommendations for stencil design.

## IMPORTANT NOTICE AND DISCLAIMER

TI PROVIDES TECHNICAL AND RELIABILITY DATA (INCLUDING DATA SHEETS), DESIGN RESOURCES (INCLUDING REFERENCE DESIGNS), APPLICATION OR OTHER DESIGN ADVICE, WEB TOOLS, SAFETY INFORMATION, AND OTHER RESOURCES "AS IS" AND WITH ALL FAULTS, AND DISCLAIMS ALL WARRANTIES, EXPRESS AND IMPLIED, INCLUDING WITHOUT LIMITATION ANY IMPLIED WARRANTIES OF MERCHANTABILITY, FITNESS FOR A PARTICULAR PURPOSE OR NON-INFRINGEMENT OF THIRD PARTY INTELLECTUAL PROPERTY RIGHTS.

These resources are intended for skilled developers designing with TI products. You are solely responsible for (1) selecting the appropriate TI products for your application, (2) designing, validating and testing your application, and (3) ensuring your application meets applicable standards, and any other safety, security, regulatory or other requirements.

These resources are subject to change without notice. TI grants you permission to use these resources only for development of an application that uses the TI products described in the resource. Other reproduction and display of these resources is prohibited. No license is granted to any other TI intellectual property right or to any third party intellectual property right. TI disclaims responsibility for, and you will fully indemnify TI and its representatives against, any claims, damages, costs, losses, and liabilities arising out of your use of these resources.

TI's products are provided subject to [TI's Terms of Sale](#) or other applicable terms available either on [ti.com](https://www.ti.com) or provided in conjunction with such TI products. TI's provision of these resources does not expand or otherwise alter TI's applicable warranties or warranty disclaimers for TI products.

TI objects to and rejects any additional or different terms you may have proposed.

Mailing Address: Texas Instruments, Post Office Box 655303, Dallas, Texas 75265  
Copyright © 2023, Texas Instruments Incorporated

## Looking for pricing, stock, or lifecycle information?

Click below to explore more details on WIN SOURCE:

 [View SN74HC573APWR on WIN SOURCE](#)

 [Texas Instruments](#) Information

## Optimize Your Supply Chain with WIN SOURCE Solutions

-  Global Sourcing Solution
-  Obsolete Management
-  Cost Control Management
-  Shortage Management
-  Alternative Solution
-  Excess Inventory Management