



**THE DATASHEET OF
SN74GTL1655DGGR**



FEATURES

- Member of the Texas Instruments Widebus™ Family
- UBT™ Transceiver Combines D-Type Latches and D-Type Flip-Flops for Operation in Transparent, Latched, or Clocked Modes
- OEC™ Circuitry Improves Signal Integrity and Reduces Electromagnetic Interference
- Translates Between GTL/GTL+ Signal Level and LVTTTL Logic Levels
- High-Drive (100 mA), Low-Output-Impedance (12 Ω) Bus Transceiver (B Port)
- Edge-Rate-Control Input Configures the B-Port Output Rise and Fall Times
- I_{off}, Power-Up 3-State, and BIAS V_{CC} Support Live Insertion
- Bus Hold on Data Inputs Eliminates the Need for External Pullup/Pulldown Resistors on A Port
- Distributed V_{CC} and GND Pins Minimize High-Speed Switching Noise

DESCRIPTION/ORDERING INFORMATION

The SN74GTL1655 is a high-drive (100 mA), low-output-impedance (12 Ω) 16-bit UBT™ transceiver that provides LVTTTL-to-GTL/GTL+ and GTL/GTL+-to-LVTTTL signal-level translation. This device is partitioned as two 8-bit transceivers and combines D-type flip-flops and D-type latches to allow for transparent, latched, and clocked modes of data transfer similar to the '16501 function. This device provides an interface between cards operating at LVTTTL logic levels and a backplane operating at GTL/GTL+ signal levels. Higher-speed operation is a direct result of the reduced output swing (<1 V), reduced input threshold levels, and OEC™ circuitry. The high drive is suitable for driving double-terminated low-impedance backplanes using incident-wave switching.

The user has the flexibility of using this device at either GTL (V_{TT} = 1.2 V and V_{REF} = 0.8 V) or the preferred higher noise margin GTL+ (V_{TT} = 1.5 V and V_{REF} = 1 V) signal levels. GTL+ is the Texas Instruments derivative of the Gunning Transceiver Logic (GTL) JEDEC standard JESD 8-3. The B port normally operates at GTL or GTL+ signal levels, while the A-port and control inputs are compatible with LVTTTL logic levels, but are not 5-V tolerant. V_{REF} is the reference input voltage for the B port.

**DGG PACKAGE
(TOP VIEW)**

$\overline{1OEAB}$	1	64	CLK
$\overline{1OEBA}$	2	63	1LEAB
V _{CC}	3	62	1LEBA
1A1	4	61	V _{ERC}
GND	5	60	GND
1A2	6	59	1B1
1A3	7	58	1B2
GND	8	57	GND
1A4	9	56	1B3
GND	10	55	1B4
1A5	11	54	1B5
GND	12	53	GND
1A6	13	52	1B6
1A7	14	51	1B7
V _{CC}	15	50	V _{CC}
1A8	16	49	1B8
2A1	17	48	2B1
GND	18	47	GND
2A2	19	46	2B2
2A3	20	45	2B3
GND	21	44	GND
2A4	22	43	2B4
2A5	23	42	2B5
GND	24	41	V _{REF}
2A6	25	40	2B6
GND	26	39	GND
2A7	27	38	2B7
V _{CC}	28	37	2B8
2A8	29	36	BIAS V _{CC}
GND	30	35	2LEAB
$\overline{2OEAB}$	31	34	2LEBA
$\overline{2OEBA}$	32	33	\overline{OE}



Please be aware that an important notice concerning availability, standard warranty, and use in critical applications of Texas Instruments semiconductor products and disclaimers thereto appears at the end of this data sheet.

Widebus, UBT, OEC are trademarks of Texas Instruments.

SN74GTL1655

16-BIT LVTTTL-TO-GTL/GTL+ UNIVERSAL BUS TRANSCEIVER WITH LIVE INSERTION

SCBS696I–JULY 1997–REVISED APRIL 2005

DESCRIPTION/ORDERING INFORMATION (CONTINUED)

This device is partitioned uniquely as two 8-bit transceivers with individual latch timing and output signals, but with a common clock and output enable inputs for both transceiver words.

Data flow for each word is determined by the respective latch enables (LEAB and LEBA), output enables (\overline{OEAB} and \overline{OEBA}), and clock (CLK). The output enables ($1\overline{OEAB}$, $1\overline{OEBA}$, $2\overline{OEAB}$, and $2\overline{OEBA}$) control byte 1 and byte 2 data for the A-to-B and B-to-A directions, respectively.

For A-to-B data flow, the devices operate in the transparent mode when LEAB is high. When LEAB transitions low, the A data is latched independent of CLK high or low. If LEAB is low, the A data is registered on the CLK low-to-high transition. When \overline{OEAB} is low, the outputs are active. With \overline{OEAB} high, the outputs are in the high-impedance state.

Data flow for the B-to-A direction is identical, but uses \overline{OEBA} , LEBA, and CLK. Note that CLK is common to both directions and both 8-bit words. \overline{OE} also is common and is used to disable all I/O ports simultaneously.

The SN74GTL1655 has adjustable edge-rate control (V_{ERC}). Changing V_{ERC} input voltage between GND and V_{CC} adjusts the B-port output rise and fall times. This allows the designer to optimize for various loading conditions.

This device is fully specified for live-insertion applications using I_{off} , power-up 3-state, and BIAS V_{CC} . The I_{off} circuitry disables the outputs, preventing damaging current backflow through the device when it is powered down. The power-up 3-state circuitry places the outputs in the high-impedance state during power up and power down, which prevents driver conflict. The BIAS V_{CC} circuitry precharges and preconditions the B-port input/output connections, preventing disturbance of active data on the backplane during card insertion or removal, and permits true live-insertion capability.

When V_{CC} is between 0 and 1.5 V, the device is in the high-impedance state during power up or power down. However, to ensure the high-impedance state above 1.5 V, \overline{OE} should be tied to V_{CC} through a pullup resistor; the minimum value of the resistor is determined by the current-sinking capability of the driver.

Active bus-hold circuitry holds unused or undriven LVTTTL inputs at a valid logic state. Use of pullup or pulldown resistors with the bus-hold circuitry is not recommended.

ORDERING INFORMATION

T_A	PACKAGE ⁽¹⁾		ORDERABLE PART NUMBER	TOP-SIDE MARKING
–40°C to 85°C	TSSOP – DGG	Tape and reel	SN74GTL1655DGGR	GTL1655

(1) Package drawings, standard packing quantities, thermal data, symbolization, and PCB design guidelines are available at www.ti.com/sc/package.

FUNCTION TABLES

FUNCTION⁽¹⁾

INPUTS				OUTPUT B	MODE
\overline{OEAB}	LEAB	CLK	A		
H	X	X	X	Z	Isolation
L	H	X	L	L	Transparent
L	H	X	H	H	Transparent
L	L	↑	L	L	Registered
L	L	↑	H	H	Registered
L	L	H	X	B ₀ ⁽²⁾	Previous state
L	L	L	X	B ₀ ⁽³⁾	Previous state

- (1) A-to-B data flow is shown. B-to-A flow is similar, but uses \overline{OEBA} , LEBA, and CLK.
- (2) Output level before the indicated steady-state input conditions were established, provided that CLK was high before LEAB went low
- (3) Output level before the indicated steady-state input conditions were established

OUTPUT ENABLE

INPUTS			OUTPUTS	
\overline{OE}	\overline{OEAB}	\overline{OEBA}	A PORT	B PORT
L	L	L	Active	Active
L	L	H	Z	Active
L	H	L	Active	Z
L	H	H	Z	Z
H	X	X	Z	Z

B-PORT EDGE-RATE CONTROL (V_{ERC})

input V_{ERC}		OUTPUT B-PORT EDGE RATE
LOGIC LEVEL	NOMINAL VOLTAGE	
H	V_{CC}	Slow
L	GND	Fast

SN74GTL1655
16-BIT LVTTTL-TO-GTL/GTL+ UNIVERSAL BUS TRANSCEIVER
WITH LIVE INSERTION

SCBS696I—JULY 1997—REVISED APRIL 2005

LOGIC DIAGRAM (POSITIVE LOGIC)

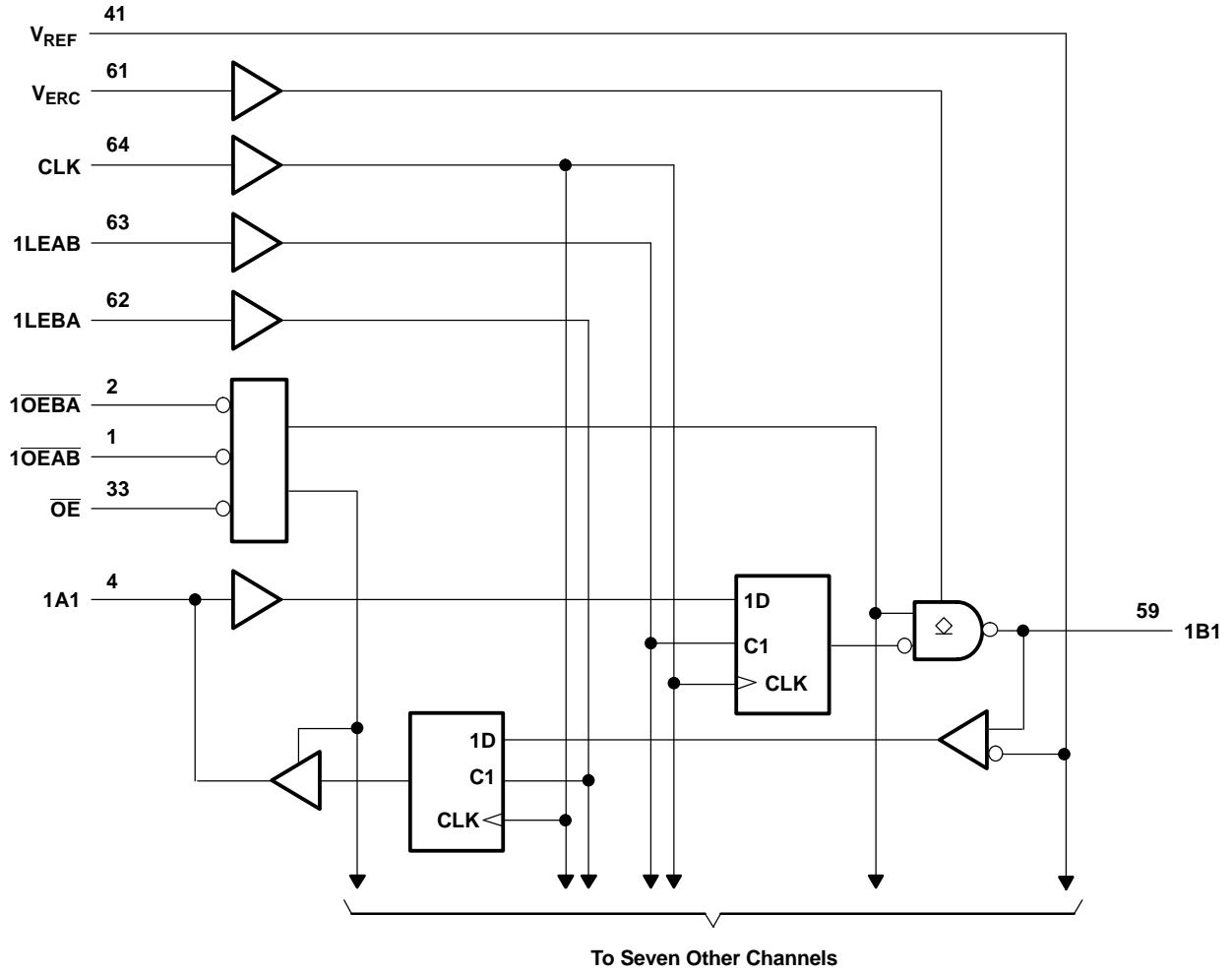

SN74GTL1655

16-BIT LVTTTL-TO-GTL/GTL+ UNIVERSAL BUS TRANSCEIVER WITH LIVE INSERTION



SCBS696I–JULY 1997–REVISED APRIL 2005

Absolute Maximum Ratings⁽¹⁾

over operating free-air temperature range (unless otherwise noted)

		MIN	MAX	UNIT	
V_{CC} BIAS V_{CC}	Supply voltage range	–0.5	4.6	V	
V_I	Input voltage range ⁽²⁾	A-port and control inputs	–0.5	4.6	V
		B port, V_{ERC} , and V_{REF}	–0.5	4.6	
V_O	Voltage range applied to any output in the high or power-off state ⁽²⁾	A port	–0.5	4.6	V
		B port	–0.5	4.6	
I_O	Current into any output in the low state	A port		48	mA
		B port		200	
I_O	Current into any A-port output in the high state ⁽³⁾		48	mA	
	Continuous current through each V_{CC} or GND		±100	mA	
I_{IK}	Input clamp current	$V_I < 0$	–50	mA	
I_{OK}	Output clamp current	$V_O < 0$	–50	mA	
θ_{JA}	Package thermal impedance ⁽⁴⁾		55	°C/W	
T_{stg}	Storage temperature range	–65	150	°C	

- (1) Stresses beyond those listed under "absolute maximum ratings" may cause permanent damage to the device. These are stress ratings only, and functional operation of the device at these or any other conditions beyond those indicated under "recommended operating conditions" is not implied. Exposure to absolute-maximum-rated conditions for extended periods may affect device reliability.
- (2) The input and output negative-voltage ratings may be exceeded if the input and output clamp-current ratings are observed.
- (3) The current flows only when the output is in the high state and $V_O > V_{CC}$.
- (4) The package thermal impedance is calculated in accordance with JESD 51-7.

Recommended Operating Conditions⁽¹⁾⁽²⁾⁽³⁾⁽⁴⁾

		MIN	NOM	MAX	UNIT	
BIAS V_{CC}	Supply voltage	3	3.3	3.6	V	
V_{TT}	Termination voltage	GTL	1.14	1.2	1.26	V
		GTL+	1.35	1.5	1.65	
V_{REF}	Reference voltage	GTL	0.74	0.8	0.87	V
		GTL+	0.87	1	1.1	
V_I	Input voltage	B port	0	V_{TT}	V	
		Except B port	0	V_{CC}		
V_{IH}	High-level input voltage	B port	$V_{REF} + 50$ mV		V	
		V_{ERC}	$V_{CC} - 0.6$	V_{CC}		
		Except B port and ERC	2			
V_{IL}	Low-level input voltage	B port	$V_{REF} - 50$ mV		V	
		V_{ERC}	GND	0.6		
		Except B port and ERC	0.8			
I_{IK}	Input clamp current			–18	mA	
I_{OH}	High-level output current	A port		–24	mA	
I_{OL}	Low-level output current	A port		24	mA	
		B port		100		
$\Delta t/\Delta V_{CC}$	Power-up ramp rate	200			µs/V	
T_A	Operating free-air temperature	–40		85	°C	

- (1) All unused inputs of the device must be held at V_{CC} or GND to ensure proper device operation. Refer to the TI application report, *Implications of Slow or Floating CMOS Inputs*, literature number SCBA004.
- (2) Normal connection sequence is GND first, BIAS $V_{CC} = 3.3$ V second, and $V_{CC} = 3.3$ V, I/O, control inputs, V_{TT} and V_{REF} (any order) last. However, if the B-port I/O precharge is not required, the acceptable connection sequence is GND first and $V_{CC} = 3.3$ V, BIAS $V_{CC} = 3.3$ V, I/O, control inputs, V_{TT} and V_{REF} (any order) last. When V_{CC} is connected, the BIAS V_{CC} circuitry is disabled.
- (3) V_{TT} and R_{TT} can be adjusted to accommodate backplane impedances if the dc recommended I_{OL} ratings are not exceeded.
- (4) V_{REF} can be adjusted to optimize noise margins, but normally is two-thirds V_{TT} .

Electrical Characteristics

 over recommended operating free-air temperature range, $V_{REF} = 1\text{ V}$ and $V_{TT} = 1.5\text{ V}$ (unless otherwise noted)

PARAMETER		TEST CONDITIONS		MIN	TYP ⁽¹⁾	MAX	UNIT	
V_{IK}		$V_{CC} = 3\text{ V}$,	$I_I = -18\text{ mA}$			-1.2	V	
V_{OH}	A port	$V_{CC} = 3\text{ V to } 3.6\text{ V}$,	$I_{OH} = -100\text{ }\mu\text{A}$	$V_{CC} - 0.2$			V	
		$V_{CC} = 3\text{ V}$	$I_{OH} = -12\text{ mA}$	2.4				
			$I_{OH} = -24\text{ mA}$	2.2				
V_{OL}	A port	$V_{CC} = 3\text{ V to } 3.6\text{ V}$,	$I_{OL} = 100\text{ }\mu\text{A}$			0.2	V	
		$V_{CC} = 3\text{ V}$	$I_{OL} = 12\text{ mA}$			0.4		
			$I_{OL} = 24\text{ mA}$			0.55		
	B port	$V_{CC} = 3\text{ V}$	$I_{OL} = 40\text{ mA}$			0.2		
			$I_{OL} = 80\text{ mA}$			0.4		
			$I_{OL} = 100\text{ mA}$			0.5		
I_I	Control inputs	$V_{CC} = 3.6\text{ V}$	$V_I = V_{CC}$ or GND			± 10	μA	
	B port		$V_I = V_{TT}$ or GND			± 10		
I_{off}		$V_{CC} = 0$,	V_I or $V_O = 0$ to 3.6 V			± 100	μA	
$I_{I(hold)}$	A port	$V_{CC} = 3\text{ V}$	$V_I = 0.8\text{ V}$	75			μA	
			$V_I = 2\text{ V}$	-75				
		$V_{CC} = 3.6\text{ V}^{(2)}$,	$V_I = 0$ to V_{CC}			± 500		
I_{OZH}	B port	$V_{CC} = 3.6\text{ V}$,	$V_O = 1.5\text{ V}$			10	μA	
I_{OZL}	B port	$V_{CC} = 3.6\text{ V}$,	$V_O = 0.4\text{ V}$			-10	μA	
$I_{OZ}^{(3)}$	A port	$V_{CC} = 3.6\text{ V}$,	$V_O = V_{CC}$ or GND			± 10	μA	
I_{OZPU}	A port	$V_{CC} = 0$ to 3.6 V , $V_O = 0.5\text{ V}$ to 3 V , $\overline{OE} = \text{low}$				± 50	μA	
I_{OZPD}	A port	$V_{CC} = 3.6\text{ V}$ to 0 , $V_O = 0.5\text{ V}$ to 3 V , $\overline{OE} = \text{low}$				± 50	μA	
I_{CC}	A or B port	$V_{CC} = 3.6\text{ V}$, $I_O = 0$, $V_I = V_{CC}$ or GND	Outputs high			80	mA	
			Outputs low			80		
			Outputs disabled			80		
$\Delta I_{CC}^{(4)}$	Except B port	$V_{CC} = 3.6\text{ V}$, A-port or control inputs at V_{CC} or GND, One input at $V_{CC} - 0.6\text{ V}$				1	mA	
C_i	Control inputs	$V_I = V_{CC}$ or 0				3	5	pF
C_{io}	A port	$V_O = V_{CC}$ or 0				5	6	pF
	B port					6	8	

 (1) All typical values are at $V_{CC} = 3.3\text{ V}$, $T_A = 25^\circ\text{C}$.

(2) This is the bus-hold maximum dynamic current. It is the minimum overdrive current required to switch the input from one state to another.

 (3) For I/O ports, the parameter I_{OZ} includes the input leakage current.

 (4) This is the increase in supply current for each input that is at the specified TTL voltage level rather than V_{CC} or GND.

Live-Insertion Specifications

over recommended operating free-air temperature range

PARAMETER		TEST CONDITIONS		MIN	MAX	UNIT
I_{CC} (BIAS V_{CC})	$V_{CC} = 0$ to 3 V	V_O (B port) = 0 to 1.2 V ,	V_I (BIAS V_{CC}) = 3 V to 3.6 V		5	mA
	$V_{CC} = 3\text{ V}$ to 3.6 V				10	μA
V_O	B port	$V_{CC} = 0$,	V_I (BIAS V_{CC}) = 3.3 V	1	1.2	V
I_O	B port	$V_{CC} = 0$,	V_O (B port) = 0.4 V ,	V_I (BIAS V_{CC}) = 3 V to 3.6 V	-1	μA
		$V_{CC} = 0$ to 3.6 V ,	$\overline{OE} = 3.3\text{ V}$		100	
		$V_{CC} = 0$ to 1.5 V ,	$\overline{OE} = 0$ to 3.3 V		100	

SN74GTL1655

16-BIT LVTTTL-TO-GTL/GTL+ UNIVERSAL BUS TRANSCEIVER WITH LIVE INSERTION

SCBS696I—JULY 1997—REVISED APRIL 2005

Timing Requirements

over recommended ranges of supply voltage and operating free-air temperature,
 $V_{TT} = 1.2\text{ V}$, $V_{REF} = 0.8\text{ V}$, and $V_{ERC} = V_{CC}$ or GND for GTL (unless otherwise noted)

			MIN	MAX	UNIT
f_{clock}	Clock frequency			160	MHz
t_w	Pulse duration	LE high		3	ns
		CLK high or low		3	
t_{su}	Setup time	Data before CLK \uparrow		2.7	ns
		Data before LE \downarrow	CLK high	2.8	
			CLK low	2.6	
t_h	Hold time	Data after CLK \uparrow		0.4	ns
		Data after LE \downarrow	CLK high or low	0.9	

A-to-B Switching Characteristics

over recommended ranges of supply voltage and operating free-air temperature,
 $V_{TT} = 1.2\text{ V}$, $V_{REF} = 0.8\text{ V}$, and $V_{ERC} = V_{CC}$ or GND for GTL (see Figure 1)

PARAMETER	FROM (INPUT)	TO (OUTPUT)	MIN	TYP	MAX	UNIT
f_{max}			160			MHz
t_{PLH}	A	B	3.1		5.2	ns
t_{PHL}	$V_{\text{ERC}} = V_{\text{CC}}$		2.6		6.2	
t_{PLH}	CLK	B	3.4		5.5	ns
t_{PHL}	$V_{\text{ERC}} = V_{\text{CC}}$		2.4		5.8	
t_{PLH}	LEAB	B	3.5		5.8	ns
t_{PHL}	$V_{\text{ERC}} = V_{\text{CC}}$		2.6		6.4	
t_{en}	$\overline{\text{OEAB}}$ or $\overline{\text{OE}}$	B	3.3		5.4	ns
t_{dis}	$V_{\text{ERC}} = V_{\text{CC}}$		2.7		5.9	
t_{PLH}	A	B	2.3		4.3	ns
t_{PHL}	$V_{\text{ERC}} = \text{GND}$		1.9		4.3	
t_{PLH}	CLK	B	2.7		4.8	ns
t_{PHL}	$V_{\text{ERC}} = \text{GND}$		1.8		4.3	
t_{PLH}	LEAB	B	2.8		4.9	ns
t_{PHL}	$V_{\text{ERC}} = \text{GND}$		2		4.8	
t_{en}	$\overline{\text{OEAB}}$ or $\overline{\text{OE}}$	B	2.5		4.5	ns
t_{dis}	$V_{\text{ERC}} = \text{GND}$		2		4.2	
t_r	$V_{\text{ERC}} = \text{GND}$	Transition time, B outputs (0.6 V to 1 V)		0.6		ns
	$V_{\text{ERC}} = V_{\text{CC}}$			1.2		
t_f	$V_{\text{ERC}} = \text{GND}$	Transition time, B outputs (1 V to 0.6 V)		1.1		ns
	$V_{\text{ERC}} = V_{\text{CC}}$			1.7		
$t_{\text{sk(o)}}^{(1)}$		Skew between drivers in the same package switching in the same direction			1	ns
$t_{\text{sk(o)}}^{(2)}$		Skew between drivers switching in any direction in the same package			1	ns

- (1) Skew values are applicable for through mode only.
(2) Skew values are applicable for CLK mode only, with all outputs switching simultaneously.

B-to-A Switching Characteristics

over recommended ranges of supply voltage and operating free-air temperature,
 $V_{TT} = 1.2\text{ V}$ and $V_{REF} = 0.8\text{ V}$ for GTL (see Figure 1)

PARAMETER	FROM (INPUT)	TO (OUTPUT)	MIN	MAX	UNIT
f_{max}			160		MHz
t_{PLH}	B	A	1.8	4.7	ns
t_{PHL}			2.3	4.6	
t_{PLH}	CLK	A	1.6	4	ns
t_{PHL}			1.5	3.4	
t_{PLH}	LEBA	A	1.7	4	ns
t_{PHL}			1.4	3.5	
t_{en}	\overline{OEBA} or \overline{OE}	A	1.2	4.2	ns
t_{dis}			1.2	6.1	
$t_{sk(o)}^{(1)}$	Skew between drivers in the same package switching in the same direction			1	ns
$t_{sk(o)}^{(2)}$	Skew between drivers switching in any direction in the same package			1	ns

(1) Skew values are applicable for through mode only.

(2) Skew values are applicable for CLK mode only, with all outputs switching simultaneously.

SN74GTL1655

16-BIT LVTTTL-TO-GTL/GTL+ UNIVERSAL BUS TRANSCEIVER WITH LIVE INSERTION

SCBS696I–JULY 1997–REVISED APRIL 2005

Timing Requirements

over recommended ranges of supply voltage and operating free-air temperature,
 $V_{TT} = 1.5\text{ V}$, $V_{REF} = 1\text{ V}$, and $V_{ERC} = V_{CC}$ or GND for GTL+ (unless otherwise noted)

			MIN	MAX	UNIT
f_{clock}	Clock frequency			160	MHz
t_w	Pulse duration	LE high		3	ns
		CLK high or low		3	
t_{su}	Setup time	Data before CLK \uparrow		2.7	ns
		Data before LE \downarrow	CLK high	2.8	
			CLK low	2.6	
t_h	Hold time	Data after CLK \uparrow		0.4	ns
		Data after LE \downarrow	CLK high or low	0.9	

A-to-B Switching Characteristics

over recommended ranges of supply voltage and operating free-air temperature,
 $V_{TT} = 1.5\text{ V}$, $V_{REF} = 1\text{ V}$, and $V_{ERC} = V_{CC}$ or GND for GTL+ (see Figure 1)

PARAMETER	FROM (INPUT)	TO (OUTPUT)	MIN	TYP	MAX	UNIT
f_{max}			160			MHz
t_{PLH}	A $V_{ERC} = V_{CC}$	B	3		5.1	ns
t_{PHL}			2.9	6.5		
t_{PLH}	CLK $V_{ERC} = V_{CC}$	B	3.4		5.4	ns
t_{PHL}			2.7	6.2		
t_{PLH}	LEAB $V_{ERC} = V_{CC}$	B	3.5		5.7	ns
t_{PHL}			2.8	6.7		
t_{en}	$\overline{\text{OEAB}}$ $V_{ERC} = V_{CC}$	B	3.3		5.4	ns
t_{dis}			3	6.3		
t_{en}	$\overline{\text{OE}}$ $V_{ERC} = V_{CC}$	B	3		5.5	ns
t_{dis}			3.6	5.8		
t_{PLH}	A $V_{ERC} = \text{GND}$	B	2.3		4.3	ns
t_{PHL}			2	4.4		
t_{PLH}	CLK $V_{ERC} = \text{GND}$	B	2.7		4.8	ns
t_{PHL}			1.9	4.5		
t_{PLH}	LEAB $V_{ERC} = \text{GND}$	B	2.8		4.9	ns
t_{PHL}			2.1	4.9		
t_{en}	$\overline{\text{OEAB}}$ $V_{ERC} = \text{GND}$	B	2.5		4.5	ns
t_{dis}			2.1	4.4		
t_{en}	$\overline{\text{OE}}$ $V_{ERC} = \text{GND}$	B	2.5		4.6	ns
t_{dis}			2.9	4.9		
t_r	$V_{ERC} = \text{GND}$	Transition time, B outputs (0.6 V to 1.3 V)	0.9		ns	
	$V_{ERC} = V_{CC}$		1.7			
t_f	$V_{ERC} = \text{GND}$	Transition time, B outputs (1.3 V to 0.6 V)	1.6		ns	
	$V_{ERC} = V_{CC}$		2.4			
$t_{\text{sk(o)}}^{(1)}$	Skew between drivers in the same package switching in the same direction			1	ns	
$t_{\text{sk(o)}}^{(2)}$	Skew between drivers switching in any direction in the same package			1	ns	

(1) Skew values are applicable for through mode only.

(2) Skew values are applicable for CLK mode only, with all outputs switching simultaneously.

B-to-A Switching Characteristics

over recommended ranges of supply voltage and operating free-air temperature,
 $V_{TT} = 1.5\text{ V}$ and $V_{REF} = 1\text{ V}$ for GTL+ (see Figure 1)

PARAMETER	FROM (INPUT)	TO (OUTPUT)	MIN	MAX	UNIT
f_{max}			160		MHz
t_{PLH}	B	A	2	4.8	ns
t_{PHL}			2.4	4.7	
t_{PLH}	CLK	A	1.6	4.4	ns
t_{PHL}			1.5	3.4	
t_{PLH}	LEBA	A	1.7	4	ns
t_{PHL}			1.4	3.5	
t_{en}	\overline{OEBA}	A	1.2	4.2	ns
t_{dis}			1.2	6.1	
t_{en}	\overline{OE}	A	1.2	4.7	ns
t_{dis}			1.2	6.3	
$t_{sk(o)}^{(1)}$	Skew between drivers in the same package switching in the same direction			1	ns
$t_{sk(o)}^{(2)}$	Skew between drivers switching in any direction in the same package			1	ns

(1) Skew values are applicable for through mode only.

(2) Skew values are applicable for CLK mode only, with all outputs switching simultaneously.

PARAMETER MEASUREMENT INFORMATION

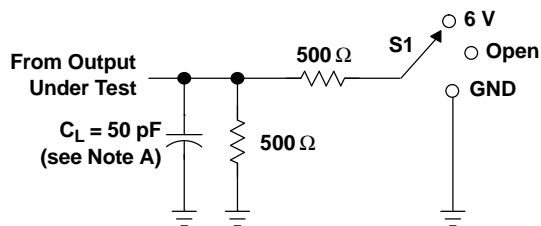

LOAD CIRCUIT FOR A OUTPUTS

TEST	S1
t_{PLH}/t_{PHL}	Open
t_{PLZ}/t_{PZL}	6 V
t_{PHZ}/t_{PZH}	GND

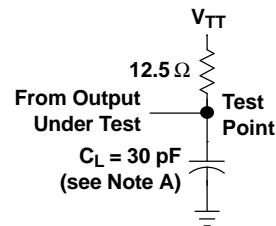

LOAD CIRCUIT FOR B OUTPUTS

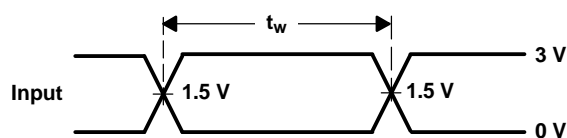

VOLTAGE WAVEFORMS
 PULSE DURATION

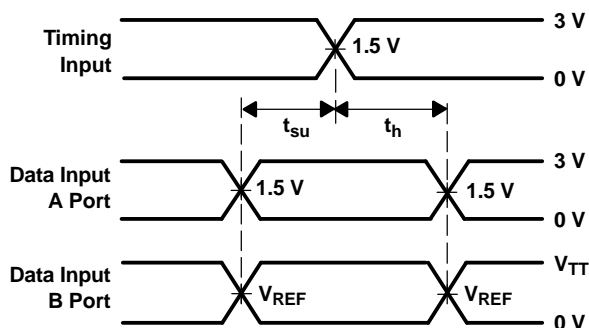

VOLTAGE WAVEFORMS
 SETUP AND HOLD TIMES

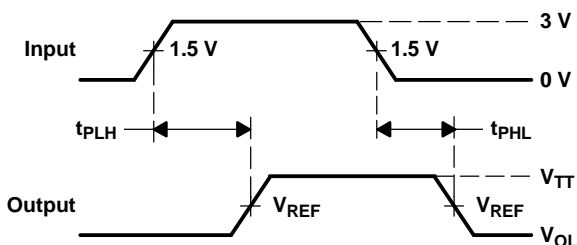

VOLTAGE WAVEFORMS
 PROPAGATION DELAY TIMES
 (CLK to B port)

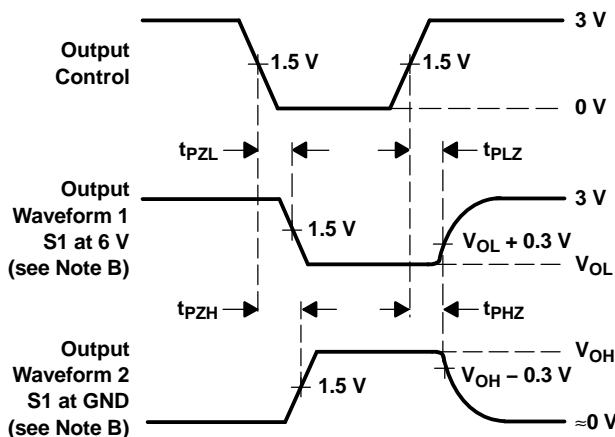

VOLTAGE WAVEFORMS
 ENABLE AND DISABLE TIMES
 (A port)

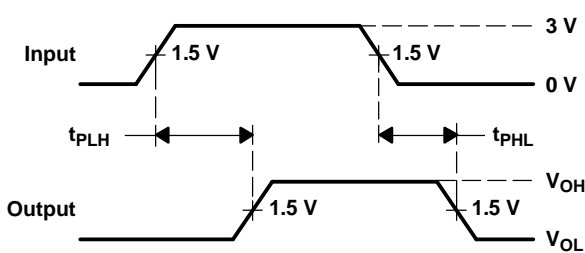

VOLTAGE WAVEFORMS
 PROPAGATION DELAY TIMES
 (CLK to A port)

- NOTES: A. C_L includes probe and jig capacitance.
 B. Waveform 1 is for an output with internal conditions such that the output is low, except when disabled by the output control. Waveform 2 is for an output with internal conditions such that the output is high, except when disabled by the output control.
 C. All input pulses are supplied by generators having the following characteristics: $PRR \leq 10$ MHz, $Z_O = 50 \Omega$, $t_r \leq 2.5$ ns, $t_f \leq 2.5$ ns.
 D. The outputs are measured one at a time, with one transition per measurement.
 E. t_{PLZ} and t_{PHZ} are the same as t_{dis} .
 F. t_{PZL} and t_{PZH} are the same as t_{en} .

Figure 1. Load Circuits and Voltage Waveforms

PACKAGING INFORMATION

Orderable Device	Status (1)	Package Type	Package Drawing	Pins	Package Qty	Eco Plan (2)	Lead finish/ Ball material (6)	MSL Peak Temp (3)	Op Temp (°C)	Device Marking (4/5)	Samples
SN74GTL1655DGGR	ACTIVE	TSSOP	DGG	64	2000	RoHS & Green	NIPDAU	Level-1-260C-UNLIM	-40 to 85	GTL1655	Samples

(1) The marketing status values are defined as follows:

ACTIVE: Product device recommended for new designs.

LIFEBUY: TI has announced that the device will be discontinued, and a lifetime-buy period is in effect.

NRND: Not recommended for new designs. Device is in production to support existing customers, but TI does not recommend using this part in a new design.

PREVIEW: Device has been announced but is not in production. Samples may or may not be available.

OBSOLETE: TI has discontinued the production of the device.

(2) **RoHS:** TI defines "RoHS" to mean semiconductor products that are compliant with the current EU RoHS requirements for all 10 RoHS substances, including the requirement that RoHS substance do not exceed 0.1% by weight in homogeneous materials. Where designed to be soldered at high temperatures, "RoHS" products are suitable for use in specified lead-free processes. TI may reference these types of products as "Pb-Free".

RoHS Exempt: TI defines "RoHS Exempt" to mean products that contain lead but are compliant with EU RoHS pursuant to a specific EU RoHS exemption.

Green: TI defines "Green" to mean the content of Chlorine (Cl) and Bromine (Br) based flame retardants meet JS709B low halogen requirements of <=1000ppm threshold. Antimony trioxide based flame retardants must also meet the <=1000ppm threshold requirement.

(3) MSL, Peak Temp. - The Moisture Sensitivity Level rating according to the JEDEC industry standard classifications, and peak solder temperature.

(4) There may be additional marking, which relates to the logo, the lot trace code information, or the environmental category on the device.

(5) Multiple Device Markings will be inside parentheses. Only one Device Marking contained in parentheses and separated by a "-" will appear on a device. If a line is indented then it is a continuation of the previous line and the two combined represent the entire Device Marking for that device.

(6) Lead finish/Ball material - Orderable Devices may have multiple material finish options. Finish options are separated by a vertical ruled line. Lead finish/Ball material values may wrap to two lines if the finish value exceeds the maximum column width.

Important Information and Disclaimer:The information provided on this page represents TI's knowledge and belief as of the date that it is provided. TI bases its knowledge and belief on information provided by third parties, and makes no representation or warranty as to the accuracy of such information. Efforts are underway to better integrate information from third parties. TI has taken and continues to take reasonable steps to provide representative and accurate information but may not have conducted destructive testing or chemical analysis on incoming materials and chemicals. TI and TI suppliers consider certain information to be proprietary, and thus CAS numbers and other limited information may not be available for release.

In no event shall TI's liability arising out of such information exceed the total purchase price of the TI part(s) at issue in this document sold by TI to Customer on an annual basis.

TAPE AND REEL INFORMATION
REEL DIMENSIONS

TAPE DIMENSIONS

A0	Dimension designed to accommodate the component width
B0	Dimension designed to accommodate the component length
K0	Dimension designed to accommodate the component thickness
W	Overall width of the carrier tape
P1	Pitch between successive cavity centers

TAPE AND REEL INFORMATION

*All dimensions are nominal

Device	Package Type	Package Drawing	Pins	SPQ	Reel Diameter (mm)	Reel Width W1 (mm)	A0 (mm)	B0 (mm)	K0 (mm)	P1 (mm)	W (mm)	Pin1 Quadrant
SN74GTL1655DGGR	TSSOP	DGG	64	2000	330.0	24.4	8.4	17.3	1.7	12.0	24.0	Q1

TAPE AND REEL BOX DIMENSIONS



*All dimensions are nominal

Device	Package Type	Package Drawing	Pins	SPQ	Length (mm)	Width (mm)	Height (mm)
SN74GTL1655DGGR	TSSOP	DGG	64	2000	367.0	367.0	45.0

DGG (R-PDSO-G**)

PLASTIC SMALL-OUTLINE PACKAGE

48 PINS SHOWN



- NOTES: A. All linear dimensions are in millimeters.
 B. This drawing is subject to change without notice.
 C. Body dimensions do not include mold protrusion not to exceed 0,15.
 D. Falls within JEDEC MO-153

IMPORTANT NOTICE AND DISCLAIMER

TI PROVIDES TECHNICAL AND RELIABILITY DATA (INCLUDING DATASHEETS), DESIGN RESOURCES (INCLUDING REFERENCE DESIGNS), APPLICATION OR OTHER DESIGN ADVICE, WEB TOOLS, SAFETY INFORMATION, AND OTHER RESOURCES "AS IS" AND WITH ALL FAULTS, AND DISCLAIMS ALL WARRANTIES, EXPRESS AND IMPLIED, INCLUDING WITHOUT LIMITATION ANY IMPLIED WARRANTIES OF MERCHANTABILITY, FITNESS FOR A PARTICULAR PURPOSE OR NON-INFRINGEMENT OF THIRD PARTY INTELLECTUAL PROPERTY RIGHTS.

These resources are intended for skilled developers designing with TI products. You are solely responsible for (1) selecting the appropriate TI products for your application, (2) designing, validating and testing your application, and (3) ensuring your application meets applicable standards, and any other safety, security, or other requirements. These resources are subject to change without notice. TI grants you permission to use these resources only for development of an application that uses the TI products described in the resource. Other reproduction and display of these resources is prohibited. No license is granted to any other TI intellectual property right or to any third party intellectual property right. TI disclaims responsibility for, and you will fully indemnify TI and its representatives against, any claims, damages, costs, losses, and liabilities arising out of your use of these resources.

TI's products are provided subject to TI's Terms of Sale (www.ti.com/legal/termsofsale.html) or other applicable terms available either on ti.com or provided in conjunction with such TI products. TI's provision of these resources does not expand or otherwise alter TI's applicable warranties or warranty disclaimers for TI products.

Mailing Address: Texas Instruments, Post Office Box 655303, Dallas, Texas 75265
Copyright © 2020, Texas Instruments Incorporated







Looking for pricing, stock, or lifecycle information?

Click below to explore more details on WIN SOURCE:

 [View SN74GTL1655DGGR on WIN SOURCE](#)

 [Texas Instruments](#) Information

Optimize Your Supply Chain with WIN SOURCE Solutions

-  Global Sourcing Solution
-  Obsolete Management
-  Cost Control Management
-  Shortage Management
-  Alternative Solution
-  Excess Inventory Management