



**THE DATASHEET OF
SN74CBTLV3383PWR**



SN74CBTLV3383 Low-Voltage 10-Bit FET Bus-Exchange Switch

1 Features

- 5- Ω Switch Connection Between Two Ports
- Rail-to-Rail Switching on Data I/O Ports
- I_{off} Supports Partial-Power-Down Mode Operation
- Latch-Up Performance Exceeds 250 mA Per JESD 17
- ESD Protection Exceeds JESD 22
 - 2000-V Human-Body Model (A114-A)
 - 200-V Machine Model (A115-A)

2 Applications

- Gaming
- Rack Server
- Communication Board

3 Description

The SN74CBTLV3383 provides ten bits of high-speed bus switching or exchanging. The low on-state resistance of the switch allows connections to be made with minimal propagation delay.

The device operates as a 10-bit bus switch or as a 5-bit bus exchanger, which provides swapping of the A and B pairs of signals. The bus-exchange function is selected when BX is high, and \overline{BE} is low.

This device is fully specified for partial-power-down applications using I_{off} . The I_{off} feature ensures that damaging current will not backflow through the device when it is powered down. The device has isolation during power off.

Device Information⁽¹⁾

PART NUMBER	PACKAGE	BODY SIZE (NOM)
SN74CBTLV3383	QSOP – DBQ	8.65 mm x 3.90 mm
	SOIC – DW	15.4 mm x 7.50 mm
	TSSOP – PW	7.80 mm x 4.40 mm
	TVSOP – DGV	5.00 mm x 4.40 mm

(1) For all available packages, see the orderable addendum at the end of the data sheet.

Simplified Schematic, Each FET Switch

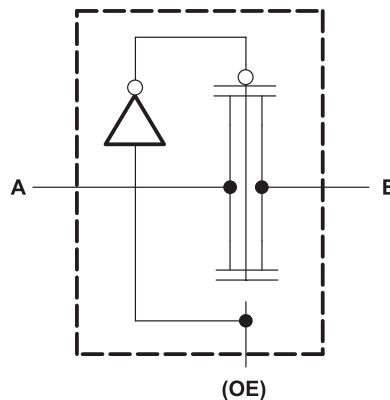

Table of Contents

1 Features 1 2 Applications 1 3 Description 1 4 Revision History 2 5 Pin Configuration and Functions 3 6 Specifications 4 6.1 Absolute Maximum Ratings 4 6.2 ESD Ratings..... 4 6.3 Recommended Operating Conditions..... 4 6.4 Thermal Information 4 6.5 Electrical Characteristics..... 5 6.6 Switching Characteristics 5 7 Parameter Measurement Information 6 8 Detailed Description 7 8.1 Overview 7 8.2 Functional Block Diagram 7 8.3 Feature Description..... 7	8.4 Device Functional Modes..... 8 9 Application and Implementation 9 9.1 Application Information..... 9 9.2 Typical Application 9 10 Power Supply Recommendations 10 11 Layout 11 11.1 Layout Guidelines 11 11.2 Layout Example 11 12 Device and Documentation Support 12 12.1 Documentation Support 12 12.2 Receiving Notification of Documentation Updates 12 12.3 Community Resources..... 12 12.4 Trademarks 12 12.5 Electrostatic Discharge Caution..... 12 12.6 Glossary 12 13 Mechanical, Packaging, and Orderable Information 12
---	---

4 Revision History

NOTE: Page numbers for previous revisions may differ from page numbers in the current version.

Changes from Revision G (October 2003) to Revision H	Page
<ul style="list-style-type: none"> • Added <i>Device Information</i> table, <i>ESD Ratings</i> table, <i>Feature Description</i> section, <i>Device Functional Modes</i>, <i>Application and Implementation</i> section, <i>Power Supply Recommendations</i> section, <i>Layout</i> section, <i>Device and Documentation Support</i> section, and <i>Mechanical, Packaging, and Orderable Information</i> section. 	1

5 Pin Configuration and Functions

DBQ, DGV, DW, OR PW Package
24-Pin
Top View

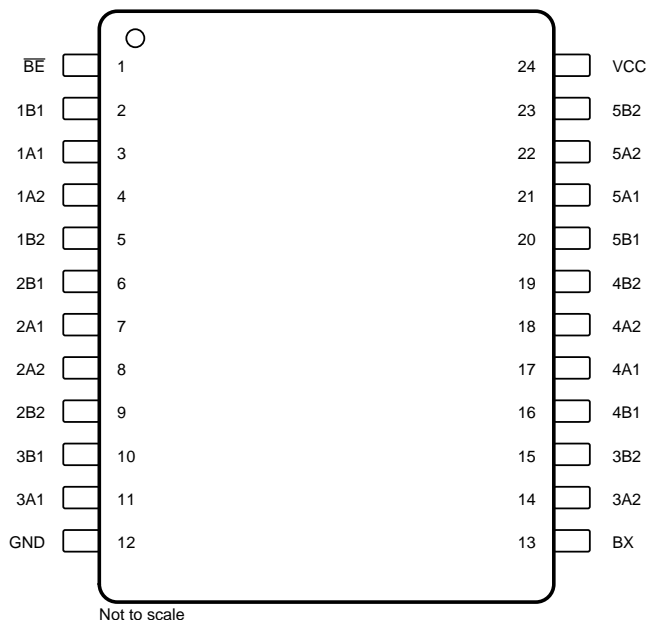

Pin Functions

PIN		I/O	DESCRIPTION
NAME	NO.		
\overline{BE}	1	I	Active low enable: When this pin is high, all switches are turned off. When this pin is low, BX pin controls the signal path selection.
1B1	2	I/O	Signal path. Can be an input or output
1A1	3	I/O	Signal path. Can be an input or output
1A2	4	I/O	Signal path. Can be an input or output
1B2	5	I/O	Signal path. Can be an input or output
2B1	6	I/O	Signal path. Can be an input or output
2A1	7	I/O	Signal path. Can be an input or output
2A2	8	I/O	Signal path. Can be an input or output
2B2	9	I/O	Signal path. Can be an input or output
3B1	10	I/O	Signal path. Can be an input or output
3A1	11	I/O	Signal path. Can be an input or output
GND	12	P	Ground (0V) reference
BX	13	I	Controls state of switches
3A2	14	I/O	Signal path. Can be an input or output
3B2	15	I/O	Signal path. Can be an input or output
4B1	16	I/O	Signal path. Can be an input or output
4A1	17	I/O	Signal path. Can be an input or output
4A2	18	I/O	Signal path. Can be an input or output
4B2	19	I/O	Signal path. Can be an input or output
5B1	20	I/O	Signal path. Can be an input or output
5A1	21	I/O	Signal path. Can be an input or output
5A2	22	I/O	Signal path. Can be an input or output
5B2	23	I/O	Signal path. Can be an input or output
V _{CC}	24	P	Positive power supply.

6 Specifications

6.1 Absolute Maximum Ratings

over operating free-air temperature range (unless otherwise noted)⁽¹⁾

		MIN	MAX	UNIT
V_{CC}	Supply voltage range	-0.5	4.6	V
V_I	Input voltage range	-0.5	4.6	V
	Continuous channel current		128	mA
I_{IK}	Input clamp current, $V_{IO} < 0$		-50	mA
T_{stg}	Storage temperature	-65	150	°C

(1) Stresses beyond those listed under *Absolute Maximum Ratings* may cause permanent damage to the device. These are stress ratings only, which do not imply functional operation of the device at these or any other conditions beyond those indicated under *Recommended Operating Conditions*. Exposure to absolute-maximum-rated conditions for extended periods may affect device reliability.

6.2 ESD Ratings

			VALUE	UNIT
$V_{(ESD)}$	Electrostatic discharge	Human-body model (HBM), per ANSI/ESDA/JEDEC JS-001 ⁽¹⁾	±2000	V
		Charged-device model (CDM), per JEDEC specification JESD22-C101 ⁽²⁾	±1000	

(1) JEDEC document JEP155 states that 500-V HBM allows safe manufacturing with a standard ESD control process.

(2) JEDEC document JEP157 states that 250-V CDM allows safe manufacturing with a standard ESD control process.

6.3 Recommended Operating Conditions⁽¹⁾

over operating free-air temperature range (unless otherwise noted)

			MIN	NOM	MAX	UNIT
V_{CC}	Supply voltage		2.3		3.6	V
V_{IH}	High-level control input voltage	$V_{CC} = 2.3\text{ V to }2.7\text{ V}$	1.7			V
		$V_{CC} = 2.7\text{ V to }3.6\text{ V}$	2			V
V_{IL}	Low-level control input voltage	$V_{CC} = 2.3\text{ V to }2.7\text{ V}$			0.7	V
		$V_{CC} = 2.7\text{ V to }3.6\text{ V}$			0.8	V
T_A	Operating free-air temperature		-40		85	°C

(1) All unused control inputs of the device must be held at V_{CC} or GND to ensure proper device operation. Refer to the TI application report, [Implications of Slow or Floating CMOS Inputs](#).

6.4 Thermal Information

THERMAL METRIC ⁽¹⁾		SN74CBTLV3383				UNIT
		DBQ (QSOP)	DVG (TVSOP)	DW (SPIC)	PW (TSSOP)	
		24 PINS	24 PINS	24 PINS	24 PINS	
$R_{\theta JA}$	Junction-to-ambient thermal resistance	86.6	105.6	66.6	90.1	°C/W
$R_{\theta JC(top)}$	Junction-to-case (top) thermal resistance	40.5	36.9	36.7	34.12	°C/W
$R_{\theta JB}$	Junction-to-board thermal resistance	40.8	51.1	36.6	45.2	°C/W
ψ_{JT}	Junction-to-top characterization parameter	7.8	2.6	13.1	2.8	°C/W
ψ_{JB}	Junction-to-board characterization parameter	40.4	50.6	36.4	44.8	°C/W
$R_{\theta JC(bot)}$	Junction-to-case (bottom) thermal resistance	n/a	n/a	n/a	n/a	°C/W

(1) For more information about traditional and new thermal metrics, see the [Semiconductor and IC Package Thermal Metrics](#) application report.

6.5 Electrical Characteristics

over operating free-air temperature range (unless otherwise noted)

PARAMETER		TEST CONDITIONS		MIN	TYP ⁽¹⁾	MAX	UNIT
V_{IK}	Clamp current	$V_{CC} = 3\text{ V}$	$I_I = -18\text{ mA}$			-1.2	V
I_I	Input current	$V_{CC} = 3.6\text{ V}$	$V_I = V_{CC}$ or GND	-1		1	μA
I_{off}	Partial power down mode operation	$V_{CC} = 0\text{ V}$	V_I or $V_{IO} = 0$ to 3.6 V			10	μA
I_{CC}	Supply current	$V_{CC} = 3.6$	$I_O = 0$, $V_I = V_{CC}$ or GND			10	μA
$\Delta I_{CC}^{(2)}$	Supply current - Control inputs	$V_{CC} = 3.6\text{ V}$	One input at 3V			300	μA
C_I	Input Capacitance - Control inputs	$V_I = 3\text{ V}$ or 0			3.5		pF
$C_{IO(OFF)}$	Input to output capacitance	$V_O = 3\text{ V}$ or 0	$\overline{BE} = V_{CC}$		13.5		pF
$r_{(on)}^{(3)}$	On-state resistance	$V_{CC} = 2.3\text{ V}$ TYP at $V_{CC} = 2.5\text{ V}$	$V_I = 0$	$I_I = 64\text{ mA}$	5	8	Ω
				$I_I = 24\text{ mA}$	5	8	Ω
			$V_I = 1.7\text{ V}$	$I_I = 15\text{ mA}$	27	40	Ω
		$V_{CC} = 3\text{ V}$	$V_I = 0$	$I_I = 64\text{ mA}$	5	7	Ω
				$I_I = 24\text{ mA}$	5	7	Ω
			$V_I = 2.4\text{ V}$	$I_I = 15\text{ mA}$	10	15	Ω

 (1) All typical values are at $V_{CC} = 3.3\text{ V}$ (unless otherwise noted), $T_A = 25^\circ\text{C}$

 (2) This is the increase in supply current for each input that is at the specified voltage level, rather than V_{CC} or GND.

(3) Measured by the voltage drop between the A and B terminals at the indicated current through the switch. On-state resistance is determined by the lower of the voltages of the two (A or B) terminals.

6.6 Switching Characteristics

over operating free-air temperature range (unless otherwise noted)

PARAMETER	TEST CONDITIONS	$V_{CC} = 2.5\text{ V} \pm 0.2\text{ V}$		$V_{CC} = 3.3\text{ V} \pm 0.3\text{ V}$		UNIT		
		FROM (INPUT)	TO (OUTPUT)	MIN	MAX		MIN	MAX
$t_{pd}^{(1)}$	Propagation delay time	A or B	Bo or A	0.15		0.25	ns	
t_{pd}	Propagation delay time	BX	A or B	1.5	5.8	1.5	4.7	ns
t_{en}	Enable time	\overline{BE}	A or B	1.5	5.3	1.5	4.7	ns
t_{dis}	Disable time	\overline{BE}	A or B	1	6	1	6	ns

(1) The propagation delay is the calculated RC time constant of the typical on-state resistance of the switch and the specified load capacitance, when driven by an ideal voltage source (zero output impedance).

7 Parameter Measurement Information

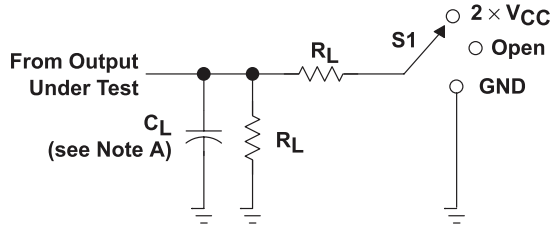

TEST	S1
t_{PLH}/t_{PHL}	Open
t_{PLZ}/t_{PZL}	$2 \times V_{CC}$
t_{PHZ}/t_{PZH}	GND

V_{CC}	C_L	R_L	V_{Δ}
$2.5 \text{ V} \pm 0.2 \text{ V}$	30 pF	500 Ω	0.15 V
$3.3 \text{ V} \pm 0.3 \text{ V}$	50 pF	500 Ω	0.3 V

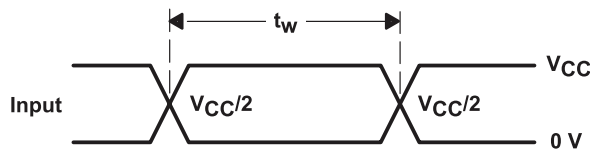
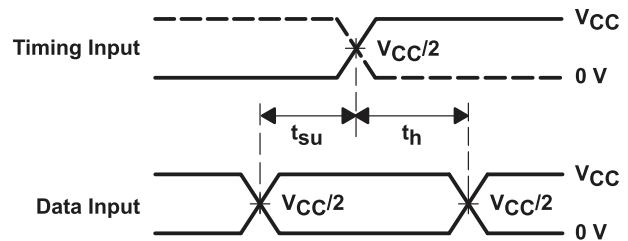
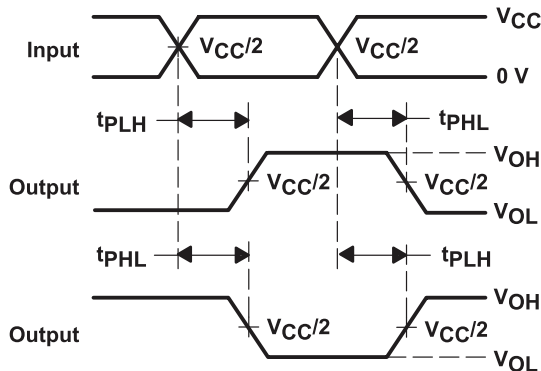
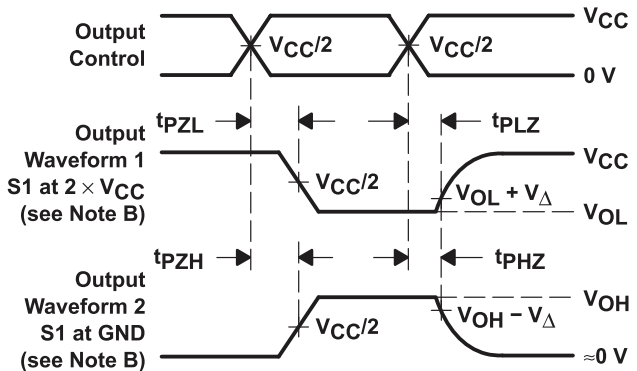
Figure 1. Load Current

Figure 2. Voltage Waveforms Pulse Duration

Figure 3. Voltage Waveforms Setup and Hold Times

Figure 4. Voltage Waveforms Propagation Delay Times Inverting and Noninverting Outputs

Figure 5. Voltage Waveforms Enable And Disable Times Low- and High-Level Enabling
Notes:

- C_L includes probe and jig capacitance.
- Waveform 1 is for an output with internal conditions such that the output is low except when disabled by the output control. Waveform 2 is for an output with internal conditions such that the output is high except when disabled by the output control
- All input pulses are supplied by generators having the following characteristics: $PRR \leq 10 \text{ MHz}$, $Z_O = 50 \Omega$, $t_r \leq 2 \text{ ns}$, $t_f \leq 2 \text{ ns}$.
- The outputs are measured one at a time with one transition per measurement.
- t_{PLZ} and t_{PHZ} are the same as t_{dis} .
- t_{PZL} and t_{PZH} are the same as t_{en} .
- t_{PLH} and t_{PHL} are the same as t_{pd} .
- All parameters and waveforms are not applicable to all devices.

8 Detailed Description

8.1 Overview

The SN74CBTLV3383 device is a 10-bit high-speed bus exchange FET switch. The low ONstate resistance of the switch allows connections to be made with minimal propagation delay. The select (BX) input controls the data flow. The FET multiplexers and demultiplexers are disabled when the output-enable ($\overline{\text{BE}}$) input is high. This device is fully specified for partial-power-down applications using Ioff. The Ioff feature ensures that damaging current will not backflow through the device when it is powered down. The device has isolation during power off. To ensure the high-impedance state during power up or power down, OE should be tied to VCC through a pullup resistor; the minimum value of the resistor is determined by the current-sinking capability of the driver.

8.2 Functional Block Diagram

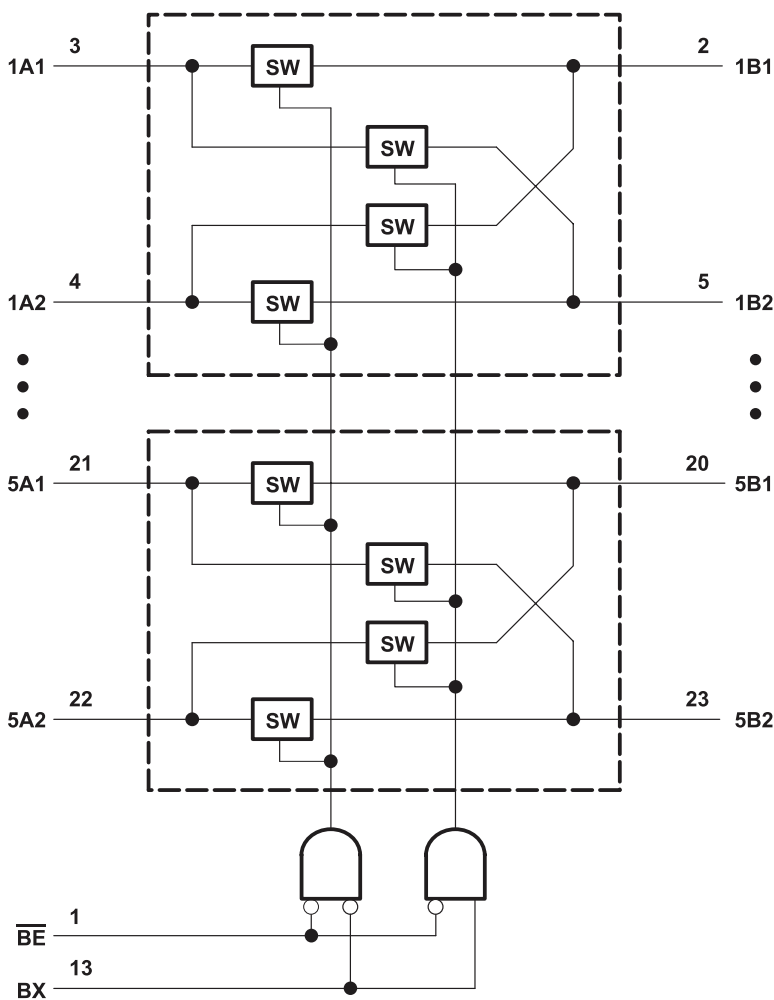

8.3 Feature Description

Bidirectional Operation

The SN74CBTLV3383 conducts equally well from source (xA1, xA2) to drain (xB1, xB2). Each channel has very similar characteristics in both directions and supports both analog and digital signals.

Rail-to-rail switching

The SN74CBTLV3383 will support signals on the I/O path across the full supply range 0 to V_{CC}

8.4 Device Functional Modes

Shows the functional modes of the SN74CBTLV3383.

Table 1. Function Table

INPUTS		INPUTS–OUTPUTS	
$\overline{\text{BE}}$	BX	1A1–5A1	1A2–5A2
L	L	1B1–5B1	1B2–5B2
L	H	1B2–5B2	1B1–5B1
H	X	Z	Z

9 Application and Implementation

NOTE

Information in the following applications sections is not part of the TI component specification, and TI does not warrant its accuracy or completeness. TI's customers are responsible for determining suitability of components for their purposes. Customers should validate and test their design implementation to confirm system functionality.

9.1 Application Information

The SN74CBTLV3383 device operates as a 10-bit bus switch or as a 5-bit bus exchanger, which provides swapping of the A and B pairs of signals. The bus-exchange function is selected when BX is high, and BE is low. The application shown here is a 5-bit bus being multiplexed between two devices. The BE and BX pins are used to control the chip from the bus controller. This is a generic example, and could apply to many situations.

9.2 Typical Application

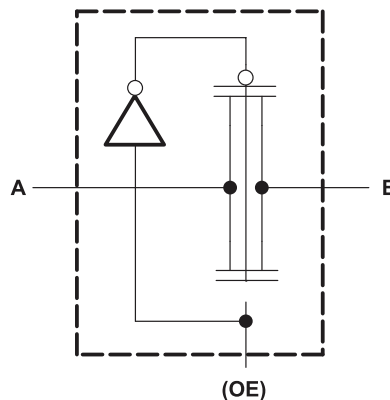

Figure 6. Simple Schematic

9.2.1 Design Requirements

1. Recommended Input Conditions:
 - For specified high and low levels, see V_{IH} and V_{IL} in Recommended Operating Conditions.
 - Inputs and outputs are overvoltage tolerant slowing them to go as high as 4.6 V at any valid VCC.
2. Recommended Output Conditions:
 - Load currents should not exceed ± 128 mA per channel.
3. Frequency Selection Criterion:
 - Maximum frequency tested is 200 MHz.

9.2.2 Detailed Design Procedure

The SN74CBTLV3383 can be operated without any external components. All inputs signals passing through the switch must fall within the recommend operating conditions of the SN74CBTLV3383 including signal range and continuous current. For this design example, with a supply of 3.3 V, the signals can range from 0 V to 3.3 V when the device is powered. The max continuous current can be 128 mA.

10 Power Supply Recommendations

The SN74CBTLV3383 operates across a wide supply range of 2.3 V to 3.6 V. Do not exceed the absolute maximum ratings because stresses beyond the listed ratings can cause permanent damage to the devices. Power-supply bypassing improves noise margin and prevents switching noise propagation from the VDD supply to other components. Good power-supply decoupling is important to achieve optimum performance. For improved supply noise immunity, use a supply decoupling capacitor ranging from 0.1 μF to 10 μF from VDD to ground. Place the bypass capacitors as close to the power supply pins of the device as possible using low-impedance connections. TI recommends using multi-layer ceramic chip capacitors (MLCCs) that offer low equivalent series resistance (ESR) and inductance (ESL) characteristics for power-supply decoupling purposes. For very sensitive systems, or for systems in harsh noise environments, avoiding the use of vias for connecting the capacitors to the device pins may offer superior noise immunity. The use of multiple vias in parallel lowers the overall inductance and is beneficial for connections to ground planes.

11 Layout

11.1 Layout Guidelines

Reflections and matching are closely related to the loop antenna theory but are different enough to be discussed separately from the theory. When a PCB trace turns a corner at a 90° angle, a reflection can occur. A reflection occurs primarily because of the change of width of the trace. At the apex of the turn, the trace width increases to 1.414 times the width. This increase upsets the transmission-line characteristics, especially the distributed capacitance and self-inductance of the trace which results in the reflection. Not all PCB traces can be straight and therefore some traces must turn corners. Figure 4 shows progressively better techniques of rounding corners. Only the last example (BEST) maintains constant trace width and minimizes reflections.

11.2 Layout Example

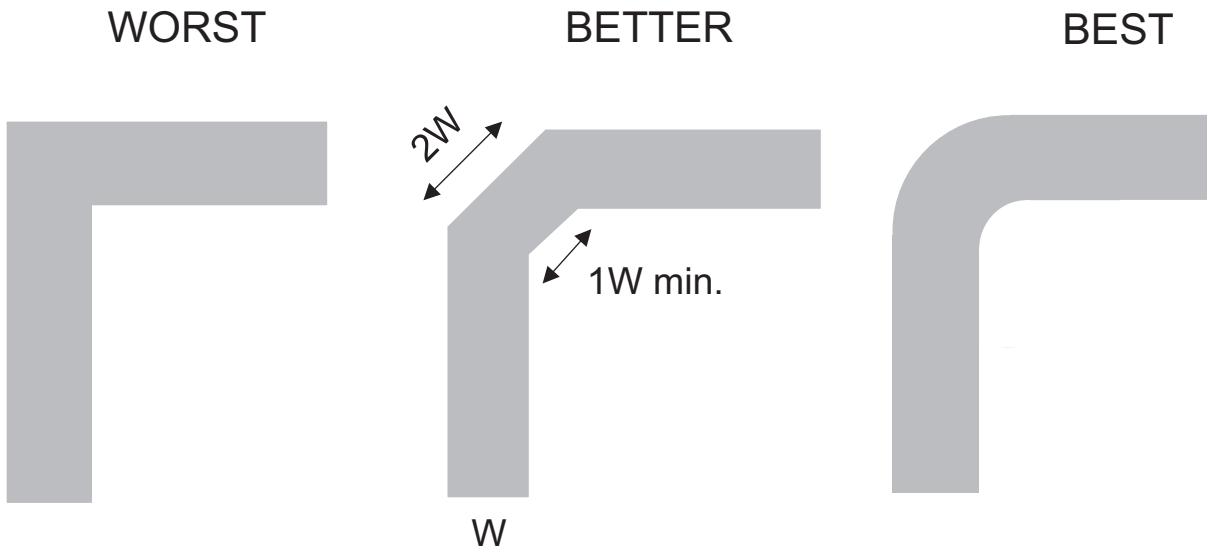

Figure 7. Example Layout

12 Device and Documentation Support

12.1 Documentation Support

12.2 Receiving Notification of Documentation Updates

To receive notification of documentation updates, navigate to the device product folder on ti.com. In the upper right corner, click on *Alert me* to register and receive a weekly digest of any product information that has changed. For change details, review the revision history included in any revised document.

12.3 Community Resources

The following links connect to TI community resources. Linked contents are provided "AS IS" by the respective contributors. They do not constitute TI specifications and do not necessarily reflect TI's views; see TI's [Terms of Use](#).

TI E2E™ Online Community *TI's Engineer-to-Engineer (E2E) Community*. Created to foster collaboration among engineers. At e2e.ti.com, you can ask questions, share knowledge, explore ideas and help solve problems with fellow engineers.

Design Support *TI's Design Support* Quickly find helpful E2E forums along with design support tools and contact information for technical support.

12.4 Trademarks

E2E is a trademark of Texas Instruments.
All other trademarks are the property of their respective owners.

12.5 Electrostatic Discharge Caution



This integrated circuit can be damaged by ESD. Texas Instruments recommends that all integrated circuits be handled with appropriate precautions. Failure to observe proper handling and installation procedures can cause damage.

ESD damage can range from subtle performance degradation to complete device failure. Precision integrated circuits may be more susceptible to damage because very small parametric changes could cause the device not to meet its published specifications.

12.6 Glossary

[SLYZ022](#) — *TI Glossary*.

This glossary lists and explains terms, acronyms, and definitions.

13 Mechanical, Packaging, and Orderable Information

The following pages include mechanical, packaging, and orderable information. This information is the most current data available for the designated devices. This data is subject to change without notice and revision of this document. For browser-based versions of this data sheet, refer to the left-hand navigation.

PACKAGING INFORMATION

Orderable Device	Status (1)	Package Type	Package Drawing	Pins	Package Qty	Eco Plan (2)	Lead/Ball Finish (6)	MSL Peak Temp (3)	Op Temp (°C)	Device Marking (4/5)	Samples
SN74CBTLV3383DBQR	ACTIVE	SSOP	DBQ	24	2500	Green (RoHS & no Sb/Br)	CU NIPDAU	Level-2-260C-1 YEAR	-40 to 85	CBTLV3383	Samples
SN74CBTLV3383DGVR	ACTIVE	TVSOP	DGV	24	2000	Green (RoHS & no Sb/Br)	CU NIPDAU	Level-1-260C-UNLIM	-40 to 85	CL383	Samples
SN74CBTLV3383DW	ACTIVE	SOIC	DW	24	25	Green (RoHS & no Sb/Br)	CU NIPDAU	Level-1-260C-UNLIM	-40 to 85	CBTLV3383	Samples
SN74CBTLV3383DWE4	ACTIVE	SOIC	DW	24	25	Green (RoHS & no Sb/Br)	CU NIPDAU	Level-1-260C-UNLIM	-40 to 85	CBTLV3383	Samples
SN74CBTLV3383DWR	ACTIVE	SOIC	DW	24	2000	Green (RoHS & no Sb/Br)	CU NIPDAU	Level-1-260C-UNLIM	-40 to 85	CBTLV3383	Samples
SN74CBTLV3383PW	ACTIVE	TSSOP	PW	24	60	Green (RoHS & no Sb/Br)	CU NIPDAU	Level-1-260C-UNLIM	-40 to 85	CL383	Samples
SN74CBTLV3383PWG4	ACTIVE	TSSOP	PW	24	60	Green (RoHS & no Sb/Br)	CU NIPDAU	Level-1-260C-UNLIM	-40 to 85	CL383	Samples
SN74CBTLV3383PWR	ACTIVE	TSSOP	PW	24	2000	Green (RoHS & no Sb/Br)	CU NIPDAU	Level-1-260C-UNLIM	-40 to 85	CL383	Samples

(1) The marketing status values are defined as follows:

ACTIVE: Product device recommended for new designs.

LIFEBUY: TI has announced that the device will be discontinued, and a lifetime-buy period is in effect.

NRND: Not recommended for new designs. Device is in production to support existing customers, but TI does not recommend using this part in a new design.

PREVIEW: Device has been announced but is not in production. Samples may or may not be available.

OBSOLETE: TI has discontinued the production of the device.

(2) **RoHS:** TI defines "RoHS" to mean semiconductor products that are compliant with the current EU RoHS requirements for all 10 RoHS substances, including the requirement that RoHS substance do not exceed 0.1% by weight in homogeneous materials. Where designed to be soldered at high temperatures, "RoHS" products are suitable for use in specified lead-free processes. TI may reference these types of products as "Pb-Free".

RoHS Exempt: TI defines "RoHS Exempt" to mean products that contain lead but are compliant with EU RoHS pursuant to a specific EU RoHS exemption.

Green: TI defines "Green" to mean the content of Chlorine (Cl) and Bromine (Br) based flame retardants meet JS709B low halogen requirements of <=100ppm threshold. Antimony trioxide based flame retardants must also meet the <=1000ppm threshold requirement.

(3) MSL, Peak Temp. - The Moisture Sensitivity Level rating according to the JEDEC industry standard classifications, and peak solder temperature.

(4) There may be additional marking, which relates to the logo, the lot trace code information, or the environmental category on the device.

⁽⁵⁾ Multiple Device Markings will be inside parentheses. Only one Device Marking contained in parentheses and separated by a "-" will appear on a device. If a line is indented then it is a continuation of the previous line and the two combined represent the entire Device Marking for that device.

⁽⁶⁾ Lead/Ball Finish - Orderable Devices may have multiple material finish options. Finish options are separated by a vertical ruled line. Lead/Ball Finish values may wrap to two lines if the finish value exceeds the maximum column width.

Important Information and Disclaimer:The information provided on this page represents TI's knowledge and belief as of the date that it is provided. TI bases its knowledge and belief on information provided by third parties, and makes no representation or warranty as to the accuracy of such information. Efforts are underway to better integrate information from third parties. TI has taken and continues to take reasonable steps to provide representative and accurate information but may not have conducted destructive testing or chemical analysis on incoming materials and chemicals. TI and TI suppliers consider certain information to be proprietary, and thus CAS numbers and other limited information may not be available for release.

In no event shall TI's liability arising out of such information exceed the total purchase price of the TI part(s) at issue in this document sold by TI to Customer on an annual basis.

TAPE AND REEL BOX DIMENSIONS



*All dimensions are nominal

Device	Package Type	Package Drawing	Pins	SPQ	Length (mm)	Width (mm)	Height (mm)
SN74CBTLV3383DBQR	SSOP	DBQ	24	2500	367.0	367.0	38.0
SN74CBTLV3383DGVR	TVSOP	DGV	24	2000	367.0	367.0	35.0
SN74CBTLV3383DWR	SOIC	DW	24	2000	350.0	350.0	43.0
SN74CBTLV3383PWR	TSSOP	PW	24	2000	367.0	367.0	38.0

DBQ (R-PDSO-G24)

PLASTIC SMALL-OUTLINE PACKAGE

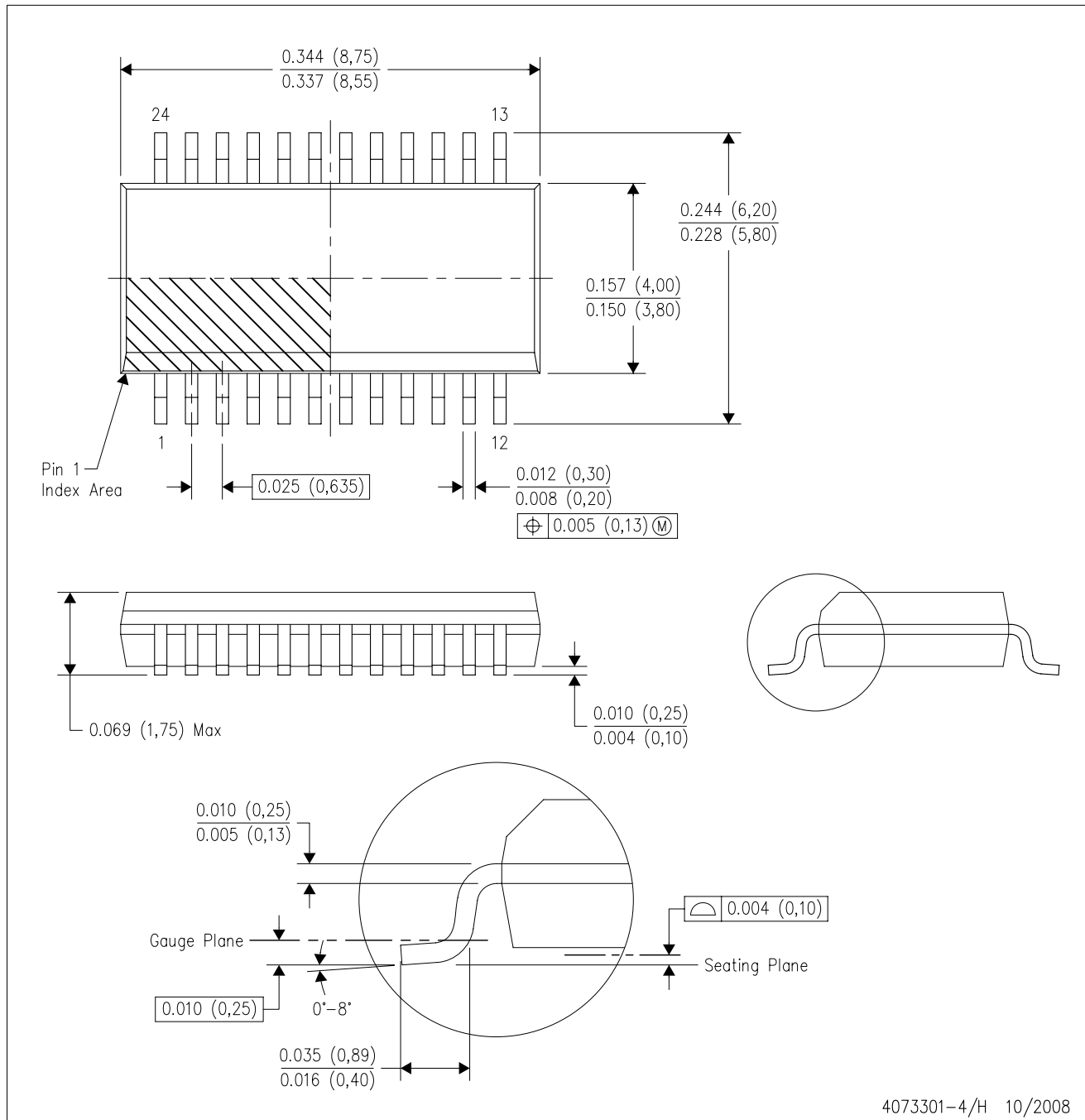

- NOTES:
- A. All linear dimensions are in inches (millimeters).
 - B. This drawing is subject to change without notice.
 - C. Body dimensions do not include mold flash or protrusion not to exceed 0.006 (0,15) per side.
 - D. Falls within JEDEC MO-137 variation AE.

EXAMPLE BOARD LAYOUT

PW0024A

TSSOP - 1.2 mm max height

SMALL OUTLINE PACKAGE

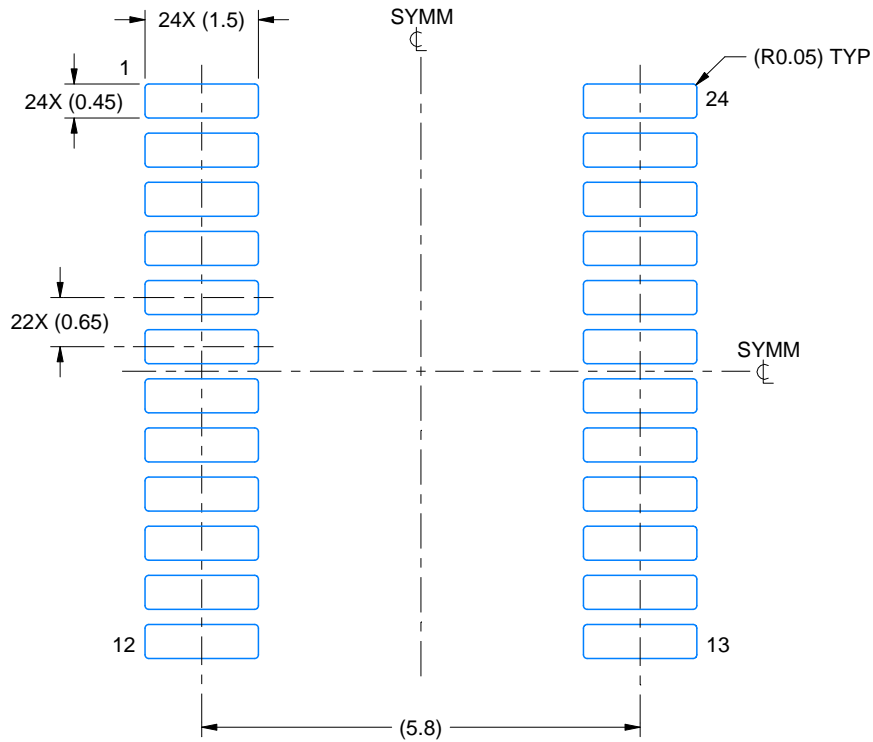

LAND PATTERN EXAMPLE
EXPOSED METAL SHOWN
SCALE: 10X

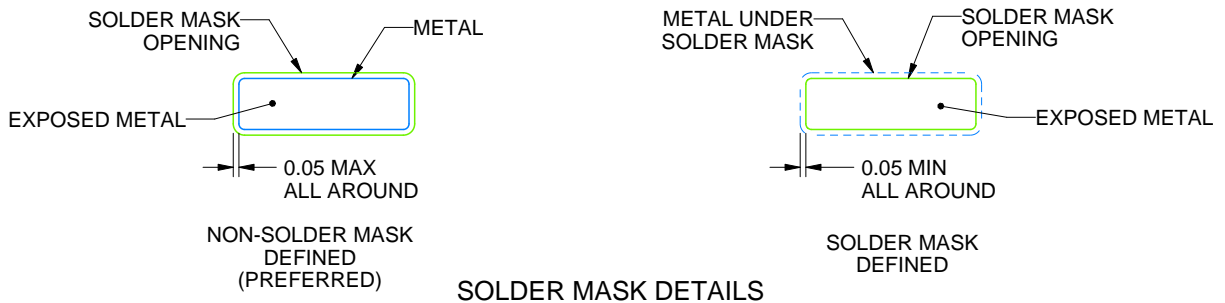

SOLDER MASK DETAILS

4220208/A 02/2017

NOTES: (continued)

- 6. Publication IPC-7351 may have alternate designs.
- 7. Solder mask tolerances between and around signal pads can vary based on board fabrication site.

EXAMPLE STENCIL DESIGN

PW0024A

TSSOP - 1.2 mm max height

SMALL OUTLINE PACKAGE

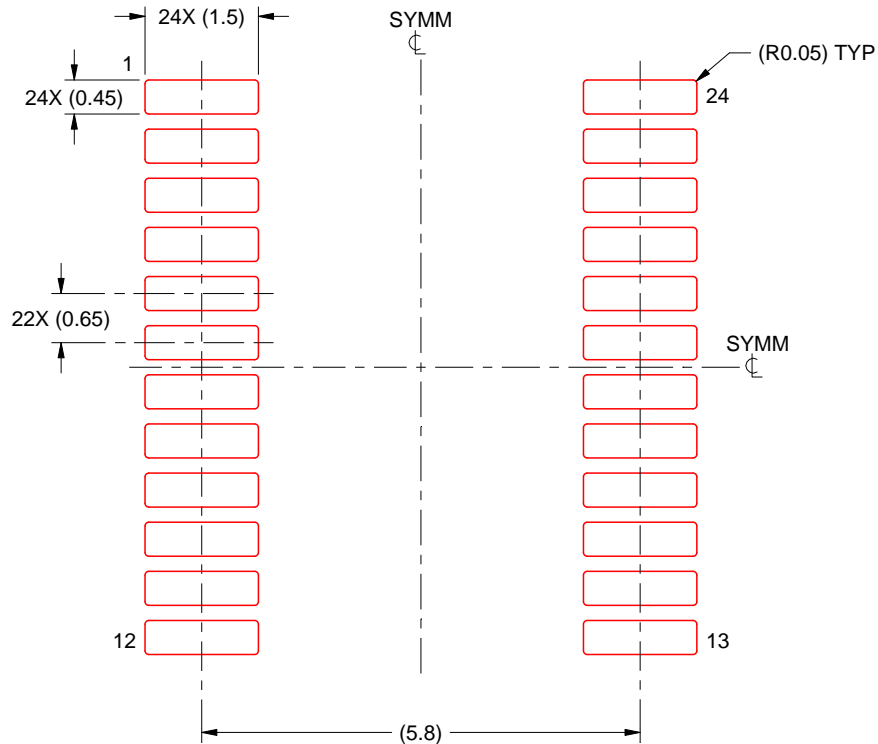

SOLDER PASTE EXAMPLE
BASED ON 0.125 mm THICK STENCIL
SCALE: 10X

4220208/A 02/2017

NOTES: (continued)

8. Laser cutting apertures with trapezoidal walls and rounded corners may offer better paste release. IPC-7525 may have alternate design recommendations.
9. Board assembly site may have different recommendations for stencil design.

DGV (R-PDSO-G**)

PLASTIC SMALL-OUTLINE

24 PINS SHOWN



- NOTES: A. All linear dimensions are in millimeters.
 B. This drawing is subject to change without notice.
 C. Body dimensions do not include mold flash or protrusion, not to exceed 0,15 per side.
 D. Falls within JEDEC: 24/48 Pins – MO-153
 14/16/20/56 Pins – MO-194

DW (R-PDSO-G24)

PLASTIC SMALL OUTLINE

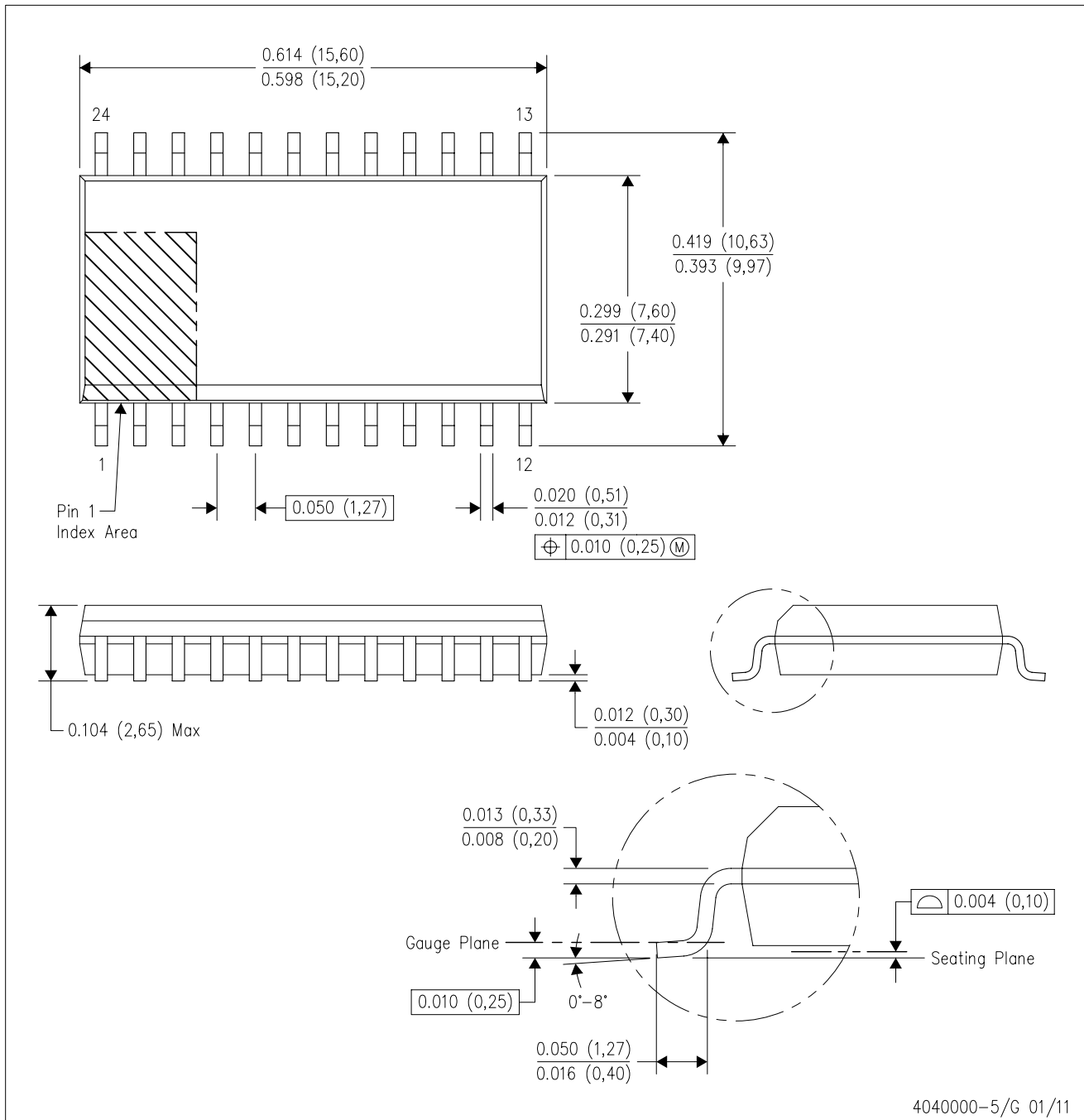

- NOTES:
- A. All linear dimensions are in inches (millimeters). Dimensioning and tolerancing per ASME Y14.5M-1994.
 - B. This drawing is subject to change without notice.
 - C. Body dimensions do not include mold flash or protrusion not to exceed 0.006 (0,15).
 - D. Falls within JEDEC MS-013 variation AD.

IMPORTANT NOTICE AND DISCLAIMER

TI PROVIDES TECHNICAL AND RELIABILITY DATA (INCLUDING DATASHEETS), DESIGN RESOURCES (INCLUDING REFERENCE DESIGNS), APPLICATION OR OTHER DESIGN ADVICE, WEB TOOLS, SAFETY INFORMATION, AND OTHER RESOURCES "AS IS" AND WITH ALL FAULTS, AND DISCLAIMS ALL WARRANTIES, EXPRESS AND IMPLIED, INCLUDING WITHOUT LIMITATION ANY IMPLIED WARRANTIES OF MERCHANTABILITY, FITNESS FOR A PARTICULAR PURPOSE OR NON-INFRINGEMENT OF THIRD PARTY INTELLECTUAL PROPERTY RIGHTS.

These resources are intended for skilled developers designing with TI products. You are solely responsible for (1) selecting the appropriate TI products for your application, (2) designing, validating and testing your application, and (3) ensuring your application meets applicable standards, and any other safety, security, or other requirements. These resources are subject to change without notice. TI grants you permission to use these resources only for development of an application that uses the TI products described in the resource. Other reproduction and display of these resources is prohibited. No license is granted to any other TI intellectual property right or to any third party intellectual property right. TI disclaims responsibility for, and you will fully indemnify TI and its representatives against, any claims, damages, costs, losses, and liabilities arising out of your use of these resources.

TI's products are provided subject to TI's Terms of Sale (www.ti.com/legal/termsofsale.html) or other applicable terms available either on ti.com or provided in conjunction with such TI products. TI's provision of these resources does not expand or otherwise alter TI's applicable warranties or warranty disclaimers for TI products.

Mailing Address: Texas Instruments, Post Office Box 655303, Dallas, Texas 75265
Copyright © 2019, Texas Instruments Incorporated

Looking for pricing, stock, or lifecycle information?

Click below to explore more details on WIN SOURCE:

 [View SN74CBTLV3383PWR on WIN SOURCE](#)

 [Texas Instruments](#) Information

Optimize Your Supply Chain with WIN SOURCE Solutions

-  Global Sourcing Solution
-  Obsolete Management
-  Cost Control Management
-  Shortage Management
-  Alternative Solution
-  Excess Inventory Management