



**THE DATASHEET OF
SN74CB3T3245DBQR**



SN74CB3T3245 8-Bit FET Bus Switch 2.5-V and 3.3-V Low-Voltage With 5-V-Tolerant Level Shifter

1 Features

- Standard '245-Type Pinout
- Output Voltage Translation Tracks V_{CC}
- Supports Mixed-Mode Signal Operation on All Data I/O Ports
 - 5-V Input Down to 3.3-V Output Level Shift With 3.3-V V_{CC}
 - 5-V/3.3-V Input Down to 2.5-V Output Level Shift With 2.5-V V_{CC}
- 5-V-Tolerant I/Os With Device Powered Up or Powered Down
- Bidirectional Data Flow With Near-Zero Propagation Delay
- Low ON-State Resistance (r_{on}) Characteristics ($r_{on} = 5 \Omega$ Typical)
- Low Input/Output Capacitance Minimizes Loading ($C_{io(OFF)} = 5 \text{ pF}$ Typical)
- Data and Control Inputs Provide Undershoot Clamp Diodes
- Low Power Consumption ($I_{CC} = 40 \mu\text{A}$ Maximum)
- V_{CC} Operating Range From 2.3 V to 3.6 V
- Data I/Os Support 0- to 5-V Signaling Levels (0.8 V, 1.2 V, 1.5 V, 1.8 V, 2.5 V, 3.3 V, 5 V)
- Control Inputs Can Be Driven by TTL or 5-V/3.3-V CMOS Outputs
- I_{off} Supports Partial-Power-Down Mode Operation

- Latch-Up Performance Exceeds 250 mA Per JESD 17
- ESD Performance Tested Per JESD 22
 - 2000-V Human-Body Model (A114-B, Class II)
 - 1000-V Charged-Device Model (C101)
- Ideal for Low-Power Portable Equipment

2 Applications

- Supports Digital Applications: Level Translation, PCI Interface, USB Interface, Memory Interleaving, Bus Isolation

3 Description

The SN74CB3T3245 device is a high-speed TTL-compatible 8-bit FET bus switch with low ON-state resistance (r_{on}), allowing for minimal propagation delay. The device fully supports mixed-mode signal operation on all data I/O ports by providing voltage translation that tracks V_{CC} .

Device Information⁽¹⁾

PART NUMBER	PACKAGE	BODY SIZE (NOM)
SN74CB3T3245DBQ	SSOP (20)	8.65 mm x 3.90 mm
SN74CB3T3245DGV	TVSOP (20)	5.00 mm x 4.40 mm
SN74CB3T3245DW	SOIC (20)	12.80 mm x 7.50 mm
SN74CB3T3245PW	TSSOP (20)	6.50 mm x 4.40 mm

(1) For all available packages, see the orderable addendum at the end of the data sheet.

Typical Application Functional Diagram

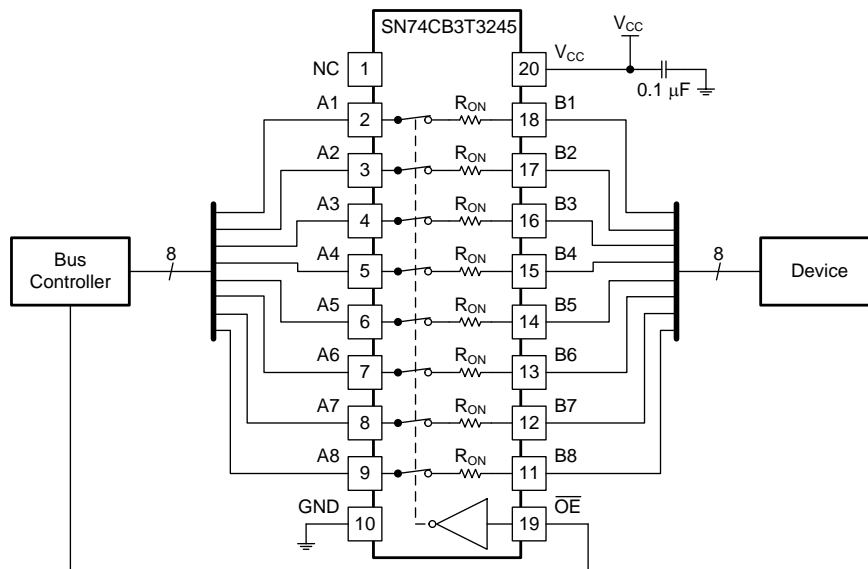

Table of Contents

1 Features	1	8.3 Feature Description	9
2 Applications	1	8.4 Device Functional Modes	9
3 Description	1	9 Application and Implementation	10
4 Revision History	2	9.1 Application Information	10
5 Pin Configuration and Functions	3	9.2 Typical Application	10
6 Specifications	4	10 Power Supply Recommendations	11
6.1 Absolute Maximum Ratings	4	11 Layout	11
6.2 ESD Ratings	4	11.1 Layout Guidelines	11
6.3 Recommended Operating Conditions	4	11.2 Layout Example	11
6.4 Thermal Information	4	12 Device and Documentation Support	12
6.5 Electrical Characteristics	5	12.1 Documentation Support	12
6.6 Switching Characteristics	5	12.2 Receiving Notification of Documentation Updates	12
6.7 Typical Characteristics	6	12.3 Community Resources	12
7 Parameter Measurement Information	7	12.4 Trademarks	12
8 Detailed Description	8	12.5 Electrostatic Discharge Caution	12
8.1 Overview	8	12.6 Glossary	12
8.2 Functional Block Diagram	8	13 Mechanical, Packaging, and Orderable Information	12

4 Revision History

NOTE: Page numbers for previous revisions may differ from page numbers in the current version.

Changes from Revision B (June 2015) to Revision C	Page
• Changed the pin out image appearance	3
• Changed $I_O = 1\text{ mA}$ To: $I_O = 1\text{ }\mu\text{A}$ in Figure 9 and Figure 10	11

Changes from Revision A (August 2012) to Revision B	Page
• Added <i>Applications</i> , <i>Device Information</i> table, <i>Pin Configuration and Functions</i> section, <i>ESD Ratings</i> table, <i>Feature Description</i> section, <i>Device Functional Modes</i> , <i>Application and Implementation</i> section, <i>Power Supply Recommendations</i> section, <i>Layout</i> section, <i>Device and Documentation Support</i> section, and <i>Mechanical, Packaging, and Orderable Information</i> section	1
• Removed <i>Ordering Information</i> table.	1

Changes from Original (March 2005) to Revision A	Page
• Updated graphic note and picture in Figure 1	8

5 Pin Configuration and Functions

**DBQ, DGV, DW, and PW Package
20-Pin SSOP, TVSOP, SOIC, TSSOP
Top View**

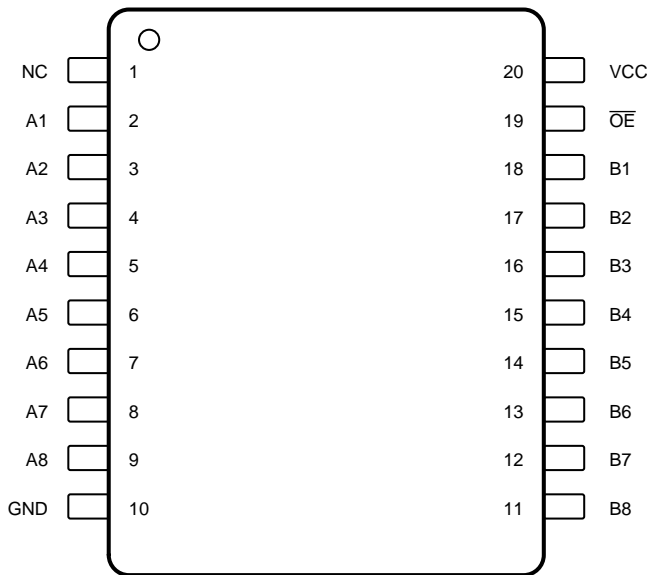

Not to scale

NC — No internal connection

Pin Functions

PIN		I/O	DESCRIPTION
NO.	NAME		
1	NC	—	Not internally connected
2	A1	I/O	Switch 1 A terminal
3	A2	I/O	Switch 2 A terminal
4	A3	I/O	Switch 3 A terminal
5	A4	I/O	Switch 4 A terminal
6	A5	I/O	Switch 5 A terminal
7	A6	I/O	Switch 6 A terminal
8	A7	I/O	Switch 7 A terminal
9	A8	I/O	Switch 8 A terminal
10	GND	—	Ground
11	B8	I/O	Switch 8 B terminal
12	B7	I/O	Switch 7 B terminal
13	B6	I/O	Switch 6 B terminal
14	B5	I/O	Switch 5 B terminal
15	B4	I/O	Switch 4 B terminal
16	B3	I/O	Switch 3 B terminal
17	B2	I/O	Switch 2 B terminal
18	B1	I/O	Switch 1 B terminal
19	\overline{OE}	I	Output enable, active low
20	V _{CC}	—	Power

6 Specifications

6.1 Absolute Maximum Ratings

 over operating free-air temperature range (unless otherwise noted)⁽¹⁾

		MIN	MAX	UNIT
V _{CC}	Supply voltage ⁽²⁾	-0.5	7	V
V _{IN}	Control input voltage ⁽²⁾⁽³⁾	-0.5	7	V
V _{I/O}	Switch I/O voltage ⁽²⁾⁽³⁾⁽⁴⁾	-0.5	7	V
I _{IK}	Control input clamp current	V _{IN} < 0	-50	mA
I _{I/O}	I/O port clamp current	V _{I/O} < 0	-50	mA
I _{I/O}	ON-state switch current ⁽⁵⁾		±128	mA
	Continuous current through V _{CC} or GND		±100	mA
T _J	Junction temperature		150	°C
T _{stg}	Storage temperature	-65	150	

- (1) Stresses beyond those listed under *Absolute Maximum Ratings* may cause permanent damage to the device. These are stress ratings only, and functional operation of the device at these or any other conditions beyond those indicated under *Recommended Operating Conditions* is not implied. Exposure to absolute-maximum-rated conditions for extended periods may affect device reliability.
- (2) All voltages are with respect to ground unless otherwise specified.
- (3) The input and output voltage ratings may be exceeded if the input and output clamp-current ratings are observed.
- (4) V_I and V_O are used to denote specific conditions for V_{I/O}.
- (5) I_I and I_O are used to denote specific conditions for I_{I/O}.

6.2 ESD Ratings

		VALUE	UNIT
V _(ESD)	Electrostatic discharge	Human-body model (HBM), per ANSI/ESDA/JEDEC JS-001 ⁽¹⁾	V
		Charged-device model (CDM), per JEDEC specification JESD22-C101 ⁽²⁾	
		±2000	
		±1000	

- (1) JEDEC document JEP155 states that 500-V HBM allows safe manufacturing with a standard ESD control process.
- (2) JEDEC document JEP157 states that 250-V CDM allows safe manufacturing with a standard ESD control process.

6.3 Recommended Operating Conditions

 over operating free-air temperature range (unless otherwise noted)⁽¹⁾

		MIN	MAX	UNIT	
V _{CC}	Supply voltage	2.3	3.6	V	
V _{IH}	High-level control input voltage	V _{CC} = 2.3 V to 2.7 V	1.7	5.5	V
		V _{CC} = 2.7 V to 3.6 V	2	5.5	
V _{IL}	Low-level control input voltage	V _{CC} = 2.3 V to 2.7 V	0	0.7	V
		V _{CC} = 2.7 V to 3.6 V	0	0.8	
V _{I/O}	Data input/output voltage	0	5.5	V	
T _A	Operating free-air temperature	-40	85	°C	

- (1) All unused control inputs of the device must be held at V_{CC} or GND to ensure proper device operation. Refer to the TI application report, *Implications of Slow or Floating CMOS Inputs*, literature number [SCBA004](#).

6.4 Thermal Information

THERMAL METRIC ⁽¹⁾	SN74CB3T3245				UNIT	
	DBQ (SSOP)	DGV (TVSOP)	DW (SOIC)	PW (TSSOP)		
	20 PINS	20 PINS	20 PINS	20 PINS		
R _{θJA}	Junction-to-ambient thermal resistance	68	92	58	83	°C/W

- (1) For more information about traditional and new thermal metrics, see the *Semiconductor and IC Package Thermal Metrics* application report.

6.5 Electrical Characteristics

over recommended operating free-air temperature range (unless otherwise noted)⁽¹⁾

PARAMETER		TEST CONDITIONS	MIN	TYP ⁽²⁾	MAX	UNIT	
V _{IK}		V _{CC} = 3 V, I _I = -18 mA			-1.2	V	
V _{OH}		See and Figure 1					
I _{IN}	Control inputs	V _{CC} = 3.6 V, V _{IN} = 3.6 V to 5.5 V or GND			±10	μA	
I _I		V _{CC} = 3.6 V, Switch ON, V _{IN} = V _{CC} or GND	V _I = V _{CC} - 0.7 V to 5.5 V		±20	μA	
			V _I = 0.7 V to V _{CC} - 0.7 V		-40		
			V _I = 0 to 0.7 V		±5		
I _{OZ} ⁽³⁾		V _{CC} = 3.6 V, V _O = 0 to 5.5 V, V _I = 0, Switch OFF, V _{IN} = V _{CC} or GND			±10	μA	
I _{off}		V _{CC} = 0, V _O = 0 to 5.5 V, V _I = 0,			10	μA	
I _{CC}		V _{CC} = 3.6 V, I _{I/O} = 0, Switch ON or OFF, V _{IN} = V _{CC} or GND	V _I = V _{CC} or GND		40	μA	
			V _I = 5.5 V		40		
ΔI _{CC} ⁽⁴⁾	Control inputs	V _{CC} = 3 V to 3.6 V, One input at V _{CC} - 0.6 V, Other inputs at V _{CC} or GND			300	μA	
C _{in}	Control inputs	V _{CC} = 3.3 V, V _{IN} = V _{CC} or GND		4		pF	
C _{io(OFF)}		V _{CC} = 3.3 V, V _{I/O} = 5.5 V, 3.3 V, or GND, Switch OFF, V _{IN} = V _{CC} or GND		5		pF	
C _{io(ON)}		V _{CC} = 3.3 V, Switch ON, V _{IN} = V _{CC} or GND	V _{I/O} = 5.5 V or 3.3 V		5	pF	
			V _{I/O} = GND		13		
r _{on} ⁽⁵⁾		V _{CC} = 2.3 V, TYP at V _{CC} = 2.5 V, V _I = 0	I _O = 24 mA		5	8.5	Ω
			I _O = 16 mA		5	8.5	
		V _{CC} = 3 V, V _I = 0	I _O = 64 mA		5	7	
			I _O = 32 mA		5	7	

(1) V_{IN} and I_{IN} refer to control inputs. V_I, V_O, I_I, and I_O refer to data pins.

(2) All typical values are at V_{CC} = 3.3 V (unless otherwise noted), T_A = 25°C.

(3) For I/O ports, the parameter I_{OZ} includes the input leakage current.

(4) This is the increase in supply current for each input that is at the specified TTL voltage level, rather than V_{CC} or GND.

(5) Measured by the voltage drop between A and B terminals at the indicated current through the switch. ON-state resistance is determined by the lower of the voltages of the two (A or B) terminals.

6.6 Switching Characteristics

over recommended operating free-air temperature range (unless otherwise noted) (see [Figure 4](#))

PARAMETER	FROM (INPUT)	TO (OUTPUT)	V _{CC} = 2.5 V ± 0.2 V		V _{CC} = 3.3 V ± 0.3 V		UNIT
			MIN	MAX	MIN	MAX	
t _{pd} ⁽¹⁾	A or B	B or A		0.15		0.25	ns
t _{en}	\overline{OE}	A or B	1	10.5	1	8	ns
t _{dis}	\overline{OE}	A or B	1	5.5	1	7.5	ns

(1) The propagation delay is the calculated RC time constant of the typical ON-state resistance of the switch and the specified load capacitance, when driven by an ideal voltage source (zero output impedance).

6.7 Typical Characteristics

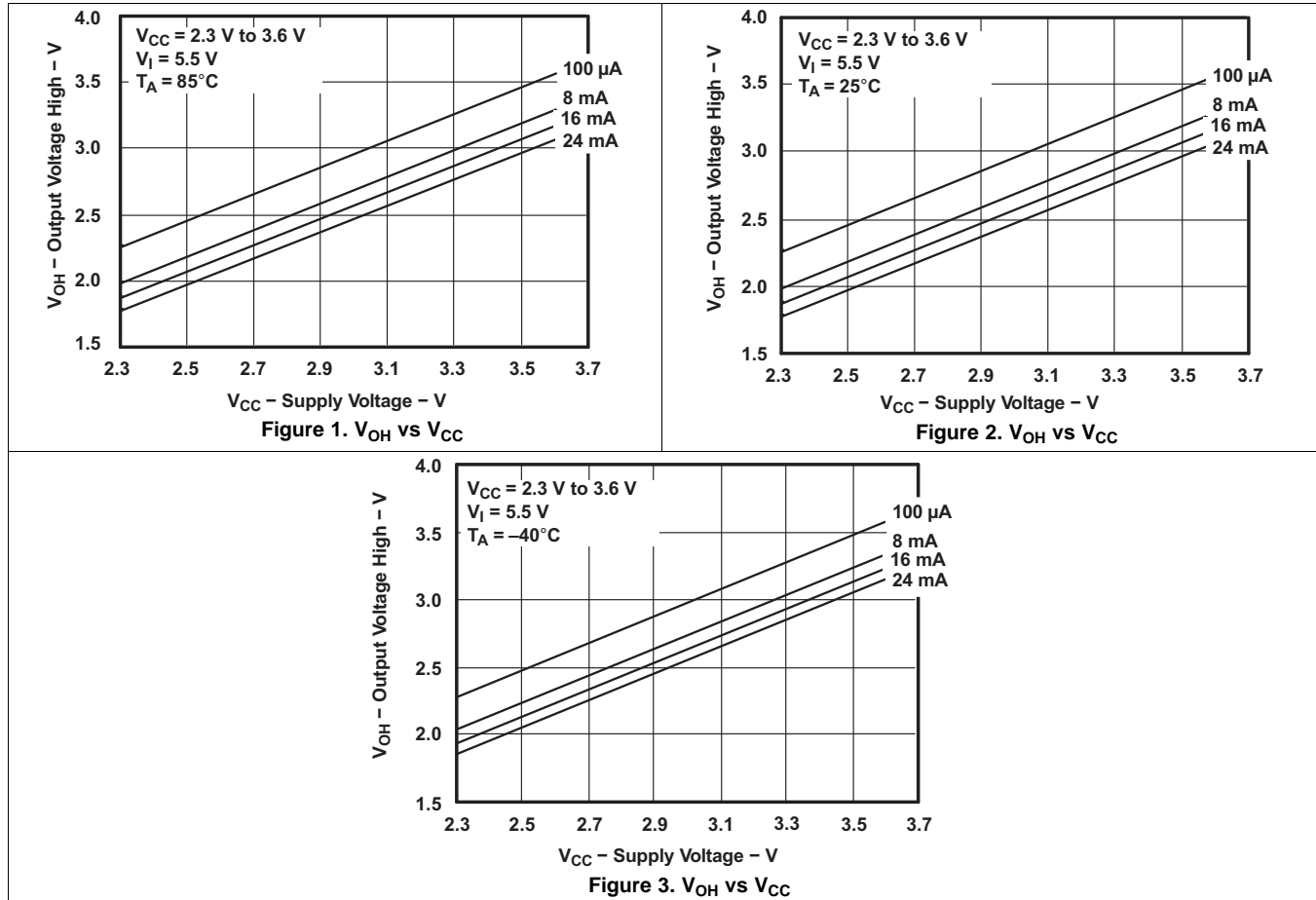

7 Parameter Measurement Information

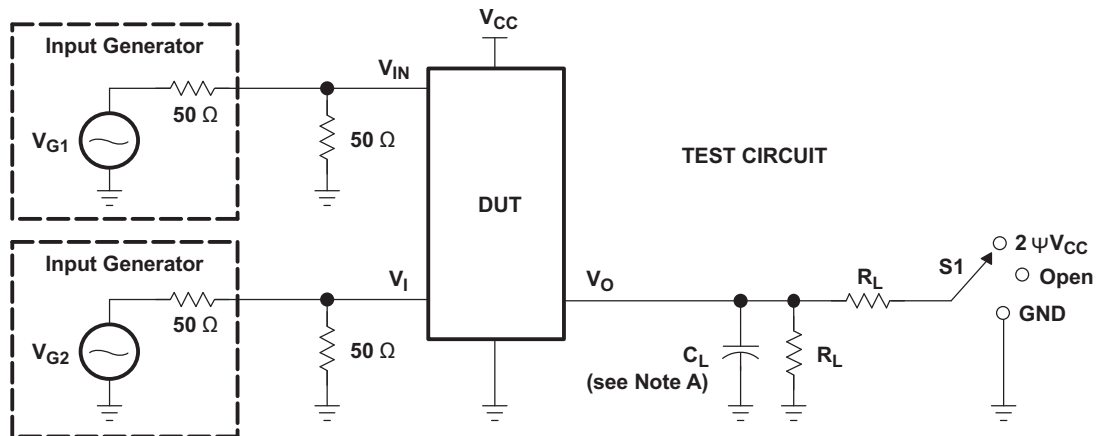

TEST	V _{CC}	S1	R _L	V _I	C _L	V _Δ
t _{pd(s)}	2.5 V ± 0.2 V	Open	500 Ω	3.6 V or GND	30 pF	
	3.3 V ± 0.3 V	Open	500 Ω	5.5 V or GND	50 pF	
t _{PLZ} /t _{PZL}	2.5 V ± 0.2 V	2 × V _{CC}	500 Ω	GND	30 pF	0.15 V
	3.3 V ± 0.3 V	2 × V _{CC}	500 Ω	GND	50 pF	0.3 V
t _{PHZ} /t _{PZH}	2.5 V ± 0.2 V	Open	500 Ω	3.6 V	30 pF	0.15 V
	3.3 V ± 0.3 V	Open	500 Ω	5.5 V	50 pF	0.3 V

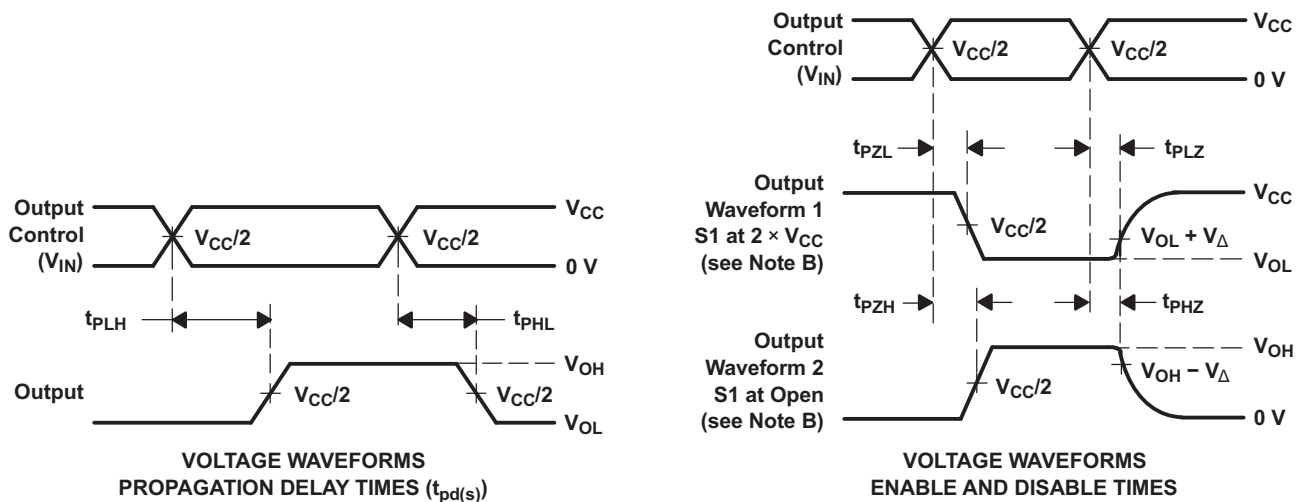

- NOTES:
- A. C_L includes probe and jig capacitance.
 - B. Waveform 1 is for an output with internal conditions such that the output is low except when disabled by the output control. Waveform 2 is for an output with internal conditions such that the output is high, except when disabled by the output control.
 - C. All input pulses are supplied by generators having the following characteristics: PRR ≤ 10 MHz, Z_O = 50 Ω, t_r ≤ 2.5 ns, t_f ≤ 2.5 ns.
 - D. The outputs are measured one at a time, with one transition per measurement.
 - E. t_{PLZ} and t_{PHZ} are the same as t_{dis}.
 - F. t_{PZL} and t_{PZH} are the same as t_{en}.
 - G. t_{PLH} and t_{PHL} are the same as t_{pd(s)}. The t_{pd} propagation delay is the calculated RC time constant of the typical ON-state resistance of the switch and the specified load capacitance, when driven by an ideal voltage source (zero output impedance).
 - H. All parameters and waveforms are not applicable to all devices.

Figure 4. Test Circuit and Voltage Waveforms

8 Detailed Description

8.1 Overview

The SN74CB3T3245 device is a high-speed TTL-compatible FET bus switch with low ON-state resistance (r_{on}), allowing for minimal propagation delay. The device fully supports mixed-mode signal operation on all data I/O ports by providing voltage translation that tracks V_{CC} . The SN74CB3T3245 device supports systems using 5-V TTL, 3.3-V LVTTTL, and 2.5-V CMOS switching standards, as well as user-defined switching levels (see [Figure 5](#)).

The SN74CB3T3245 device is an 8-bit bus switch with a single output-enable (\overline{OE}) input and a standard '245 pinout. When \overline{OE} is low, the 8-bit bus switch is ON, and the A port is connected to the B port, allowing bidirectional data flow between ports. When \overline{OE} is high, the 8-bit bus switch is OFF, and a high-impedance state exists between the A and B ports.

This device is fully specified for partial-power-down applications using I_{off} . The I_{off} feature ensures that damaging current will not backflow through the device when it is powered down. The device has isolation during power off.

To ensure the high-impedance state during power up or power down, \overline{OE} should be tied to V_{CC} through a pullup resistor; the minimum value of the resistor is determined by the current-sinking capability of the driver.

8.2 Functional Block Diagram

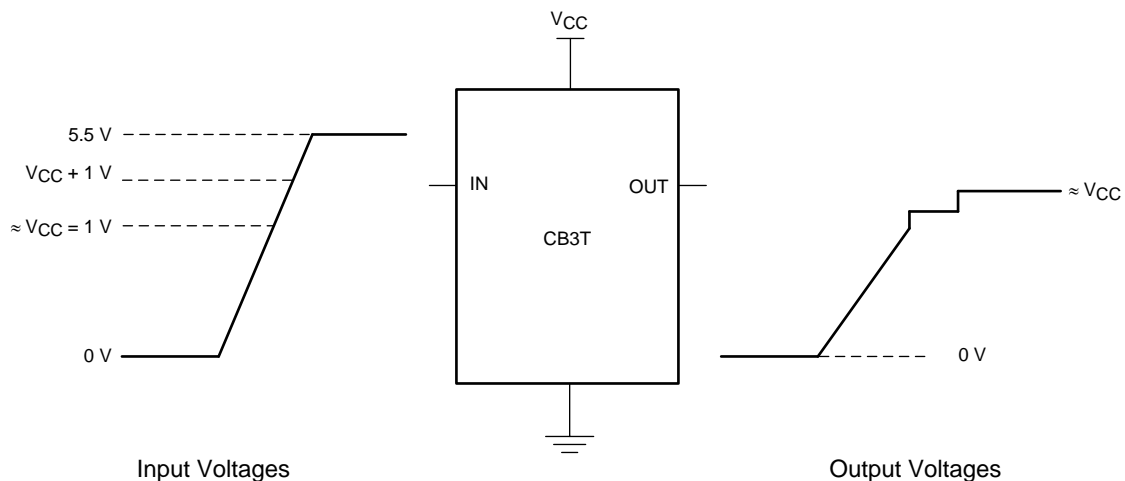

If the input high voltage (V_{IH}) level is greater than or equal to $V_{CC} + 1V$, and less than or equal to 5.5V, the output high voltage (V_{OH}) level will be equal to approximately the V_{CC} voltage level.

Figure 5. Typical DC Voltage Translation Characteristics

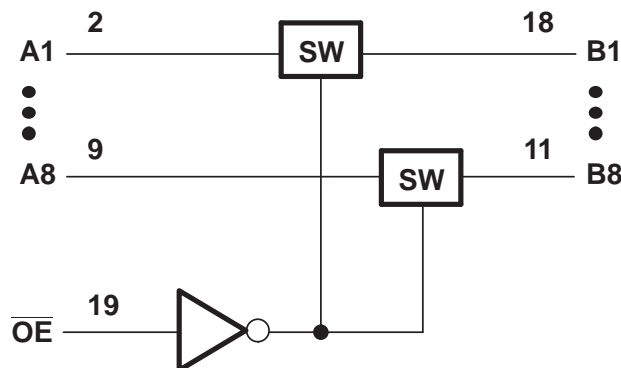
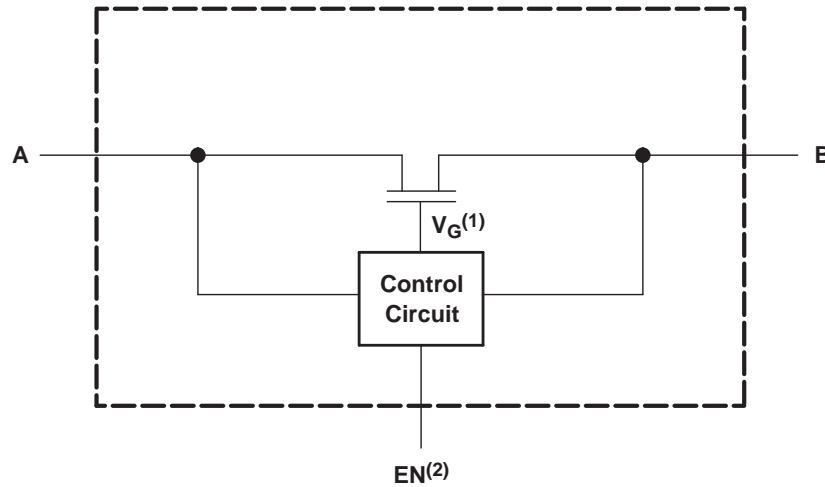

Figure 6. Logic Diagram (Positive Logic)

Functional Block Diagram (continued)



- 1) Gate Voltage (V_G) is approximately equal to $V_{CC} + V_T$ when the switch is ON and $V_I > (V_{CC} + V_T)$.
- 2) EN is the internal enable signal applied to the switch.

Figure 7. Simplified Schematic, Each FET Switch (SW)

8.3 Feature Description

The SN74CB3T3245 device uses the standard '245-type pinout. The output voltage tracks V_{CC} , allowing for easy down-translation. The device is ideal for low-power portable equipment.

Mixed-mode signal operation is supported on all data I/O ports. 5-V input down to 3.3-V output level shift with 3.3-V V_{CC} and 5-V/3.3-V input down to 2.5-V output level shift With 2.5-V V_{CC} are possible due to overvoltage tolerant inputs.

This part is friendly to partial power down systems. The I/Os are 5-V-tolerant with the device powered up or powered down and I_{off} supports partial-power-down mode operation

The SN74CB3T3245 has a bidirectional data flow with near-zero propagation delay.

The SN74CB3T3245 has low ON-state resistance (r_{on}) characteristics ($r_{on} = 5 \Omega$ Typical)

The SN74CB3T3245 has both low input and output capacitance minimizes loading ($C_{io(OFF)} = 5 \text{ pF}$ Typical)

Data and control inputs provide undershoot clamp diodes.

The SN74CB3T3245 has low power consumption ($I_{CC} = 40 \mu\text{A}$ Maximum)

The SN74CB3T3245 has a V_{CC} operating range from 2.3 V to 3.6 V.

The data I/Os support 0- to 5-V signaling levels (0.8-V, 1.2-V, 1.5-V, 1.8-V, 2.5-V, 3.3-V, 5-V)

Control inputs can be driven by TTL or 5-V/3.3-V CMOS outputs

8.4 Device Functional Modes

Table 1 lists the functional modes of the SN74CB3T3245.

Table 1. Function Table

INPUT OE	INPUT/OUTPUT A	FUNCTION
L	B	A port = B port
H	Z	Disconnect

9 Application and Implementation

NOTE

Information in the following applications sections is not part of the TI component specification, and TI does not warrant its accuracy or completeness. TI's customers are responsible for determining suitability of components for their purposes. Customers should validate and test their design implementation to confirm system functionality.

9.1 Application Information

This application is specifically to connect a 5-V bus to a 3.3-V device. It is assumed that communication in this particular application is one-directional, going from the bus controller to the device.

9.2 Typical Application

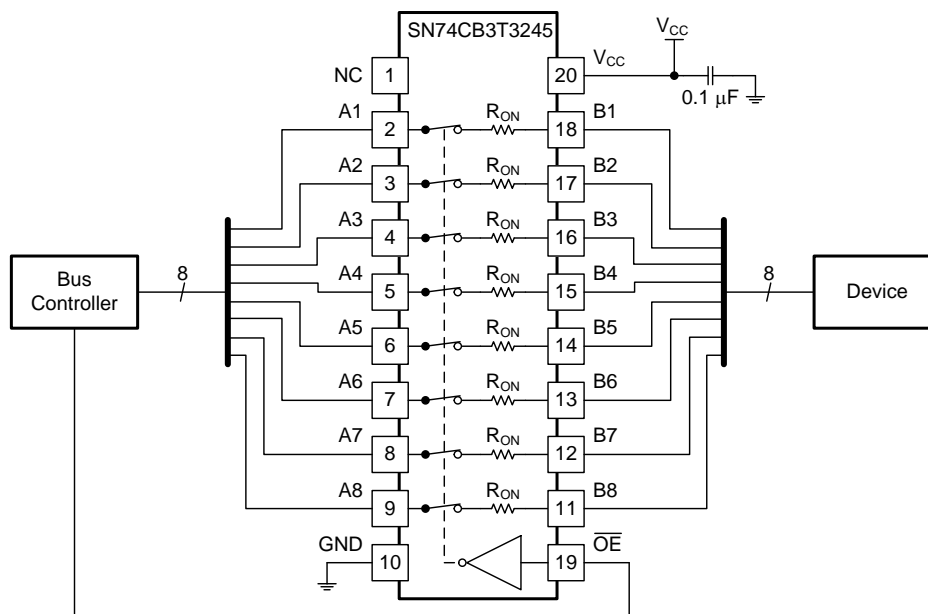

Figure 8. Typical Application Schematic

9.2.1 Design Requirements

This device uses CMOS technology and has balanced output drive. Take care to avoid bus contention because it can drive currents that would exceed maximum limits.

Because this design is for down-translating voltage, no pullup resistors are required.

9.2.2 Detailed Design Procedure

1. Recommended Input conditions
 - Specified high and low levels. See (V_{IH} and V_{IL}) in [Recommended Operating Conditions](#)
 - Inputs are overvoltage tolerant allowing them to go as high as 7 V at any valid V_{CC}
2. Recommend output conditions
 - Load currents should not exceed 128 mA on each channel

Typical Application (continued)

9.2.3 Application Curves

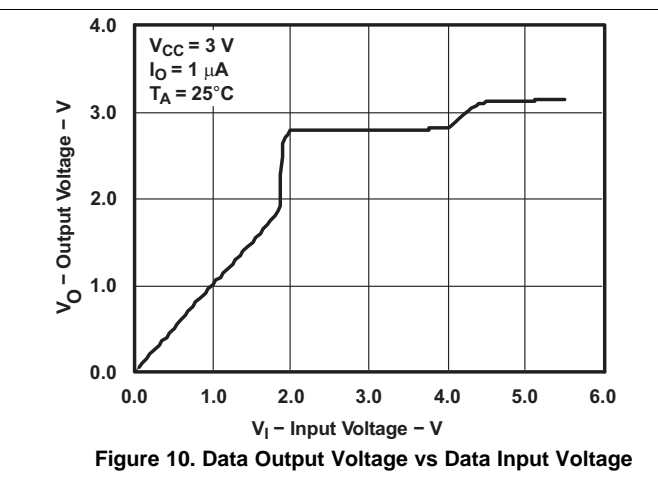
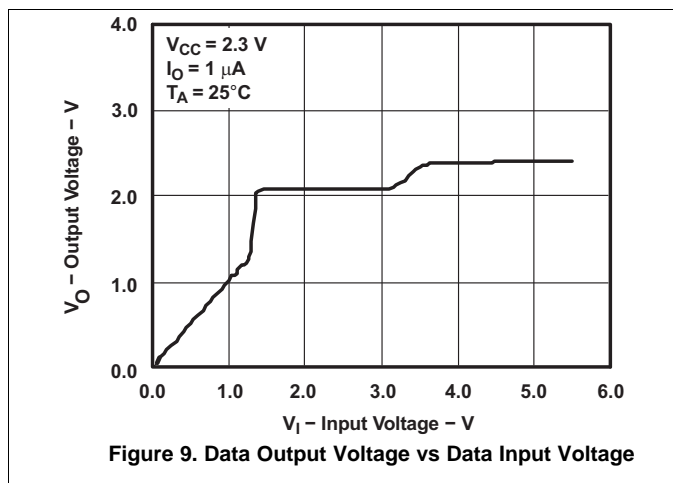

10 Power Supply Recommendations

The power supply can be any voltage between the minimum and maximum supply voltage rating located in the [Recommended Operating Conditions](#).

Each V_{CC} terminal should have a good bypass capacitor to prevent power disturbance. For devices with a single supply, a 0.1- μF bypass capacitor is recommended. If there are multiple pins labeled V_{CC} , then a 0.01- μF or 0.022- μF capacitor is recommended for each V_{CC} because the V_{CC} pins will be tied together internally. For devices with dual supply pins operating at different voltages, for example V_{CC} and V_{DD} , a 0.1- μF bypass capacitor is recommended for each supply pin. It is acceptable to parallel multiple bypass capacitors to reject different frequencies of noise. 0.1- μF and 1- μF capacitors are commonly used in parallel. The bypass capacitor should be installed as close to the power terminal as possible for best results.

11 Layout

11.1 Layout Guidelines

Reflections and matching are closely related to the loop antenna theory but are different enough to be discussed separately from the theory. When a PCB trace turns a corner at a 90° angle, a reflection can occur. A reflection occurs primarily because of the change of width of the trace. At the apex of the turn, the trace width increases to 1.414 times the width. This increase upsets the transmission-line characteristics, especially the distributed capacitance and self-inductance of the trace which results in the reflection. Not all PCB traces can be straight and therefore some traces must turn corners. [Figure 11](#) shows progressively better techniques of rounding corners. Only the last example (BEST) maintains constant trace width and minimizes reflections.

11.2 Layout Example

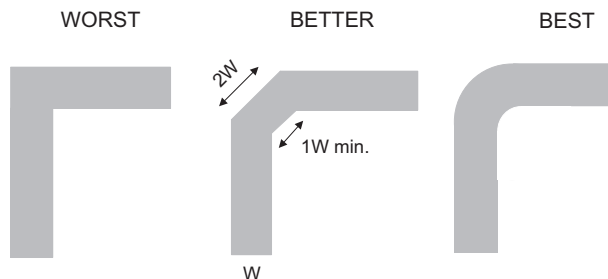

Figure 11. Trace Example

12 Device and Documentation Support

12.1 Documentation Support

12.1.1 Related Documentation

For related documentation see the following:

Implications of Slow or Floating CMOS Inputs, [SCBA004](#)

12.2 Receiving Notification of Documentation Updates

To receive notification of documentation updates, navigate to the device product folder on ti.com. In the upper right corner, click on Alert me to register and receive a weekly digest of any product information that has changed. For change details, review the revision history included in any revised document.

12.3 Community Resources

The following links connect to TI community resources. Linked contents are provided "AS IS" by the respective contributors. They do not constitute TI specifications and do not necessarily reflect TI's views; see TI's [Terms of Use](#).

TI E2E™ Online Community *TI's Engineer-to-Engineer (E2E) Community*. Created to foster collaboration among engineers. At e2e.ti.com, you can ask questions, share knowledge, explore ideas and help solve problems with fellow engineers.

Design Support *TI's Design Support* Quickly find helpful E2E forums along with design support tools and contact information for technical support.

12.4 Trademarks

E2E is a trademark of Texas Instruments.
All other trademarks are the property of their respective owners.

12.5 Electrostatic Discharge Caution



These devices have limited built-in ESD protection. The leads should be shorted together or the device placed in conductive foam during storage or handling to prevent electrostatic damage to the MOS gates.

12.6 Glossary

[SLYZ022](#) — *TI Glossary*.

This glossary lists and explains terms, acronyms, and definitions.

13 Mechanical, Packaging, and Orderable Information

The following pages include mechanical, packaging, and orderable information. This information is the most current data available for the designated devices. This data is subject to change without notice and revision of this document. For browser-based versions of this data sheet, refer to the left-hand navigation.

PACKAGING INFORMATION

Orderable Device	Status (1)	Package Type	Package Drawing	Pins	Package Qty	Eco Plan (2)	Lead finish/ Ball material (6)	MSL Peak Temp (3)	Op Temp (°C)	Device Marking (4/5)	Samples
SN74CB3T3245DBQR	ACTIVE	SSOP	DBQ	20	2500	RoHS & Green	NIPDAU	Level-2-260C-1 YEAR	-40 to 85	CB3T3245	Samples
SN74CB3T3245DGVR	ACTIVE	TVSOP	DGV	20	2000	RoHS & Green	NIPDAU	Level-1-260C-UNLIM	-40 to 85	KS245	Samples
SN74CB3T3245DW	ACTIVE	SOIC	DW	20	25	RoHS & Green	NIPDAU	Level-1-260C-UNLIM	-40 to 85	CB3T3245	Samples
SN74CB3T3245DWG4	ACTIVE	SOIC	DW	20	25	RoHS & Green	NIPDAU	Level-1-260C-UNLIM	-40 to 85	CB3T3245	Samples
SN74CB3T3245DWR	ACTIVE	SOIC	DW	20	2000	RoHS & Green	NIPDAU	Level-1-260C-UNLIM	-40 to 85	CB3T3245	Samples
SN74CB3T3245PW	LIFEBUY	TSSOP	PW	20	70	RoHS & Green	NIPDAU	Level-1-260C-UNLIM	-40 to 85	KS245	
SN74CB3T3245PWG4	LIFEBUY	TSSOP	PW	20	70	RoHS & Green	NIPDAU	Level-1-260C-UNLIM	-40 to 85	KS245	
SN74CB3T3245PWR	ACTIVE	TSSOP	PW	20	2000	RoHS & Green	NIPDAU	Level-1-260C-UNLIM	-40 to 85	KS245	Samples

(1) The marketing status values are defined as follows:

ACTIVE: Product device recommended for new designs.

LIFEBUY: TI has announced that the device will be discontinued, and a lifetime-buy period is in effect.

NRND: Not recommended for new designs. Device is in production to support existing customers, but TI does not recommend using this part in a new design.

PREVIEW: Device has been announced but is not in production. Samples may or may not be available.

OBSELETE: TI has discontinued the production of the device.

(2) **RoHS:** TI defines "RoHS" to mean semiconductor products that are compliant with the current EU RoHS requirements for all 10 RoHS substances, including the requirement that RoHS substance do not exceed 0.1% by weight in homogeneous materials. Where designed to be soldered at high temperatures, "RoHS" products are suitable for use in specified lead-free processes. TI may reference these types of products as "Pb-Free".

RoHS Exempt: TI defines "RoHS Exempt" to mean products that contain lead but are compliant with EU RoHS pursuant to a specific EU RoHS exemption.

Green: TI defines "Green" to mean the content of Chlorine (Cl) and Bromine (Br) based flame retardants meet JS709B low halogen requirements of <=1000ppm threshold. Antimony trioxide based flame retardants must also meet the <=1000ppm threshold requirement.

(3) MSL, Peak Temp. - The Moisture Sensitivity Level rating according to the JEDEC industry standard classifications, and peak solder temperature.

(4) There may be additional marking, which relates to the logo, the lot trace code information, or the environmental category on the device.

(5) Multiple Device Markings will be inside parentheses. Only one Device Marking contained in parentheses and separated by a "-" will appear on a device. If a line is indented then it is a continuation of the previous line and the two combined represent the entire Device Marking for that device.

⁽⁶⁾ Lead finish/Ball material - Orderable Devices may have multiple material finish options. Finish options are separated by a vertical ruled line. Lead finish/Ball material values may wrap to two lines if the finish value exceeds the maximum column width.

Important Information and Disclaimer:The information provided on this page represents TI's knowledge and belief as of the date that it is provided. TI bases its knowledge and belief on information provided by third parties, and makes no representation or warranty as to the accuracy of such information. Efforts are underway to better integrate information from third parties. TI has taken and continues to take reasonable steps to provide representative and accurate information but may not have conducted destructive testing or chemical analysis on incoming materials and chemicals. TI and TI suppliers consider certain information to be proprietary, and thus CAS numbers and other limited information may not be available for release.

In no event shall TI's liability arising out of such information exceed the total purchase price of the TI part(s) at issue in this document sold by TI to Customer on an annual basis.

TAPE AND REEL INFORMATION

QUADRANT ASSIGNMENTS FOR PIN 1 ORIENTATION IN TAPE

*All dimensions are nominal

Device	Package Type	Package Drawing	Pins	SPQ	Reel Diameter (mm)	Reel Width W1 (mm)	A0 (mm)	B0 (mm)	K0 (mm)	P1 (mm)	W (mm)	Pin1 Quadrant
SN74CB3T3245DBQR	SSOP	DBQ	20	2500	330.0	16.4	6.5	9.0	2.1	8.0	16.0	Q1
SN74CB3T3245DGVR	TVSOP	DGV	20	2000	330.0	12.4	6.9	5.6	1.6	8.0	12.0	Q1
SN74CB3T3245DWR	SOIC	DW	20	2000	330.0	24.4	10.8	13.3	2.7	12.0	24.0	Q1
SN74CB3T3245PWR	TSSOP	PW	20	2000	330.0	16.4	6.95	7.0	1.4	8.0	16.0	Q1

TAPE AND REEL BOX DIMENSIONS

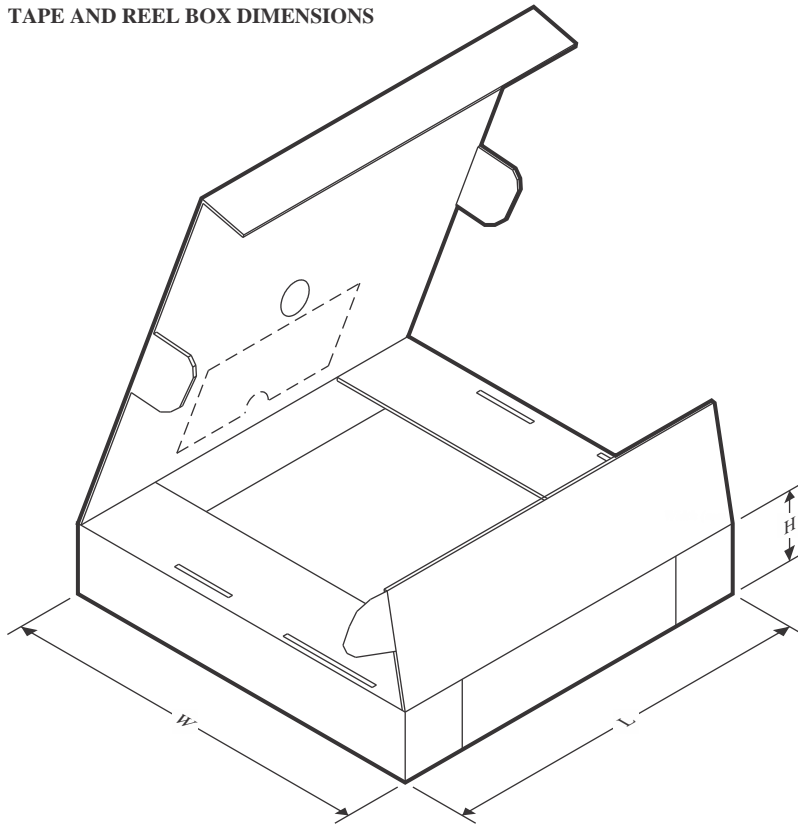

*All dimensions are nominal

Device	Package Type	Package Drawing	Pins	SPQ	Length (mm)	Width (mm)	Height (mm)
SN74CB3T3245DBQR	SSOP	DBQ	20	2500	356.0	356.0	35.0
SN74CB3T3245DGVR	TVSOP	DGV	20	2000	367.0	367.0	35.0
SN74CB3T3245DWR	SOIC	DW	20	2000	367.0	367.0	45.0
SN74CB3T3245PWR	TSSOP	PW	20	2000	356.0	356.0	35.0

TUBE

*All dimensions are nominal

Device	Package Name	Package Type	Pins	SPQ	L (mm)	W (mm)	T (μm)	B (mm)
SN74CB3T3245DW	DW	SOIC	20	25	507	12.83	5080	6.6
SN74CB3T3245DWG4	DW	SOIC	20	25	507	12.83	5080	6.6
SN74CB3T3245PW	PW	TSSOP	20	70	530	10.2	3600	3.5
SN74CB3T3245PWG4	PW	TSSOP	20	70	530	10.2	3600	3.5



4220206/A 02/2017

NOTES:

1. All linear dimensions are in millimeters. Any dimensions in parenthesis are for reference only. Dimensioning and tolerancing per ASME Y14.5M.
2. This drawing is subject to change without notice.
3. This dimension does not include mold flash, protrusions, or gate burrs. Mold flash, protrusions, or gate burrs shall not exceed 0.15 mm per side.
4. This dimension does not include interlead flash. Interlead flash shall not exceed 0.25 mm per side.
5. Reference JEDEC registration MO-153.

EXAMPLE BOARD LAYOUT

PW0020A

TSSOP - 1.2 mm max height

SMALL OUTLINE PACKAGE



LAND PATTERN EXAMPLE
EXPOSED METAL SHOWN
SCALE: 10X



SOLDER MASK DETAILS

4220206/A 02/2017

NOTES: (continued)

- 6. Publication IPC-7351 may have alternate designs.
- 7. Solder mask tolerances between and around signal pads can vary based on board fabrication site.

EXAMPLE STENCIL DESIGN

PW0020A

TSSOP - 1.2 mm max height

SMALL OUTLINE PACKAGE



SOLDER PASTE EXAMPLE
BASED ON 0.125 mm THICK STENCIL
SCALE: 10X

4220206/A 02/2017

NOTES: (continued)

8. Laser cutting apertures with trapezoidal walls and rounded corners may offer better paste release. IPC-7525 may have alternate design recommendations.
9. Board assembly site may have different recommendations for stencil design.

PW (R-PDSO-G20)

PLASTIC SMALL OUTLINE



- NOTES:
- A. All linear dimensions are in millimeters.
 - B. This drawing is subject to change without notice.
 - C. Publication IPC-7351 is recommended for alternate design.
 - D. Laser cutting apertures with trapezoidal walls and also rounding corners will offer better paste release. Customers should contact their board assembly site for stencil design recommendations. Refer to IPC-7525 for other stencil recommendations.
 - E. Customers should contact their board fabrication site for solder mask tolerances between and around signal pads.

DBQ (R-PDSO-G20)

PLASTIC SMALL-OUTLINE PACKAGE

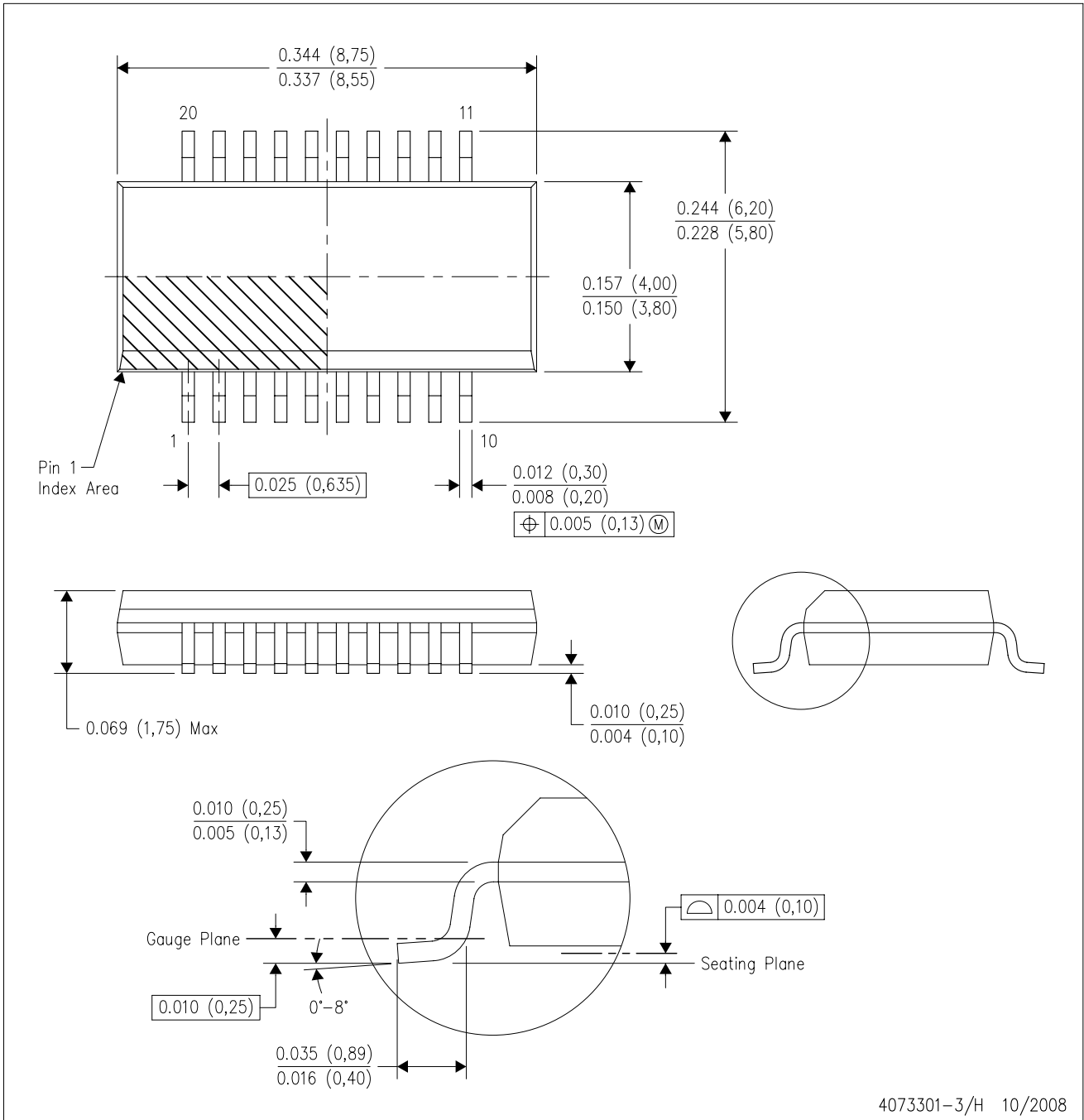

- NOTES:
- A. All linear dimensions are in inches (millimeters).
 - B. This drawing is subject to change without notice.
 - C. Body dimensions do not include mold flash or protrusion not to exceed 0.006 (0,15) per side.
 - D. Falls within JEDEC MO-137 variation AD.

DGV (R-PDSO-G**)

PLASTIC SMALL-OUTLINE

24 PINS SHOWN



- NOTES: A. All linear dimensions are in millimeters.
 B. This drawing is subject to change without notice.
 C. Body dimensions do not include mold flash or protrusion, not to exceed 0,15 per side.
 D. Falls within JEDEC: 24/48 Pins – MO-153
 14/16/20/56 Pins – MO-194

DW0020A



PACKAGE OUTLINE

SOIC - 2.65 mm max height

SOIC



4220724/A 05/2016

NOTES:

1. All linear dimensions are in millimeters. Dimensions in parenthesis are for reference only. Dimensioning and tolerancing per ASME Y14.5M.
2. This drawing is subject to change without notice.
3. This dimension does not include mold flash, protrusions, or gate burrs. Mold flash, protrusions, or gate burrs shall not exceed 0.15 mm per side.
4. This dimension does not include interlead flash. Interlead flash shall not exceed 0.43 mm per side.
5. Reference JEDEC registration MS-013.

EXAMPLE BOARD LAYOUT

DW0020A

SOIC - 2.65 mm max height

SOIC



LAND PATTERN EXAMPLE
SCALE:6X



SOLDER MASK DETAILS

4220724/A 05/2016

NOTES: (continued)

- 6. Publication IPC-7351 may have alternate designs.
- 7. Solder mask tolerances between and around signal pads can vary based on board fabrication site.

EXAMPLE STENCIL DESIGN

DW0020A

SOIC - 2.65 mm max height

SOIC



SOLDER PASTE EXAMPLE
BASED ON 0.125 mm THICK STENCIL
SCALE:6X

4220724/A 05/2016

NOTES: (continued)

8. Laser cutting apertures with trapezoidal walls and rounded corners may offer better paste release. IPC-7525 may have alternate design recommendations.
9. Board assembly site may have different recommendations for stencil design.

IMPORTANT NOTICE AND DISCLAIMER

TI PROVIDES TECHNICAL AND RELIABILITY DATA (INCLUDING DATA SHEETS), DESIGN RESOURCES (INCLUDING REFERENCE DESIGNS), APPLICATION OR OTHER DESIGN ADVICE, WEB TOOLS, SAFETY INFORMATION, AND OTHER RESOURCES "AS IS" AND WITH ALL FAULTS, AND DISCLAIMS ALL WARRANTIES, EXPRESS AND IMPLIED, INCLUDING WITHOUT LIMITATION ANY IMPLIED WARRANTIES OF MERCHANTABILITY, FITNESS FOR A PARTICULAR PURPOSE OR NON-INFRINGEMENT OF THIRD PARTY INTELLECTUAL PROPERTY RIGHTS.

These resources are intended for skilled developers designing with TI products. You are solely responsible for (1) selecting the appropriate TI products for your application, (2) designing, validating and testing your application, and (3) ensuring your application meets applicable standards, and any other safety, security, regulatory or other requirements.

These resources are subject to change without notice. TI grants you permission to use these resources only for development of an application that uses the TI products described in the resource. Other reproduction and display of these resources is prohibited. No license is granted to any other TI intellectual property right or to any third party intellectual property right. TI disclaims responsibility for, and you will fully indemnify TI and its representatives against, any claims, damages, costs, losses, and liabilities arising out of your use of these resources.

TI's products are provided subject to [TI's Terms of Sale](#) or other applicable terms available either on [ti.com](https://www.ti.com) or provided in conjunction with such TI products. TI's provision of these resources does not expand or otherwise alter TI's applicable warranties or warranty disclaimers for TI products.

TI objects to and rejects any additional or different terms you may have proposed.

Mailing Address: Texas Instruments, Post Office Box 655303, Dallas, Texas 75265
Copyright © 2024, Texas Instruments Incorporated

Looking for pricing, stock, or lifecycle information?

Click below to explore more details on WIN SOURCE:

 [View SN74CB3T3245DBQR on WIN SOURCE](#)

 [Texas Instruments](#) Information

Optimize Your Supply Chain with WIN SOURCE Solutions

-  Global Sourcing Solution
-  Obsolete Management
-  Cost Control Management
-  Shortage Management
-  Alternative Solution
-  Excess Inventory Management