



**THE DATASHEET OF
SN74AVC8T245PW**



SN74AVC8T245 8-Bit Dual-Supply Bus Transceiver With Configurable Voltage Translation and 3-State Outputs

1 Features

- Latch-Up Performance Exceeds 100 mA Per JESD 78, Class II
- ESD Protection Exceeds JESD 22
 - 8000-V Human-Body Model (A114-A)
 - 200-V Machine Model (A115-A)
 - 1000-V Charged-Device Model (C101)
- Control Inputs V_{IH}/V_{IL} Levels Are Referenced to V_{CCA} Voltage
- V_{CC} Isolation Feature – If Either V_{CC} Input Is at GND, All I/O Ports Are in the High-Impedance State
- I_{off} Supports Partial Power-Down Mode Operation
- Fully Configurable Dual-Rail Design Allows Each Port to Operate Over the Full 1.4-V to 3.6-V Power-Supply Range
- I/Os Are 4.6-V Tolerant
- Maximum Data Rates
 - 170 Mbps ($V_{CCA} < 1.8$ V or $V_{CCB} < 1.8$ V)
 - 320 Mbps ($V_{CCA} \geq 1.8$ V and $V_{CCB} \geq 1.8$ V)

2 Applications

- Personal Electronic
- Industrial
- Enterprise
- Telecom

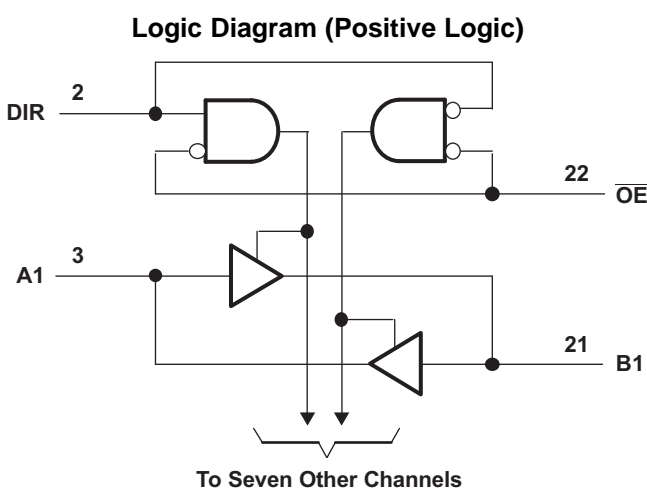

3 Description

This 8-bit noninverting bus transceiver uses two separate configurable power-supply rails. The SN74AVC8T245 is optimized to operate with V_{CCA}/V_{CCB} set at 1.4 V to 3.6 V. The device is operational with V_{CCA}/V_{CCB} as low as 1.2 V. The A port is designed to track V_{CCA} . V_{CCA} accepts any supply voltage from 1.2 V to 3.6 V. The B port is designed to track V_{CCB} . V_{CCB} accepts any supply voltage from 1.2 V to 3.6 V. This allows for universal low-voltage bidirectional translation between any of the 1.2-V, 1.5-V, 1.8-V, 2.5-V, and 3.3-V voltage nodes.

The SN74AVC8T245 is designed for asynchronous communication between data buses. The device transmits data from the A bus to the B bus or from the B bus to the A bus, depending on the logic level at the direction-control (DIR) input. The output-enable (\overline{OE}) input can be used to disable the outputs so the buses are effectively isolated.

The SN74AVC8T245 is designed so that the control pins (DIR and \overline{OE}) are supplied by V_{CCA} .

The SN74AVC8T245 solution is compatible with a single-supply system and can be replaced later with a '245 function, with minimal printed circuit board redesign.

This device is fully specified for partial-power-down applications using I_{off} . The I_{off} circuitry disables the outputs, thus preventing damaging current backflow through the device when it is powered down.

The V_{CC} isolation feature ensures that if either V_{CC} input is at GND, both ports are in the high-impedance state.

To ensure the high-impedance state during power up or power down, \overline{OE} shall be tied to V_{CC} through a pullup resistor; the minimum value of the resistor is determined by the current-sinking capability of the driver.

Device Information⁽¹⁾

PART NUMBER	PACKAGE	BODY SIZE (NOM)
SN74AVC8T245	VQFN (24)	3.50 mm x 5.50 mm
	TSSOP (24)	4.40 mm x 7.80 mm
	TVSOP (24)	4.40 mm x 5.00 mm

(1) For all available packages, see the orderable addendum at the end of the datasheet.



Table of Contents

1 Features	1	8.1 Overview	15
2 Applications	1	8.2 Functional Block Diagram	15
3 Description	1	8.3 Feature Description	15
4 Revision History	2	8.4 Device Functional Modes	15
5 Pin Configuration and Functions	3	9 Application and Implementation	16
6 Specifications	4	9.1 Application Information	16
6.1 Absolute Maximum Ratings	4	9.2 Typical Application	16
6.2 ESD Ratings	4	10 Power Supply Recommendations	18
6.3 Recommended Operating Conditions	5	11 Layout	19
6.4 Thermal Information	5	11.1 Layout Guidelines	19
6.5 Electrical Characteristics	6	11.2 Layout Example	19
6.6 Switching Characteristics, $V_{CCA} = 1.2\text{ V}$	7	12 Device and Documentation Support	20
6.7 Switching Characteristics, $V_{CCA} = 1.5\text{ V} \pm 0.1\text{ V}$	7	12.1 Documentation Support	20
6.8 Switching Characteristics, $V_{CCA} = 1.8\text{ V} \pm 0.15\text{ V}$	8	12.2 Receiving Notification of Documentation Updates	20
6.9 Switching Characteristics, $V_{CCA} = 2.5\text{ V} \pm 0.2\text{ V}$	9	12.3 Community Resources	20
6.10 Switching Characteristics, $V_{CCA} = 3.3\text{ V} \pm 0.3\text{ V}$	10	12.4 Trademarks	20
6.11 Operating Characteristics	11	12.5 Electrostatic Discharge Caution	20
6.12 Typical Characteristics	12	12.6 Glossary	20
7 Parameter Measurement Information	14	13 Mechanical, Packaging, and Orderable Information	20
8 Detailed Description	15		

4 Revision History

NOTE: Page numbers for previous revisions may differ from page numbers in the current version.

Changes from Revision I (December 2014) to Revision J	Page
• Changed MAX value for Operating free-air temperature, T_A from: 85°C to: 125°C	5
• Added values for $T_A = -40^\circ\text{C}$ to $+125^\circ\text{C}$ in <i>Electrical Characteristics</i> and all <i>Switching Characteristics</i> tables	6
• Added <i>Documentation Support</i> section, <i>Receiving Notification of Documentation Updates</i> , and <i>Community Resources</i> section	20

Changes from Revision H (February 2007) to Revision I	Page
• Added <i>Pin Configuration and Functions</i> section, <i>ESD Rating</i> table, <i>Feature Description</i> section, <i>Device Functional Modes</i> , <i>Application and Implementation</i> section, <i>Power Supply Recommendations</i> section, <i>Layout</i> section, <i>Device and Documentation Support</i> section, and <i>Mechanical, Packaging, and Orderable Information</i> section	1

5 Pin Configuration and Functions

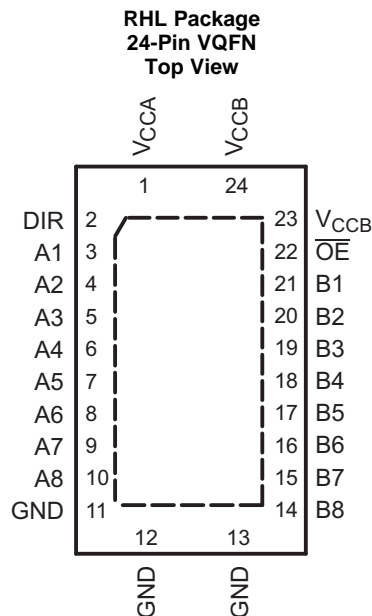
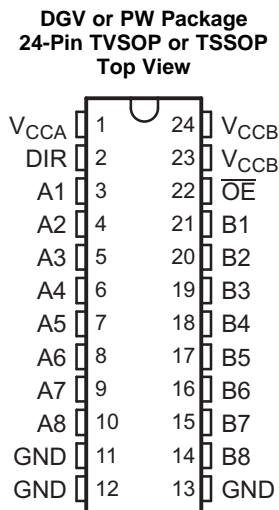

Pin Functions

PIN		I/O	DESCRIPTION
NAME	NO.		
A1	3	I/O	Input/output A1. Referenced to V _{CCA} .
A2	4	I/O	Input/output A2. Referenced to V _{CCA} .
A3	5	I/O	Input/output A3. Referenced to V _{CCA} .
A4	6	I/O	Input/output A4. Referenced to V _{CCA} .
A5	7	I/O	Input/output A5. Referenced to V _{CCA} .
A6	8	I/O	Input/output A6. Referenced to V _{CCA} .
A7	9	I/O	Input/output A7. Referenced to V _{CCA} .
A8	10	I/O	Input/output A8. Referenced to V _{CCA} .
B1	21	I/O	Input/output B1. Referenced to V _{CCB} .
B2	20	I/O	Input/output B2. Referenced to V _{CCB} .
B3	19	I/O	Input/output B3. Referenced to V _{CCB} .
B4	18	I/O	Input/output B4. Referenced to V _{CCB} .
B5	17	I/O	Input/output B5. Referenced to V _{CCB} .
B6	16	I/O	Input/output B6. Referenced to V _{CCB} .
B7	15	I/O	Input/output B7. Referenced to V _{CCB} .
B8	14	I/O	Input/output B8. Referenced to V _{CCB} .
DIR	2	I	Direction-control signal
GND	11, 12, 13	—	Ground
OE	22	I	3-state output-mode enables. Pull OE high to place all outputs in 3-state mode. Referenced to V _{CCA} .
V _{CCA}	1	—	A-port supply voltage. 1.2 V ≤ V _{CCA} ≤ 3.6 V
V _{CCB}	23, 24	—	B-port supply voltage. 1.2 V ≤ V _{CCB} ≤ 3.6 V

6 Specifications

6.1 Absolute Maximum Ratings

 over operating free-air temperature range (unless otherwise noted) ⁽¹⁾

		MIN	MAX	UNIT	
V_{CCA}, V_{CCB}	Supply voltage	-0.5	4.6	V	
V_I	Input voltage ⁽²⁾	I/O ports (A port)	-0.5	4.6	V
		I/O ports (B port)	-0.5	4.6	
		Control inputs	-0.5	4.6	
V_O	Voltage range applied to any output in the high-impedance or power-off state ⁽²⁾	A port	-0.5	4.6	V
		B port	-0.5	4.6	
V_O	Voltage range applied to any output in the high or low state ^{(2) (3)}	A port	-0.5	$V_{CCA} + 0.5$	V
		B port	-0.5	$V_{CCB} + 0.5$	
I_{IK}	Input clamp current	$V_I < 0$	-50	mA	
I_{OK}	Output clamp current	$V_O < 0$	-50	mA	
I_O	Continuous output current	-50	50	mA	
	Continuous current through $V_{CCA}, V_{CCB},$ or GND	-100	100	mA	
T_{stg}	Storage temperature	-65	150	°C	

- (1) Stresses beyond those listed under Absolute Maximum Ratings may cause permanent damage to the device. These are stress ratings only, and functional operation of the device at these or any other conditions beyond those indicated under *Recommended Operating Conditions* is not implied. Exposure to absolute-maximum-rated conditions for extended periods may affect device reliability.
- (2) The input voltage and output negative-voltage ratings may be exceeded if the input and output current ratings are observed.
- (3) The output positive-voltage rating may be exceeded up to 4.6 V maximum if the output current rating is observed.

6.2 ESD Ratings

		VALUE	UNIT
$V_{(ESD)}$	Electrostatic discharge	Human-body model (HBM), per ANSI/ESDA/JEDEC JS-001 ⁽¹⁾	±8000
		Charged-device model (CDM), per JEDEC specification JESD22-C101 ⁽²⁾	±1000
		Machine model (MM)	±200

- (1) JEDEC document JEP155 states that 500-V HBM allows safe manufacturing with a standard ESD control process.
- (2) JEDEC document JEP157 states that 250-V CDM allows safe manufacturing with a standard ESD control process.

6.3 Recommended Operating Conditions

 See ⁽¹⁾⁽²⁾⁽³⁾

		V_{CCI}	V_{CCO}	MIN	MAX	UNIT
V_{CCA}	Supply voltage			1.2	3.6	V
V_{CCB}	Supply voltage			1.2	3.6	V
V_{IH}	High-level input voltage	Data inputs	1.2 V to 1.95 V	$V_{CCI} \times 0.65$		V
			1.95 V to 2.7 V	1.6		
			2.7 V to 3.6 V	2		
V_{IL}	Low-level input voltage	Data inputs	1.2 V to 1.95 V	$V_{CCI} \times 0.35$		V
			1.95 V to 2.7 V	0.7		
			2.7 V to 3.6 V	0.8		
V_{IH}	High-level input voltage	DIR (referenced to V_{CCA})	1.2 V to 1.95 V	$V_{CCA} \times 0.65$		V
			1.95 V to 2.7 V	1.6		
			2.7 V to 3.6 V	2		
V_{IL}	Low-level input voltage	DIR (referenced to V_{CCA})	1.2 V to 1.95 V	$V_{CCA} \times 0.35$		V
			1.95 V to 2.7 V	0.7		
			2.7 V to 3.6 V	0.8		
V_I	Input voltage			0	3.6	V
V_O	Output voltage	Active state		0	V_{CCO}	V
		3-state		0	3.6	
I_{OH}	High-level output current		1.2 V		-3	mA
			1.4 V to 1.6 V		-6	
			1.65 V to 1.95 V		-8	
			2.3 V to 2.7 V		-9	
			3 V to 3.6 V		-12	
I_{OL}	Low-level output current		1.2 V		3	mA
			1.4 V to 1.6 V		6	
			1.65 V to 1.95 V		8	
			2.3 V to 2.7 V		9	
			3 V to 3.6 V		12	
$\Delta t/\Delta v$	Input transition rise or fall rate				5	ns/V
T_A	Operating free-air temperature			-40	125	°C

 (1) V_{CCI} is the V_{CC} associated with the input port.

 (2) V_{CCO} is the V_{CC} associated with the output port.

 (3) All unused data inputs of the device must be held at V_{CCI} or GND to ensure proper device operation. See [Implications of Slow or Floating CMOS Inputs](#), SCBA004.

6.4 Thermal Information

THERMAL METRIC ⁽¹⁾		SN74AVC8T245			UNIT
		DGV	PW	RHL	
		24 PINS	24 PINS	24 PINS	
$R_{\theta JA}$	Junction-to-ambient thermal resistance	95.5	92	35	°C/W
$R_{\theta JC(top)}$	Junction-to-case (top) thermal resistance	27	29.3	39.9	°C/W
$R_{\theta JB}$	Junction-to-board thermal resistance	48.9	46.7	13.8	°C/W
Ψ_{JT}	Junction-to-top characterization parameter	0.7	1.5	0.3	°C/W
Ψ_{JB}	Junction-to-board characterization parameter	48.5	46.2	13.8	°C/W
$R_{\theta JC(bot)}$	Junction-to-case (bottom) thermal resistance	N/A	N/A	1.4	°C/W

 (1) For more information about traditional and new thermal metrics, see the [Semiconductor and IC Package Thermal Metrics](#) application report.

6.5 Electrical Characteristics

 over recommended operating free-air temperature range (unless otherwise noted)⁽¹⁾⁽²⁾

PARAMETER	TEST CONDITIONS	V _{CCA}	V _{CCB}	T _A = 25°C			–40°C to +85°C		–40°C to +125°C		UNIT
				MIN	TYP	MAX	MIN	MAX	MIN	MAX	
V _{OH}	I _{OH} = –100 μA	V _I = V _{IH}	1.2 V to 3.6 V	1.2 V to 3.6 V				V _{CCO} – 0.2	V _{CCO} – 0.2	V	
	I _{OH} = –3 mA		1.2 V	1.2 V	0.95						
	I _{OH} = –6 mA		1.4 V	1.4 V		1.05	1				
	I _{OH} = –8 mA		1.65 V	1.65 V		1.2	1.2				
	I _{OH} = –9 mA		2.3 V	2.3 V		1.75	1.75				
	I _{OH} = –12 mA		3 V	3 V		2.3	2.3				
V _{OL}	I _{OL} = 100 μA	V _I = V _{IL}	1.2 V to 3.6 V	1.2 V to 3.6 V				0.2	0.2	V	
	I _{OL} = 3 mA		1.2 V	1.2 V	0.15						
	I _{OL} = 6 mA		1.4 V	1.4 V		0.35	0.35				
	I _{OL} = 8 mA		1.65 V	1.65 V		0.45	0.45				
	I _{OL} = 9 mA		2.3 V	2.3 V		0.55	0.55				
	I _{OL} = 12 mA		3 V	3 V		0.7	0.7				
I _I Control inputs	V _I = V _{CCA} or GND	1.2 V to 3.6 V	1.2 V to 3.6 V	–0.25	±0.025	0.25	–1	1	±1	μA	
I _{off} A or B port	V _I or V _O = 0 to 3.6 V	0 V	0 V to 3.6 V	–1	±0.1	1	–5	5	±5	μA	
		0 V to 3.6 V	0 V	–1	±0.1	1	–5	5	±5		
I _{OZ} ⁽³⁾ A or B port	V _O = V _{CCO} or GND, V _I = V _{CCI} or GND, OE = V _{IH}	3.6 V	3.6 V		±0.5	±2.5		±5	±5	μA	
I _{CCA}	V _I = V _{CCI} or GND, I _O = 0	1.2 V to 3.6 V	1.2 V to 3.6 V					15	15	μA	
		0 V	3.6 V					–2	–2		
		3.6 V	0 V					15	15		
I _{CCB}	V _I = V _{CCI} or GND, I _O = 0	1.2 V to 3.6 V	1.2 V to 3.6 V					15	15	μA	
		0 V	3.6 V					15	15		
		3.6 V	0 V					–2	–2		
I _{CCA} + I _{CCB}	V _I = V _{CCI} or GND, I _O = 0	1.2 V to 3.6 V	1.2 V to 3.6 V					25	25	μA	
C _i Control inputs	V _I = 3.3 V or GND	3.3 V	3.3 V		3.5			4.5		pF	
C _{io} A or B port	V _O = 3.3 V or GND	3.3 V	3.3 V		6			7		pF	

- (1) V_{CCO} is the V_{CC} associated with the output port.
- (2) V_{CCI} is the V_{CC} associated with the input port.
- (3) For I/O ports, the parameter I_{OZ} includes the input leakage current.

6.6 Switching Characteristics, $V_{CCA} = 1.2\text{ V}$

over recommended operating free-air temperature range, $V_{CCA} = 1.2\text{ V}$ (see [Figure 10](#))

PARAMETER	FROM (INPUT)	TO (OUTPUT)	V_{CCB}	$T_A = -40^\circ\text{C to } +85^\circ\text{C}$		$T_A = -40^\circ\text{C to } +125^\circ\text{C}$		UNIT
				TYP		TYP		
t_{PLH}, t_{PHL}	A	B	$V_{CCB} = 1.2\text{ V}$	3.1		3.1		ns
			$V_{CCB} = 1.5\text{ V}$	2.6		2.6		
			$V_{CCB} = 1.8\text{ V}$	2.5		2.5		
			$V_{CCB} = 2.5\text{ V}$	3		3		
			$V_{CCB} = 3.3\text{ V}$	3.5		3.5		
t_{PLH}, t_{PHL}	B	A	$V_{CCB} = 1.2\text{ V}$	3.1		3.1		ns
			$V_{CCB} = 1.5\text{ V}$	2.7		2.7		
			$V_{CCB} = 1.8\text{ V}$	2.5		2.5		
			$V_{CCB} = 2.5\text{ V}$	2.4		2.4		
			$V_{CCB} = 3.3\text{ V}$	2.3		2.3		
t_{PZH}, t_{PZL}	\overline{OE}	A	$V_{CCB} = 1.2\text{ V}$	5.3		5.3		ns
			$V_{CCB} = 1.5\text{ V}$					
			$V_{CCB} = 1.8\text{ V}$					
			$V_{CCB} = 2.5\text{ V}$					
			$V_{CCB} = 3.3\text{ V}$					
t_{PZH}, t_{PZL}	\overline{OE}	B	$V_{CCB} = 1.2\text{ V}$	5.1		5.1		ns
			$V_{CCB} = 1.5\text{ V}$	4		4		
			$V_{CCB} = 1.8\text{ V}$	3.5		3.5		
			$V_{CCB} = 2.5\text{ V}$	3.2		3.2		
			$V_{CCB} = 3.3\text{ V}$	3.1		3.1		
t_{PHZ}, t_{PLZ}	\overline{OE}	A	$V_{CCB} = 1.2\text{ V}$	4.8		4.8		ns
			$V_{CCB} = 1.5\text{ V}$					
			$V_{CCB} = 1.8\text{ V}$					
			$V_{CCB} = 2.5\text{ V}$					
			$V_{CCB} = 3.3\text{ V}$					
t_{PHZ}, t_{PLZ}	\overline{OE}	B	$V_{CCB} = 1.2\text{ V}$	4.7		4.7		ns
			$V_{CCB} = 1.5\text{ V}$	4		4		
			$V_{CCB} = 1.8\text{ V}$	4.1		4.1		
			$V_{CCB} = 2.5\text{ V}$	4.3		4.3		
			$V_{CCB} = 3.3\text{ V}$	5.1		5.1		

6.7 Switching Characteristics, $V_{CCA} = 1.5\text{ V} \pm 0.1\text{ V}$

over recommended operating free-air temperature range, $V_{CCA} = 1.5\text{ V} \pm 0.1\text{ V}$ (see [Figure 10](#))

PARAMETER	FROM (INPUT)	TO (OUTPUT)	V_{CCB}	$T_A = -40^\circ\text{C to } +85^\circ\text{C}$			$T_A = -40^\circ\text{C to } +125^\circ\text{C}$			UNIT
				MIN	TYP	MAX	MIN	TYP	MAX	
t_{PLH}, t_{PHL}	A	B	$V_{CCB} = 1.2\text{ V}$	2.7			3.1			ns
			$V_{CCB} = 1.5\text{ V} \pm 0.1\text{ V}$	0.5		5.4	0.5		14.7	
			$V_{CCB} = 1.8\text{ V} \pm 0.15\text{ V}$	0.5		4.6	0.5		13.3	
			$V_{CCB} = 2.5\text{ V} \pm 0.2\text{ V}$	0.5		4.9	0.5		13.9	
			$V_{CCB} = 3.3\text{ V} \pm 0.3\text{ V}$	0.5		6.8	0.5		17.2	
t_{PLH}, t_{PHL}	B	A	$V_{CCB} = 1.2\text{ V}$	2.6			3.1			ns
			$V_{CCB} = 1.5\text{ V} \pm 0.1\text{ V}$	0.5		5.4	0.5		14.7	
			$V_{CCB} = 1.8\text{ V} \pm 0.15\text{ V}$	0.5		5.1	0.5		14.2	
			$V_{CCB} = 2.5\text{ V} \pm 0.2\text{ V}$	0.5		4.7	0.5		13.5	
			$V_{CCB} = 3.3\text{ V} \pm 0.3\text{ V}$	0.5		4.5	0.5		13.2	

Switching Characteristics, $V_{CCA} = 1.5\text{ V} \pm 0.1\text{ V}$ (continued)

 over recommended operating free-air temperature range, $V_{CCA} = 1.5\text{ V} \pm 0.1\text{ V}$ (see [Figure 10](#))

PARAMETER	FROM (INPUT)	TO (OUTPUT)	V_{CCB}	$T_A = -40^\circ\text{C to } +85^\circ\text{C}$			$T_A = -40^\circ\text{C to } +125^\circ\text{C}$			UNIT
				MIN	TYP	MAX	MIN	TYP	MAX	
t_{PZH}, t_{PZL}	$\overline{\text{OE}}$	A	$V_{CCB} = 1.2\text{ V}$	3.7			5.3			ns
			$V_{CCB} = 1.5\text{ V} \pm 0.1\text{ V}$	1.1		8.7	0.5		20.5	
			$V_{CCB} = 1.8\text{ V} \pm 0.15\text{ V}$	1.1		8.7	0.5		20.5	
			$V_{CCB} = 2.5\text{ V} \pm 0.2\text{ V}$	1.1		8.7	0.5		20.5	
			$V_{CCB} = 3.3\text{ V} \pm 0.3\text{ V}$	1.1		8.7	0.5		20.5	
t_{PZH}, t_{PZL}	$\overline{\text{OE}}$	B	$V_{CCB} = 1.2\text{ V}$	4.8			5.1			ns
			$V_{CCB} = 1.5\text{ V} \pm 0.1\text{ V}$	1.1		7.6	0.5		18.6	
			$V_{CCB} = 1.8\text{ V} \pm 0.15\text{ V}$	1.1		7.1	0.5		17.7	
			$V_{CCB} = 2.5\text{ V} \pm 0.2\text{ V}$	1		5.6	0.5		15.1	
			$V_{CCB} = 3.3\text{ V} \pm 0.3\text{ V}$	1		5.2	0.5		14.4	
t_{PHZ}, t_{PLZ}	$\overline{\text{OE}}$	A	$V_{CCB} = 1.2\text{ V}$	3.1			4.8			ns
			$V_{CCB} = 1.5\text{ V} \pm 0.1\text{ V}$	0.5		8.6	0.5		20.3	
			$V_{CCB} = 1.8\text{ V} \pm 0.15\text{ V}$	0.5		8.6	0.5		20.3	
			$V_{CCB} = 2.5\text{ V} \pm 0.2\text{ V}$	0.5		8.6	0.5		20.3	
			$V_{CCB} = 3.3\text{ V} \pm 0.3\text{ V}$	0.5		8.6	0.5		20.3	
t_{PHZ}, t_{PLZ}	$\overline{\text{OE}}$	B	$V_{CCB} = 1.2\text{ V}$	4.1			4.7			ns
			$V_{CCB} = 1.5\text{ V} \pm 0.1\text{ V}$	0.5		8.4	0.5		20	
			$V_{CCB} = 1.8\text{ V} \pm 0.15\text{ V}$	0.5		7.6	0.5		18.6	
			$V_{CCB} = 2.5\text{ V} \pm 0.2\text{ V}$	0.5		7.2	0.5		17.9	
			$V_{CCB} = 3.3\text{ V} \pm 0.3\text{ V}$	0.5		7.8	0.5		18.9	

6.8 Switching Characteristics, $V_{CCA} = 1.8\text{ V} \pm 0.15\text{ V}$

 over recommended operating free-air temperature range, $V_{CCA} = 1.8\text{ V} \pm 0.15\text{ V}$ (see [Figure 10](#))

PARAMETER	FROM (INPUT)	TO (OUTPUT)	V_{CCB}	$T_A = -40^\circ\text{C to } +85^\circ\text{C}$			$T_A = -40^\circ\text{C to } +125^\circ\text{C}$			UNIT
				MIN	TYP	MAX	MIN	TYP	MAX	
t_{PLH}, t_{PHL}	A	B	$V_{CCB} = 1.2\text{ V}$	2.5			2.5			ns
			$V_{CCB} = 1.5\text{ V} \pm 0.1\text{ V}$	0.5		5.1	0.5		14.2	
			$V_{CCB} = 1.8\text{ V} \pm 0.15\text{ V}$	0.5		4.4	0.5		13	
			$V_{CCB} = 2.5\text{ V} \pm 0.2\text{ V}$	0.5		4	0.5		12.3	
			$V_{CCB} = 3.3\text{ V} \pm 0.3\text{ V}$	0.5		3.9	0.5		12.1	
t_{PLH}, t_{PHL}	B	A	$V_{CCB} = 1.2\text{ V}$	2.5			2.5			ns
			$V_{CCB} = 1.5\text{ V} \pm 0.1\text{ V}$	0.5		4.6	0.5		13.3	
			$V_{CCB} = 1.8\text{ V} \pm 0.15\text{ V}$	0.5		4.4	0.5		13	
			$V_{CCB} = 2.5\text{ V} \pm 0.2\text{ V}$	0.5		3.9	0.5		12.1	
			$V_{CCB} = 3.3\text{ V} \pm 0.3\text{ V}$	0.5		3.7	0.5		11.8	
t_{PZH}, t_{PZL}	$\overline{\text{OE}}$	A	$V_{CCB} = 1.2\text{ V}$	3			3			ns
			$V_{CCB} = 1.5\text{ V} \pm 0.1\text{ V}$	1		6.8	0.5		17.2	
			$V_{CCB} = 1.8\text{ V} \pm 0.15\text{ V}$	1		6.8	0.5		17.2	
			$V_{CCB} = 2.5\text{ V} \pm 0.2\text{ V}$	1		6.8	0.5		17.2	
			$V_{CCB} = 3.3\text{ V} \pm 0.3\text{ V}$	1		6.8	0.5		17.2	

Switching Characteristics, $V_{CCA} = 1.8\text{ V} \pm 0.15\text{ V}$ (continued)

over recommended operating free-air temperature range, $V_{CCA} = 1.8\text{ V} \pm 0.15\text{ V}$ (see [Figure 10](#))

PARAMETER	FROM (INPUT)	TO (OUTPUT)	V_{CCB}	$T_A = -40^\circ\text{C to } +85^\circ\text{C}$			$T_A = -40^\circ\text{C to } +125^\circ\text{C}$			UNIT
				MIN	TYP	MAX	MIN	TYP	MAX	
t_{PZH}, t_{PZL}	$\overline{\text{OE}}$	B	$V_{CCB} = 1.2\text{ V}$	4.6			4.6			ns
			$V_{CCB} = 1.5\text{ V} \pm 0.1\text{ V}$	1.1		8.2	0.5		19.6	
			$V_{CCB} = 1.8\text{ V} \pm 0.15\text{ V}$	1		6.7	0.5		17	
			$V_{CCB} = 2.5\text{ V} \pm 0.2\text{ V}$	0.5		5.1	0.5		14.2	
			$V_{CCB} = 3.3\text{ V} \pm 0.3\text{ V}$	0.5		4.5	0.5		13.2	
t_{PHZ}, t_{PLZ}	$\overline{\text{OE}}$	A	$V_{CCB} = 1.2\text{ V}$	2.8			2.8			ns
			$V_{CCB} = 1.5\text{ V} \pm 0.1\text{ V}$	0.5		7.1	0.5		17.7	
			$V_{CCB} = 1.8\text{ V} \pm 0.15\text{ V}$	0.5		7.1	0.5		17.7	
			$V_{CCB} = 2.5\text{ V} \pm 0.2\text{ V}$	0.5		7.1	0.5		17.7	
			$V_{CCB} = 3.3\text{ V} \pm 0.3\text{ V}$	0.5		7.1	0.5		17.7	
t_{PHZ}, t_{PLZ}	$\overline{\text{OE}}$	B	$V_{CCB} = 1.2\text{ V}$	3.9			3.9			ns
			$V_{CCB} = 1.5\text{ V} \pm 0.1\text{ V}$	0.5		7.8	0.5		18.9	
			$V_{CCB} = 1.8\text{ V} \pm 0.15\text{ V}$	0.5		6.9	0.5		17.3	
			$V_{CCB} = 2.5\text{ V} \pm 0.2\text{ V}$	0.5		6	0.5		15.8	
			$V_{CCB} = 3.3\text{ V} \pm 0.3\text{ V}$	0.5		5.8	0.5		15.4	

6.9 Switching Characteristics, $V_{CCA} = 2.5\text{ V} \pm 0.2\text{ V}$

over recommended operating free-air temperature range, $V_{CCA} = 2.5\text{ V} \pm 0.2\text{ V}$ (see [Figure 10](#))

PARAMETER	FROM (INPUT)	TO (OUTPUT)	V_{CCB}	$T_A = -40^\circ\text{C to } +85^\circ\text{C}$			$T_A = -40^\circ\text{C to } +125^\circ\text{C}$			UNIT
				MIN	TYP	MAX	MIN	TYP	MAX	
t_{PLH}, t_{PHL}	A	B	$V_{CCB} = 1.2\text{ V}$	2.4			2.4			ns
			$V_{CCB} = 1.5\text{ V} \pm 0.1\text{ V}$	0.5		4.7	0.5		13.5	
			$V_{CCB} = 1.8\text{ V} \pm 0.15\text{ V}$	0.5		3.9	0.5		12.1	
			$V_{CCB} = 2.5\text{ V} \pm 0.2\text{ V}$	0.5		3.1	0.5		10.7	
			$V_{CCB} = 3.3\text{ V} \pm 0.3\text{ V}$	0.5		2.8	0.5		10.2	
t_{PLH}, t_{PHL}	B	A	$V_{CCB} = 1.2\text{ V}$	3			3			ns
			$V_{CCB} = 1.5\text{ V} \pm 0.1\text{ V}$	0.5		4.9	0.5		13.9	
			$V_{CCB} = 1.8\text{ V} \pm 0.15\text{ V}$	0.5		4	0.5		12.3	
			$V_{CCB} = 2.5\text{ V} \pm 0.2\text{ V}$	0.5		3.1	0.5		10.7	
			$V_{CCB} = 3.3\text{ V} \pm 0.3\text{ V}$	0.5		2.9	0.5		10.4	
t_{PZH}, t_{PZL}	$\overline{\text{OE}}$	A	$V_{CCB} = 1.2\text{ V}$	2.2			2.2			ns
			$V_{CCB} = 1.5\text{ V} \pm 0.1\text{ V}$	0.5		4.8	0.5		13.7	
			$V_{CCB} = 1.8\text{ V} \pm 0.15\text{ V}$	0.5		4.8	0.5		13.7	
			$V_{CCB} = 2.5\text{ V} \pm 0.2\text{ V}$	0.5		4.8	0.5		13.7	
			$V_{CCB} = 3.3\text{ V} \pm 0.3\text{ V}$	0.5		4.8	0.5		13.7	
t_{PZH}, t_{PZL}	$\overline{\text{OE}}$	B	$V_{CCB} = 1.2\text{ V}$	4.5			4.5			ns
			$V_{CCB} = 1.5\text{ V} \pm 0.1\text{ V}$	1.1		7.9	0.5		19.1	
			$V_{CCB} = 1.8\text{ V} \pm 0.15\text{ V}$	0.5		6.4	0.5		16.5	
			$V_{CCB} = 2.5\text{ V} \pm 0.2\text{ V}$	0.5		4.6	0.5		13.3	
			$V_{CCB} = 3.3\text{ V} \pm 0.3\text{ V}$	0.5		4	0.5		12.3	

Switching Characteristics, $V_{CCA} = 2.5\text{ V} \pm 0.2\text{ V}$ (continued)

 over recommended operating free-air temperature range, $V_{CCA} = 2.5\text{ V} \pm 0.2\text{ V}$ (see Figure 10)

PARAMETER	FROM (INPUT)	TO (OUTPUT)	V_{CCB}	$T_A = -40^\circ\text{C to } +85^\circ\text{C}$			$T_A = -40^\circ\text{C to } +125^\circ\text{C}$			UNIT
				MIN	TYP	MAX	MIN	TYP	MAX	
t_{PHZ}, t_{PLZ}	\overline{OE}	A	$V_{CCB} = 1.2\text{ V}$	1.8			1.8			ns
			$V_{CCB} = 1.5\text{ V} \pm 0.1\text{ V}$	0.5		5.1	0.5		14.2	
			$V_{CCB} = 1.8\text{ V} \pm 0.15\text{ V}$	0.5		5.1	0.5		14.2	
			$V_{CCB} = 2.5\text{ V} \pm 0.2\text{ V}$	0.5		5.1	0.5		14.2	
			$V_{CCB} = 3.3\text{ V} \pm 0.3\text{ V}$	0.5		5.1	0.5		14.2	
t_{PHZ}, t_{PLZ}	\overline{OE}	B	$V_{CCB} = 1.2\text{ V}$	3.6			3.6			ns
			$V_{CCB} = 1.5\text{ V} \pm 0.1\text{ V}$	0.5		7.1	0.5		17.7	
			$V_{CCB} = 1.8\text{ V} \pm 0.15\text{ V}$	0.5		6.3	0.5		16.3	
			$V_{CCB} = 2.5\text{ V} \pm 0.2\text{ V}$	0.5		5.1	0.5		14.2	
			$V_{CCB} = 3.3\text{ V} \pm 0.3\text{ V}$	0.5		3.9	0.5		12.1	

6.10 Switching Characteristics, $V_{CCA} = 3.3\text{ V} \pm 0.3\text{ V}$

 over recommended operating free-air temperature range, $V_{CCA} = 3.3\text{ V} \pm 0.3\text{ V}$ (see Figure 10)

PARAMETER	FROM (INPUT)	TO (OUTPUT)	V_{CCB}	$T_A = -40^\circ\text{C to } +85^\circ\text{C}$			$T_A = -40^\circ\text{C to } +125^\circ\text{C}$			UNIT	
				MIN	TYP	MAX	MIN	TYP	MAX		
t_{PLH}, t_{PHL}	A	B	$V_{CCB} = 1.2\text{ V}$	2.3			2.3			ns	
			$V_{CCB} = 1.5\text{ V} \pm 0.1\text{ V}$	0.5		4.5	0.5		13.2		
			$V_{CCB} = 1.8\text{ V} \pm 0.15\text{ V}$	t_{PLH}	0.5		3.7	0.5			11.1
				t_{PHL}	0.5		3.3	0.5			11.1
			$V_{CCB} = 2.5\text{ V} \pm 0.2\text{ V}$	0.5		2.9	0.5		10.4		
$V_{CCB} = 3.3\text{ V} \pm 0.3\text{ V}$	0.5		2.5	0.5		9.7					
t_{PLH}, t_{PHL}	B	A	$V_{CCB} = 1.2\text{ V}$	3.5			3.5			ns	
			$V_{CCB} = 1.5\text{ V} \pm 0.1\text{ V}$	0.5		6.8	0.5		17.2		
			$V_{CCB} = 1.8\text{ V} \pm 0.15\text{ V}$	0.5		3.9	0.5		12.1		
			$V_{CCB} = 2.5\text{ V} \pm 0.2\text{ V}$	0.5		2.8	0.5		10.2		
			$V_{CCB} = 3.3\text{ V} \pm 0.3\text{ V}$	0.5		2.5	0.5		9.7		
t_{PZH}, t_{PZL}	\overline{OE}	A	$V_{CCB} = 1.2\text{ V}$	2			2			ns	
			$V_{CCB} = 1.5\text{ V} \pm 0.1\text{ V}$	0.5		4	0.5		12.3		
			$V_{CCB} = 1.8\text{ V} \pm 0.15\text{ V}$	0.5		4	0.5		12.3		
			$V_{CCB} = 2.5\text{ V} \pm 0.2\text{ V}$	0.5		4	0.5		12.3		
			$V_{CCB} = 3.3\text{ V} \pm 0.3\text{ V}$	0.5		4	0.5		12.3		
t_{PZH}, t_{PZL}	\overline{OE}	B	$V_{CCB} = 1.2\text{ V}$	4.5			4.5			ns	
			$V_{CCB} = 1.5\text{ V} \pm 0.1\text{ V}$	1.1		7.8	0.5		18.9		
			$V_{CCB} = 1.8\text{ V} \pm 0.15\text{ V}$	0.5		6.2	0.5		16.1		
			$V_{CCB} = 2.5\text{ V} \pm 0.2\text{ V}$	0.5		4.5	0.5		13.2		
			$V_{CCB} = 3.3\text{ V} \pm 0.3\text{ V}$	0.5		3.9	0.5		12.3		
t_{PHZ}, t_{PLZ}	\overline{OE}	A	$V_{CCB} = 1.2\text{ V}$	1.7			1.7			ns	
			$V_{CCB} = 1.5\text{ V} \pm 0.1\text{ V}$	0.5		4	0.5		12.3		
			$V_{CCB} = 1.8\text{ V} \pm 0.15\text{ V}$	0.5		4	0.5		12.3		
			$V_{CCB} = 2.5\text{ V} \pm 0.2\text{ V}$	0.5		4	0.5		12.3		
			$V_{CCB} = 3.3\text{ V} \pm 0.3\text{ V}$	0.5		4	0.5		12.3		

Switching Characteristics, $V_{CCA} = 3.3\text{ V} \pm 0.3\text{ V}$ (continued)

 over recommended operating free-air temperature range, $V_{CCA} = 3.3\text{ V} \pm 0.3\text{ V}$ (see [Figure 10](#))

PARAMETER	FROM (INPUT)	TO (OUTPUT)	V_{CCB}	$T_A = -40^\circ\text{C to } +85^\circ\text{C}$			$T_A = -40^\circ\text{C to } +125^\circ\text{C}$			UNIT
				MIN	TYP	MAX	MIN	TYP	MAX	
t_{PHZ}, t_{PLZ}	\overline{OE}	B	$V_{CCB} = 1.2\text{ V}$	3.4			3.4			ns
			$V_{CCB} = 1.5\text{ V} \pm 0.1\text{ V}$	0.5		6.9	0.5		17.4	
			$V_{CCB} = 1.8\text{ V} \pm 0.15\text{ V}$	0.5		6	0.5		15.8	
			$V_{CCB} = 2.5\text{ V} \pm 0.2\text{ V}$	0.5		4.8	0.5		13.7	
			$V_{CCB} = 3.3\text{ V} \pm 0.3\text{ V}$	0.5		4.2	0.5		12.6	

6.11 Operating Characteristics
 $T_A = 25^\circ\text{C}$

PARAMETER			TEST CONDITIONS	$V_{CCA} =$ $V_{CCB} = 1.2\text{ V}$	$V_{CCA} =$ $V_{CCB} = 1.5\text{ V}$	$V_{CCA} =$ $V_{CCB} = 1.8\text{ V}$	$V_{CCA} =$ $V_{CCB} = 2.5\text{ V}$	$V_{CCA} =$ $V_{CCB} = 3.3\text{ V}$	UNIT
				TYP	TYP	TYP	TYP	TYP	
$C_{pdA}^{(1)}$	A to B	Outputs enabled	$C_L = 0,$ $f = 10\text{ MHz},$ $t_r = t_f = 1\text{ ns}$	1	1	1	1	1	pF
		Outputs disabled		1	1	1	1	1	
	B to A	Outputs enabled		12	12	12	13	14	
		Outputs disabled		1	1	1	1	1	
$C_{pdB}^{(1)}$	A to B	Outputs enabled	$C_L = 0,$ $f = 10\text{ MHz},$ $t_r = t_f = 1\text{ ns}$	12	12	12	13	14	pF
		Outputs disabled		1	1	1	1	1	
	B to A	Outputs enabled		1	1	1	1	1	
		Outputs disabled		1	1	1	1	1	

(1) Power dissipation capacitance per transceiver

Table 1. Typical Total Static Power Consumption ($I_{CCA} + I_{CCB}$)

V_{CCB}	V_{CCA}						UNIT
	0 V	1.2 V	1.5 V	1.8 V	2.5 V	3.3 V	
0 V	0	<0.5	<0.5	<0.5	<0.5	<0.5	μA
1.2 V	<0.5	<1	<1	<1	<1	1	
1.5 V	<0.5	<1	<1	<1	<1	1	
1.8 V	<0.5	<1	<1	<1	<1	<1	
2.5 V	<0.5	1	<1	<1	<1	<1	
3.3 V	<0.5	1	<1	<1	<1	<1	

6.12 Typical Characteristics

T_A = 25°C

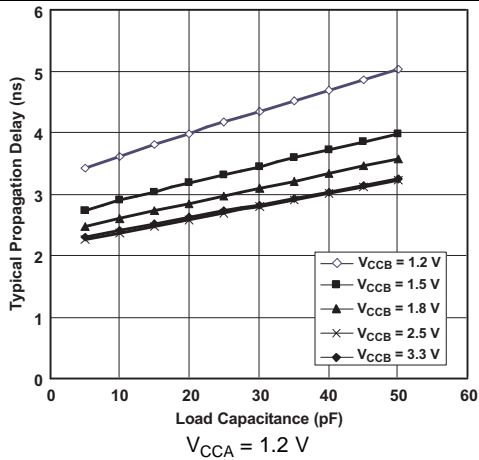

Figure 1. Typical Propagation Delay (A to B) vs Load Capacitance

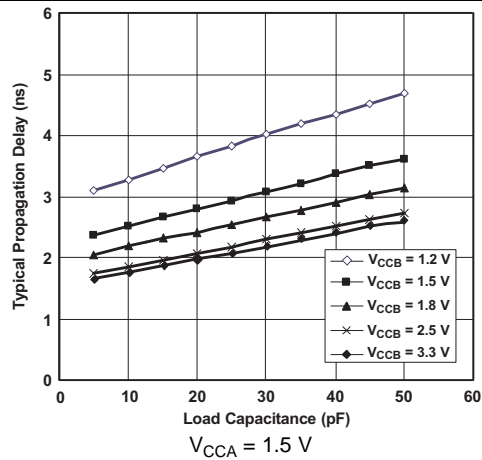

Figure 2. Typical Propagation Delay (A to B) vs Load Capacitance

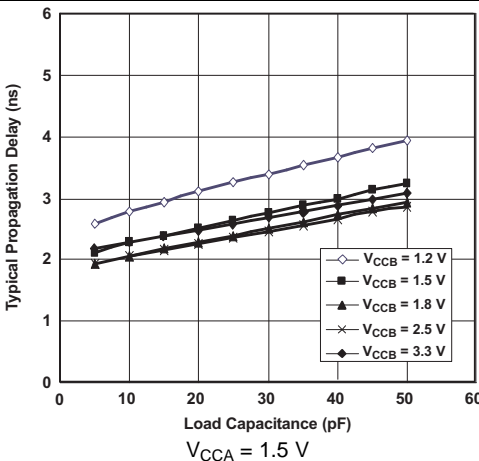

Figure 3. Typical Propagation Delay (A to B) vs Load Capacitance

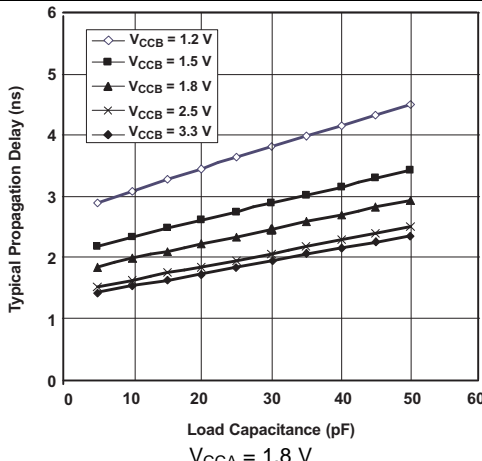

Figure 4. Typical Propagation Delay (A to B) vs Load Capacitance

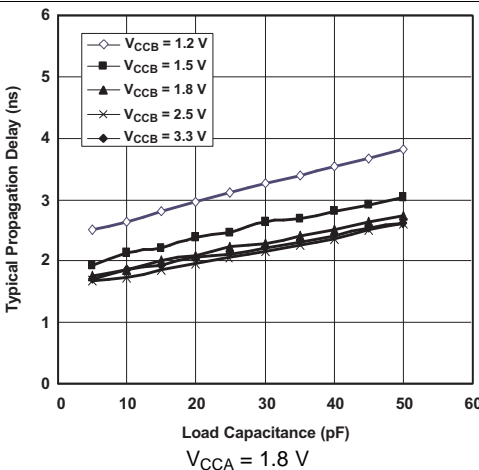

Figure 5. Typical Propagation Delay (A to B) vs Load Capacitance

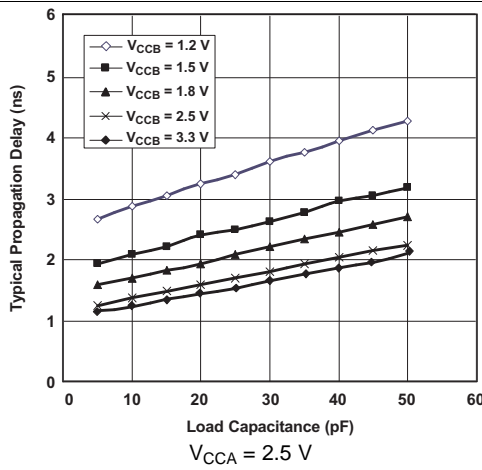

Figure 6. Typical Propagation Delay (A to B) vs Load Capacitance

Typical Characteristics (continued)

T_A = 25°C

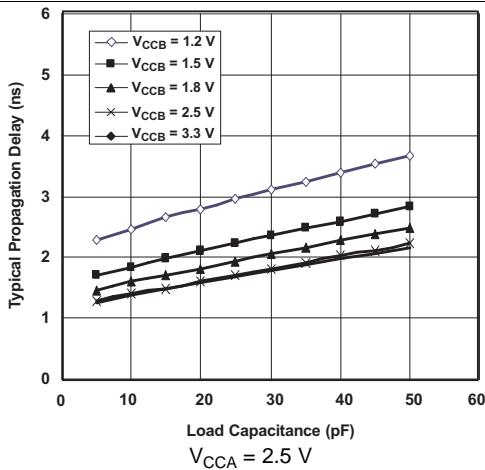

Figure 7. Typical Propagation Delay (A to B) vs Load Capacitance

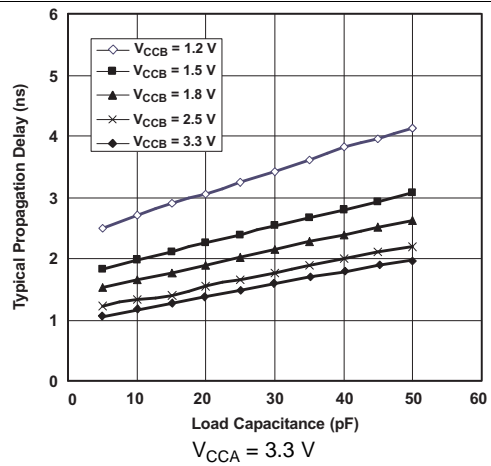

Figure 8. Typical Propagation Delay (A to B) vs Load Capacitance

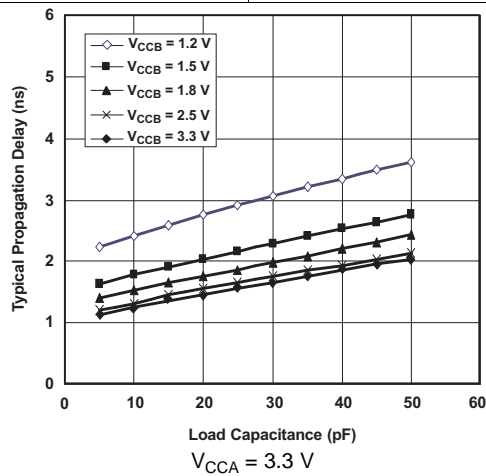
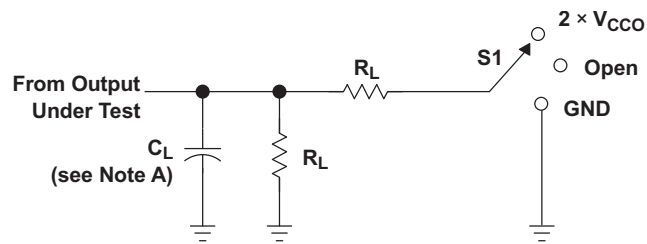

Figure 9. Typical Propagation Delay (A to B) vs Load Capacitance

7 Parameter Measurement Information

LOAD CIRCUIT

TEST	S1
t_{pd}	Open
t_{PLZ}/t_{PZL}	$2 \times V_{CCO}$
t_{PHZ}/t_{PZH}	GND

V_{CCO}	C_L	R_L	V_{TP}
1.2 V	15 pF	2 kW	0.1 V
1.5 V ± 0.1 V	15 pF	2 kW	0.1 V
1.8 V ± 0.15 V	15 pF	2 kW	0.15 V
2.5 V ± 0.2 V	15 pF	2 kW	0.15 V
3.3 V ± 0.3 V	15 pF	2 kW	0.3 V

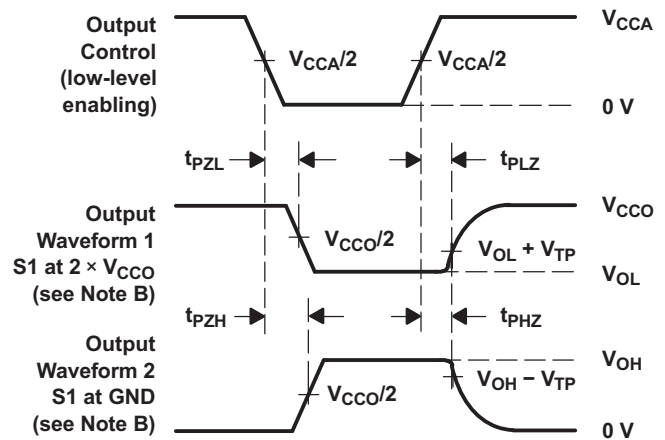
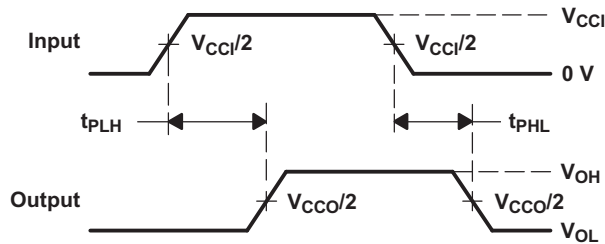
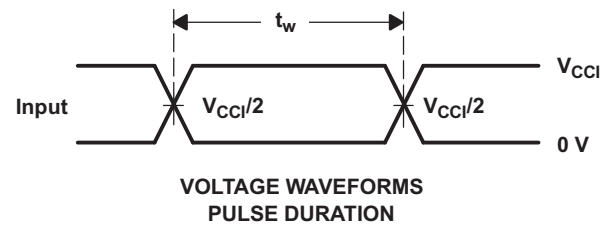

- NOTES:
- C_L includes probe and jig capacitance.
 - Waveform 1 is for an output with internal conditions such that the output is low except when disabled by the output control. Waveform 2 is for an output with internal conditions such that the output is high, except when disabled by the output control.
 - All input pulses are supplied by generators having the following characteristics: PRR = 10 MHz, $Z_O = 50 \Omega$, $dv/dt \geq 1 \text{ V/ns}$.
 - The outputs are measured one at a time, with one transition per measurement.
 - t_{PLZ} and t_{PHZ} are the same as t_{dis} .
 - t_{PZL} and t_{PZH} are the same as t_{en} .
 - t_{PLH} and t_{PHL} are the same as t_{pd} .
 - V_{CC1} is the V_{CC} associated with the input port.
 - V_{CCO} is the V_{CC} associated with the output port.

Figure 10. Load Circuit and Voltage Waveforms

8 Detailed Description

8.1 Overview

The SN74AVC8T245 is an 8-bit, dual-supply noninverting transceiver with bidirectional voltage level translation. Pins A and control pins (DIR and \overline{OE}) are supported by V_{CCA} and pins B are supported by V_{CCB} . The A port is able to accept I/O voltages ranging from 1.2 V to 3.6 V, while the B port can accept I/O voltages from 1.2 V to 3.6 V. A high on DIR allows data transmission from A to B and a low on DIR allows data transmission from B to A when \overline{OE} is set to low. When \overline{OE} is set to high, both A and B are in the high-impedance state.

8.2 Functional Block Diagram

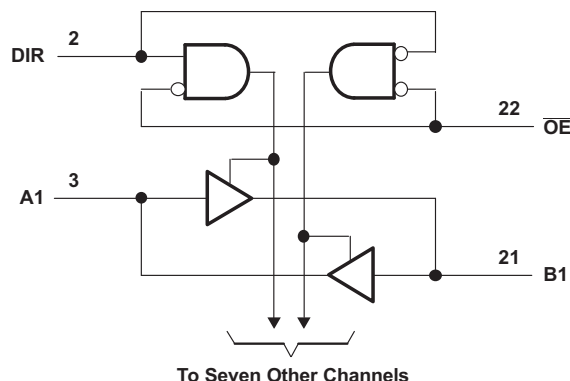

8.3 Feature Description

8.3.1 Fully Configurable Dual-Rail Design Allows Each Port to Operate Over the Full 1.2-V to 3.6-V Power-Supply Range

Both V_{CCA} and V_{CCB} can be supplied at any voltage between 1.2 V and 3.6 V making the device suitable for translating between any of the low voltage nodes (1.2 V, 1.8 V, 2.5 V, and 3.3 V).

8.3.2 Support High-Speed Translation

SN74AVC8T245 can support high data rate application. The translated signal data rate can be up to 320 Mbps when the device power supply is more than 1.8 V.

8.3.3 I_{off} Supports Partial-Power-Down Mode Operation

I_{off} prevents backflow current by disabling I/O output circuits when device is in partial power-down mode.

8.4 Device Functional Modes

The SN74AVC8T245 is a voltage level transceiver that can operate from 1.2 V to 3.6 V (V_{CCA}) and 1.2 V to 3.6 V (V_{CCB}). The signal translation between 1.2 V and 3.6 V requires direction control and output enable control. When \overline{OE} is low and DIR is high, data transmission is from A to B. When \overline{OE} is low and DIR is low, data transmission is from B to A. When \overline{OE} is high, both output ports will be high-impedance.

Table 2. Function Table (Each 8-Bit Section)

INPUTS		OPERATION
\overline{OE}	DIR	
L	L	B data to A bus
L	H	A data to B bus
H	X	All outputs Hi-Z

9 Application and Implementation

NOTE

Information in the following applications sections is not part of the TI component specification, and TI does not warrant its accuracy or completeness. TI's customers are responsible for determining suitability of components for their purposes. Customers should validate and test their design implementation to confirm system functionality.

9.1 Application Information

The SN74AVC8T245 device can be used in level-translation applications for interfacing devices or systems operating at different interface voltages with one another. The SN74AVC8T245 device is ideal for data transmission which direction is different with each channel. The maximum data rate can be up to 320 Mbps when device voltage power supply is more than 1.8 V.

9.2 Typical Application

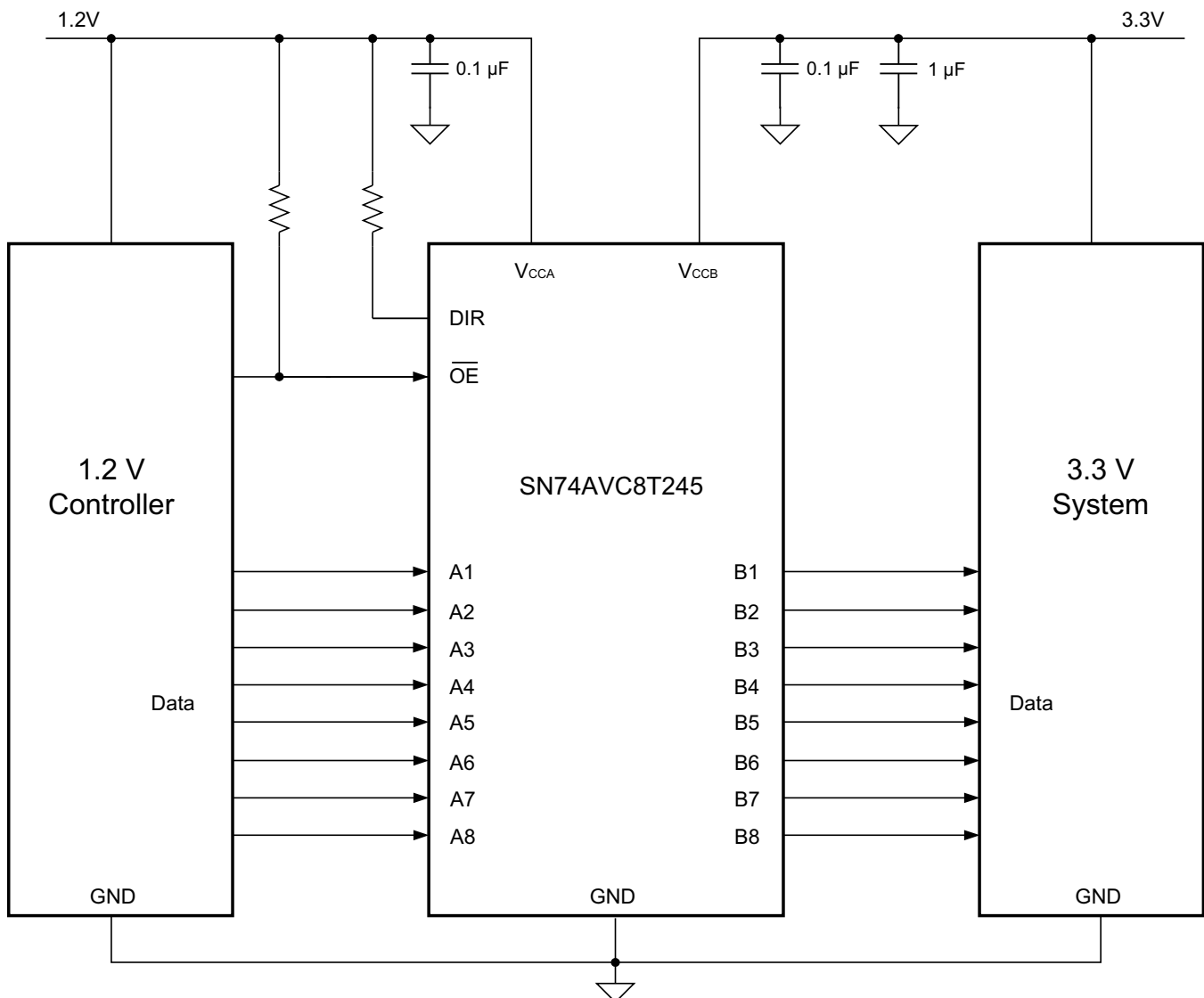

Figure 11. Typical Application Schematic

Typical Application (continued)

9.2.1 Design Requirements

For this design example, use the parameters listed in [Table 3](#).

Table 3. Design Parameters

DESIGN PARAMETERS	EXAMPLE VALUE
Input voltage range	1.2 V to 3.6 V
Output voltage range	1.2 V to 3.6 V

9.2.2 Detailed Design Procedure

To begin the design process, determine the following:

- Input voltage range
 - Use the supply voltage of the device that is driving the SN74AVC8T245 device to determine the input voltage range. For a valid logic high the value must exceed the V_{IH} of the input port. For a valid logic low the value must be less than the V_{IL} of the input port.
- Output voltage range
 - Use the supply voltage of the device that the SN74AVC8T245 device is driving to determine the output voltage range.

9.2.3 Application Curve

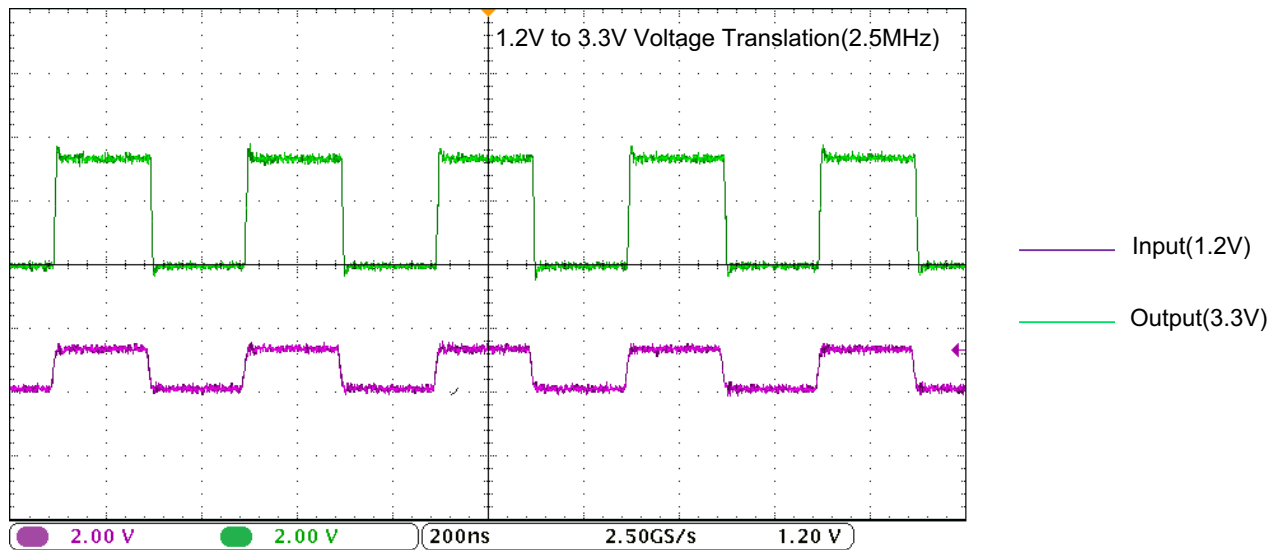

Figure 12. Translation Up (1.2 V to 3.3 V) at 2.5 MHz

10 Power Supply Recommendations

The SN74AVC8T245 device uses two separate configurable power-supply rails, V_{CCA} and V_{CCB} . V_{CCA} accepts any supply voltage from 1.2 V to 3.6 V and V_{CCB} accepts any supply voltage from 1.2 V to 3.6 V. The A port and B port are designed to track V_{CCA} and V_{CCB} , respectively, allowing for low-voltage bidirectional translation between any of the 1.2-V, 1.5-V, 1.8-V, 2.5-V and 3.3-V voltage nodes.

The output-enable \overline{OE} input circuit is designed so that it is supplied by V_{CCA} and when the \overline{OE} input is high, all outputs are placed in the high-impedance state. To ensure the high-impedance state of the outputs during power up or power down, the \overline{OE} input pin must be tied to V_{CCA} through a pullup resistor and must not be enabled until V_{CCA} and V_{CCB} are fully ramped and stable. The minimum value of the pullup resistor to V_{CCA} is determined by the current-sinking capability of the driver.

11 Layout

11.1 Layout Guidelines

To ensure reliability of the device, following common printed-circuit board layout guidelines is recommended.

- Bypass capacitors should be used on power supplies.
- Short trace lengths should be used to avoid excessive loading.
- Placing pads on the signal paths for loading capacitors or pullup resistors to help adjust rise and fall times of signals depending on the system requirements.

11.2 Layout Example

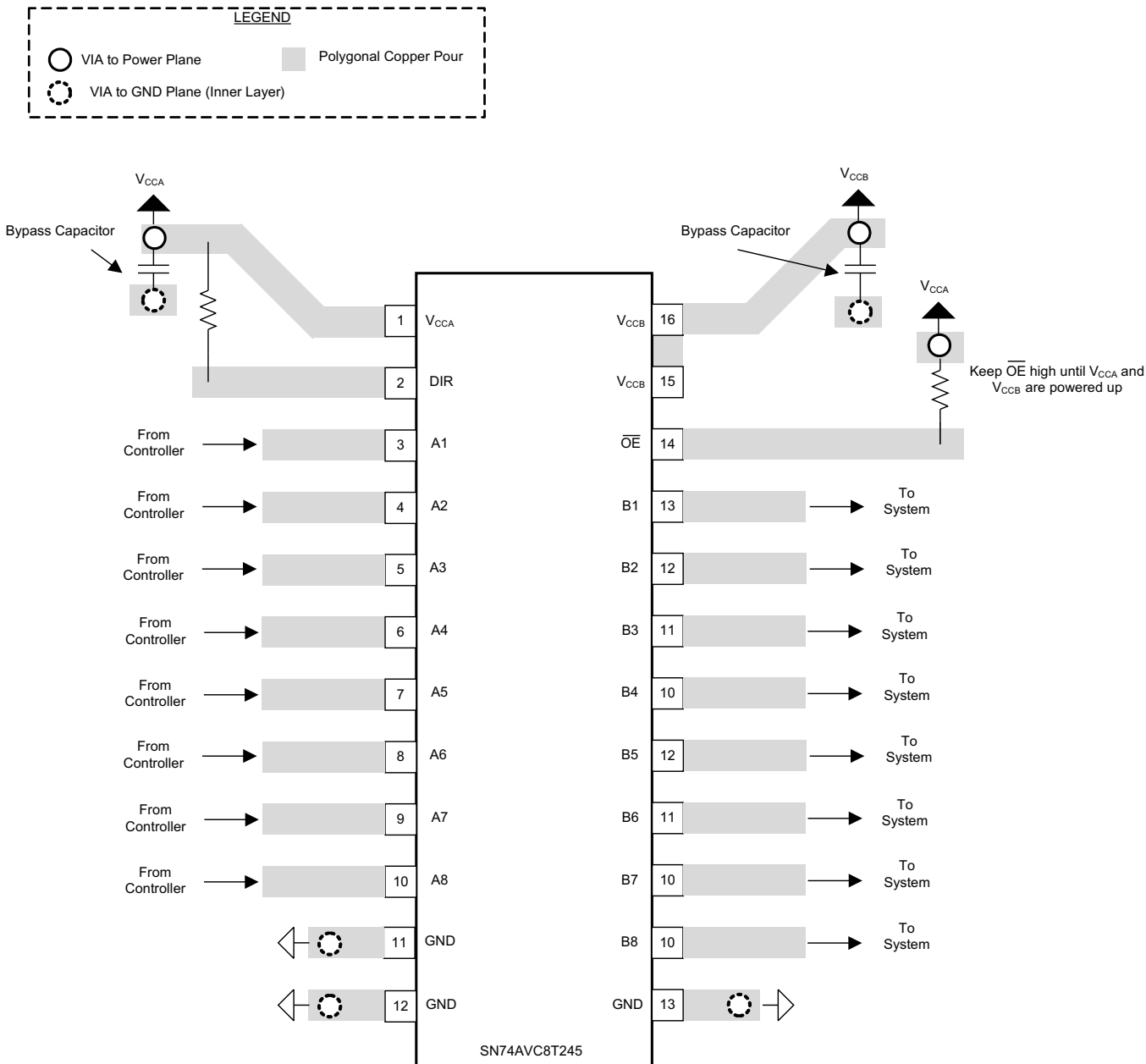

12 Device and Documentation Support

12.1 Documentation Support

12.1.1 Related Documentation

For related documentation see the following:

[Implications of Slow or Floating CMOS Inputs](#), SCBA004

12.2 Receiving Notification of Documentation Updates

To receive notification of documentation updates, navigate to the device product folder on ti.com. In the upper right corner, click on *Alert me* to register and receive a weekly digest of any product information that has changed. For change details, review the revision history included in any revised document.

12.3 Community Resources

The following links connect to TI community resources. Linked contents are provided "AS IS" by the respective contributors. They do not constitute TI specifications and do not necessarily reflect TI's views; see TI's [Terms of Use](#).

TI E2E™ Online Community *TI's Engineer-to-Engineer (E2E) Community*. Created to foster collaboration among engineers. At e2e.ti.com, you can ask questions, share knowledge, explore ideas and help solve problems with fellow engineers.

Design Support *TI's Design Support* Quickly find helpful E2E forums along with design support tools and contact information for technical support.

12.4 Trademarks

E2E is a trademark of Texas Instruments.
All other trademarks are the property of their respective owners.

12.5 Electrostatic Discharge Caution



These devices have limited built-in ESD protection. The leads should be shorted together or the device placed in conductive foam during storage or handling to prevent electrostatic damage to the MOS gates.

12.6 Glossary

[SLYZ022](#) — *TI Glossary*.

This glossary lists and explains terms, acronyms, and definitions.

13 Mechanical, Packaging, and Orderable Information

The following pages include mechanical, packaging, and orderable information. This information is the most current data available for the designated devices. This data is subject to change without notice and revision of this document. For browser-based versions of this data sheet, refer to the left-hand navigation.

PACKAGING INFORMATION

Orderable Device	Status (1)	Package Type	Package Drawing	Pins	Package Qty	Eco Plan (2)	Lead/Ball Finish (6)	MSL Peak Temp (3)	Op Temp (°C)	Device Marking (4/5)	Samples
74AVC8T245RHRLRG4	ACTIVE	VQFN	RHL	24	1000	Green (RoHS & no Sb/Br)	CU NIPDAU	Level-2-260C-1 YEAR	-40 to 125	WE245	Samples
AVC8T245PWR-D	ACTIVE	TSSOP	PW	24	2000	Green (RoHS & no Sb/Br)	CU NIPDAU	Level-1-260C-UNLIM	-40 to 125	WE245	Samples
HPA00720RHLR	ACTIVE	VQFN	RHL	24	1000	Green (RoHS & no Sb/Br)	CU NIPDAU	Level-2-260C-1 YEAR	-40 to 125	WE245	Samples
SN74AVC8T245DGVR	ACTIVE	TVSOP	DGV	24	2000	Green (RoHS & no Sb/Br)	CU NIPDAU	Level-1-260C-UNLIM	-40 to 125	WE245	Samples
SN74AVC8T245PW	ACTIVE	TSSOP	PW	24	60	Green (RoHS & no Sb/Br)	CU NIPDAU	Level-1-260C-UNLIM	-40 to 125	WE245	Samples
SN74AVC8T245PWE4	ACTIVE	TSSOP	PW	24	60	Green (RoHS & no Sb/Br)	CU NIPDAU	Level-1-260C-UNLIM	-40 to 125	WE245	Samples
SN74AVC8T245PWG4	ACTIVE	TSSOP	PW	24	60	Green (RoHS & no Sb/Br)	CU NIPDAU	Level-1-260C-UNLIM	-40 to 125	WE245	Samples
SN74AVC8T245PWR	ACTIVE	TSSOP	PW	24	2000	Green (RoHS & no Sb/Br)	CU NIPDAU	Level-1-260C-UNLIM	-40 to 125	WE245	Samples
SN74AVC8T245PWRE4	ACTIVE	TSSOP	PW	24	2000	Green (RoHS & no Sb/Br)	CU NIPDAU	Level-1-260C-UNLIM	-40 to 125	WE245	Samples
SN74AVC8T245PWRG4	ACTIVE	TSSOP	PW	24	2000	Green (RoHS & no Sb/Br)	CU NIPDAU	Level-1-260C-UNLIM	-40 to 125	WE245	Samples
SN74AVC8T245RHRLR	ACTIVE	VQFN	RHL	24	1000	Green (RoHS & no Sb/Br)	CU NIPDAU	Level-2-260C-1 YEAR	-40 to 125	WE245	Samples

(1) The marketing status values are defined as follows:

ACTIVE: Product device recommended for new designs.

LIFEBUY: TI has announced that the device will be discontinued, and a lifetime-buy period is in effect.

NRND: Not recommended for new designs. Device is in production to support existing customers, but TI does not recommend using this part in a new design.

PREVIEW: Device has been announced but is not in production. Samples may or may not be available.

OBSOLETE: TI has discontinued the production of the device.

(2) **RoHS:** TI defines "RoHS" to mean semiconductor products that are compliant with the current EU RoHS requirements for all 10 RoHS substances, including the requirement that RoHS substance do not exceed 0.1% by weight in homogeneous materials. Where designed to be soldered at high temperatures, "RoHS" products are suitable for use in specified lead-free processes. TI may reference these types of products as "Pb-Free".

RoHS Exempt: TI defines "RoHS Exempt" to mean products that contain lead but are compliant with EU RoHS pursuant to a specific EU RoHS exemption.

Green: TI defines "Green" to mean the content of Chlorine (Cl) and Bromine (Br) based flame retardants meet JS709B low halogen requirements of <=1000ppm threshold. Antimony trioxide based flame retardants must also meet the <=1000ppm threshold requirement.

- (3) MSL, Peak Temp. - The Moisture Sensitivity Level rating according to the JEDEC industry standard classifications, and peak solder temperature.
- (4) There may be additional marking, which relates to the logo, the lot trace code information, or the environmental category on the device.
- (5) Multiple Device Markings will be inside parentheses. Only one Device Marking contained in parentheses and separated by a "~" will appear on a device. If a line is indented then it is a continuation of the previous line and the two combined represent the entire Device Marking for that device.
- (6) Lead/Ball Finish - Orderable Devices may have multiple material finish options. Finish options are separated by a vertical ruled line. Lead/Ball Finish values may wrap to two lines if the finish value exceeds the maximum column width.

Important Information and Disclaimer:The information provided on this page represents TI's knowledge and belief as of the date that it is provided. TI bases its knowledge and belief on information provided by third parties, and makes no representation or warranty as to the accuracy of such information. Efforts are underway to better integrate information from third parties. TI has taken and continues to take reasonable steps to provide representative and accurate information but may not have conducted destructive testing or chemical analysis on incoming materials and chemicals. TI and TI suppliers consider certain information to be proprietary, and thus CAS numbers and other limited information may not be available for release.

In no event shall TI's liability arising out of such information exceed the total purchase price of the TI part(s) at issue in this document sold by TI to Customer on an annual basis.

OTHER QUALIFIED VERSIONS OF SN74AVC8T245 :

- Automotive: [SN74AVC8T245-Q1](#)

NOTE: Qualified Version Definitions:

- Automotive - Q100 devices qualified for high-reliability automotive applications targeting zero defects

TAPE AND REEL INFORMATION

QUADRANT ASSIGNMENTS FOR PIN 1 ORIENTATION IN TAPE

*All dimensions are nominal

Device	Package Type	Package Drawing	Pins	SPQ	Reel Diameter (mm)	Reel Width W1 (mm)	A0 (mm)	B0 (mm)	K0 (mm)	P1 (mm)	W (mm)	Pin1 Quadrant
SN74AVC8T245DGVR	TVSOP	DGV	24	2000	330.0	12.4	6.9	5.6	1.6	8.0	12.0	Q1
SN74AVC8T245PWR	TSSOP	PW	24	2000	330.0	16.4	6.95	8.3	1.6	8.0	16.0	Q1
SN74AVC8T245RHLR	VQFN	RHL	24	1000	180.0	12.4	3.8	5.8	1.2	8.0	12.0	Q1

TAPE AND REEL BOX DIMENSIONS

*All dimensions are nominal

Device	Package Type	Package Drawing	Pins	SPQ	Length (mm)	Width (mm)	Height (mm)
SN74AVC8T245DGVR	TVSOP	DGV	24	2000	367.0	367.0	35.0
SN74AVC8T245PWR	TSSOP	PW	24	2000	367.0	367.0	38.0
SN74AVC8T245RHLR	VQFN	RHL	24	1000	210.0	185.0	35.0

PW0024A

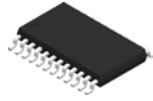

PACKAGE OUTLINE

TSSOP - 1.2 mm max height

SMALL OUTLINE PACKAGE

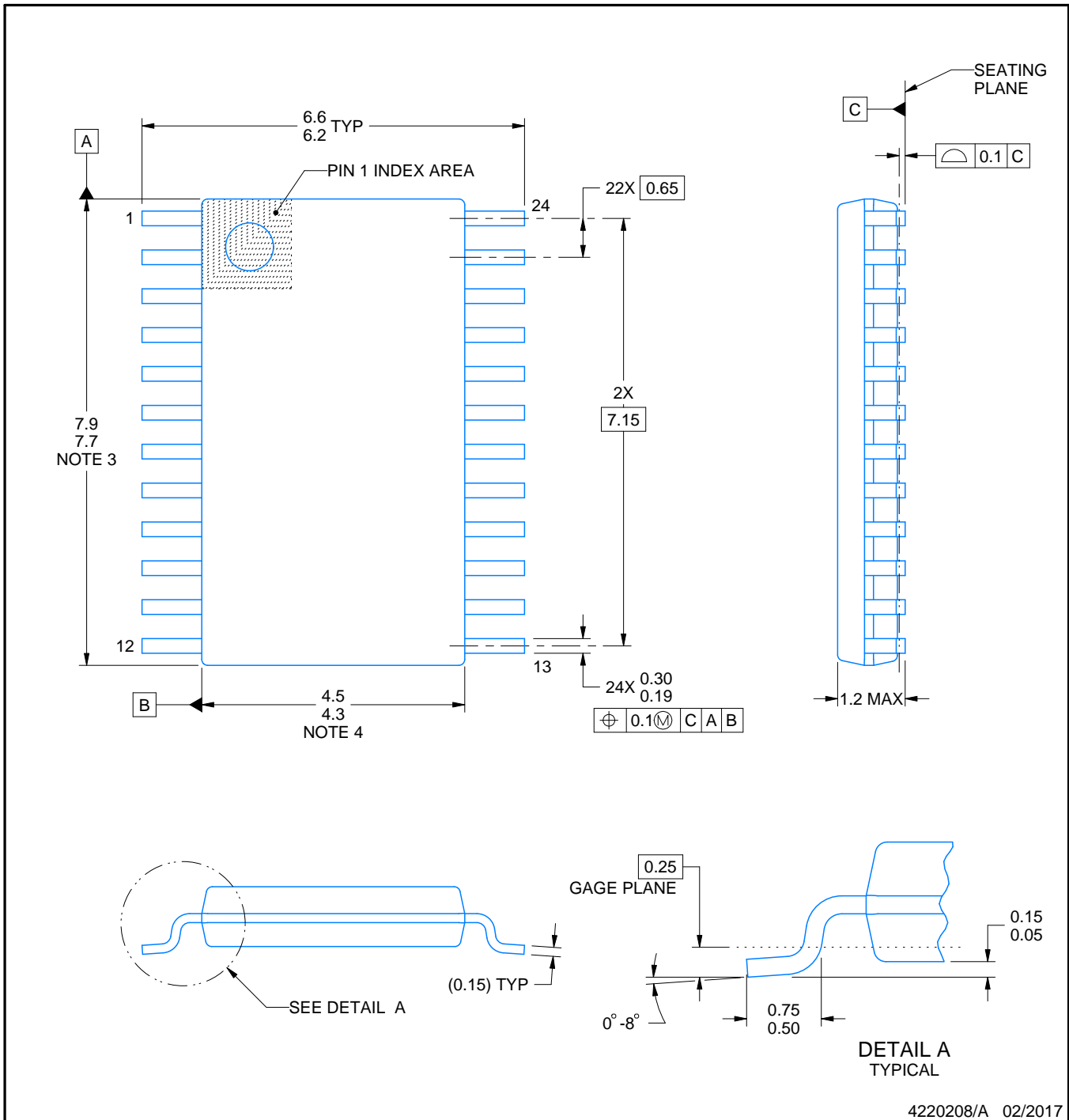

4220208/A 02/2017

NOTES:

1. All linear dimensions are in millimeters. Any dimensions in parenthesis are for reference only. Dimensioning and tolerancing per ASME Y14.5M.
2. This drawing is subject to change without notice.
3. This dimension does not include mold flash, protrusions, or gate burrs. Mold flash, protrusions, or gate burrs shall not exceed 0.15 mm per side.
4. This dimension does not include interlead flash. Interlead flash shall not exceed 0.25 mm per side.
5. Reference JEDEC registration MO-153.

EXAMPLE BOARD LAYOUT

PW0024A

TSSOP - 1.2 mm max height

SMALL OUTLINE PACKAGE

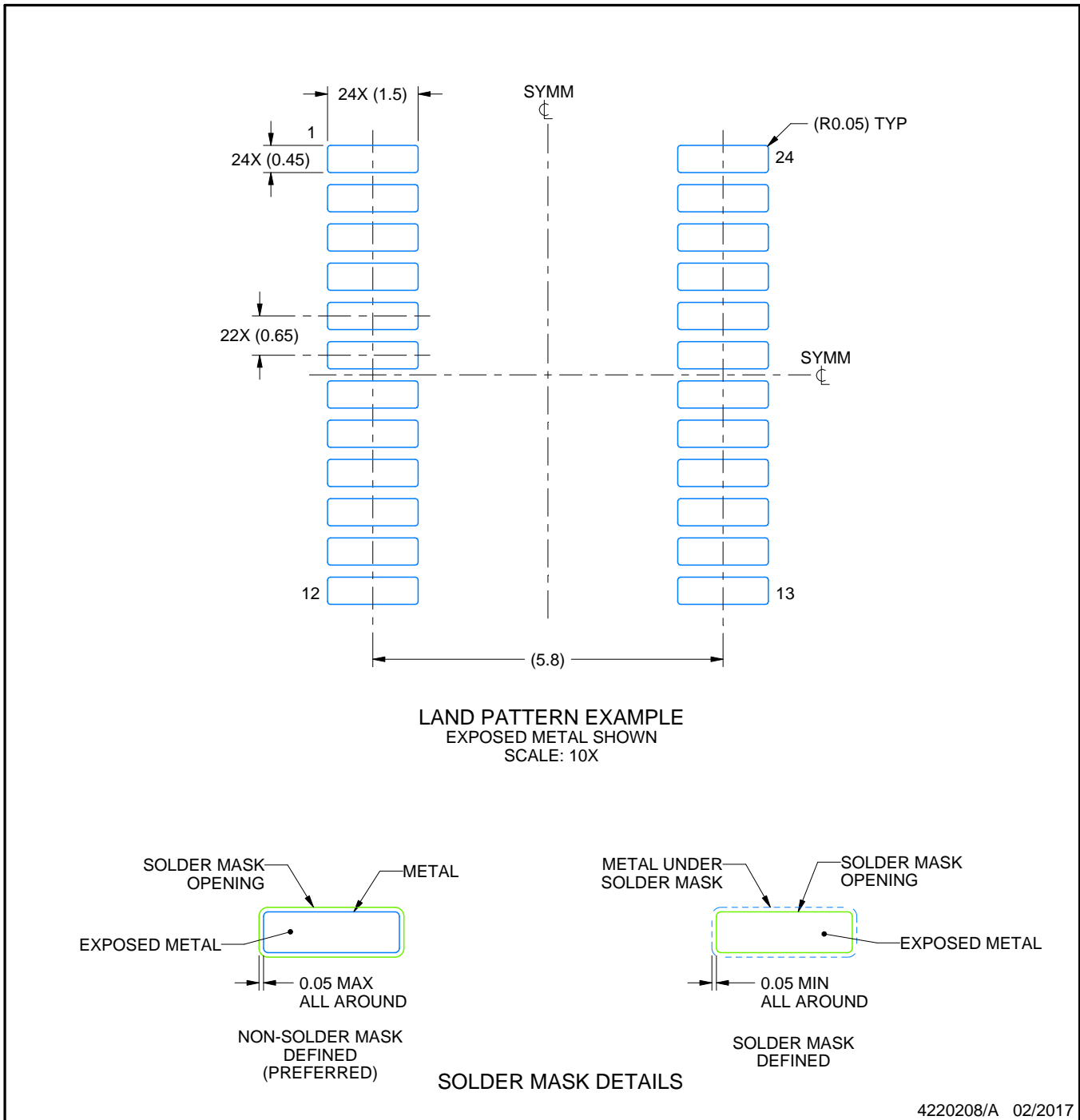

NOTES: (continued)

6. Publication IPC-7351 may have alternate designs.
7. Solder mask tolerances between and around signal pads can vary based on board fabrication site.

EXAMPLE STENCIL DESIGN

PW0024A

TSSOP - 1.2 mm max height

SMALL OUTLINE PACKAGE

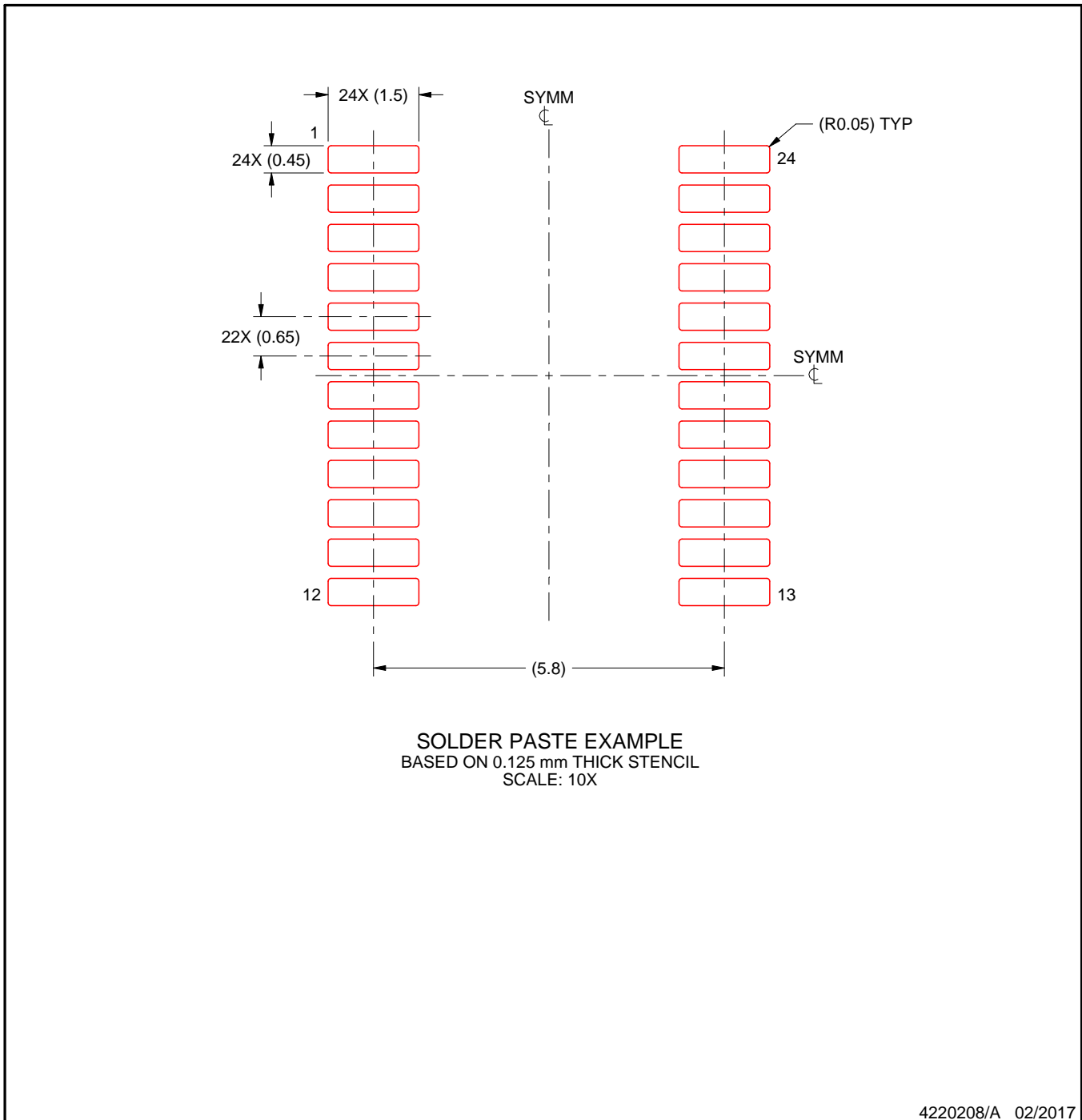

NOTES: (continued)

8. Laser cutting apertures with trapezoidal walls and rounded corners may offer better paste release. IPC-7525 may have alternate design recommendations.
9. Board assembly site may have different recommendations for stencil design.

DGV (R-PDSO-G**)

PLASTIC SMALL-OUTLINE

24 PINS SHOWN



- NOTES: A. All linear dimensions are in millimeters.
 B. This drawing is subject to change without notice.
 C. Body dimensions do not include mold flash or protrusion, not to exceed 0,15 per side.
 D. Falls within JEDEC: 24/48 Pins – MO-153
 14/16/20/56 Pins – MO-194

MECHANICAL DATA

RHL (R-PVQFN-N24)

PLASTIC QUAD FLATPACK NO-LEAD

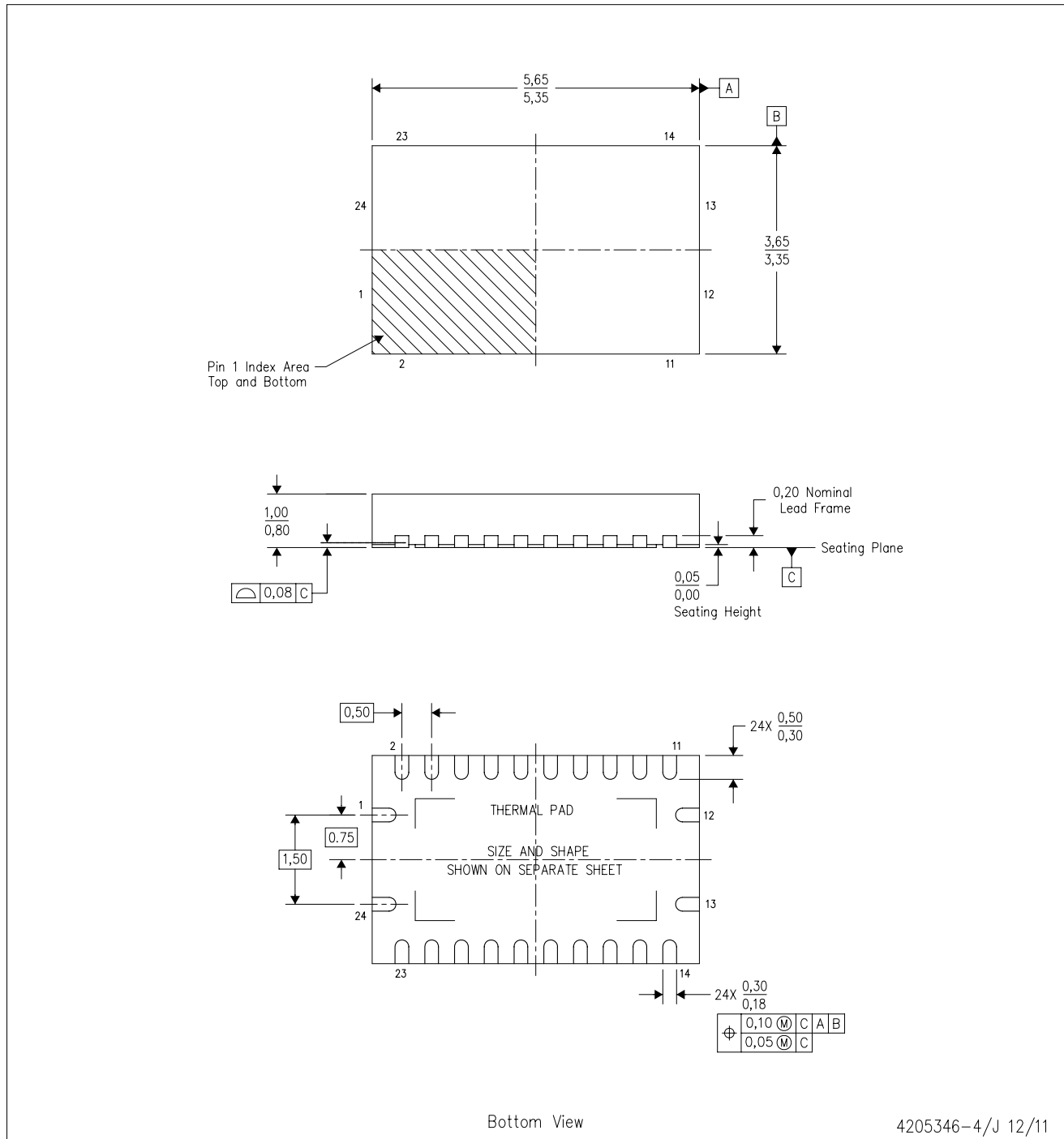

4205346-4/J 12/11

- NOTES:
- All linear dimensions are in millimeters. Dimensioning and tolerancing per ASME Y14.5M-1994.
 - This drawing is subject to change without notice.
 - QFN (Quad Flatpack No-Lead) package configuration.
 - The package thermal pad must be soldered to the board for thermal and mechanical performance.
 - See the additional figure in the Product Data Sheet for details regarding the exposed thermal pad features and dimensions.
 - JEDEC MO-241 package registration pending.

THERMAL PAD MECHANICAL DATA

RHL (S-PVQFN-N24)

PLASTIC QUAD FLATPACK NO-LEAD

THERMAL INFORMATION

This package incorporates an exposed thermal pad that is designed to be attached directly to an external heatsink. The thermal pad must be soldered directly to the printed circuit board (PCB). After soldering, the PCB can be used as a heatsink. In addition, through the use of thermal vias, the thermal pad can be attached directly to the appropriate copper plane shown in the electrical schematic for the device, or alternatively, can be attached to a special heatsink structure designed into the PCB. This design optimizes the heat transfer from the integrated circuit (IC).

For information on the Quad Flatpack No-Lead (QFN) package and its advantages, refer to Application Report, QFN/SON PCB Attachment, Texas Instruments Literature No. SLUA271. This document is available at www.ti.com.

The exposed thermal pad dimensions for this package are shown in the following illustration.

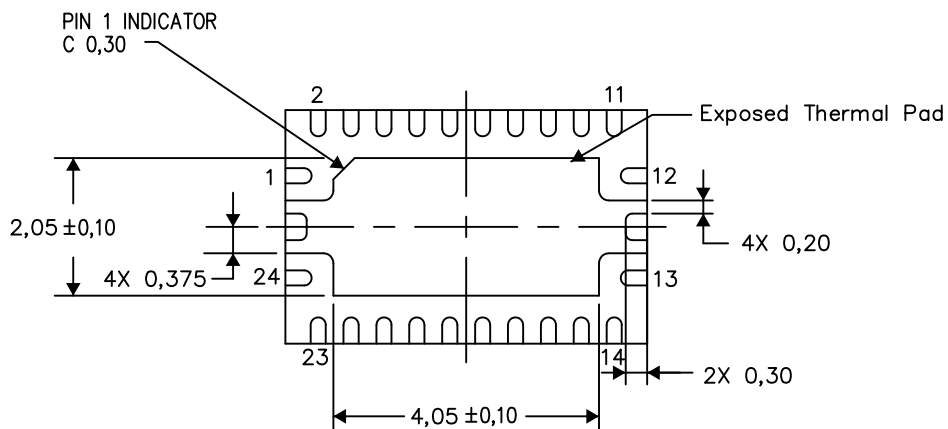

Bottom View

Exposed Thermal Pad Dimensions

4206363-4/N 07/14

NOTE: All linear dimensions are in millimeters

RHL (R-PVQFN-N24)

PLASTIC QUAD FLATPACK NO-LEAD

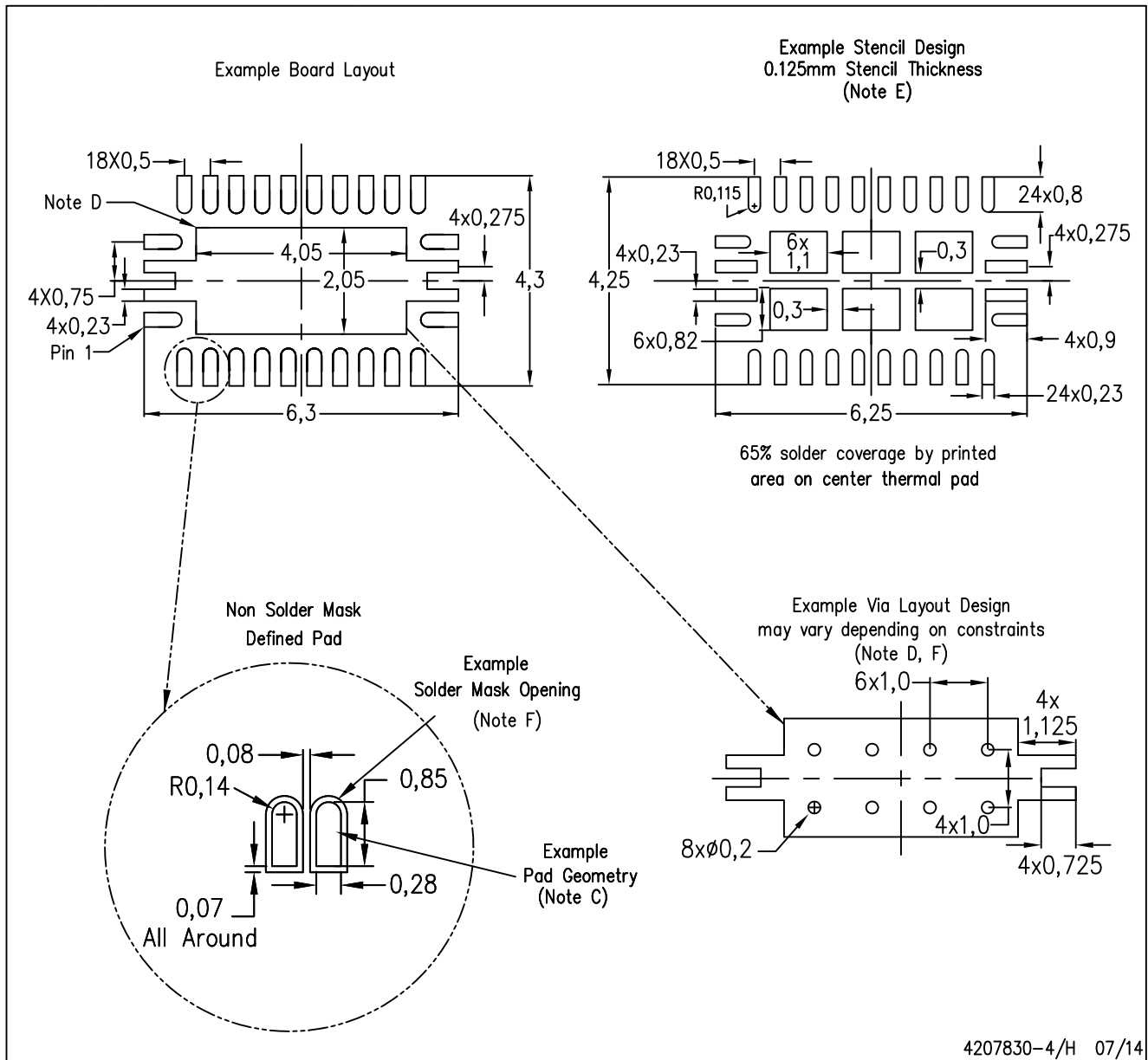

- NOTES:
- All linear dimensions are in millimeters.
 - This drawing is subject to change without notice.
 - Publication IPC-7351 is recommended for alternate designs.
 - This package is designed to be soldered to a thermal pad on the board. Refer to Application Note, Quad Flat-Pack Packages, Texas Instruments Literature No. SLUA271, and also the Product Data Sheets for specific thermal information, via requirements, and recommended board layout. These documents are available at www.ti.com <<http://www.ti.com>>.
 - Laser cutting apertures with trapezoidal walls and also rounding corners will offer better paste release. Customers should contact their board assembly site for stencil design recommendations. Refer to IPC 7525 for stencil design considerations.
 - Customers should contact their board fabrication site for minimum solder mask web tolerances between signal pads.

IMPORTANT NOTICE AND DISCLAIMER

TI PROVIDES TECHNICAL AND RELIABILITY DATA (INCLUDING DATASHEETS), DESIGN RESOURCES (INCLUDING REFERENCE DESIGNS), APPLICATION OR OTHER DESIGN ADVICE, WEB TOOLS, SAFETY INFORMATION, AND OTHER RESOURCES "AS IS" AND WITH ALL FAULTS, AND DISCLAIMS ALL WARRANTIES, EXPRESS AND IMPLIED, INCLUDING WITHOUT LIMITATION ANY IMPLIED WARRANTIES OF MERCHANTABILITY, FITNESS FOR A PARTICULAR PURPOSE OR NON-INFRINGEMENT OF THIRD PARTY INTELLECTUAL PROPERTY RIGHTS.

These resources are intended for skilled developers designing with TI products. You are solely responsible for (1) selecting the appropriate TI products for your application, (2) designing, validating and testing your application, and (3) ensuring your application meets applicable standards, and any other safety, security, or other requirements. These resources are subject to change without notice. TI grants you permission to use these resources only for development of an application that uses the TI products described in the resource. Other reproduction and display of these resources is prohibited. No license is granted to any other TI intellectual property right or to any third party intellectual property right. TI disclaims responsibility for, and you will fully indemnify TI and its representatives against, any claims, damages, costs, losses, and liabilities arising out of your use of these resources.

TI's products are provided subject to TI's Terms of Sale (www.ti.com/legal/termsofsale.html) or other applicable terms available either on ti.com or provided in conjunction with such TI products. TI's provision of these resources does not expand or otherwise alter TI's applicable warranties or warranty disclaimers for TI products.

Mailing Address: Texas Instruments, Post Office Box 655303, Dallas, Texas 75265
Copyright © 2019, Texas Instruments Incorporated

Looking for pricing, stock, or lifecycle information?

Click below to explore more details on WIN SOURCE:

 [View SN74AVC8T245PW on WIN SOURCE](#)

 [Texas Instruments](#) Information

Optimize Your Supply Chain with WIN SOURCE Solutions

-  Global Sourcing Solution
-  Obsolete Management
-  Cost Control Management
-  Shortage Management
-  Alternative Solution
-  Excess Inventory Management