



**THE DATASHEET OF
SN74AVC4T774RSVR**



SN74AVC4T774 4-Bit Dual-Supply Bus Transceiver With Configurable Voltage-Level Shifting and 3-State Outputs With Independent Direction Control Inputs

1 Features

- Each channel has an independent DIR control input
- Control inputs V_{IH}/V_{IL} levels are referenced to V_{CCA} voltage
- Fully configurable dual-rail design allows each port to operate over the full 1.1V to 3.6V power-supply range
- I/Os are 4.6V tolerant
- I_{off} Supports partial power-down-mode operation
- Typical data rates
 - 380Mbps (1.8V to 3.3V translation)
 - 200Mbps (<1.8V to 3.3V translation)
 - 200Mbps (translate to 2.5V or 1.8V)
 - 150Mbps (translate to 1.5V)
 - 100Mbps (translate to 1.2V)
- Latch-up performance exceeds 100 mA Per JESD 78, class II
- ESD Protection exceeds the following levels (tested per JESD 22)
 - $\pm 8000V$ Human-body model (A114-A)
 - 250V Machine model (A115-A)
 - $\pm 1500V$ Charged-device model (C101)

2 Applications

- [Personal electronic](#)
- [Industrial](#)
- [Enterprise](#)
- [Telecom](#)

3 Description

This 4-bit noninverting bus transceiver uses two separate configurable power-supply rails. The A port is designed to track V_{CCA} . V_{CCA} accepts any supply voltage from 1.1 V to 3.6V. The B port is designed to track V_{CCB} . V_{CCB} accepts any supply voltage from 1.1 to 3.6V. The SN74AVC4T774 is optimized to operate with V_{CCA}/V_{CCB} set at 1.4V to 3.6V. It is operational with V_{CCA}/V_{CCB} as low as 1.2V. This allows for universal low-voltage bi-directional translation between any of the 1.2V, 1.5V, 1.8V, 2.5V, and 3.3V voltage nodes.

The SN74AVC4T774 is designed for asynchronous communication between data buses. The logic levels of the direction-control (DIR) input and the output-

enable (\overline{OE}) input activate either the B-port outputs or the A-port outputs or place both output ports in the high-impedance mode. The device transmits data from the A bus to the B bus when the B outputs are activated, and from the B bus to the A bus when the A outputs are activated. The input circuitry on both A and B ports is always active and must have a logic HIGH or LOW level applied to prevent excess I_{CC} and I_{CCZ} .

The SN74AVC4T774 is designed so that the control pins (DIR1, DIR2, DIR3, DIR4, and \overline{OE}) are supplied by V_{CCA} . This device is fully specified for partial-power-down applications using I_{off} . The I_{off} circuitry disables the outputs, preventing damaging current backflow through the device when it is powered down. The V_{CC} isolation feature ensures that if either V_{CC} input is at GND, then both ports are in the high-impedance state.

For a high-impedance state during power-up or power-down, \overline{OE} should be tied to V_{CCA} through a pullup resistor; the minimum value of the resistor is determined by the current-sinking capability of the driver. Since this device has CMOS inputs, it is very important to not allow them to float. If the inputs are not driven to either a high V_{CC} state, or a low-GND state, an undesirable larger than expected I_{CC} current may result. Since the input voltage settlement is governed by many factors (for example, capacitance, board-layout, package inductance, surrounding conditions, and so forth), ensuring that they these inputs are kept out of erroneous switching states and tying them to either a high or a low level minimizes the leakage-current.

Package Information

| PART NUMBER | PACKAGE ⁽¹⁾ | PACKAGE SIZE ⁽²⁾ |
|--------------|------------------------|-----------------------------|
| SN74AVC4T774 | TSSOP (PW, 16) | 5mm × 4.40mm |
| | VQFN (RGY, 16) | 4mm × 3.5mm |
| | UQFN (RSV, 16) | 2.6mm × 1.8mm |
| | BQB (WQFN, 16) | 3.5mm × 2.5mm |
| | DYY (SOT, 16) | 4.2mm × 2mm |

(1) For more information, [Section 11](#).

(2) The package size (length × width) is a nominal value and includes pins, where applicable.



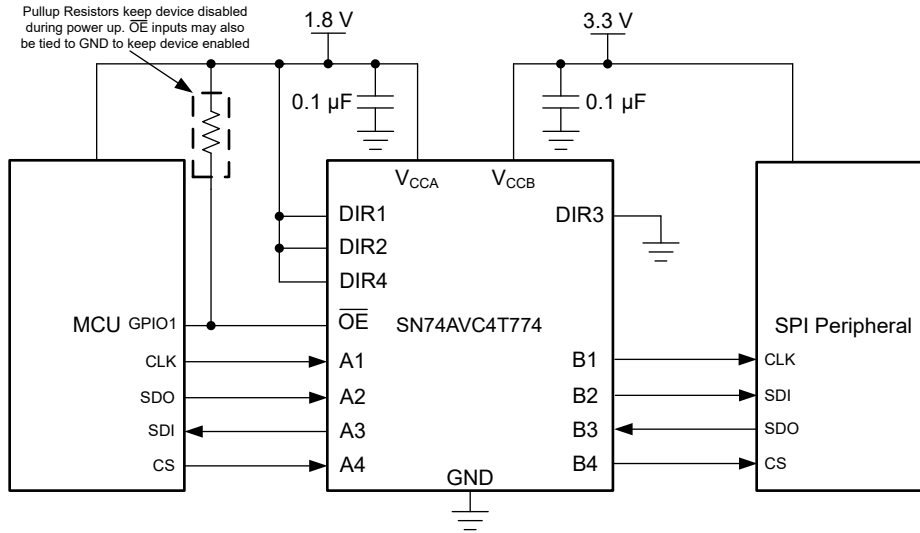

Typical Application Schematic

Table of Contents

| | | | |
|-----------------------------------------------------------|----|------------------------------------------------------------------|----|
| 1 Features | 1 | 7.1 Overview..... | 15 |
| 2 Applications | 1 | 7.2 Functional Block Diagram..... | 15 |
| 3 Description | 1 | 7.3 Feature Description..... | 15 |
| 4 Pin Configuration and Functions | 4 | 7.4 Device Functional Modes..... | 15 |
| 5 Specifications | 6 | 8 Application and Implementation | 16 |
| 5.1 Absolute Maximum Ratings | 6 | 8.1 Application Information..... | 16 |
| 5.2 ESD Ratings | 6 | 8.2 Typical Application..... | 16 |
| 5.3 Recommended Operating Conditions | 6 | 8.3 Power Supply Recommendations..... | 17 |
| 5.4 Thermal Information..... | 7 | 8.4 Layout..... | 17 |
| 5.5 Electrical Characteristics | 8 | 9 Device and Documentation Support | 19 |
| 5.6 Switching Characteristics: VCCA = 1.2 V ± 0.1 V | 9 | 9.1 Documentation Support..... | 19 |
| 5.7 Switching Characteristics: VCCA = 1.5 V ± 0.1 V | 9 | 9.2 Receiving Notification of Documentation Updates.... | 19 |
| 5.8 Switching Characteristics: VCCA = 1.8 V ± 0.15 V .. | 10 | 9.3 Support Resources..... | 19 |
| 5.9 Switching Characteristics: VCCA = 2.5 V ± 0.2 V | 10 | 9.4 Trademarks..... | 19 |
| 5.10 Switching Characteristics: VCCA = 3.3 V ± 0.3 V .. | 11 | 9.5 Electrostatic Discharge Caution..... | 19 |
| 5.11 Typical Characteristics..... | 12 | 9.6 Glossary..... | 19 |
| 6 Parameter Measurement Information | 13 | 10 Revision History | 20 |
| 6.1 Load Circuit and Voltage Waveforms..... | 13 | 11 Mechanical, Packaging, and Orderable Information | 20 |
| 7 Detailed Description | 15 | | |

4 Pin Configuration and Functions

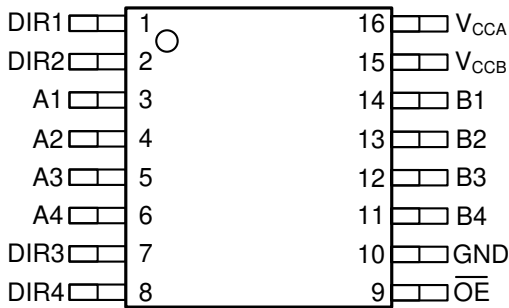

A. Shown for a single channel

Figure 4-1. PW Package, 16-Pin TSSOP (Top View)

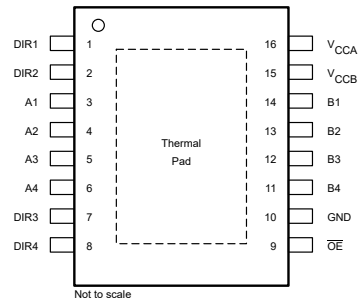

Figure 4-2. DYY Package, 16-Pin SOT (Top View)

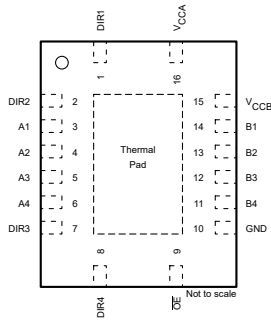

Figure 4-3. RGY Package, 16-Pin VQFN (Top View)

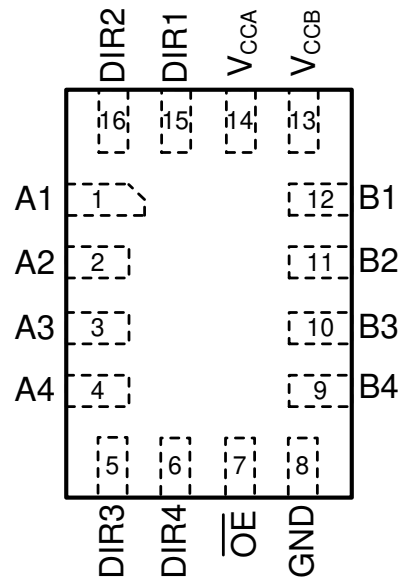

Figure 4-4. RSV Package, 16-Pin UQFN (Top View)

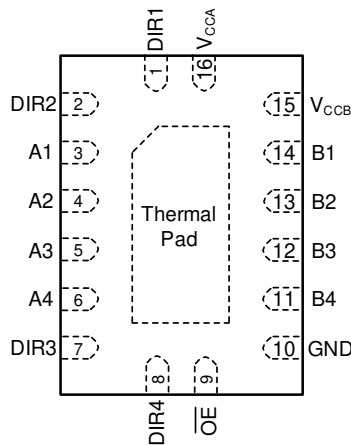

Figure 4-5. BQB Package, 16-Pin WQFN, Transparent (Top View)

Table 4-1. Pin Functions

| PIN | | | TYPE | DESCRIPTION |
|-----------------|-------------------------|-----|------|------------------------------------------------------------------------------------------------------------------------|
| NAME | PW RGY BQB DYY | RSV | | |
| DIR1 | 1 | 15 | I | Direction-control input referenced to V_{CCA} , controls signal flow for the first (A1/B1) I/O channels. |
| DIR2 | 2 | 16 | I | Direction-control input referenced to V_{CCA} , controls signal flow for the second (A2/B2) I/O channels. |
| A1 | 3 | 1 | I/O | Input/output A1. Referenced to V_{CCA} . |
| A2 | 4 | 2 | I/O | Input/output A2. Referenced to V_{CCA} . |
| A3 | 5 | 3 | I/O | Input/output A3. Referenced to V_{CCA} . |
| A4 | 6 | 4 | I/O | Input/output A4. Referenced to V_{CCA} . |
| DIR3 | 7 | 5 | I | Direction-control input referenced to V_{CCA} , controls signal flow for the third (A3/B3) I/O channels. |
| DIR4 | 8 | 6 | I | Direction-control input referenced to V_{CCA} , controls signal flow for the fourth (A4/B4) I/O channels. |
| \overline{OE} | 9 | 7 | I | 3-state output-mode enables. Pull \overline{OE} high to place all outputs in 3-state mode. Referenced to V_{CCA} . |
| GND | 10 | 8 | — | Ground. |
| B4 | 11 | 9 | I/O | Input/output B4. Referenced to V_{CCB} . |
| B3 | 12 | 10 | I/O | Input/output B3. Referenced to V_{CCB} . |
| B2 | 13 | 11 | I/O | Input/output B2. Referenced to V_{CCB} . |
| B1 | 14 | 12 | I/O | Input/output B1. Referenced to V_{CCB} . |
| V_{CCB} | 15 | 13 | — | B-port supply voltage. $1.1V \leq V_{CCB} \leq 3.6V$. |
| V_{CCA} | 16 | 14 | — | A-port supply voltage. $1.1V \leq V_{CCA} \leq 3.6V$. |

5 Specifications

5.1 Absolute Maximum Ratings

over operating free-air temperature range (unless otherwise noted)⁽¹⁾

| | | | MIN | MAX | UNIT |
|------------------|-----------------------------------------------------------------------------------------------|--------------------|------|------------|------|
| VCCA VCCB | Supply voltage | | -0.5 | 4.6 | V |
| VI | Input voltage range ⁽²⁾ | I/O ports (A port) | -0.5 | 4.6 | V |
| | | I/O ports (B port) | -0.5 | 4.6 | |
| | | Control inputs | -0.5 | 4.6 | |
| VO | Voltage range applied to any output in the high-impedance or power-off state ⁽²⁾ | A port | -0.5 | 4.6 | V |
| | | B port | -0.5 | 4.6 | |
| VO | Voltage range applied to any output in the high or low state ⁽²⁾ ⁽³⁾ | A port | -0.5 | VCCA + 0.5 | V |
| | | B port | -0.5 | VCCB + 0.5 | |
| I _{IK} | Input clamp current | VI < 0 | | -50 | mA |
| I _{OK} | Output clamp current | VO < 0 | | -50 | mA |
| IO | Continuous output current | | | ±50 | mA |
| | Continuous current through VCCA, VCCB, or GND | | | ±100 | |
| T _J | Junction temperature | | | 150 | °C |
| T _{stg} | Storage temperature | | -65 | 150 | °C |

- (1) Stresses beyond those listed under [Absolute Maximum Ratings](#) may cause permanent damage to the device. These are stress ratings only, and functional operation of the device at these or any other conditions beyond those indicated under [Recommended Operating Conditions](#) is not implied. Exposure to absolute-maximum-rated conditions for extended periods may affect device reliability.
- (2) The input voltage and output negative-voltage ratings may be exceeded if the input and output current ratings are observed.
- (3) The output positive-voltage rating may be exceeded up to 4.6 V maximum if the output current rating is observed.

5.2 ESD Ratings

| | | | VALUE | UNIT |
|--------------------|-------------------------|--------------------------------------------------------------------------------|-------|------|
| V _(ESD) | Electrostatic discharge | Human body model (HBM), per ANSI/ESDA/JEDEC JS-001 ⁽¹⁾ | ±8000 | V |
| | | Charged device model (CDM), per JEDEC specification JESD22-C101 ⁽²⁾ | ±1000 | |
| | | Machine model (A115-A) | 250 | |

- (1) JEDEC document JEP155 states that 500-V HBM allows safe manufacturing with a standard ESD control process.
- (2) JEDEC document JEP157 states that 250-V CDM allows safe manufacturing with a standard ESD control process.

5.3 Recommended Operating Conditions

over operating free-air temperature range (unless otherwise noted)⁽¹⁾ ⁽²⁾ ⁽³⁾

| | | | V _{CCI} | V _{CCO} | MIN | MAX | UNIT |
|------------------|--------------------------|----------------------------|------------------|------------------|-------------------------|-----|------|
| V _{CCA} | Supply voltage | | | | 1.1 | 3.6 | V |
| V _{CCB} | Supply voltage | | | | 1.1 | 3.6 | V |
| V _{IH} | High-level input voltage | Data inputs ⁽⁴⁾ | 1.1 V to 1.95 V | | V _{CCI} × 0.65 | | V |
| | | | 1.95 V to 2.7 V | | 1.6 | | |
| | | | 2.7 V to 3.6 V | | 2 | | |
| V _{IL} | Low-level input voltage | Data inputs ⁽⁴⁾ | 1.1 V to 1.95 V | | V _{CCI} × 0.35 | | V |
| | | | 1.95 V to 2.7 V | | 0.7 | | |
| | | | 2.7 V to 3.6 V | | 0.8 | | |

5.3 Recommended Operating Conditions (continued)

over operating free-air temperature range (unless otherwise noted)^{(1) (2) (3)}

| | | | V _{CCI} | V _{CCO} | MIN | MAX | UNIT |
|---------------------|------------------------------------|------------------------------------------------------------------------------------------|------------------|------------------|-------------------------|-------------------------|------|
| V _{IH} | High-level input voltage | Control Inputs (referenced to V _{CCA}) ⁽⁵⁾ (DIRx, \overline{OE}) | 1.1 V to 1.95 V | | V _{CCA} × 0.65 | | V |
| | | | 1.95 V to 2.7 V | | 1.6 | | |
| | | | 2.7 V to 3.6 V | | 2 | | |
| V _{IL} | Low-level input voltage | Control Inputs (referenced to V _{CCA}) ⁽⁵⁾ (DIRx, \overline{OE}) | 1.1 V to 1.95 V | | | V _{CCA} × 0.35 | V |
| | | | 1.95 V to 2.7 V | | | 0.7 | |
| | | | 2.7 V to 3.6 V | | | 0.8 | |
| V _I | Input voltage | | | | 0 | 3.6 | V |
| V _O | Output voltage | Active state | | | 0 | V _{CCO} | V |
| | | 3-state | | | 0 | 3.6 | |
| I _{OH} | High-level output current | | | 1.1 V to 1.3 V | | -3 | mA |
| | | | | 1.4 V to 1.6 V | | -6 | |
| | | | | 1.65 V to 1.95 V | | -8 | |
| | | | | 2.3 V to 2.7 V | | -9 | |
| | | | | 3 V to 3.6 V | | -12 | |
| I _{OL} | Low-level output current | | | 1.1 V to 1.3 V | | 3 | mA |
| | | | | 1.4 V to 1.6 V | | 6 | |
| | | | | 1.65 V to 1.95 V | | 8 | |
| | | | | 2.3 V to 2.7 V | | 9 | |
| | | | | 3 V to 3.6 V | | 12 | |
| $\Delta t/\Delta v$ | Input transition rise or fall rate | | | | | 5 | ns/V |
| T _A | Operating free-air temperature | | | | -40 | 85 | °C |

- (1) V_{CCI} is the V_{CC} associated with the input port.
- (2) V_{CCO} is the V_{CC} associated with the output port.
- (3) All unused data inputs of the device must be held at V_{CCI} or GND to ensure proper device operation. Refer to the TI application report, [Implications of Slow or Floating CMOS Inputs](#).
- (4) For V_{CCI} values not specified in the data sheet, V_{IH} min = V_{CCI} × 0.7 V, V_{IL} max = V_{CCI} × 0.3 V
- (5) For V_{CCI} values not specified in the data sheet, V_{IH} min = V_{CCA} × 0.7 V, V_{IL} max = V_{CCA} × 0.3 V

5.4 Thermal Information

| THERMAL METRIC ⁽¹⁾ | | SN74AVC4T774 | | | | | UNIT |
|-------------------------------|----------------------------------------------|--------------|------------|-----------|------------|------------|------|
| | | RGY (VQFN) | RSV (UQFN) | DYY (SOT) | BQB (WQFN) | PW (TSSOP) | |
| | | 16 PINS | 16 PINS | 16 PINS | 16 PINS | 16 PINS | |
| R _{θJA} | Junction-to-ambient thermal resistance | 37.7 | 139.2 | 163.4 | 79.1 | 123.8 | °C/W |
| R _{θJC(top)} | Junction-to-case (top) thermal resistance | 56.1 | 64.9 | 90.0 | 77.5 | 58.3 | °C/W |
| R _{θJB} | Junction-to-board thermal resistance | 15.9 | 67.7 | 93.1 | 49.0 | 81.7 | °C/W |
| Y _{JT} | Junction-to-top characterization parameter | 0.5 | 1.7 | 10.9 | 7.3 | 6.7 | °C/W |
| Y _{JB} | Junction-to-board characterization parameter | 16.1 | 67.4 | 92.1 | 48.9 | 80.9 | °C/W |
| R _{θJC(bottom)} | Junction-to-case (bottom) thermal resistance | N/A | N/A | N/A | 26.4 | N/A | °C/W |

- (1) For more information about traditional and new thermal metrics, see the [Semiconductor and IC Package Thermal Metrics](#) application report.

5.5 Electrical Characteristics

over recommended operating free-air temperature range (unless otherwise noted)^{(1) (2) (3)}

| PARAMETER | TEST CONDITIONS | V _{CCA} | V _{CCB} | TA = 25°C | | | –40°C to 85°C | | | UN IT |
|-------------------------------------|-------------------------------------------------------------------------------------------------------------------------------------------------------------------|-----------------------------------------------------------------------------------------------------------------------|------------------|----------------|--------|-------|---------------|------------------------|-----|----------|
| | | | | MIN | TYP | MAX | MIN | TYP | MAX | |
| V _{OH} | I _{OH} = –100 μA I _{OH} = –3 mA I _{OH} = –6 mA I _{OH} = –8 mA I _{OH} = –9 mA I _{OH} = –12 mA | V _I = V _{IH} | 1.1 V to 3.6 V | 1.1 V to 3.6 V | | | | V _{CCO} – 0.2 | V | |
| | | | 1.2 V | 1.2 V | 0.95 | | | | | |
| | | | 1.4 V | 1.4 V | | 1.05 | | | | |
| | | | 1.65 V | 1.65 V | | 1.2 | | | | |
| | | | 2.3 V | 2.3 V | | 1.75 | | | | |
| | | | 3 V | 3 V | | 2.3 | | | | |
| V _{OL} | I _{OL} = 100 μA I _{OL} = 3 mA I _{OL} = 6 mA I _{OL} = 8 mA I _{OL} = 9 mA I _{OL} = 12 mA | V _I = V _{IL} | 1.1 V to 3.6 V | 1.1 V to 3.6 V | | | | 0.2 | V | |
| | | | 1.2 V | 1.2 V | 0.25 | | | | | |
| | | | 1.4 V | 1.4 V | | 0.35 | | | | |
| | | | 1.65 V | 1.65 V | | 0.45 | | | | |
| | | | 2.3 V | 2.3 V | | 0.55 | | | | |
| | | | 3 V | 3 V | | 0.7 | | | | |
| I _I | Control inputs | V _I = V _{CCA} or GND | 1.1 V to 3.6 V | 1.1 V to 3.6 V | ±0.025 | ±0.25 | | ±1 | μA | |
| I _{off} | A or B port | V _I or V _O = 0 to 3.6 V | 0 V | 0 V to 3.6 V | ±0.1 | ±1 | | ±5 | μA | |
| | | | 0 V to 3.6 V | 0 V | ±0.1 | ±1 | ±5 | | | |
| I _{OZ} | A or B port | V _O = V _{CCO} or GND, V _I = V _{CCI} or GND, \overline{OE} = V _{IH} | 3.6 V | 3.6 V | ±0.5 | ±2.5 | | ±5 | μA | |
| I _{CCA} | | V _I = V _{CCI} or GND, I _O = 0 | 1.1 V to 3.6 V | 1.1 V to 3.6 V | | | | 8 | μA | |
| | | | 0 V | 0 V to 3.6 V | | | –2 | | | |
| | | | 0 V to 3.6 V | 0 V | | | 8 | | | |
| I _{CCB} | | V _I = V _{CCI} or GND, I _O = 0 | 1.1 V to 3.6 V | 1.1 V to 3.6 V | | | | 8 | μA | |
| | | | 0 V | 0 V to 3.6 V | | | 8 | | | |
| | | | 0 V to 3.6 V | 0 V | | | –2 | | | |
| I _{CCA} + I _{CCB} | | V _I = V _{CCI} or GND, I _O = 0 | 1.1 V to 3.6 V | 1.1 V to 3.6 V | | | | 16 | μA | |
| C _i | Control inputs | V _I = 3.3 V or GND | 3.3 V | 3.3 V | 2.5 | | | 4.5 | pF | |
| C _{io} | A or B port | V _O = 3.3 V or GND | 3.3 V | 3.3 V | 5 | | | 7 | pF | |

(1) V_{CCI} is the V_{CC} associated with the input port.

(2) V_{CCO} is the V_{CC} associated with the output port.

(3) All unused data inputs of the device must be held at V_{CCI} or GND to ensure proper device operation. Refer to the TI application report, [Implications of Slow or Floating CMOS Inputs](#).

5.6 Switching Characteristics: $V_{CCA} = 1.2\text{ V} \pm 0.1\text{ V}$

See Figure 8-1 and Table 8-1 for test circuit and loading. See Figure 8-2, Figure 8-3, and Figure 8-4 for measurement waveforms.

| PARAMETER | PARAMETER | FROM | TO | Test Conditions | $V_{CCB} = 1.2\text{ V} \pm 0.1\text{ V}$ | | $V_{CCB} = 1.5\text{ V} \pm 0.1\text{ V}$ | | $V_{CCB} = 1.8\text{ V} \pm 0.15\text{ V}$ | | $V_{CCB} = 2.5\text{ V} \pm 0.2\text{ V}$ | | $V_{CCB} = 3.3\text{ V} \pm 0.3\text{ V}$ | | UNIT |
|-----------|-----------|-----------------|----|-----------------|-------------------------------------------|-----|-------------------------------------------|-----|--------------------------------------------|-----|-------------------------------------------|-----|-------------------------------------------|-----|------|
| | | | | | MIN | MAX | MIN | MAX | MIN | MAX | MIN | MAX | MIN | MAX | |
| t_{PLH} | t_{PLH} | A | B | -40°C to 85°C | 2 | 7.5 | 1.5 | 5.5 | 1 | 4.5 | 1 | 4 | 0.5 | 4 | ns |
| t_{PHL} | t_{PHL} | | | | 1.5 | 5.5 | 1 | 4 | 1 | 4 | 0.5 | 4.5 | 0.5 | 6 | |
| t_{PLH} | t_{PLH} | B | A | | 2 | 7 | 1.5 | 6.5 | 1 | 6 | 1 | 6 | 1 | 6 | |
| t_{PHL} | t_{PHL} | | | | 1.5 | 5.5 | 1 | 5 | 1 | 4.5 | 0.5 | 4 | 0.5 | 4 | |
| t_{PZH} | t_{PZH} | \overline{OE} | A | | 2.5 | 8 | 2 | 8 | 1 | 8 | 1 | 8 | 1 | 8.5 | |
| t_{PZL} | t_{PZL} | | | | 2.5 | 9 | 2 | 9 | 1.5 | 9 | 1 | 9 | 1 | 9 | |
| t_{PZH} | t_{PZH} | \overline{OE} | B | | 2 | 7.5 | 1.5 | 5.5 | 1 | 6.5 | 1 | 9.5 | 0.5 | 30 | |
| t_{PZL} | t_{PZL} | | | | 2.5 | 8.5 | 1.5 | 6.5 | 1 | 7 | 1 | 8.5 | 0.5 | 24 | |
| t_{PHZ} | t_{PHZ} | \overline{OE} | A | | 3 | 6.5 | 2 | 6.5 | 2 | 6.5 | 1.5 | 6.5 | 2 | 6.5 | |
| t_{PLZ} | t_{PLZ} | | | | 3 | 6.5 | 2.5 | 6.5 | 2.5 | 6.5 | 2 | 6.5 | 2 | 6.5 | |
| t_{PHZ} | t_{PHZ} | \overline{OE} | B | | 3 | 6 | 2.5 | 5.5 | 2 | 6 | 1.5 | 5 | 2 | 6.5 | |
| t_{PLZ} | t_{PLZ} | | | | 3 | 6 | 2.5 | 5.5 | 2.5 | 5.5 | 1.5 | 5 | 2 | 6 | |

5.7 Switching Characteristics: $V_{CCA} = 1.5\text{ V} \pm 0.1\text{ V}$

See Figure 8-1 and Table 8-1 for test circuit and loading. See Figure 8-2, Figure 8-3, and Figure 8-4 for measurement waveforms.

| PARAMETER | PARAMETER | FROM | TO | $V_{CCB} = 1.2\text{ V} \pm 0.1\text{ V}$ | | $V_{CCB} = 1.5\text{ V} \pm 0.1\text{ V}$ | | $V_{CCB} = 1.8\text{ V} \pm 0.15\text{ V}$ | | $V_{CCB} = 2.5\text{ V} \pm 0.2\text{ V}$ | | $V_{CCB} = 3.3\text{ V} \pm 0.3\text{ V}$ | | UNIT |
|-----------|-----------|-----------------|----|-------------------------------------------|-----|-------------------------------------------|------|--------------------------------------------|------|-------------------------------------------|------|-------------------------------------------|------|------|
| | | | | MIN | MAX | MIN | MAX | MIN | MAX | MIN | MAX | MIN | MAX | |
| t_{PLH} | t_{PLH} | A | B | 1.5 | 6.5 | 0.3 | 6.3 | 0.3 | 5.2 | 0.4 | 4.2 | 0.4 | 4.2 | ns |
| t_{PHL} | t_{PHL} | | | 1.5 | 4.5 | 0.3 | 6.3 | 0.3 | 5.2 | 0.4 | 4.2 | 0.4 | 4.2 | |
| t_{PLH} | t_{PLH} | B | A | 1.5 | 5 | 0.7 | 6.3 | 0.5 | 6 | 0.4 | 5.7 | 0.3 | 5.6 | ns |
| t_{PHL} | t_{PHL} | | | 1.5 | 4 | 0.7 | 6.3 | 0.5 | 6 | 0.4 | 5.7 | 0.3 | 5.6 | |
| t_{PZH} | t_{PZH} | \overline{OE} | A | 1.5 | 5 | 1.4 | 9.6 | 1.1 | 9.5 | 0.7 | 9.4 | 0.4 | 9.4 | ns |
| t_{PZL} | t_{PZL} | | | 2 | 5.5 | 1.4 | 9.6 | 1.1 | 9.5 | 0.7 | 9.4 | 0.4 | 9.4 | |
| t_{PZH} | t_{PZH} | \overline{OE} | B | 2 | 6.5 | 1.4 | 9.6 | 1.1 | 7.7 | 0.9 | 5.8 | 0.9 | 5.6 | ns |
| t_{PZL} | t_{PZL} | | | 2 | 7.5 | 1.4 | 9.6 | 1.1 | 7.7 | 0.9 | 5.8 | 0.9 | 5.6 | |
| t_{PHZ} | t_{PHZ} | \overline{OE} | A | 2 | 5 | 1.8 | 10.2 | 1.5 | 10.2 | 1.3 | 10.2 | 1.6 | 10.2 | ns |
| t_{PLZ} | t_{PLZ} | | | 2.5 | 4.5 | 1.8 | 10.2 | 1.5 | 10.2 | 1.3 | 10.2 | 1.6 | 10.2 | |
| t_{PHZ} | t_{PHZ} | \overline{OE} | B | 3 | 5.5 | 1.9 | 10.3 | 1.9 | 9.1 | 1.4 | 7.4 | 1.2 | 7.6 | ns |
| t_{PLZ} | t_{PLZ} | | | 3 | 5.5 | 1.9 | 10.3 | 1.9 | 9.1 | 1.4 | 7.4 | 1.2 | 7.6 | |

5.8 Switching Characteristics: $V_{CCA} = 1.8\text{ V} \pm 0.15\text{ V}$

See Figure 8-1 and Table 8-1 for test circuit and loading. See Figure 8-2, Figure 8-3, and Figure 8-4 for measurement waveforms.

| PARAMETER | PARAMETER | FROM | TO | Test Conditions | $V_{CCB} = 1.2\text{ V} \pm 0.1\text{ V}$ | | $V_{CCB} = 1.5\text{ V} \pm 0.1\text{ V}$ | | $V_{CCB} = 1.8\text{ V} \pm 0.15\text{ V}$ | | $V_{CCB} = 2.5\text{ V} \pm 0.2\text{ V}$ | | $V_{CCB} = 3.3\text{ V} \pm 0.3\text{ V}$ | | UNIT |
|-----------|-----------|-----------------|----|-----------------|-------------------------------------------|-----|-------------------------------------------|------|--------------------------------------------|------|-------------------------------------------|------|-------------------------------------------|------|------|
| | | | | | MIN | MAX | MIN | MAX | MIN | MAX | MIN | MAX | MIN | MAX | |
| t_{PLH} | t_{PLH} | A | B | -40°C to 85°C | 1.5 | 6.5 | 0.3 | 6.3 | 0.3 | 5.2 | 0.4 | 4.2 | 0.4 | 4.2 | ns |
| t_{PHL} | t_{PHL} | | | | 1 | 4.5 | 0.3 | 6.3 | 0.3 | 5.2 | 0.4 | 4.2 | 0.4 | 4.2 | |
| t_{PLH} | t_{PLH} | B | A | | 1.5 | 6 | 0.7 | 6.3 | 0.5 | 6 | 0.4 | 5.7 | 0.3 | 5.6 | |
| t_{PHL} | t_{PHL} | | | | 1 | 4.5 | 0.7 | 6.3 | 0.5 | 6 | 0.4 | 5.7 | 0.3 | 5.6 | |
| t_{PZH} | t_{PZH} | \overline{OE} | A | | 1 | 6.5 | 1.4 | 9.6 | 1.1 | 9.5 | 0.7 | 9.4 | 0.4 | 9.4 | |
| t_{PZL} | t_{PZL} | | | | 1.5 | 7.5 | 1.4 | 9.6 | 1.1 | 9.5 | 0.7 | 9.4 | 0.4 | 9.4 | |
| t_{PZH} | t_{PZH} | \overline{OE} | B | | 2 | 6 | 1.4 | 9.6 | 1.1 | 7.7 | 0.9 | 5.8 | 0.9 | 5.6 | |
| t_{PZL} | t_{PZL} | | | | 2 | 7 | 1.4 | 9.6 | 1.1 | 7.7 | 0.9 | 5.8 | 0.9 | 5.6 | |
| t_{PHZ} | t_{PHZ} | \overline{OE} | A | | 2 | 6 | 1.8 | 10.2 | 1.5 | 10.2 | 1.3 | 10.2 | 1.6 | 10.2 | |
| t_{PLZ} | t_{PLZ} | | | | 2.5 | 5.5 | 1.8 | 10.2 | 1.5 | 10.2 | 1.3 | 10.2 | 1.6 | 10.2 | |
| t_{PHZ} | t_{PHZ} | \overline{OE} | B | | 2.5 | 5 | 1.9 | 10.3 | 1.9 | 9.1 | 1.4 | 7.4 | 1.2 | 7.6 | |
| t_{PLZ} | t_{PLZ} | | | | 2.5 | 5 | 1.9 | 10.3 | 1.9 | 9.1 | 1.4 | 7.4 | 1.2 | 7.6 | |

5.9 Switching Characteristics: $V_{CCA} = 2.5\text{ V} \pm 0.2\text{ V}$

See Figure 8-1 and Table 8-1 for test circuit and loading. See Figure 8-2, Figure 8-3, and Figure 8-4 for measurement waveforms.

| PARAMETER | PARAMETER | FROM | TO | $V_{CCB} = 1.2\text{ V} \pm 0.1\text{ V}$ | | $V_{CCB} = 1.5\text{ V} \pm 0.1\text{ V}$ | | $V_{CCB} = 1.8\text{ V} \pm 0.15\text{ V}$ | | $V_{CCB} = 2.5\text{ V} \pm 0.2\text{ V}$ | | $V_{CCB} = 3.3\text{ V} \pm 0.3\text{ V}$ | | UNIT |
|-----------|-----------|-----------------|----|-------------------------------------------|-----|-------------------------------------------|-----|--------------------------------------------|-----|-------------------------------------------|-----|-------------------------------------------|-----|------|
| | | | | MIN | MAX | MIN | MAX | MIN | MAX | MIN | MAX | MIN | MAX | |
| t_{PLH} | t_{PLH} | A | B | 1.5 | 6.5 | 0.1 | 5.7 | 0.1 | 4.6 | 0.2 | 3.5 | 0.1 | 3.6 | ns |
| t_{PHL} | t_{PHL} | | | 1 | 4.5 | 0.1 | 5.7 | 0.1 | 4.6 | 0.2 | 3.5 | 0.1 | 3.6 | |
| t_{PLH} | t_{PLH} | B | A | 1.5 | 4 | 0.6 | 4.2 | 0.4 | 3.9 | 0.2 | 3.4 | 0.2 | 3.3 | ns |
| t_{PHL} | t_{PHL} | | | 1 | 5 | 0.6 | 4.2 | 0.4 | 3.9 | 0.2 | 3.4 | 0.2 | 3.3 | |
| t_{PZH} | t_{PZH} | \overline{OE} | A | 1 | 2.5 | 0.7 | 6.5 | 0.7 | 5.2 | 0.6 | 4.8 | 0.4 | 4.8 | ns |
| t_{PZL} | t_{PZL} | | | 1 | 3 | 0.7 | 6.5 | 0.7 | 5.2 | 0.6 | 4.8 | 0.4 | 4.8 | |
| t_{PZH} | t_{PZH} | \overline{OE} | B | 1.5 | 6 | 0.9 | 8.8 | 0.8 | 7 | 0.6 | 4.8 | 0.6 | 4 | ns |
| t_{PZL} | t_{PZL} | | | 2 | 7 | 0.9 | 8.8 | 0.8 | 7 | 0.6 | 4.8 | 0.6 | 4 | |
| t_{PHZ} | t_{PHZ} | \overline{OE} | A | 1.5 | 3.5 | 1 | 8.4 | 1 | 8.4 | 1 | 6.2 | 1 | 6.6 | ns |
| t_{PLZ} | t_{PLZ} | | | 2 | 3.5 | 1 | 8.4 | 1 | 8.4 | 1 | 6.2 | 1 | 6.6 | |
| t_{PHZ} | t_{PHZ} | \overline{OE} | B | 2 | 5 | 1.5 | 9.4 | 1.3 | 8.2 | 1.1 | 6.2 | 0.9 | 5.2 | ns |
| t_{PLZ} | t_{PLZ} | | | 2.5 | 5 | 1.5 | 9.4 | 1.3 | 8.2 | 1.1 | 6.2 | 0.9 | 5.2 | |

5.10 Switching Characteristics: $V_{CCA} = 3.3\text{ V} \pm 0.3\text{ V}$

See [Figure 8-1](#) and [Table 8-1](#) for test circuit and loading. See [Figure 8-2](#), [Figure 8-3](#), and [Figure 8-4](#) for measurement waveforms.

| PARAMETER | PARAMETER | FROM | TO | $V_{CCB} = 1.2\text{ V} \pm 0.1\text{ V}$ | | $V_{CCB} = 1.5\text{ V} \pm 0.1\text{ V}$ | | $V_{CCB} = 1.8\text{ V} \pm 0.15\text{ V}$ | | $V_{CCB} = 2.5\text{ V} \pm 0.2\text{ V}$ | | $V_{CCB} = 3.3\text{ V} \pm 0.3\text{ V}$ | | UNIT |
|-----------|-----------|-----------------|----|-------------------------------------------|-----|-------------------------------------------|-----|--------------------------------------------|-----|-------------------------------------------|-----|-------------------------------------------|-----|------|
| | | | | MIN | MAX | MIN | MAX | MIN | MAX | MIN | MAX | MIN | MAX | |
| t_{PLH} | t_{PLH} | A | B | 1.5 | 6 | 0.1 | 5.6 | 0.1 | 4.5 | 0.1 | 3.3 | 0.1 | 2.9 | ns |
| t_{PHL} | t_{PHL} | | | 1 | 4 | 0.1 | 5.6 | 0.1 | 4.5 | 0.1 | 3.3 | 0.1 | 2.9 | |
| t_{PLH} | t_{PLH} | B | A | 1.5 | 4 | 0.6 | 4.2 | 0.4 | 3.4 | 0.2 | 3 | 0.1 | 2.8 | ns |
| t_{PHL} | t_{PHL} | | | 1.5 | 7.5 | 0.6 | 4.2 | 0.4 | 3.4 | 0.2 | 3 | 0.1 | 2.8 | |
| t_{PZH} | t_{PZH} | \overline{OE} | A | 1 | 2.5 | 0.6 | 8.7 | 0.6 | 5.2 | 0.6 | 3.8 | 0.4 | 3.8 | ns |
| t_{PZL} | t_{PZL} | | | 1 | 2.5 | 0.6 | 8.7 | 0.6 | 5.2 | 0.6 | 3.8 | 0.4 | 3.8 | |
| t_{PZH} | t_{PZH} | \overline{OE} | B | 1.5 | 6 | 0.8 | 8.7 | 0.6 | 6.8 | 0.5 | 4.7 | 0.5 | 3.8 | ns |
| t_{PZL} | t_{PZL} | | | 1.5 | 7 | 0.8 | 8.7 | 0.6 | 6.8 | 0.5 | 4.7 | 0.5 | 3.8 | |
| t_{PHZ} | t_{PHZ} | \overline{OE} | A | 2 | 4 | 0.7 | 9.3 | 0.7 | 8.3 | 0.7 | 5.6 | 0.7 | 6.6 | ns |
| t_{PLZ} | t_{PLZ} | | | 2 | 4 | 0.7 | 9.3 | 0.7 | 8.3 | 0.7 | 5.6 | 0.7 | 6.6 | |
| t_{PHZ} | t_{PHZ} | \overline{OE} | B | 2 | 5 | 1.4 | 9.3 | 1.2 | 8.1 | 1 | 6.4 | 0.8 | 6.2 | ns |
| t_{PLZ} | t_{PLZ} | | | 2 | 4.5 | 1.4 | 9.3 | 1.2 | 8.1 | 1 | 6.4 | 0.8 | 6.2 | |

5.11 Typical Characteristics

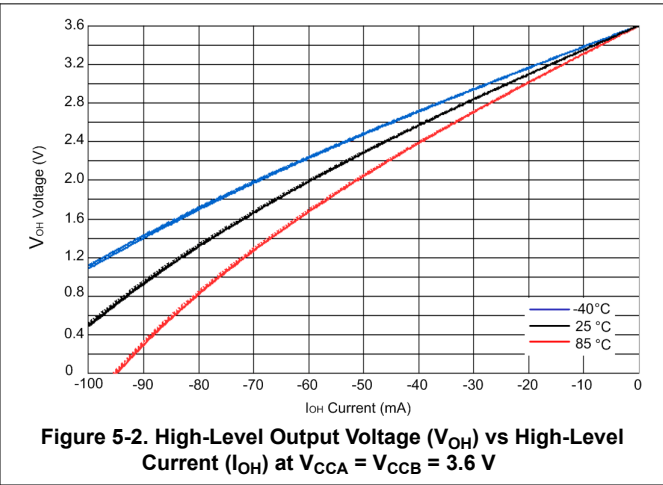
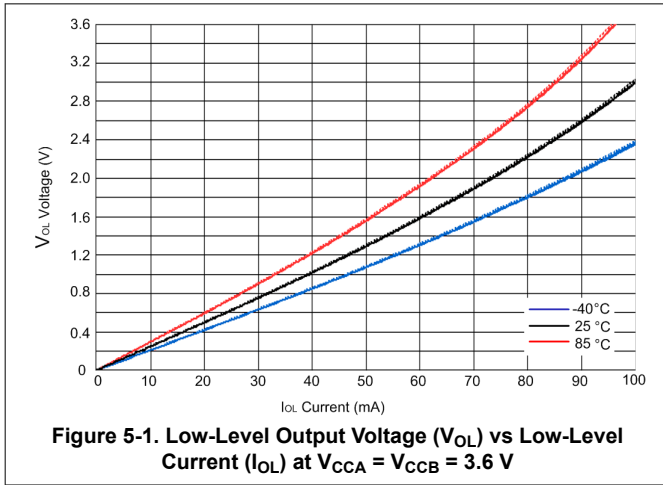

6 Parameter Measurement Information

6.1 Load Circuit and Voltage Waveforms

Unless otherwise noted, all input pulses are supplied by generators having the following characteristics:

- $f = 10 \text{ MHz}$
- $Z_O = 50 \Omega$
- $\Delta t/\Delta V \leq 1 \text{ ns/V}$

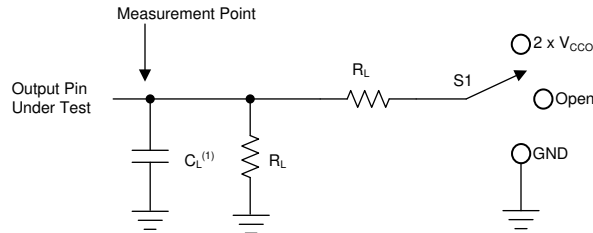

A. C_L includes probe and jig capacitance.

Figure 6-1. Load Circuit

Table 6-1. Load Circuit Parameters

| Test Parameter | | S_1 |
|--------------------|---------------------------|--------------------|
| t_{pd} | Propagation (delay) time | Open |
| t_{PZL}, t_{PLZ} | Enable time, disable time | $2 \times V_{CCO}$ |
| t_{PZH}, t_{PHZ} | Enable time, disable time | GND |

Table 6-2. Load Circuit Conditions

| V_{CCO} | R_L | C_L | V_{TP} |
|------------------------------------|--------------|-------|----------|
| $1.2 \text{ V} \pm 0.1 \text{ V}$ | 2 k Ω | 15 pF | 0.1 V |
| $1.5 \text{ V} \pm 0.1 \text{ V}$ | 2 k Ω | 15 pF | 0.1 V |
| $1.8 \text{ V} \pm 0.15 \text{ V}$ | 2 k Ω | 15 pF | 0.15 V |
| $2.5 \text{ V} \pm 0.2 \text{ V}$ | 2 k Ω | 15 pF | 0.15 V |
| $3.3 \text{ V} \pm 0.3 \text{ V}$ | 2 k Ω | 15 pF | 0.3 V |

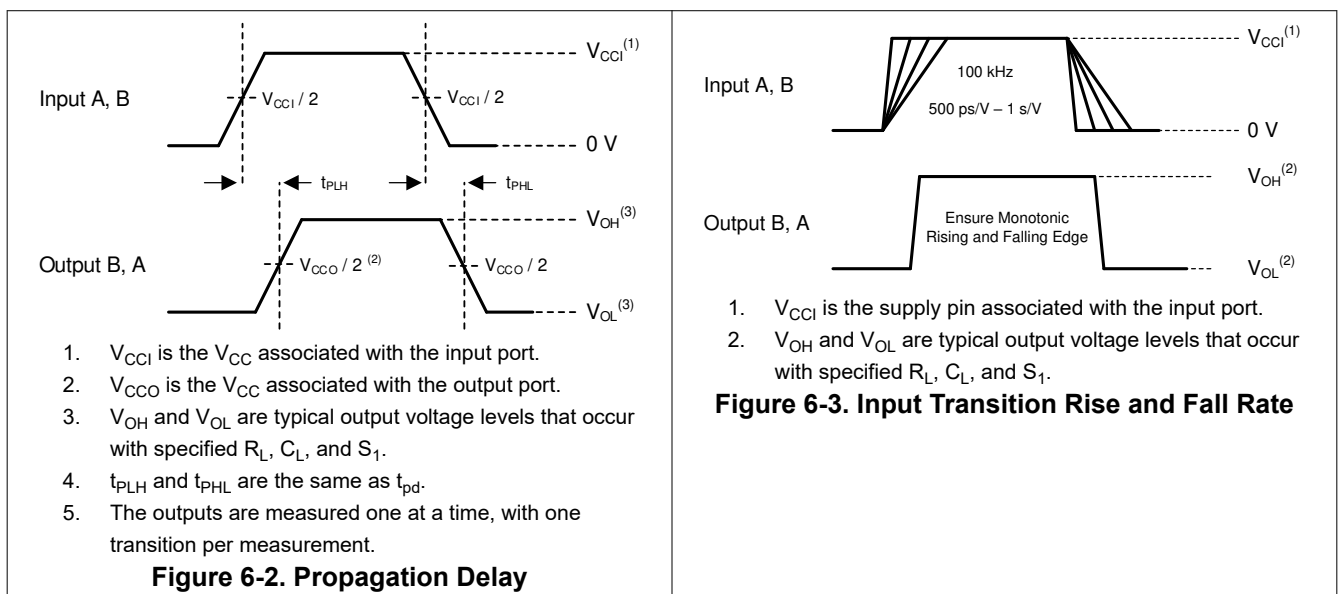

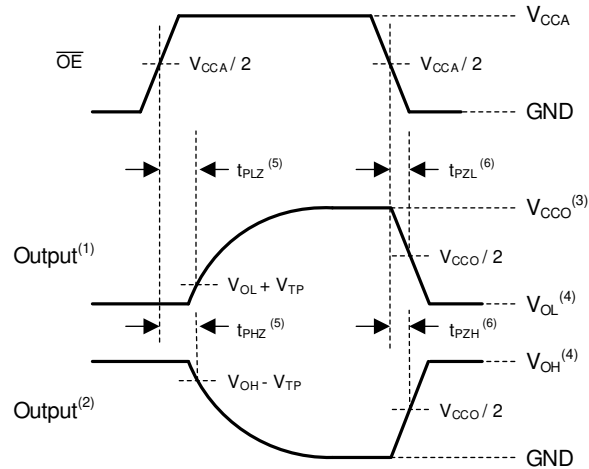

- A. Output waveform on the condition that input is driven to a valid Logic Low.
- B. Output waveform on the condition that input is driven to a valid Logic High.
- C. V_{CCO} is the supply pin associated with the output port.
- D. V_{OH} and V_{OL} are typical output voltage levels with specified R_L , C_L , and S_1 .
- E. t_{PLZ} and t_{PZH} are the same as t_{dis} .
- F. t_{PZL} and t_{PZH} are the same as t_{en} .

Figure 6-4. Enable Time And Disable Time

7 Detailed Description

7.1 Overview

The SN74AVC4T774 is a 4-bit, dual-supply, noninverting, bi-directional voltage level translation. Pins An and control pins (DIR1, DIR2, DIR3, DIR4 and \overline{OE}) are support by V_{CCA} and pins Bn are support by V_{CCB} . The A port is able to accept I/O voltages ranging from 1.1V to 3.6V, while the B port can accept I/O voltages from 1.1V to 3.6V. A high on DIR allows data transmission from An to Bn and a low on DIR allows data transmission from B to A when \overline{OE} is set to low. When \overline{OE} is set to high, both An and Bn are in the high-impedance state.

7.2 Functional Block Diagram

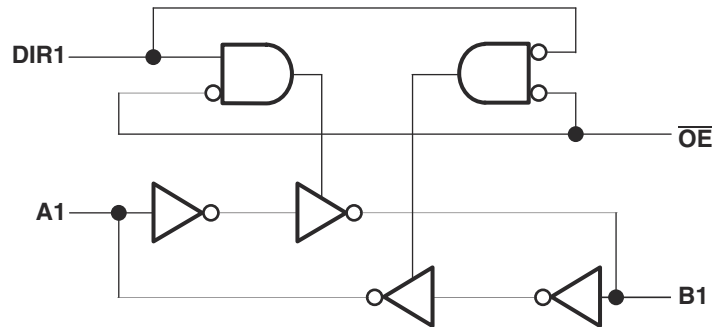

Figure 7-1. Logic Diagram (Positive Logic)

7.3 Feature Description

7.3.1 Fully Configurable Dual-Rail Design Allows Each Port to Operate Over the Full 1.1V to 3.6V Power-Supply Range

Both V_{CCA} and V_{CCB} can be supplied at any voltage between 1.1V and 3.6V making the device suitable for translating between any of the low-voltage nodes (1.2V, 1.8V, 2.5V and 3.3V).

7.3.2 Support High-Speed Translation

SN74AVC4T774 can support high data rate application. The translated signal data rate can be up to 380Mbps when signal is translated from 1.8V to 3.3V.

7.3.3 I_{off} Supports Partial-Power-Down Mode Operation

I_{off} will prevent backflow current by disabling I/O output circuits when device is in partial-power-down mode.

7.4 Device Functional Modes

Table 7-1. Function Table (Each Bit)

| CONTROL INPUTS | | OUTPUT CIRCUITS | | OPERATION |
|-----------------|-----|-----------------|---------|------------------|
| \overline{OE} | DIR | A PORT | B PORT | |
| L | L | Enabled | Hi-Z | B data to A data |
| L | H | Hi-Z | Enabled | A data to B data |
| H | X | Hi-Z | Hi-Z | Isolation |

8 Application and Implementation

Note

Information in the following applications sections is not part of the TI component specification, and TI does not warrant its accuracy or completeness. TI's customers are responsible for determining suitability of components for their purposes, as well as validating and testing their design implementation to confirm system functionality.

8.1 Application Information

The SN74AVC4T774 device can be used in level-translation applications for interfacing devices or systems operating at different interface voltages with one another. The device is designed for use in applications where a push-pull driver is connected to the data I/Os. The max data rate can be up to 380Mbps when the device translate signal is from 1.8V to 3.3V.

8.2 Typical Application

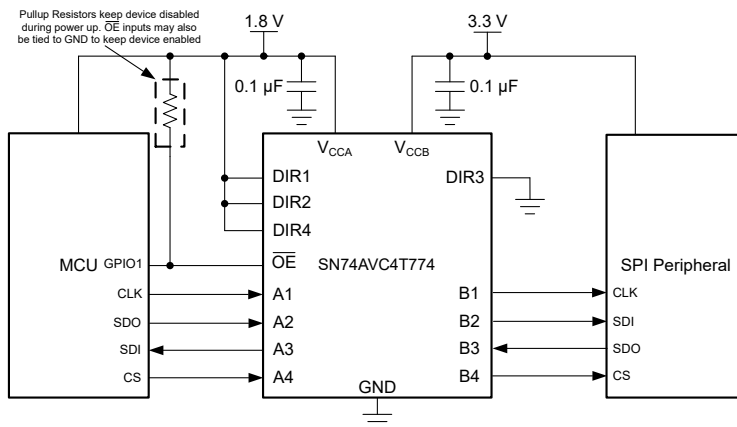

Figure 8-1. Typical Application of the SN74AVC4T774

8.2.1 Design Requirements

For this design example, use the parameters listed in [Table 8-1](#).

Table 8-1. Design Parameters

| DESIGN PARAMETERS | EXAMPLE VALUE |
|----------------------|---------------|
| Input Voltage Range | 1.1V to 3.6V |
| Output Voltage Range | 1.1V to 3.6V |

8.2.2 Detailed Design Procedure

To begin the design process, determine the following:

- Input voltage range
 - Use the supply voltage of the device that is driving the SN74AVC4T774 device to determine the input voltage range. For a valid logic high, the value must exceed the V_{IH} of the input port. For a valid logic low, the value must be less than the V_{IL} of the input port.
- Output voltage range
 - Use the supply voltage of the device that the SN74AVC4T774 device is driving to determine the output voltage range.

8.2.3 Application Curve

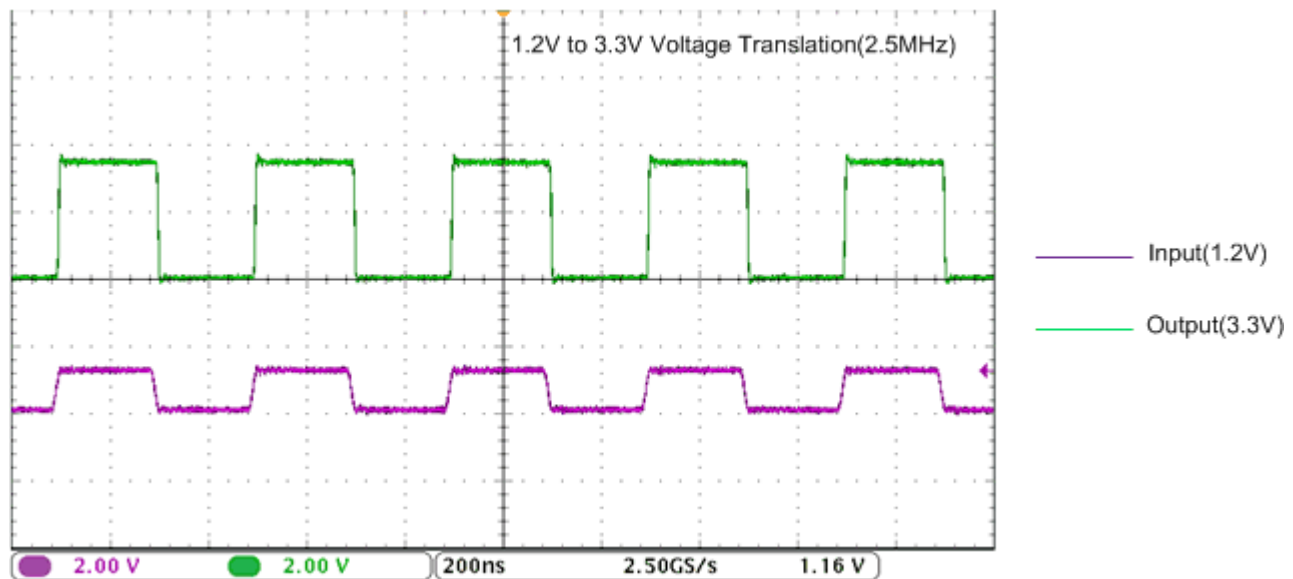

Figure 8-2. Translation Up (1.2 V to 3.3 V) at 2.5 MHz

8.3 Power Supply Recommendations

The SN74AVC4T774 device uses two separate configurable power-supply rails, V_{CCA} and V_{CCB} . V_{CCA} accepts any supply voltage from 1.1V to 3.6V and V_{CCB} accepts any supply voltage from 1.1V to 3.6V. The A port and B port are designed to track V_{CCA} and V_{CCB} respectively allowing for low-voltage, bi-directional translation between any of the 1.2V, 1.5V, 1.8V, 2.5V and 3.3V voltage nodes.

The output-enable \overline{OE} input circuit is designed so that it is supplied by V_{CCA} and when the \overline{OE} input is high, all outputs are placed in the high-impedance state. To ensure the high-impedance state of the outputs during power-up or power-down, the \overline{OE} input pin must be tied to V_{CCA} through a pullup resistor and must not be enabled until V_{CCA} and V_{CCB} are fully ramped and stable. The minimum value of the pullup resistor to V_{CCA} is determined by the current-sinking capability of the driver.

8.4 Layout

8.4.1 Layout Guidelines

For reliability of the device, following common printed-circuit board layout guidelines are recommended:

- Bypass capacitors should be used on power supplies.
- Short trace lengths should be used to avoid excessive loading.
- Placing pads on the signal paths for loading capacitors or pullup resistors to help adjust rise and fall times of signals depending on the system requirements

8.4.2 Layout Example

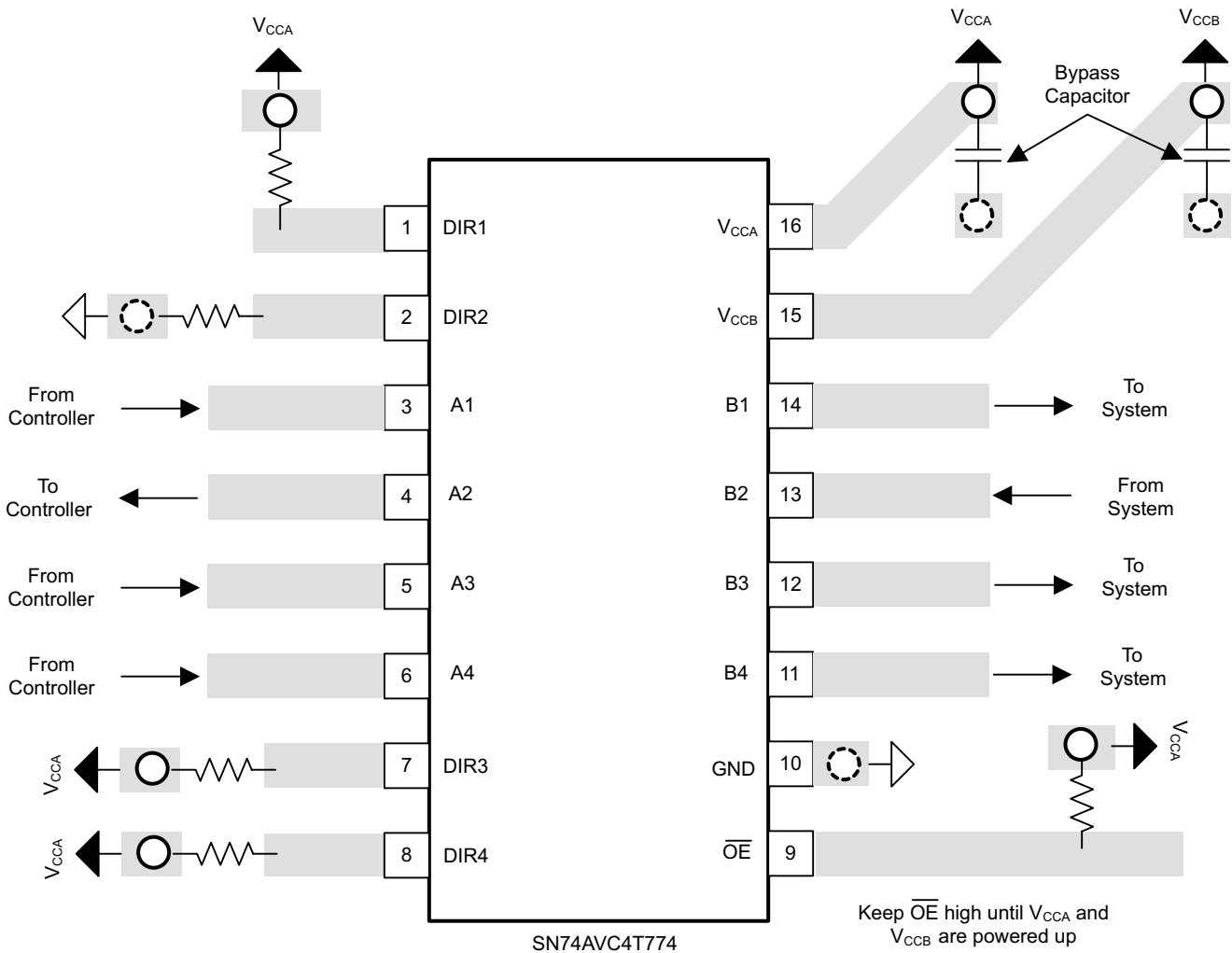
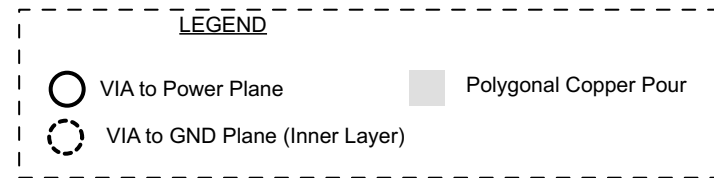

Figure 8-3. PCB Layout Example

9 Device and Documentation Support

9.1 Documentation Support

9.1.1 Related Documentation

For related documentation see the following:

- Texas Instruments, [16-Bit Widebus Logic Families in 56-Ball, 0.65-mm Pitch Very Thin Fine-Pitch BGA application report](#)
- Texas Instruments, [AVC Logic Family Technology and Applications application report](#)
- Texas Instruments, [AVC Advanced Very-Low-Voltage CMOS Logic Data Book, March 2000 data book](#)
- Texas Instruments, [Dynamic Output Control \(DOC\) Circuitry Technology And Applications \(Rev. B\) application report](#)
- Texas Instruments, [Introduction to Logic application report](#)
- Texas Instruments, [LCD Module Interface Application Clip brochure](#)
- Texas Instruments, [Logic Cross-Reference application note](#)
- Texas Instruments, [Logic Guide marketing selection guide](#)
- Texas Instruments, [LOGIC Pocket Data Book data book](#)
- Texas Instruments, [Selecting the Right Level Translation Solution application report](#)
- Texas Instruments, [Semiconductor Packing Material Electrostatic Discharge \(ESD\) Protection application report](#)
- Texas Instruments, [Solving CMOS Transition Rate Issues Using Schmitt Trigger Solution white paper](#)
- Texas Instruments, [Standard Linear & Logic for PCs, Servers & Motherboards brochure](#)
- Texas Instruments, [TI Tablet Solutions solution guide](#)
- Texas Instruments, [Understanding and Interpreting Standard-Logic Data Sheets application report](#)
- Texas Instruments, [Voltage Translation Between 3.3-V, 2.5-V, 1.8-V, and 1.5-V Logic Standards application report](#)

9.2 Receiving Notification of Documentation Updates

To receive notification of documentation updates, navigate to the device product folder on [ti.com](#). Click on *Notifications* to register and receive a weekly digest of any product information that has changed. For change details, review the revision history included in any revised document.

9.3 Support Resources

[TI E2E™ support forums](#) are an engineer's go-to source for fast, verified answers and design help — straight from the experts. Search existing answers or ask your own question to get the quick design help you need.

Linked content is provided "AS IS" by the respective contributors. They do not constitute TI specifications and do not necessarily reflect TI's views; see TI's [Terms of Use](#).

9.4 Trademarks

TI E2E™ is a trademark of Texas Instruments.
All trademarks are the property of their respective owners.

9.5 Electrostatic Discharge Caution



This integrated circuit can be damaged by ESD. Texas Instruments recommends that all integrated circuits be handled with appropriate precautions. Failure to observe proper handling and installation procedures can cause damage.

ESD damage can range from subtle performance degradation to complete device failure. Precision integrated circuits may be more susceptible to damage because very small parametric changes could cause the device not to meet its published specifications.

9.6 Glossary

[TI Glossary](#) This glossary lists and explains terms, acronyms, and definitions.

10 Revision History

NOTE: Page numbers for previous revisions may differ from page numbers in the current version.

Changes from Revision G (May 2021) to Revision H (March 2024) Page

- Added the BQB and DYY packages to the datasheet..... 1

Changes from Revision F (November 2020) to Revision G (May 2021) Page

- Updated the *Typical Application Schematic* figure in the *Description* section..... 1
- Updated the *Typical Application of the SN74AVC4T774* figure in the *Typical Application* section..... 16

Changes from Revision E (October 2017) to Revision F (November 2020) Page

- Updated the numbering format for tables, figures and cross-references throughout the document..... 1
- V_{CCA} and V_{CCB} supply voltage min in *Recommended Operating Conditions* table expanded down to 1.1V..... 6

Changes from Revision D (January 2015) to Revision E (October 2017) Page

- Added Storage junction temperature to *Absolute Maximum Ratings* 6

Changes from Revision C (December 2014) to Revision D (January 2015) Page

- Changed Pin Functions table order for Pins B4, B3, B2 and B1..... 4

Changes from Revision B (May 2008) to Revision C (December 2014) Page

- Added *Pin Configuration and Functions* section, *ESD Ratings* table, *Feature Description* section, *Device Functional Modes, Application and Implementation* section, *Power Supply Recommendations* section, *Layout* section, *Device and Documentation Support* section, and *Mechanical, Packaging, and Orderable Information* section 1

11 Mechanical, Packaging, and Orderable Information

The following pages include mechanical, packaging, and orderable information. This information is the most current data available for the designated devices. This data is subject to change without notice and revision of this document. For browser-based versions of this data sheet, refer to the left-hand navigation.

PACKAGING INFORMATION

| Orderable Device | Status (1) | Package Type | Package Drawing | Pins | Package Qty | Eco Plan (2) | Lead finish/ Ball material (6) | MSL Peak Temp (3) | Op Temp (°C) | Device Marking (4/5) | Samples |
|-------------------|---------------|--------------|-----------------|------|-------------|-----------------|--------------------------------------|----------------------|--------------|-------------------------|-------------------------|
| 74AVC4T774RSVR-NT | ACTIVE | UQFN | RSV | 16 | 3000 | RoHS & Green | NIPDAU | Level-1-260C-UNLIM | -40 to 85 | ZVK | Samples |
| 74AVC4T774RSVRG4 | ACTIVE | UQFN | RSV | 16 | 3000 | RoHS & Green | NIPDAU | Level-1-260C-UNLIM | -40 to 85 | ZVK | Samples |
| SN74AVC4T774PW | ACTIVE | TSSOP | PW | 16 | 90 | RoHS & Green | NIPDAU | Level-1-260C-UNLIM | -40 to 85 | WT774 | Samples |
| SN74AVC4T774PWR | ACTIVE | TSSOP | PW | 16 | 2000 | RoHS & Green | NIPDAU | Level-1-260C-UNLIM | -40 to 85 | WT774 | Samples |
| SN74AVC4T774RGYR | ACTIVE | VQFN | RGY | 16 | 3000 | RoHS & Green | NIPDAU | Level-2-260C-1 YEAR | -40 to 85 | WT774 | Samples |
| SN74AVC4T774RSVR | ACTIVE | UQFN | RSV | 16 | 3000 | RoHS & Green | NIPDAU | Level-1-260C-UNLIM | -40 to 85 | ZVK | Samples |

(1) The marketing status values are defined as follows:

ACTIVE: Product device recommended for new designs.

LIFEBUY: TI has announced that the device will be discontinued, and a lifetime-buy period is in effect.

NRND: Not recommended for new designs. Device is in production to support existing customers, but TI does not recommend using this part in a new design.

PREVIEW: Device has been announced but is not in production. Samples may or may not be available.

OBSOLETE: TI has discontinued the production of the device.

(2) **RoHS:** TI defines "RoHS" to mean semiconductor products that are compliant with the current EU RoHS requirements for all 10 RoHS substances, including the requirement that RoHS substance do not exceed 0.1% by weight in homogeneous materials. Where designed to be soldered at high temperatures, "RoHS" products are suitable for use in specified lead-free processes. TI may reference these types of products as "Pb-Free".

RoHS Exempt: TI defines "RoHS Exempt" to mean products that contain lead but are compliant with EU RoHS pursuant to a specific EU RoHS exemption.

Green: TI defines "Green" to mean the content of Chlorine (Cl) and Bromine (Br) based flame retardants meet JS709B low halogen requirements of <=1000ppm threshold. Antimony trioxide based flame retardants must also meet the <=1000ppm threshold requirement.

(3) MSL, Peak Temp. - The Moisture Sensitivity Level rating according to the JEDEC industry standard classifications, and peak solder temperature.

(4) There may be additional marking, which relates to the logo, the lot trace code information, or the environmental category on the device.

(5) Multiple Device Markings will be inside parentheses. Only one Device Marking contained in parentheses and separated by a "-" will appear on a device. If a line is indented then it is a continuation of the previous line and the two combined represent the entire Device Marking for that device.

(6) Lead finish/Ball material - Orderable Devices may have multiple material finish options. Finish options are separated by a vertical ruled line. Lead finish/Ball material values may wrap to two lines if the finish value exceeds the maximum column width.

Important Information and Disclaimer: The information provided on this page represents TI's knowledge and belief as of the date that it is provided. TI bases its knowledge and belief on information provided by third parties, and makes no representation or warranty as to the accuracy of such information. Efforts are underway to better integrate information from third parties. TI has taken and continues to take reasonable steps to provide representative and accurate information but may not have conducted destructive testing or chemical analysis on incoming materials and chemicals. TI and TI suppliers consider certain information to be proprietary, and thus CAS numbers and other limited information may not be available for release.

In no event shall TI's liability arising out of such information exceed the total purchase price of the TI part(s) at issue in this document sold by TI to Customer on an annual basis.

TAPE AND REEL INFORMATION

QUADRANT ASSIGNMENTS FOR PIN 1 ORIENTATION IN TAPE

*All dimensions are nominal

| Device | Package Type | Package Drawing | Pins | SPQ | Reel Diameter (mm) | Reel Width W1 (mm) | A0 (mm) | B0 (mm) | K0 (mm) | P1 (mm) | W (mm) | Pin1 Quadrant |
|-------------------|--------------|-----------------|------|------|--------------------|--------------------|---------|---------|---------|---------|--------|---------------|
| 74AVC4T774RSVR-NT | UQFN | RSV | 16 | 3000 | 180.0 | 9.5 | 2.1 | 2.9 | 0.75 | 4.0 | 8.0 | Q1 |
| SN74AVC4T774PWR | TSSOP | PW | 16 | 2000 | 330.0 | 12.4 | 6.9 | 5.6 | 1.6 | 8.0 | 12.0 | Q1 |
| SN74AVC4T774RGYR | VQFN | RGY | 16 | 3000 | 330.0 | 12.4 | 3.8 | 4.3 | 1.5 | 8.0 | 12.0 | Q1 |
| SN74AVC4T774RSVR | UQFN | RSV | 16 | 3000 | 178.0 | 13.5 | 2.1 | 2.9 | 0.75 | 4.0 | 12.0 | Q1 |

TAPE AND REEL BOX DIMENSIONS



*All dimensions are nominal

| Device | Package Type | Package Drawing | Pins | SPQ | Length (mm) | Width (mm) | Height (mm) |
|-------------------|--------------|-----------------|------|------|-------------|------------|-------------|
| 74AVC4T774RSVR-NT | UQFN | RSV | 16 | 3000 | 189.0 | 185.0 | 36.0 |
| SN74AVC4T774PWR | TSSOP | PW | 16 | 2000 | 356.0 | 356.0 | 35.0 |
| SN74AVC4T774RGYR | VQFN | RGY | 16 | 3000 | 356.0 | 356.0 | 35.0 |
| SN74AVC4T774RSVR | UQFN | RSV | 16 | 3000 | 189.0 | 185.0 | 36.0 |

TUBE

*All dimensions are nominal

| Device | Package Name | Package Type | Pins | SPQ | L (mm) | W (mm) | T (μm) | B (mm) |
|----------------|--------------|--------------|------|-----|--------|--------|--------|--------|
| SN74AVC4T774PW | PW | TSSOP | 16 | 90 | 530 | 10.2 | 3600 | 3.5 |

RGY (R-PVQFN-N16)

PLASTIC QUAD FLATPACK NO-LEAD



4203539-3/1 06/2011

- NOTES:
- All linear dimensions are in millimeters. Dimensioning and tolerancing per ASME Y14.5M-1994.
 - This drawing is subject to change without notice.
 - QFN (Quad Flatpack No-Lead) package configuration.
 - The package thermal pad must be soldered to the board for thermal and mechanical performance.
 - See the additional figure in the Product Data Sheet for details regarding the exposed thermal pad features and dimensions.
 - Pin 1 identifiers are located on both top and bottom of the package and within the zone indicated. The Pin 1 identifiers are either a molded, marked, or metal feature.
 - Package complies to JEDEC MO-241 variation BA.

RGY (R-PVQFN-N16)

PLASTIC QUAD FLATPACK NO-LEAD

THERMAL INFORMATION

This package incorporates an exposed thermal pad that is designed to be attached directly to an external heatsink. The thermal pad must be soldered directly to the printed circuit board (PCB). After soldering, the PCB can be used as a heatsink. In addition, through the use of thermal vias, the thermal pad can be attached directly to the appropriate copper plane shown in the electrical schematic for the device, or alternatively, can be attached to a special heatsink structure designed into the PCB. This design optimizes the heat transfer from the integrated circuit (IC).

For information on the Quad Flatpack No-Lead (QFN) package and its advantages, refer to Application Report, QFN/SON PCB Attachment, Texas Instruments Literature No. SLUA271. This document is available at www.ti.com.

The exposed thermal pad dimensions for this package are shown in the following illustration.



Bottom View

Exposed Thermal Pad Dimensions

4206353-3/P 03/14

NOTE: All linear dimensions are in millimeters

RGY (R-PVQFN-N16)

PLASTIC QUAD FLATPACK NO-LEAD



- NOTES:
- A. All linear dimensions are in millimeters.
 - B. This drawing is subject to change without notice.
 - C. Publication IPC-7351 is recommended for alternate designs.
 - D. This package is designed to be soldered to a thermal pad on the board. Refer to Application Note, Quad Flat-Pack QFN/SON PCB Attachment, Texas Instruments Literature No. SLUA271, and also the Product Data Sheets for specific thermal information, via requirements, and recommended board layout. These documents are available at www.ti.com <<http://www.ti.com>>.
 - E. Laser cutting apertures with trapezoidal walls and also rounding corners will offer better paste release. Customers should contact their board assembly site for stencil design recommendations. Refer to IPC 7525 for stencil design considerations.
 - F. Customers should contact their board fabrication site for minimum solder mask web tolerances between signal pads.

EXAMPLE BOARD LAYOUT

RSV0016A

UQFN - 0.55 mm max height

ULTRA THIN QUAD FLATPACK - NO LEAD

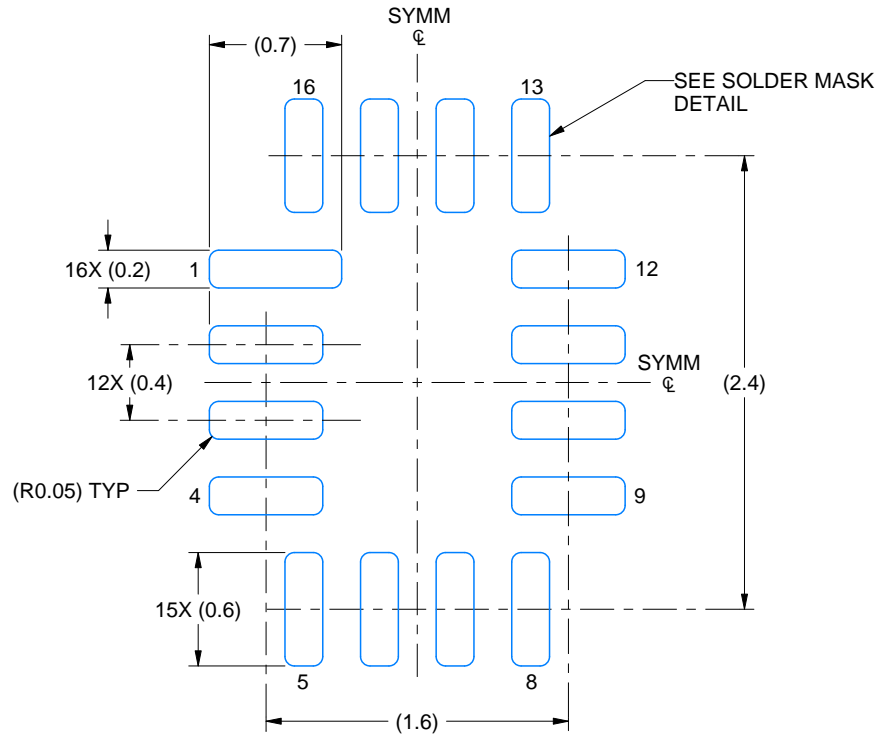

LAND PATTERN EXAMPLE
EXPOSED METAL SHOWN
SCALE: 25X

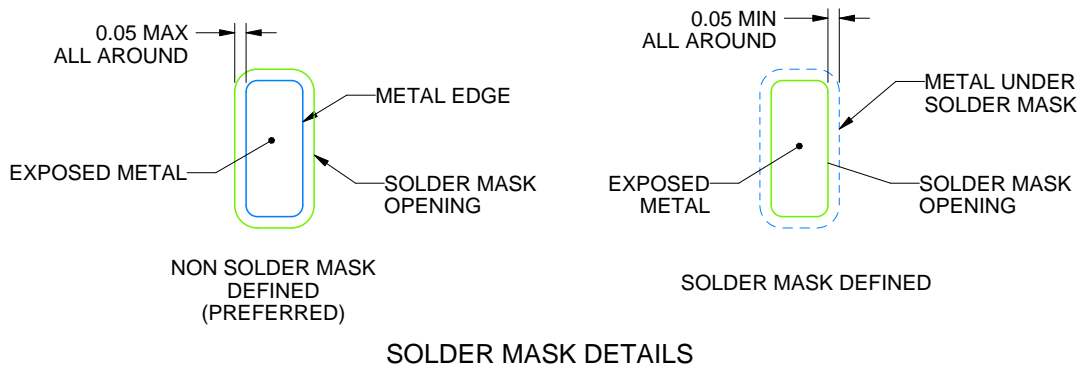

SOLDER MASK DETAILS

4220314/C 02/2020

NOTES: (continued)

3. For more information, see Texas Instruments literature number SLUA271 (www.ti.com/lit/slua271).

EXAMPLE STENCIL DESIGN

RSV0016A

UQFN - 0.55 mm max height

ULTRA THIN QUAD FLATPACK - NO LEAD

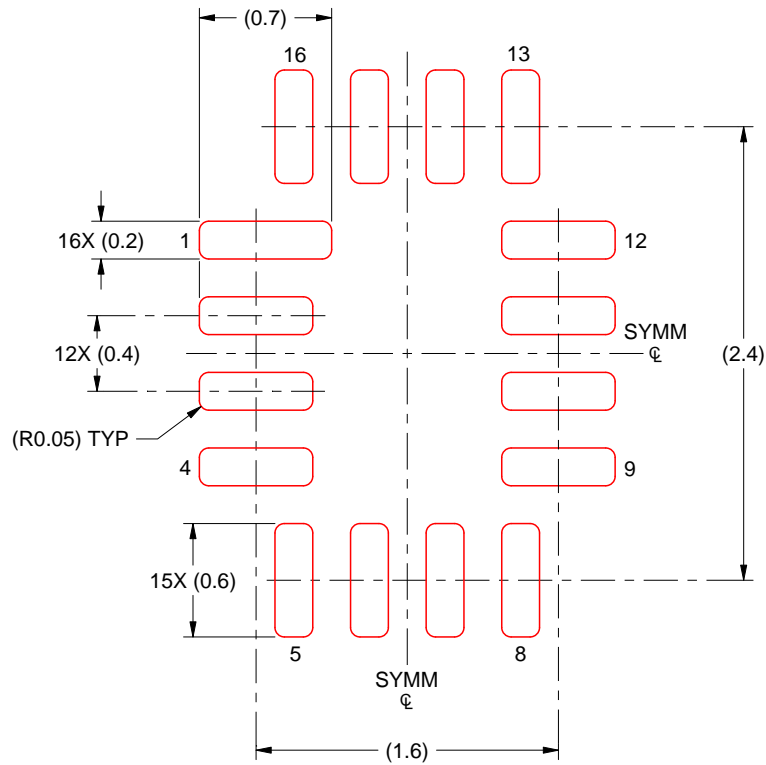

SOLDER PASTE EXAMPLE
BASED ON 0.125 MM THICK STENCIL
SCALE: 25X

4220314/C 02/2020

NOTES: (continued)

4. Laser cutting apertures with trapezoidal walls and rounded corners may offer better paste release. IPC-7525 may have alternate design recommendations.



4220204/A 02/2017

NOTES:

1. All linear dimensions are in millimeters. Any dimensions in parenthesis are for reference only. Dimensioning and tolerancing per ASME Y14.5M.
2. This drawing is subject to change without notice.
3. This dimension does not include mold flash, protrusions, or gate burrs. Mold flash, protrusions, or gate burrs shall not exceed 0.15 mm per side.
4. This dimension does not include interlead flash. Interlead flash shall not exceed 0.25 mm per side.
5. Reference JEDEC registration MO-153.

EXAMPLE BOARD LAYOUT

PW0016A

TSSOP - 1.2 mm max height

SMALL OUTLINE PACKAGE



LAND PATTERN EXAMPLE
EXPOSED METAL SHOWN
SCALE: 10X



4220204/A 02/2017

NOTES: (continued)

6. Publication IPC-7351 may have alternate designs.
7. Solder mask tolerances between and around signal pads can vary based on board fabrication site.

EXAMPLE STENCIL DESIGN

PW0016A

TSSOP - 1.2 mm max height

SMALL OUTLINE PACKAGE



SOLDER PASTE EXAMPLE
BASED ON 0.125 mm THICK STENCIL
SCALE: 10X

4220204/A 02/2017

NOTES: (continued)

8. Laser cutting apertures with trapezoidal walls and rounded corners may offer better paste release. IPC-7525 may have alternate design recommendations.
9. Board assembly site may have different recommendations for stencil design.

IMPORTANT NOTICE AND DISCLAIMER

TI PROVIDES TECHNICAL AND RELIABILITY DATA (INCLUDING DATA SHEETS), DESIGN RESOURCES (INCLUDING REFERENCE DESIGNS), APPLICATION OR OTHER DESIGN ADVICE, WEB TOOLS, SAFETY INFORMATION, AND OTHER RESOURCES "AS IS" AND WITH ALL FAULTS, AND DISCLAIMS ALL WARRANTIES, EXPRESS AND IMPLIED, INCLUDING WITHOUT LIMITATION ANY IMPLIED WARRANTIES OF MERCHANTABILITY, FITNESS FOR A PARTICULAR PURPOSE OR NON-INFRINGEMENT OF THIRD PARTY INTELLECTUAL PROPERTY RIGHTS.

These resources are intended for skilled developers designing with TI products. You are solely responsible for (1) selecting the appropriate TI products for your application, (2) designing, validating and testing your application, and (3) ensuring your application meets applicable standards, and any other safety, security, regulatory or other requirements.

These resources are subject to change without notice. TI grants you permission to use these resources only for development of an application that uses the TI products described in the resource. Other reproduction and display of these resources is prohibited. No license is granted to any other TI intellectual property right or to any third party intellectual property right. TI disclaims responsibility for, and you will fully indemnify TI and its representatives against, any claims, damages, costs, losses, and liabilities arising out of your use of these resources.

TI's products are provided subject to [TI's Terms of Sale](#) or other applicable terms available either on [ti.com](https://www.ti.com) or provided in conjunction with such TI products. TI's provision of these resources does not expand or otherwise alter TI's applicable warranties or warranty disclaimers for TI products.

TI objects to and rejects any additional or different terms you may have proposed.

Mailing Address: Texas Instruments, Post Office Box 655303, Dallas, Texas 75265
Copyright © 2024, Texas Instruments Incorporated

Looking for pricing, stock, or lifecycle information?

Click below to explore more details on WIN SOURCE:

⊖ [View SN74AVC4T774RSVR on WIN SOURCE](#)

⊖ [Texas Instruments](#) Information

Optimize Your Supply Chain with WIN SOURCE Solutions

- ✓ Global Sourcing Solution
- ✓ Obsolete Management
- ✓ Cost Control Management
- ✓ Shortage Management
- ✓ Alternative Solution
- ✓ Excess Inventory Management