



**THE DATASHEET OF  
SN74AVC4T245RGYR**



# SN74AVC4T245 Dual-Bit Bus Transceiver with Configurable Voltage Translation and 3-State Outputs

## 1 Features

- Control inputs  $V_{IH}/V_{IL}$  levels are referenced to  $V_{CCA}$  voltage
- Fully configurable dual-rail design allows each port to operate over the full 1.2V to 3.6V power-supply range
- I/Os Are 4.6V tolerant
- $I_{off}$  supports partial power-down-mode operation
- Maximum data rates:
  - 380Mbps (1.8V to 3.3V translation)
  - 200Mbps (< 1.8V to 3.3V translation)
  - 200Mbps (translate to 2.5V or 1.8V)
  - 150Mbps (translate to 1.5V)
  - 100Mbps (translate to 1.2V)
- Latch-up performance exceeds 100mA per JESD 78, Class II
- ESD protection exceeds JESD 22:
  - 8000V Human-Body Model (A114-A)
  - 150V Machine Model (A115-A)
  - 1000V Charged-Device Model (C101)

## 2 Applications

- [Personal electronics](#)
- [Industrial](#)
- [Enterprise](#)
- [Telecom](#)

## 3 Description

This 4-bit noninverting bus transceiver uses two separate configurable power-supply rails. The A port is designed to track  $V_{CCA}$ .  $V_{CCA}$  accepts any supply voltage from 1.2V to 3.6V. The B port is designed to track  $V_{CCB}$ .  $V_{CCB}$  accepts any supply voltage from 1.2V to 3.6V. The SN74AVC4T245 is optimized to operate with  $V_{CCA}/V_{CCB}$  set at 1.4V to 3.6V. It is operational with  $V_{CCA}/V_{CCB}$  as low as 1.2V. This allows for universal low-voltage bidirectional translation between any of the 1.2V, 1.5V, 1.8V, 2.5V, and 3.3V voltage nodes.

The SN74AVC4T245 device is designed for asynchronous communication between two data buses. The logic levels of the direction-control (DIR) input and the output-enable ( $\overline{OE}$ ) input activate either the B-port outputs or the A-port outputs or place both output ports into the high-impedance mode. The device transmits data from the A bus to the B bus when the B-port outputs are activated, and from the B bus to the A bus when the A-port outputs are activated. The input circuitry on both A and B ports is always active and must have a logic HIGH or LOW level applied to prevent excess  $I_{CC}$  and  $I_{CCZ}$ .

The SN74AVC4T245 device is designed so that  $V_{CCA}$  supplies the control pins (1DIR, 2DIR, 1  $\overline{OE}$ , and 2  $\overline{OE}$ ).

This device is fully specified for partial-power-down applications using  $I_{off}$ . The  $I_{off}$  circuitry disables the outputs, preventing damaging current backflow through the device when it is powered down.

The  $V_{CC}$  isolation feature is designed so that if either  $V_{CC}$  input is at GND, then both ports are in the high-impedance state.

To put the device in the high-impedance state during power up or power down, tie  $\overline{OE}$  to  $V_{CC}$  through a pullup resistor; the current-sinking capability of the driver determines the minimum value of the resistor.

### Package Information

| PART NUMBER  | PACKAGE <sup>(1)</sup> | PACKAGE SIZE <sup>(2)</sup> |
|--------------|------------------------|-----------------------------|
| SN74AVC4T245 | D (SOIC, 16)           | 9.9mm × 6mm                 |
|              | DGV (TVSOP, 16)        | 3.6mm × 6.4mm               |
|              | PW (TSSOP, 16)         | 5mm × 6.4mm                 |
|              | RGY (WQFN, 16)         | 4mm × 3.5mm                 |
|              | RSV (UQFN, 16)         | 2.6mm × 1.8mm               |
|              | BQB (WQFN, 16)         | 3.5mm × 2.5mm               |
|              | DYY (SOT, 16)          | 4.2mm × 2mm                 |

(1) For more information, see [Section 11](#).

(2) The package size (length × width) is a nominal value and includes pins, where applicable.





## Table of Contents

|   |    |  |    |
|---|----|--|----|
| <b>1 Features</b> .....   | 1  | 7.1 Overview.....  | 14 |
| <b>2 Applications</b> .....                                     | 1  | 7.2 Functional Block Diagram.....                                | 14 |
| <b>3 Description</b> .....                                      | 1  | 7.3 Feature Description.....                                     | 15 |
| <b>4 Pin Configuration and Functions</b> .....                  | 3  | 7.4 Device Functional Modes.....                                 | 15 |
| <b>5 Specifications</b> .....                                   | 5  | <b>8 Application and Implementation</b> .....                    | 16 |
| 5.1 Absolute Maximum Ratings.....                               | 5  | 8.1 Application Information.....                                 | 16 |
| 5.2 ESD Ratings.....  | 5  | 8.2 Typical Application.....                                     | 16 |
| 5.3 Recommended Operating Conditions.....                       | 6  | 8.3 Power Supply Recommendations.....                            | 17 |
| 5.4 Thermal Information.....                                    | 7  | 8.4 Layout.....  | 18 |
| 5.5 Electrical Characteristics.....                             | 8  | <b>9 Device and Documentation Support</b> .....                  | 19 |
| 5.6 Operating Characteristics.....                              | 9  | 9.1 Receiving Notification of Documentation Updates.....         | 19 |
| 5.7 Switching Characteristics: $V_{CCA} = 1.2V$ .....           | 9  | 9.2 Support Resources.....                                       | 19 |
| 5.8 Switching Characteristics: $V_{CCA} = 1.5V \pm 0.1V$ .....  | 10 | 9.3 Trademarks.....  | 19 |
| 5.9 Switching Characteristics: $V_{CCA} = 1.8V \pm 0.15V$ ..... | 10 | 9.4 Electrostatic Discharge Caution.....                         | 19 |
| 5.10 Switching Characteristics: $V_{CCA} = 2.5V \pm 0.2V$ ..... | 11 | 9.5 Glossary.....  | 19 |
| 5.11 Switching Characteristics: $V_{CCA} = 3.3V \pm 0.3V$ ..... | 11 | <b>10 Revision History</b> .....                                 | 19 |
| 5.12 Typical Characteristics.....                               | 12 | <b>11 Mechanical, Packaging, and Orderable Information</b> ..... | 20 |
| <b>6 Parameter Measurement Information</b> .....                | 13 |  |    |
| <b>7 Detailed Description</b> .....                             | 14 |  |    |

## 4 Pin Configuration and Functions

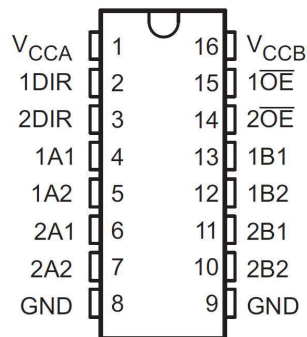


Figure 4-1. D, DGV, or PW Package, 16-Pin SOIC, TVSOP, or PW (Top View)

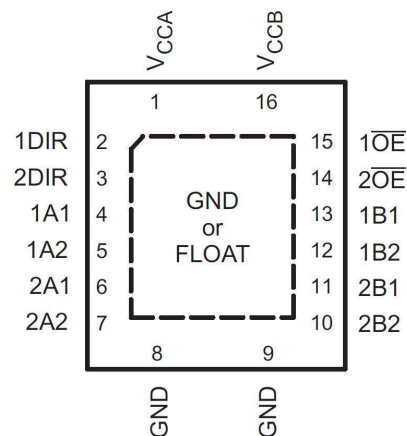


Figure 4-2. RGY Package, 16-Pin WQFN (Top View)

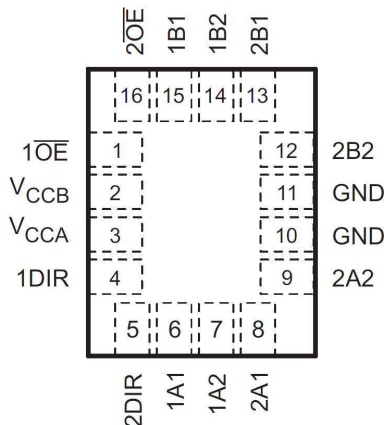


Figure 4-3. RSV Package, 16-Pin UQFN (Top View)

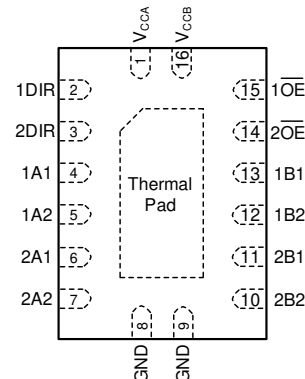


Figure 4-4. BQB/WBQB Package, 16-Pin WQFN (Transparent Top View)

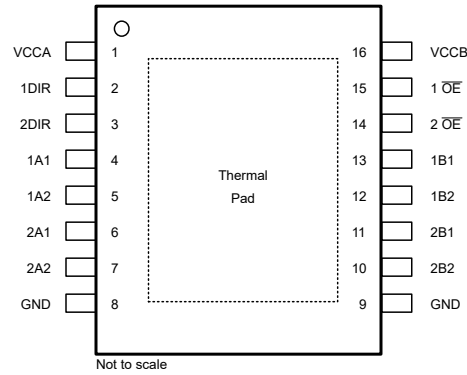


Figure 4-5. DYY Package, 16-Pin SOT (Top View)

Table 4-1. Pin Functions

| PIN<br>NAME       | NO.                |        | TYPE <sup>(1)</sup> | DESCRIPTION   |
|-------------------|--------------------|--------|---------------------|---|
|                   | D, DGV,<br>PW, RGY | RSV    |                     |   |
| 1A1               | 4                  | 6      | I/O                 | Input/output 1A1. Referenced to V <sub>CCA</sub> .  |
| 1A2               | 5                  | 7      | I/O                 | Input/output 1A2. Referenced to V <sub>CCA</sub> .  |
| 1B1               | 13                 | 15     | I/O                 | Input/output 1B1. Referenced to V <sub>CCB</sub> .  |
| 1B2               | 12                 | 14     | I/O                 | Input/output 1B2. Referenced to V <sub>CCB</sub> .  |
| 1DIR              | 2                  | 4      | I                   | Direction-control input for '1' ports   |
| 1 $\overline{OE}$ | 15                 | 1      | I                   | 3-state output-mode enables. Pull $\overline{OE}$ high to place '1' outputs in 3-state mode. Referenced to V <sub>CCA</sub> . |
| 2A1               | 6                  | 8      | I/O                 | Input/output 2A1. Referenced to V <sub>CCA</sub> .  |
| 2A2               | 7                  | 9      | I/O                 | Input/output 2A2. Referenced to V <sub>CCA</sub> .  |
| 2B1               | 11                 | 13     | I/O                 | Input/output 2B1. Referenced to V <sub>CCB</sub> .  |
| 2B2               | 10                 | 12     | I/O                 | Input/output 2B2. Referenced to V <sub>CCB</sub> .  |
| 2DIR              | 3                  | 5      | I                   | Direction-control input for '2' ports   |
| 2 $\overline{OE}$ | 14                 | 16     | I                   | 3-state output-mode enables. Pull $\overline{OE}$ high to place '2' outputs in 3-state mode. Referenced to V <sub>CCA</sub> . |
| GND               | 8, 9               | 10, 11 | —                   | Ground  |
| V <sub>CCA</sub>  | 1                  | 3      | —                   | A-port power supply voltage. $1.2V \leq V_{CCA} \leq 3.6V$  |
| V <sub>CCB</sub>  | 16                 | 2      | —                   | B-port power supply voltage. $1.2V \leq V_{CCB} \leq 3.6V$  |

(1) I = input, O = output

## 5 Specifications

### 5.1 Absolute Maximum Ratings

over operating free-air temperature range (unless otherwise noted)

|                                      |   |                    | MIN <sup>(1)</sup> | MAX                    | UNIT |
|--------------------------------------|---|--------------------|--------------------|------------------------|------|
| V <sub>CCA</sub><br>V <sub>CCB</sub> | Supply voltage range  |                    | -0.5               | 4.6                    | V    |
| V <sub>I</sub>                       | Input voltage range <sup>(2)</sup>  | I/O ports (A port) | -0.5               | 4.6                    | V    |
|                                      |   | I/O ports (B port) | -0.5               | 4.6                    |      |
|                                      |   | Control inputs     | -0.5               | 4.6                    |      |
| V <sub>O</sub>                       | Voltage range applied to any output in the high-impedance or power-off state <sup>(2)</sup> | A port             | -0.5               | 4.6                    | V    |
|                                      |   | B port             | -0.5               | 4.6                    |      |
| V <sub>O</sub>                       | Voltage range applied to any output in the high or low state <sup>(2) (3)</sup>             | A port             | -0.5               | V <sub>CCA</sub> + 0.5 | V    |
|                                      |   | B port             | -0.5               | V <sub>CCB</sub> + 0.5 |      |
| I <sub>IK</sub>                      | Input clamp current   | V <sub>I</sub> < 0 |                    | -50                    | mA   |
| I <sub>OK</sub>                      | Output clamp current  | V <sub>O</sub> < 0 |                    | -50                    | mA   |
| I <sub>O</sub>                       | Continuous output current   |                    |                    | ±50                    | mA   |
|                                      | Continuous current through V <sub>CCA</sub> , V <sub>CCB</sub> , or GND                     |                    |                    | ±100                   | mA   |

- (1) Stresses beyond those listed under *Absolute Maximum Ratings* may cause permanent damage to the device. These are stress ratings only, and functional operation of the device at these or any other conditions beyond those indicated under *Recommended Operating Conditions* is not implied. Exposure to absolute maximum rated conditions for extended periods may affect device reliability.
- (2) The input voltage and output negative-voltage ratings may be exceeded if the input and output current ratings are observed.
- (3) The output positive-voltage rating may be exceeded up to 4.6V maximum if the output current rating is observed.

### 5.2 ESD Ratings

|                    |                           |  | MIN | MAX | UNIT |
|--------------------|---------------------------|--|-----|-----|------|
| T <sub>stg</sub>   | Storage temperature range |  | -65 | 150 | °C   |
| V <sub>(ESD)</sub> | Electrostatic discharge   | Human body model (HBM), per ANSI/ESDA/JEDEC JS-001, all pins <sup>(1)</sup>              |     | 8   | kV   |
|                    |                           | Charged device model (CDM), per JEDEC specification JESD22-C101, all pins <sup>(2)</sup> |     | 1   |      |
|                    |                           | Machine model (C101)   |     | 150 | V    |

- (1) JEDEC document JEP155 states that 500V HBM allows safe manufacturing with a standard ESD control process.
- (2) JEDEC document JEP157 states that 250V CDM allows safe manufacturing with a standard ESD control process.

### 5.3 Recommended Operating Conditions

over operating free-air temperature range (unless otherwise noted)<sup>(1) (2) (3)</sup>

|                     |                                    | $V_{CCI}$                                     | $V_{CCO}$      | MIN                   | MAX       | UNIT |
|---------------------|------------------------------------|---|----------------|-----------------------|-----------|------|
| $V_{CCA}$           | Supply voltage                     |   |                | 1.2                   | 3.6       | V    |
| $V_{CCB}$           | Supply voltage                     |   |                | 1.2                   | 3.6       | V    |
| $V_{IH}$            | High-level input voltage           | Data inputs <sup>(4)</sup>                    | 1.2V to 1.95V  | $V_{CCI} \times 0.65$ |           | V    |
|                     |                                    |   | 1.95V to 2.7V  | 1.6                   |           |      |
|                     |                                    |   | 2.7V to 3.6V   | 2                     |           |      |
| $V_{IL}$            | Low-level input voltage            | Data inputs <sup>(4)</sup>                    | 1.2V to 1.95V  | $V_{CCI} \times 0.35$ |           | V    |
|                     |                                    |   | 1.95V to 2.7V  | 0.7                   |           |      |
|                     |                                    |   | 2.7V to 3.6V   | 0.8                   |           |      |
| $V_{IH}$            | High-level input voltage           | DIR (referenced to $V_{CCA}$ ) <sup>(5)</sup> | 1.2V to 1.95V  | $V_{CCA} \times 0.65$ |           | V    |
|                     |                                    |   | 1.95V to 2.7V  | 1.6                   |           |      |
|                     |                                    |   | 2.7V to 3.6V   | 2                     |           |      |
| $V_{IL}$            | Low-level input voltage            | DIR (referenced to $V_{CCA}$ ) <sup>(5)</sup> | 1.2V to 1.95V  | $V_{CCA} \times 0.35$ |           | V    |
|                     |                                    |   | 1.95V to 2.7V  | 0.7                   |           |      |
|                     |                                    |   | 2.7V to 3.6V   | 0.8                   |           |      |
| $V_I$               | Input voltage                      |   |                | 0                     | 3.6       | V    |
| $V_O$               | Output voltage                     | Active state                                  |                | 0                     | $V_{CCO}$ | V    |
|                     |                                    | 3-state                                       |                | 0                     | 3.6       |      |
| $I_{OH}$            | High-level output current          |   | 1.2V           | -3                    |           | mA   |
|                     |                                    |   | 1.4V to 1.6V   | -6                    |           |      |
|                     |                                    |   | 1.65V to 1.95V | -8                    |           |      |
|                     |                                    |   | 2.3V to 2.7V   | -9                    |           |      |
|                     |                                    |   | 3V to 3.6V     | -12                   |           |      |
| $I_{OL}$            | Low-level output current           |   | 1.1V to 1.2V   | 3                     |           | mA   |
|                     |                                    |   | 1.4V to 1.6V   | 6                     |           |      |
|                     |                                    |   | 1.65V to 1.95V | 8                     |           |      |
|                     |                                    |   | 2.3V to 2.7V   | 9                     |           |      |
|                     |                                    |   | 3V to 3.6V     | 12                    |           |      |
| $\Delta t/\Delta v$ | Input transition rise or fall rate |   |                |                       | 5         | ns/V |
| $T_A$               | Operating free-air temperature     |   |                | -40                   | 85        | °C   |

(1)  $V_{CCI}$  is the  $V_{CC}$  associated with the input port.

(2)  $V_{CCO}$  is the  $V_{CC}$  associated with the output port.

(3) All unused data inputs of the device must be held at  $V_{CCI}$  or GND for proper device operation. Refer to the [Implications of Slow or Floating CMOS Inputs](#) application report.

(4) For  $V_{CCI}$  values not specified in the data sheet,  $V_{IH}$  min =  $V_{CCI} \times 0.7V$ ,  $V_{IL}$  max =  $V_{CCI} \times 0.3V$

(5) For  $V_{CCI}$  values not specified in the data sheet,  $V_{IH}$  min =  $V_{CCA} \times 0.7V$ ,  $V_{IL}$  max =  $V_{CCA} \times 0.3V$

## 5.4 Thermal Information

| THERMAL METRIC <sup>(1)</sup>                                     | SN74AVC4T245 |      |       |       |       |      |       | UNIT |
|---|--------------|------|-------|-------|-------|------|-------|------|
|   | D            | BQB  | DYY   | DGV   | PW    | RGY  | RSV   |      |
|   | 16 PINS      |      |       |       |       |      |       |      |
| $R_{\theta JA}$ Junction-to-ambient thermal resistance            | 85.5         | 80.8 | 163.4 | 126.0 | 101.8 | 37.5 | 146.9 | °C/W |
| $R_{\theta JC(top)}$ Junction-to-case (top) thermal resistance    | 46.9         | 77.9 | 90.0  | 50.8  | 37.2  | 54.5 | 53.6  |      |
| $R_{\theta JB}$ Junction-to-board thermal resistance              | 43.0         | 50.7 | 93.1  | 57.7  | 60.6  | 15.6 | 75.6  |      |
| $\Psi_{JT}$ Junction-to-top characterization parameter            | 13.4         | 7.4  | 10.9  | 5.7   | 1.6   | 0.5  | 13.5  |      |
| $\Psi_{JB}$ Junction-to-board characterization parameter          | 42.7         | 50.6 | 92.1  | 57.2  | 60.0  | 15.8 | 75.6  |      |
| $R_{\theta JC(bot)}$ Junction-to-case (bottom) thermal resistance | —            | 28.4 | —     | —     | —     | 3.5  | —     |      |

(1) For more information about traditional and new thermal metrics, see the *IC Package Thermal Metrics* application report ([SPRA953](#)).

## 5.5 Electrical Characteristics

over recommended operating free-air temperature range (unless otherwise noted)

| PARAMETER <sup>(1)</sup><br>(2)     | TEST CONDITIONS |   | V <sub>CCA</sub>                 | V <sub>CCB</sub> | T <sub>A</sub> = 25°C |       |      | –40°C to 85°C |                        | UNIT |
|-------------------------------------|-----------------|---|----------------------------------|------------------|-----------------------|-------|------|---------------|------------------------|------|
|                                     |                 |   |                                  |                  | MIN                   | TYP   | MAX  | MIN           | MAX                    |      |
| V <sub>OH</sub>                     |                 | I <sub>OH</sub> = –100μA<br>I <sub>OH</sub> = –3mA<br>I <sub>OH</sub> = –6mA<br>I <sub>OH</sub> = –8mA<br>I <sub>OH</sub> = –9mA<br>I <sub>OH</sub> = –12mA | V <sub>I</sub> = V <sub>IH</sub> | 1.2V to 3.6V     | 1.2V to 3.6V          |       |      |               | V <sub>CCO</sub> – 0.2 | V    |
|                                     |                 |   |                                  | 1.2V             | 1.2V                  | 0.95  |      |               |                        |      |
|                                     |                 |   |                                  | 1.4V             | 1.4V                  |       | 1.05 |               |                        |      |
|                                     |                 |   |                                  | 1.65V            | 1.65V                 |       | 1.2  |               |                        |      |
|                                     |                 |   |                                  | 2.3V             | 2.3V                  |       | 1.75 |               |                        |      |
|                                     |                 |   |                                  | 3V               | 3V                    |       | 2.3  |               |                        |      |
| V <sub>OL</sub>                     |                 | I <sub>OL</sub> = 100μA<br>I <sub>OL</sub> = 3mA<br>I <sub>OL</sub> = 6mA<br>I <sub>OL</sub> = 8mA<br>I <sub>OL</sub> = 9mA<br>I <sub>OL</sub> = 12mA       | V <sub>I</sub> = V <sub>IL</sub> | 1.2V to 3.6V     | 1.2V to 3.6V          |       |      |               | 0.2                    | V    |
|                                     |                 |   |                                  | 1.2V             | 1.2V                  | 0.25  |      |               |                        |      |
|                                     |                 |   |                                  | 1.4V             | 1.4V                  |       | 0.35 |               |                        |      |
|                                     |                 |   |                                  | 1.65V            | 1.65V                 |       | 0.45 |               |                        |      |
|                                     |                 |   |                                  | 2.3V             | 2.3V                  |       | 0.55 |               |                        |      |
|                                     |                 |   |                                  | 3V               | 3V                    |       | 0.7  |               |                        |      |
| I <sub>I</sub>                      | Control inputs  | V <sub>I</sub> = V <sub>CCA</sub> or GND  | 1.2V to 3.6V                     | 1.2V to 3.6V     | ±0.025                | ±0.25 |      |               | ±1                     | μA   |
| I <sub>off</sub>                    | A or B port     | V <sub>I</sub> or V <sub>O</sub> = 0 to 3.6V  | 0V                               | 0V to 3.6V       | ±0.1                  | ±1    |      |               | ±5                     | μA   |
|                                     |                 |   | 0V to 3.6V                       | 0V               | ±0.1                  | ±1    |      | ±5            |                        |      |
| I <sub>OZ</sub>                     | A or B port     | V <sub>O</sub> = V <sub>CCO</sub> or GND,<br>V <sub>I</sub> = V <sub>CCI</sub> or GND, $\overline{OE}$ = V <sub>IH</sub>                                    | 3.6V                             | 3.6V             | ±0.5                  | ±2.5  |      |               | ±5                     | μA   |
| I <sub>CCA</sub>                    |                 | V <sub>I</sub> = V <sub>CCI</sub> or GND, I <sub>O</sub> = 0  | 1.2V to 3.6V                     | 1.2V to 3.6V     |                       |       |      |               | 8                      | μA   |
|                                     |                 |   | 0V                               | 0V to 3.6V       |                       |       |      | –2            |                        |      |
|                                     |                 |   | 0V to 3.6V                       | 0V               |                       |       |      | 8             |                        |      |
| I <sub>CCB</sub>                    |                 | V <sub>I</sub> = V <sub>CCI</sub> or GND, I <sub>O</sub> = 0  | 1.2V to 3.6V                     | 1.2V to 3.6V     |                       |       |      |               | 8                      | μA   |
|                                     |                 |   | 0V                               | 0V to 3.6V       |                       |       |      | 8             |                        |      |
|                                     |                 |   | 0V to 3.6V                       | 0V               |                       |       |      | –2            |                        |      |
| I <sub>CCA</sub> + I <sub>CCB</sub> |                 | V <sub>I</sub> = V <sub>CCI</sub> or GND, I <sub>O</sub> = 0  | 1.2V to 3.6V                     | 1.2V to 3.6V     |                       |       |      |               | 16                     | μA   |
| C <sub>i</sub>                      | Control inputs  | V <sub>I</sub> = 3.3V or GND  | 3.3V                             | 3.3V             | 3.5                   |       |      |               | 4.5                    | pF   |
| C <sub>io</sub>                     | A or B port     | V <sub>O</sub> = 3.3V or GND  | 3.3V                             | 3.3V             | 6                     |       |      |               | 7                      | pF   |

(1) V<sub>CCI</sub> is the V<sub>CC</sub> associated with the input port.

(2) V<sub>CCO</sub> is the V<sub>CC</sub> associated with the output port.

## 5.6 Operating Characteristics

T<sub>A</sub> = 25°C

| PARAMETER                       |        |                  | TEST CONDITIONS  | V <sub>CCA</sub> =<br>V <sub>CCB</sub> = 1.2V | V <sub>CCA</sub> =<br>V <sub>CCB</sub> = 1.5V | V <sub>CCA</sub> =<br>V <sub>CCB</sub> = 1.8V | V <sub>CCA</sub> =<br>V <sub>CCB</sub> = 2.5V | V <sub>CCA</sub> =<br>V <sub>CCB</sub> = 3.3V | UNIT |
|---------------------------------|--------|------------------|--|---|---|---|---|---|------|
|                                 |        |                  |  | TYP   | TYP   | TYP   | TYP   | TYP   |      |
| C <sub>pdA</sub> <sup>(1)</sup> | A to B | Outputs enabled  | C <sub>L</sub> = 0,<br>f = 10MHz,<br>t <sub>r</sub> = t <sub>f</sub> = 1ns | 1   | 1   | 1   | 1.5   | 2   | pF   |
|                                 |        | Outputs disabled |  | 1   | 1   | 1   | 1   | 1   |      |
|                                 | B to A | Outputs enabled  |  | 12  | 12.5  | 13  | 14  | 15  |      |
|                                 |        | Outputs disabled |  | 1   | 1   | 1   | 1   | 1   |      |
| C <sub>pdB</sub> <sup>(1)</sup> | A to B | Outputs enabled  | C <sub>L</sub> = 0,<br>f = 10MHz,<br>t <sub>r</sub> = t <sub>f</sub> = 1ns | 12  | 12.5  | 13  | 14  | 15  | pF   |
|                                 |        | Outputs disabled |  | 1   | 1   | 1   | 1   | 1   |      |
|                                 | B to A | Outputs enabled  |  | 1   | 1   | 1   | 1   | 2   |      |
|                                 |        | Outputs disabled |  | 1   | 1   | 1   | 1   | 1   |      |

(1) Power dissipation capacitance per transceiver

## 5.7 Switching Characteristics: V<sub>CCA</sub> = 1.2V

over recommended operating free-air temperature range, V<sub>CCA</sub> = 1.2V (unless otherwise noted) (see [Figure 6-1](#))

| PARAMETER        | FROM<br>(INPUT) | TO<br>(OUTPUT) | V <sub>CCB</sub> = 1.2V | V <sub>CCB</sub> = 1.5V<br>± 0.1V | V <sub>CCB</sub> = 1.8V<br>± 0.15V | V <sub>CCB</sub> = 2.5V<br>± 0.2V | V <sub>CCB</sub> = 3.3V<br>± 0.3V | UNIT |
|------------------|-----------------|----------------|-------------------------|-----------------------------------|------------------------------------|-----------------------------------|-----------------------------------|------|
|                  |                 |                | TYP                     | TYP                               | TYP                                | TYP                               | TYP                               |      |
| t <sub>PLH</sub> | A               | B              | 3.4                     | 2.9                               | 2.7                                | 2.6                               | 2.8                               | ns   |
| t <sub>PHL</sub> |                 |                | 3.4                     | 2.9                               | 2.7                                | 2.6                               | 2.8                               |      |
| t <sub>PLH</sub> | B               | A              | 3.6                     | 3.1                               | 2.8                                | 2.6                               | 2.6                               | ns   |
| t <sub>PHL</sub> |                 |                | 3.6                     | 3.1                               | 2.8                                | 2.6                               | 2.6                               |      |
| t <sub>PZH</sub> | OE              | A              | 5.6                     | 4.7                               | 4.3                                | 3.9                               | 3.7                               | ns   |
| t <sub>PZL</sub> |                 |                | 5.6                     | 4.7                               | 4.3                                | 3.9                               | 3.7                               |      |
| t <sub>PZH</sub> | OE              | B              | 5                       | 4.3                               | 3.9                                | 3.6                               | 3.6                               | ns   |
| t <sub>PZL</sub> |                 |                | 5                       | 4.3                               | 3.9                                | 3.6                               | 3.6                               |      |
| t <sub>PHZ</sub> | OE              | A              | 6.2                     | 5.2                               | 5.2                                | 4.3                               | 4.8                               | ns   |
| t <sub>PLZ</sub> |                 |                | 6.2                     | 5.2                               | 5.2                                | 4.3                               | 4.8                               |      |
| t <sub>PHZ</sub> | OE              | B              | 5.9                     | 5.1                               | 5                                  | 4.7                               | 5.5                               | ns   |
| t <sub>PLZ</sub> |                 |                | 5.9                     | 5.1                               | 5                                  | 4.7                               | 5.5                               |      |

### 5.8 Switching Characteristics: $V_{CCA} = 1.5V \pm 0.1V$

over recommended operating free-air temperature range,  $V_{CCA} = 1.5V \pm 0.1V$  (see [Figure 6-1](#))

| PARAMETER | FROM (INPUT)    | TO (OUTPUT) | $V_{CCB} = 1.2V$ | $V_{CCB} = 1.5V \pm 0.1V$ |      | $V_{CCB} = 1.8V \pm 0.15V$ |      | $V_{CCB} = 2.5V \pm 0.2V$ |      | $V_{CCB} = 3.3V \pm 0.3V$ |      | UNIT |
|-----------|-----------------|-------------|------------------|---------------------------|------|----------------------------|------|---------------------------|------|---------------------------|------|------|
|           |                 |             | TYP              | MIN                       | MAX  | MIN                        | MAX  | MIN                       | MAX  | MIN                       | MAX  |      |
| $t_{PLH}$ | A               | B           | 3.2              | 0.3                       | 6.3  | 0.3                        | 5.2  | 0.4                       | 4.2  | 0.4                       | 4.2  | ns   |
| $t_{PHL}$ |                 |             | 3.2              | 0.3                       | 6.3  | 0.3                        | 5.2  | 0.4                       | 4.2  | 0.4                       | 4.2  |      |
| $t_{PLH}$ | B               | A           | 3.3              | 0.7                       | 6.3  | 0.5                        | 6    | 0.4                       | 5.7  | 0.3                       | 5.6  | ns   |
| $t_{PHL}$ |                 |             | 3.3              | 0.7                       | 6.3  | 0.5                        | 6    | 0.4                       | 5.7  | 0.3                       | 5.6  |      |
| $t_{PZH}$ | $\overline{OE}$ | A           | 4.9              | 1.4                       | 9.6  | 1.1                        | 9.5  | 0.7                       | 9.4  | 0.4                       | 9.4  | ns   |
| $t_{PZL}$ |                 |             | 4.9              | 1.4                       | 9.6  | 1.1                        | 9.5  | 0.7                       | 9.4  | 0.4                       | 9.4  |      |
| $t_{PZH}$ | $\overline{OE}$ | B           | 4.5              | 1.4                       | 9.6  | 1.1                        | 7.7  | 0.9                       | 5.8  | 0.9                       | 5.6  | ns   |
| $t_{PZL}$ |                 |             | 4.5              | 1.4                       | 9.6  | 1.1                        | 7.7  | 0.9                       | 5.8  | 0.9                       | 5.6  |      |
| $t_{PHZ}$ | $\overline{OE}$ | A           | 5.6              | 1.8                       | 10.2 | 1.5                        | 10.2 | 1.3                       | 10.2 | 1.6                       | 10.2 | ns   |
| $t_{PLZ}$ |                 |             | 5.6              | 1.8                       | 10.2 | 1.5                        | 10.2 | 1.3                       | 10.2 | 1.6                       | 10.2 |      |
| $t_{PHZ}$ | $\overline{OE}$ | B           | 5.2              | 1.9                       | 10.3 | 1.9                        | 9.1  | 1.4                       | 7.4  | 1.2                       | 7.6  | ns   |
| $t_{PLZ}$ |                 |             | 5.2              | 1.9                       | 10.3 | 1.9                        | 9.1  | 1.4                       | 7.4  | 1.2                       | 7.6  |      |

### 5.9 Switching Characteristics: $V_{CCA} = 1.8V \pm 0.15V$

over recommended operating free-air temperature range,  $V_{CCA} = 1.8V \pm 0.15V$  (see [Figure 6-1](#))

| PARAMETER | FROM (INPUT)    | TO (OUTPUT) | $V_{CCB} = 1.2V$ | $V_{CCB} = 1.5V \pm 0.1V$ |     | $V_{CCB} = 1.8V \pm 0.15V$ |     | $V_{CCB} = 2.5V \pm 0.2V$ |     | $V_{CCB} = 3.3V \pm 0.3V$ |     | UNIT |
|-----------|-----------------|-------------|------------------|---------------------------|-----|----------------------------|-----|---------------------------|-----|---------------------------|-----|------|
|           |                 |             | TYP              | MIN                       | MAX | MIN                        | MAX | MIN                       | MAX | MIN                       | MAX |      |
| $t_{PLH}$ | A               | B           | 2.9              | 0.1                       | 6   | 0.1                        | 4.9 | 0.1                       | 3.9 | 0.3                       | 3.9 | ns   |
| $t_{PHL}$ |                 |             | 2.9              | 0.1                       | 6   | 0.1                        | 4.9 | 0.1                       | 3.9 | 0.3                       | 3.9 |      |
| $t_{PLH}$ | B               | A           | 3                | 0.6                       | 5.3 | 0.5                        | 4.9 | 0.3                       | 4.6 | 0.3                       | 4.5 | ns   |
| $t_{PHL}$ |                 |             | 3                | 0.6                       | 5.3 | 0.5                        | 4.9 | 0.3                       | 4.6 | 0.3                       | 4.5 |      |
| $t_{PZH}$ | $\overline{OE}$ | A           | 4.4              | 1                         | 7.4 | 1                          | 7.3 | 0.6                       | 7.3 | 0.4                       | 7.2 | ns   |
| $t_{PZL}$ |                 |             | 4.4              | 1                         | 7.4 | 1                          | 7.3 | 0.6                       | 7.3 | 0.4                       | 7.2 |      |
| $t_{PZH}$ | $\overline{OE}$ | B           | 4.1              | 1.2                       | 9.2 | 1                          | 7.4 | 0.8                       | 5.3 | 0.8                       | 4.6 | ns   |
| $t_{PZL}$ |                 |             | 4.1              | 1.2                       | 9.2 | 1                          | 7.4 | 0.8                       | 5.3 | 0.8                       | 4.6 |      |
| $t_{PHZ}$ | $\overline{OE}$ | A           | 5.4              | 1.6                       | 8.6 | 1.8                        | 8.7 | 1.3                       | 8.7 | 1.6                       | 8.7 | ns   |
| $t_{PLZ}$ |                 |             | 5.4              | 1.6                       | 8.6 | 1.8                        | 8.7 | 1.3                       | 8.7 | 1.6                       | 8.7 |      |
| $t_{PHZ}$ | $\overline{OE}$ | B           | 5                | 1.7                       | 9.9 | 1.6                        | 8.7 | 1.2                       | 6.9 | 1                         | 6.9 | ns   |
| $t_{PLZ}$ |                 |             | 5                | 1.7                       | 9.9 | 1.6                        | 8.7 | 1.2                       | 6.9 | 1                         | 6.9 |      |

### 5.10 Switching Characteristics: $V_{CCA} = 2.5V \pm 0.2V$

over recommended operating free-air temperature range,  $V_{CCA} = 2.5V \pm 0.2V$  (see [Figure 6-1](#))

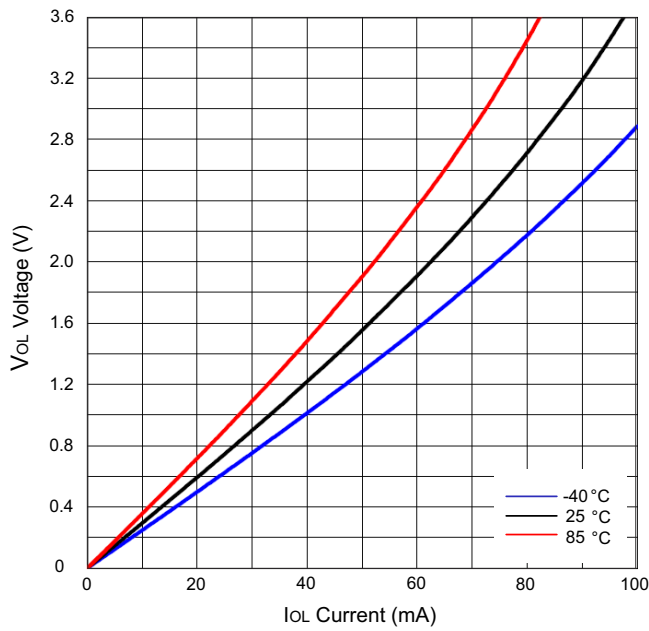
| PARAMETER | FROM (INPUT)    | TO (OUTPUT) | $V_{CCB} = 1.2V$ |     | $V_{CCB} = 1.5V \pm 0.1V$ |     | $V_{CCB} = 1.8V \pm 0.15V$ |     | $V_{CCB} = 2.5V \pm 0.2V$ |     | $V_{CCB} = 3.3V \pm 0.3V$ |     | UNIT |
|-----------|-----------------|-------------|------------------|-----|---------------------------|-----|----------------------------|-----|---------------------------|-----|---------------------------|-----|------|
|           |                 |             | TYP              | MIN | MAX                       | MIN | MAX                        | MIN | MAX                       | MIN | MAX                       | MIN |      |
| $t_{PLH}$ | A               | B           | 2.8              | 0.1 | 5.7                       | 0.1 | 4.6                        | 0.2 | 3.5                       | 0.1 | 3.6                       | ns  |      |
| $t_{PHL}$ |                 |             | 2.8              | 0.1 | 5.7                       | 0.1 | 4.6                        | 0.2 | 3.5                       | 0.1 | 3.6                       |     |      |
| $t_{PLH}$ | B               | A           | 2.7              | 0.6 | 4.2                       | 0.4 | 3.9                        | 0.2 | 3.4                       | 0.2 | 3.3                       | ns  |      |
| $t_{PHL}$ |                 |             | 2.7              | 0.6 | 4.2                       | 0.4 | 3.9                        | 0.2 | 3.4                       | 0.2 | 3.3                       |     |      |
| $t_{PZH}$ | $\overline{OE}$ | A           | 4                | 0.7 | 6.5                       | 0.7 | 5.2                        | 0.6 | 4.8                       | 0.4 | 4.8                       | ns  |      |
| $t_{PZL}$ |                 |             | 4                | 0.7 | 6.5                       | 0.7 | 5.2                        | 0.6 | 4.8                       | 0.4 | 4.8                       |     |      |
| $t_{PZH}$ | $\overline{OE}$ | B           | 3.8              | 0.9 | 8.8                       | 0.8 | 7                          | 0.6 | 4.8                       | 0.6 | 4                         | ns  |      |
| $t_{PZL}$ |                 |             | 3.8              | 0.9 | 8.8                       | 0.8 | 7                          | 0.6 | 4.8                       | 0.6 | 4                         |     |      |
| $t_{PHZ}$ | $\overline{OE}$ | A           | 4.7              | 1   | 8.4                       | 1   | 8.4                        | 1   | 6.2                       | 1   | 6.6                       | ns  |      |
| $t_{PLZ}$ |                 |             | 4.7              | 1   | 8.4                       | 1   | 8.4                        | 1   | 6.2                       | 1   | 6.6                       |     |      |
| $t_{PHZ}$ | $\overline{OE}$ | B           | 4.5              | 1.5 | 9.4                       | 1.3 | 8.2                        | 1.1 | 6.2                       | 0.9 | 5.2                       | ns  |      |
| $t_{PLZ}$ |                 |             | 4.5              | 1.5 | 9.4                       | 1.3 | 8.2                        | 1.1 | 6.2                       | 0.9 | 5.2                       |     |      |

### 5.11 Switching Characteristics: $V_{CCA} = 3.3V \pm 0.3V$

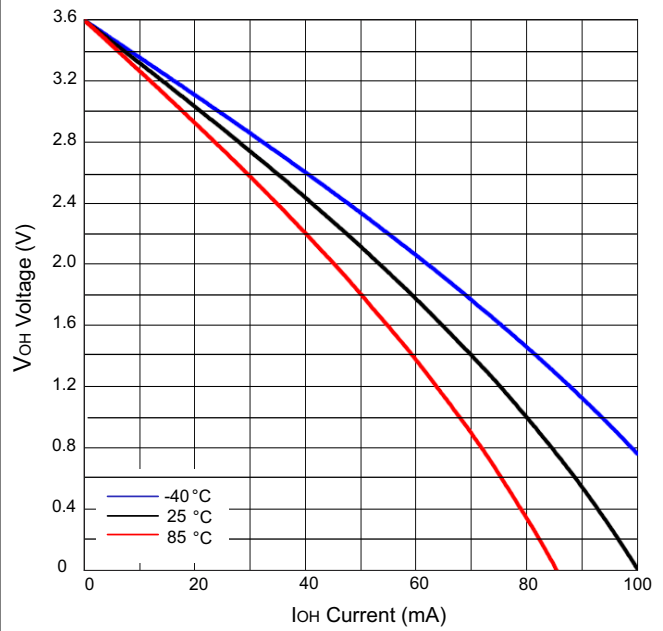
over recommended operating free-air temperature range,  $V_{CCA} = 3.3V \pm 0.3V$  (see [Figure 6-1](#))

| PARAMETER | FROM (INPUT)    | TO (OUTPUT) | $V_{CCB} = 1.2V$ |     | $V_{CCB} = 1.5V \pm 0.1V$ |     | $V_{CCB} = 1.8V \pm 0.15V$ |     | $V_{CCB} = 2.5V \pm 0.2V$ |     | $V_{CCB} = 3.3V \pm 0.3V$ |     | UNIT |
|-----------|-----------------|-------------|------------------|-----|---------------------------|-----|----------------------------|-----|---------------------------|-----|---------------------------|-----|------|
|           |                 |             | TYP              | MIN | MAX                       | MIN | MAX                        | MIN | MAX                       | MIN | MAX                       | MIN |      |
| $t_{PLH}$ | A               | B           | 2.9              | 0.1 | 5.6                       | 0.1 | 4.5                        | 0.1 | 3.3                       | 0.1 | 2.9                       | ns  |      |
| $t_{PHL}$ |                 |             | 2.9              | 0.1 | 5.6                       | 0.1 | 4.5                        | 0.1 | 3.3                       | 0.1 | 2.9                       |     |      |
| $t_{PLH}$ | B               | A           | 2.6              | 0.6 | 4.2                       | 0.4 | 3.4                        | 0.2 | 3                         | 0.1 | 2.8                       | ns  |      |
| $t_{PHL}$ |                 |             | 2.6              | 0.6 | 4.2                       | 0.4 | 3.4                        | 0.2 | 3                         | 0.1 | 2.8                       |     |      |
| $t_{PZH}$ | $\overline{OE}$ | A           | 3.8              | 0.6 | 8.7                       | 0.6 | 5.2                        | 0.6 | 3.8                       | 0.4 | 3.8                       | ns  |      |
| $t_{PZL}$ |                 |             | 3.8              | 0.6 | 8.7                       | 0.6 | 5.2                        | 0.6 | 3.8                       | 0.4 | 3.8                       |     |      |
| $t_{PZH}$ | $\overline{OE}$ | B           | 3.7              | 0.8 | 8.7                       | 0.6 | 6.8                        | 0.5 | 4.7                       | 0.5 | 3.8                       | ns  |      |
| $t_{PZL}$ |                 |             | 3.7              | 0.8 | 8.7                       | 0.6 | 6.8                        | 0.5 | 4.7                       | 0.5 | 3.8                       |     |      |
| $t_{PHZ}$ | $\overline{OE}$ | A           | 4.8              | 0.7 | 9.3                       | 0.7 | 8.3                        | 0.7 | 5.6                       | 0.7 | 6.6                       | ns  |      |
| $t_{PLZ}$ |                 |             | 4.8              | 0.7 | 9.3                       | 0.7 | 8.3                        | 0.7 | 5.6                       | 0.7 | 6.6                       |     |      |
| $t_{PHZ}$ | $\overline{OE}$ | B           | 5.3              | 1.4 | 9.3                       | 1.2 | 8.1                        | 1   | 6.4                       | 0.8 | 6.2                       | ns  |      |
| $t_{PLZ}$ |                 |             | 5.3              | 1.4 | 9.3                       | 1.2 | 8.1                        | 1   | 6.4                       | 0.8 | 6.2                       |     |      |

## 5.12 Typical Characteristics

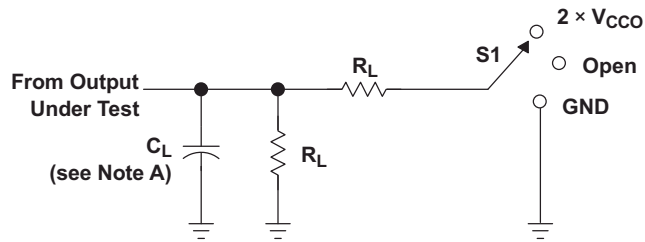


**Figure 5-1. Low-Level Output Voltage ( $V_{OL}$ ) vs Low-Level Current ( $I_{OL}$ )**



**Figure 5-2. High-Level Output Voltage ( $V_{OH}$ ) vs High-Level Current ( $I_{OH}$ )**

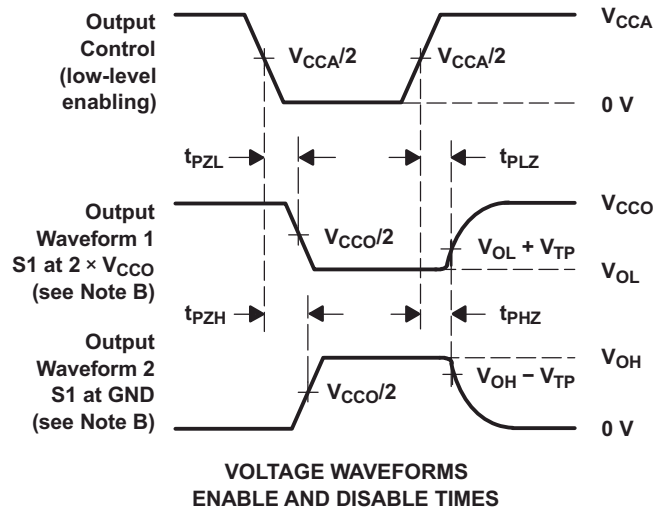
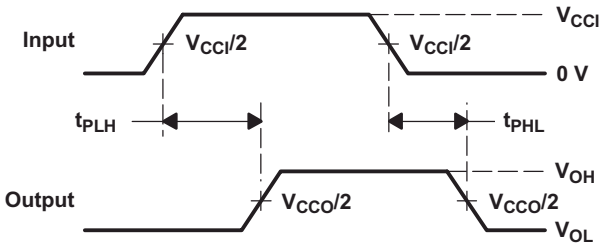
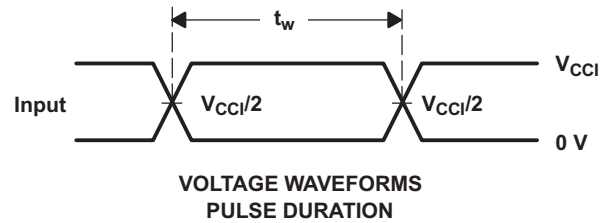
## 6 Parameter Measurement Information



LOAD CIRCUIT

| $V_{CCO}$          | $C_L$ | $R_L$        | $V_{TP}$ |
|--------------------|-------|--------------|----------|
| 1.2 V              | 15 pF | 2 k $\Omega$ | 0.1 V    |
| 1.5 V $\pm$ 0.1 V  | 15 pF | 2 k $\Omega$ | 0.1 V    |
| 1.8 V $\pm$ 0.15 V | 15 pF | 2 k $\Omega$ | 0.15 V   |
| 2.5 V $\pm$ 0.2 V  | 15 pF | 2 k $\Omega$ | 0.15 V   |
| 3.3 V $\pm$ 0.3 V  | 15 pF | 2 k $\Omega$ | 0.3 V    |

| TEST              | S1                 |
|-------------------|--------------------|
| $t_{pd}$          | Open               |
| $t_{PLZ}/t_{PZL}$ | $2 \times V_{CCO}$ |
| $t_{PHZ}/t_{PZH}$ | GND                |



- NOTES:
- $C_L$  includes probe and jig capacitance.
  - Waveform 1 is for an output with internal conditions such that the output is low, except when disabled by the output control. Waveform 2 is for an output with internal conditions such that the output is high, except when disabled by the output control.
  - All input pulses are supplied by generators having the following characteristics: PRR = 10 MHz,  $Z_O = 50 \Omega$ ,  $dv/dt \geq 1$  V/ns.
  - The outputs are measured one at a time, with one transition per measurement.
  - $t_{PLZ}$  and  $t_{PHZ}$  are the same as  $t_{dis}$ .
  - $t_{PZL}$  and  $t_{PZH}$  are the same as  $t_{en}$ .
  - $t_{PLH}$  and  $t_{PHL}$  are the same as  $t_{pd}$ .
  - $V_{CCi}$  is the  $V_{CC}$  associated with the input port.
  - $V_{CCo}$  is the  $V_{CC}$  associated with the output port.

Figure 6-1. Load and Circuit and Voltage Waveforms

## 7 Detailed Description

### 7.1 Overview

The SN74AVC4T245 is a 4-bit, dual-supply noninverting bidirectional voltage level translation device.  $V_{CCA}$  supports the Ax pins and control pins (1DIR, 2DIR, 1  $\overline{OE}$ , and 2  $\overline{OE}$ ), and  $V_{CCB}$  supports the Bx pins. The A port can accept I/O voltages ranging from 1.2V to 3.6V, while the B port can accept I/O voltages from 1.2V to 3.6V. A high on DIR allows data transmission from Ax to Bx and a low on DIR allows data transmission from Bx to Ax when  $\overline{OE}$  is set to low. When  $\overline{OE}$  is set to high, both Ax and Bx pins are in the high-impedance state.

### 7.2 Functional Block Diagram

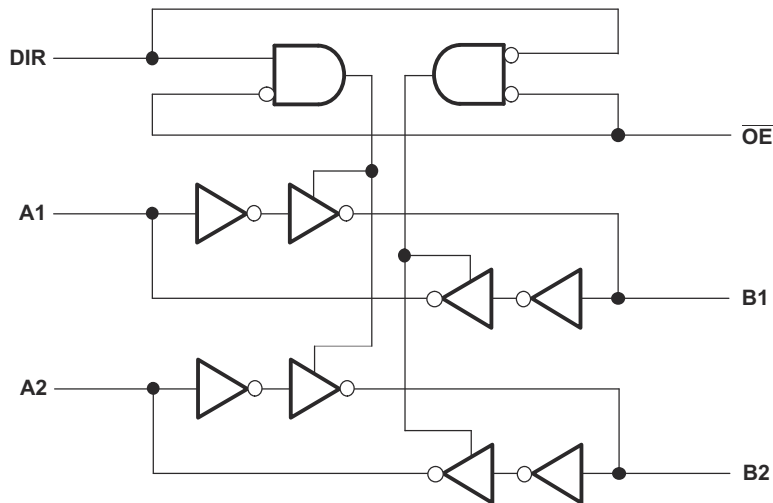


Figure 7-1. Logic Diagram (Positive Logic) for 1/2 of SN74AVC4T245

## 7.3 Feature Description

### 7.3.1 Fully Configurable Dual-Rail Design

The fully configurable dual-rail design allows each port to operate over the full 1.2V to 3.6V power-supply range. Both  $V_{CCA}$  and  $V_{CCB}$  can be supplied at any voltage between 1.2V and 3.6V; thus, making the device an excellent choice for translating between any of the low voltage nodes (1.2V, 1.8V, 2.5V, and 3.3V).

### 7.3.2 Supports High Speed Translation

The SN74AVC4T245 device can support high data rate applications. The translated signal data rate can be up to 380Mbps when the signal is translated from 1.8V to 3.3V.

### 7.3.3 $I_{off}$ Supports Partial-Power-Down Mode Operation

$I_{off}$  will prevent backflow current by disabling I/O output circuits when the device is in partial-power-down mode.

## 7.4 Device Functional Modes

**Table 7-1. Function Table  
(Each 2-Bit Section)**

| CONTROL INPUTS  |     | OUTPUT CIRCUITS |         | OPERATION <sup>(1)</sup> |
|-----------------|-----|-----------------|---------|--------------------------|
| $\overline{OE}$ | DIR | A PORT          | B PORT  |                          |
| L               | L   | Enabled         | Hi-Z    | B data to A bus          |
| L               | H   | Hi-Z            | Enabled | A data to B bus          |
| H               | X   | Hi-Z            | Hi-Z    | Isolation                |

(1) Input circuits of the data I/Os are always active.

## 8 Application and Implementation

### Note

Information in the following applications sections is not part of the TI component specification, and TI does not warrant its accuracy or completeness. TI's customers are responsible for determining suitability of components for their purposes. Customers should validate and test their design implementation to confirm system functionality.

### 8.1 Application Information

The SN74AVC4T245 device can be used in level-translation applications for interfacing devices or systems operating at different interface voltages with one another. The SN74AVC4T245 device is an excellent choice for applications where a push-pull driver is connected to the data I/Os. The maximum data rate can be up to 380Mbps when device translates a signal from 1.8V to 3.3V.

### 8.2 Typical Application

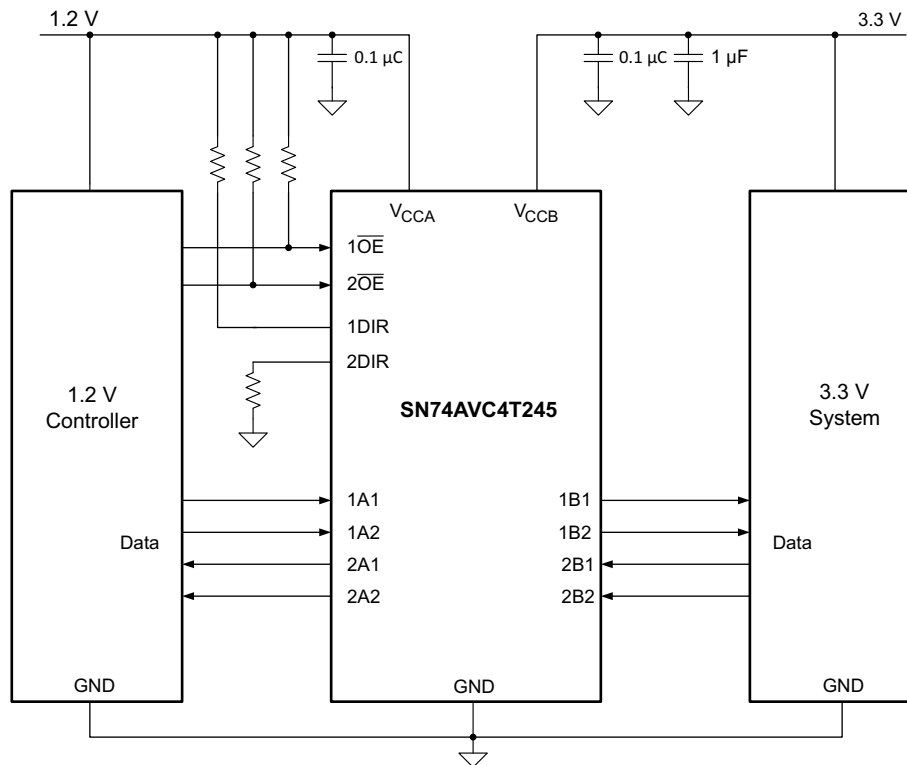


Figure 8-1. Typical Application Diagram

### 8.2.1 Design Requirements

For the design example shown in [Section 8.2](#) use the parameters listed in [Table 8-1](#).

**Table 8-1. Design Parameters**

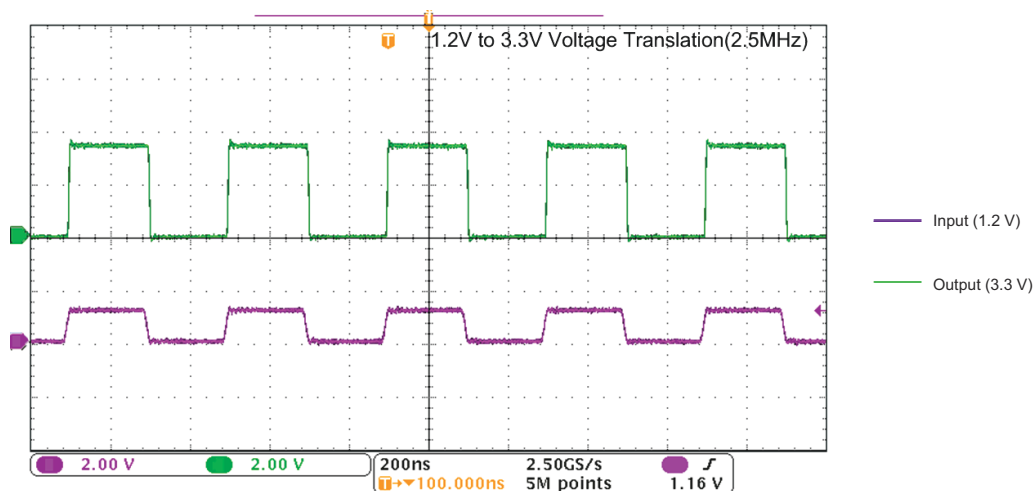
| DESIGN PARAMETER     | EXAMPLE VALUE |
|----------------------|---------------|
| Input voltage range  | 1.2V to 3.6V  |
| Output voltage range | 1.2V to 3.6V  |

### 8.2.2 Detailed Design Procedure

To begin the design process, determine the following:

- Input voltage range
  - Use the supply voltage of the device that is driving the SN74AVC4T245 device to determine the input voltage range. For a valid logic high, the value must exceed the  $V_{IH}$  of the input port. For a valid logic low, the value must be less than the  $V_{IL}$  of the input port.
- Output voltage range
  - Use the supply voltage of the device that the SN74AVC4T245 device is driving to determine the output voltage range.

### 8.2.3 Application Curves



**Figure 8-2. Translation Up (1.2V to 3.3V) at 2.5MHz**

### 8.3 Power Supply Recommendations

The SN74AVC4T245 device uses two separate configurable power-supply rails,  $V_{CCA}$  and  $V_{CCB}$ .  $V_{CCA}$  accepts any supply voltage from 1.2V to 3.6V and  $V_{CCB}$  accepts any supply voltage from 1.2V to 3.6V. The A port and B port are designed to track  $V_{CCA}$  and  $V_{CCB}$  respectively allowing for low-voltage bidirectional translation between any of the 1.2V, 1.5V, 1.8V, 2.5V and 3.3V voltage nodes.

The output-enable ( $\overline{OE}$ ) input circuit is designed so that  $V_{CCA}$  supplies  $\overline{OE}$ , and when the  $\overline{OE}$  input is high, all outputs are placed in the high-impedance state. To put the outputs in the high-impedance state during power up or power down, the  $\overline{OE}$  input pin must be tied to  $V_{CCA}$  through a pullup resistor and must not be enabled until  $V_{CCA}$  and  $V_{CCB}$  are fully ramped and stable. The current-sinking capability of the driver determines the minimum value of the pullup resistor to  $V_{CCA}$ .

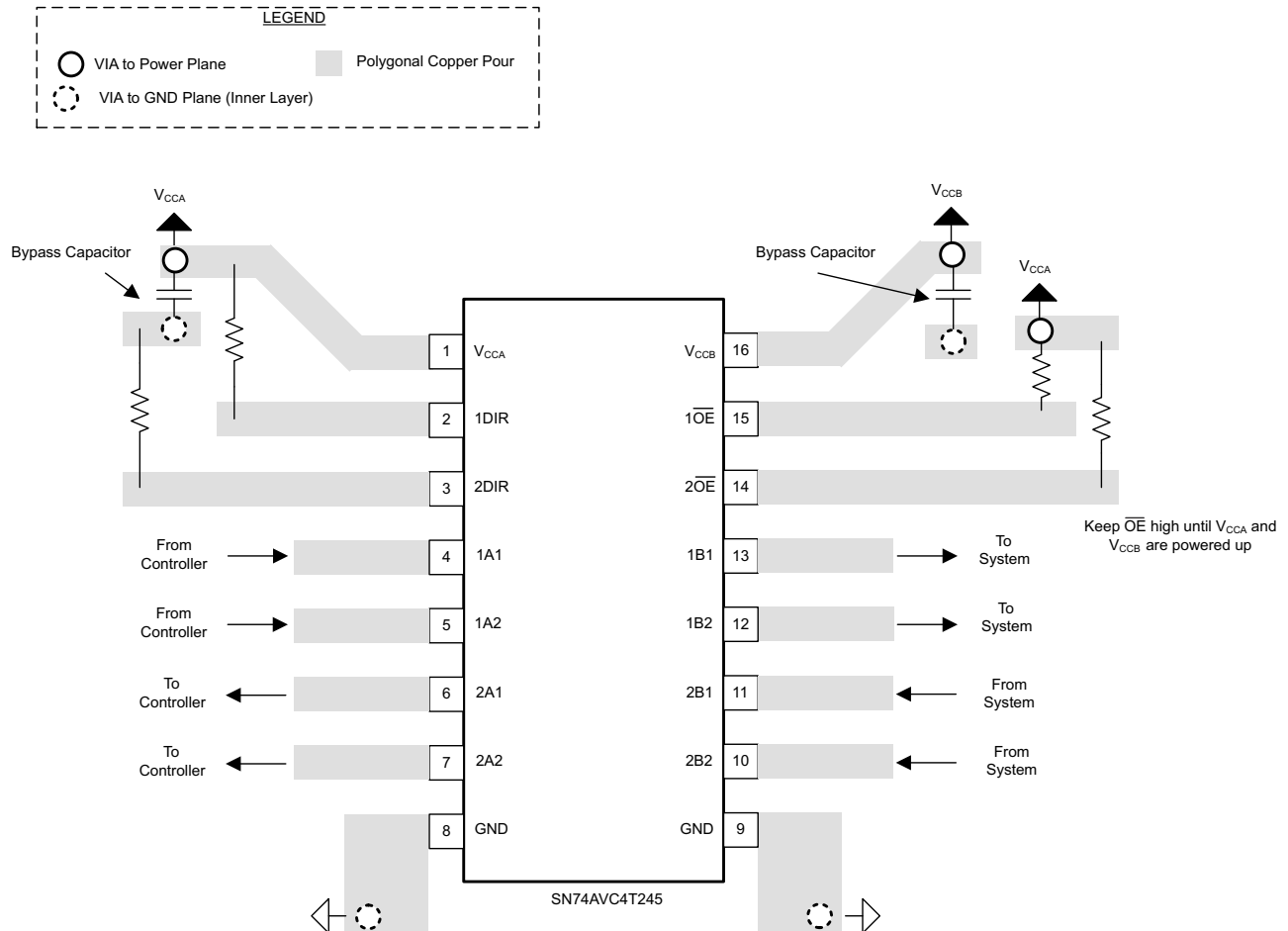
## 8.4 Layout

### 8.4.1 Layout Guidelines

For device reliability, it is recommended to follow common printed-circuit board layout guidelines, such as follows:

- Bypass capacitors should be used on power supplies.
- Short trace lengths should be used to avoid excessive loading.
- Place pads on the signal paths for loading capacitors or pullup resistors to help adjust rise and fall times of signals, depending on the system requirements.

### 8.4.2 Layout Example



## 9 Device and Documentation Support

### 9.1 Receiving Notification of Documentation Updates

To receive notification of documentation updates, navigate to the device product folder on [ti.com](http://ti.com). Click on *Notifications* to register and receive a weekly digest of any product information that has changed. For change details, review the revision history included in any revised document.

### 9.2 Support Resources

[TI E2E™ support forums](#) are an engineer's go-to source for fast, verified answers and design help — straight from the experts. Search existing answers or ask your own question to get the quick design help you need.

Linked content is provided "AS IS" by the respective contributors. They do not constitute TI specifications and do not necessarily reflect TI's views; see TI's [Terms of Use](#).

### 9.3 Trademarks

TI E2E™ is a trademark of Texas Instruments.  
All trademarks are the property of their respective owners.

### 9.4 Electrostatic Discharge Caution



This integrated circuit can be damaged by ESD. Texas Instruments recommends that all integrated circuits be handled with appropriate precautions. Failure to observe proper handling and installation procedures can cause damage.

ESD damage can range from subtle performance degradation to complete device failure. Precision integrated circuits may be more susceptible to damage because very small parametric changes could cause the device not to meet its published specifications.

### 9.5 Glossary

[TI Glossary](#) This glossary lists and explains terms, acronyms, and definitions.

## 10 Revision History

NOTE: Page numbers for previous revisions may differ from page numbers in the current version.

### Changes from Revision G (November 2014) to Revision H (March 2024) Page

- Updated the numbering format for tables, figures, and cross-references throughout the document..... 1
- Added the BQB and DYY package information throughout the data sheet..... 1
- Updated the package information table to include package lead size..... 1

### Changes from Revision F (October 2014) to Revision G (November 2014) Page

- Changed *Pin Functions* table. .... 3
- Changed *Typical Application* schematic. .... 16

### Changes from Revision E (December 2011) to Revision F (October 2014) Page

- Added *Applications, Pin Configuration and Functions* section, *Handling Rating* table, *Thermal Information* table, *Feature Description* section, *Typical Characteristics* section, *Device Functional Modes, Application and Implementation* section, *Power Supply Recommendations* section, *Layout* section, *Device and Documentation Support* section, and *Mechanical, Packaging, and Orderable Information* section ..... 1

### Changes from Revision D (September 2007) to Revision E (December 2011) Page

- Fixed  $t_{PZL}$   $V_{CCB} = 3.3V$  parameter typographical error from 36.6 to 3.6..... 9

## 11 Mechanical, Packaging, and Orderable Information

The following pages include mechanical, packaging, and orderable information. This information is the most current data available for the designated devices. This data is subject to change without notice and revision of this document. For browser-based versions of this data sheet, refer to the left-hand navigation.

**PACKAGING INFORMATION**

| Orderable Device  | Status<br>(1) | Package Type | Package Drawing | Pins | Package Qty | Eco Plan<br>(2) | Lead finish/<br>Ball material<br>(6) | MSL Peak Temp<br>(3) | Op Temp (°C) | Device Marking<br>(4/5) | Samples                 |
|-------------------|---------------|--------------|-----------------|------|-------------|-----------------|--------------------------------------|----------------------|--------------|-------------------------|-------------------------|
| 74AVC4T245DGVRE4  | ACTIVE        | TVSOP        | DGV             | 16   | 2000        | RoHS & Green    | NIPDAU                               | Level-1-260C-UNLIM   | -40 to 85    | WT245                   | <a href="#">Samples</a> |
| 74AVC4T245RGYRG4  | ACTIVE        | VQFN         | RGY             | 16   | 3000        | RoHS & Green    | NIPDAU                               | Level-2-260C-1 YEAR  | -40 to 85    | WT245                   | <a href="#">Samples</a> |
| 74AVC4T245RSVR-NT | ACTIVE        | UQFN         | RSV             | 16   | 3000        | RoHS & Green    | NIPDAU                               | Level-1-260C-UNLIM   | -40 to 85    | ZWU                     | <a href="#">Samples</a> |
| 74AVC4T245RSVRG4  | ACTIVE        | UQFN         | RSV             | 16   | 3000        | RoHS & Green    | NIPDAU                               | Level-1-260C-UNLIM   | -40 to 85    | ZWU                     | <a href="#">Samples</a> |
| SN74AVC4T245D     | ACTIVE        | SOIC         | D               | 16   | 40          | RoHS & Green    | NIPDAU                               | Level-1-260C-UNLIM   | -40 to 85    | AVC4T245                | <a href="#">Samples</a> |
| SN74AVC4T245DGVR  | ACTIVE        | TVSOP        | DGV             | 16   | 2000        | RoHS & Green    | NIPDAU                               | Level-1-260C-UNLIM   | -40 to 85    | WT245                   | <a href="#">Samples</a> |
| SN74AVC4T245DR    | ACTIVE        | SOIC         | D               | 16   | 2500        | RoHS & Green    | NIPDAU                               | Level-1-260C-UNLIM   | -40 to 85    | AVC4T245                | <a href="#">Samples</a> |
| SN74AVC4T245DRE4  | ACTIVE        | SOIC         | D               | 16   | 2500        | RoHS & Green    | NIPDAU                               | Level-1-260C-UNLIM   | -40 to 85    | AVC4T245                | <a href="#">Samples</a> |
| SN74AVC4T245DT    | ACTIVE        | SOIC         | D               | 16   | 250         | RoHS & Green    | NIPDAU                               | Level-1-260C-UNLIM   | -40 to 85    | AVC4T245                | <a href="#">Samples</a> |
| SN74AVC4T245PW    | ACTIVE        | TSSOP        | PW              | 16   | 90          | RoHS & Green    | NIPDAU                               | Level-1-260C-UNLIM   | -40 to 85    | WT245                   | <a href="#">Samples</a> |
| SN74AVC4T245PWE4  | ACTIVE        | TSSOP        | PW              | 16   | 90          | RoHS & Green    | NIPDAU                               | Level-1-260C-UNLIM   | -40 to 85    | WT245                   | <a href="#">Samples</a> |
| SN74AVC4T245PWR   | ACTIVE        | TSSOP        | PW              | 16   | 2000        | RoHS & Green    | NIPDAU                               | Level-1-260C-UNLIM   | -40 to 85    | WT245                   | <a href="#">Samples</a> |
| SN74AVC4T245PWRE4 | ACTIVE        | TSSOP        | PW              | 16   | 2000        | RoHS & Green    | NIPDAU                               | Level-1-260C-UNLIM   | -40 to 85    | WT245                   | <a href="#">Samples</a> |
| SN74AVC4T245PWRG4 | ACTIVE        | TSSOP        | PW              | 16   | 2000        | RoHS & Green    | NIPDAU                               | Level-1-260C-UNLIM   | -40 to 85    | WT245                   | <a href="#">Samples</a> |
| SN74AVC4T245PWT   | ACTIVE        | TSSOP        | PW              | 16   | 250         | RoHS & Green    | NIPDAU                               | Level-1-260C-UNLIM   | -40 to 85    | WT245                   | <a href="#">Samples</a> |
| SN74AVC4T245PWTE4 | ACTIVE        | TSSOP        | PW              | 16   | 250         | RoHS & Green    | NIPDAU                               | Level-1-260C-UNLIM   | -40 to 85    | WT245                   | <a href="#">Samples</a> |
| SN74AVC4T245PWTG4 | ACTIVE        | TSSOP        | PW              | 16   | 250         | RoHS & Green    | NIPDAU                               | Level-1-260C-UNLIM   | -40 to 85    | WT245                   | <a href="#">Samples</a> |
| SN74AVC4T245RGYR  | ACTIVE        | VQFN         | RGY             | 16   | 3000        | RoHS & Green    | NIPDAU                               | Level-2-260C-1 YEAR  | -40 to 85    | WT245                   | <a href="#">Samples</a> |
| SN74AVC4T245RSVR  | ACTIVE        | UQFN         | RSV             | 16   | 3000        | RoHS & Green    | NIPDAU                               | Level-1-260C-UNLIM   | -40 to 85    | ZWU                     | <a href="#">Samples</a> |

<sup>(1)</sup> The marketing status values are defined as follows:

**ACTIVE:** Product device recommended for new designs.

**LIFEBUY:** TI has announced that the device will be discontinued, and a lifetime-buy period is in effect.

**NRND:** Not recommended for new designs. Device is in production to support existing customers, but TI does not recommend using this part in a new design.

**PREVIEW:** Device has been announced but is not in production. Samples may or may not be available.

**OBSOLETE:** TI has discontinued the production of the device.

<sup>(2)</sup> **RoHS:** TI defines "RoHS" to mean semiconductor products that are compliant with the current EU RoHS requirements for all 10 RoHS substances, including the requirement that RoHS substance do not exceed 0.1% by weight in homogeneous materials. Where designed to be soldered at high temperatures, "RoHS" products are suitable for use in specified lead-free processes. TI may reference these types of products as "Pb-Free".

**RoHS Exempt:** TI defines "RoHS Exempt" to mean products that contain lead but are compliant with EU RoHS pursuant to a specific EU RoHS exemption.

**Green:** TI defines "Green" to mean the content of Chlorine (Cl) and Bromine (Br) based flame retardants meet JS709B low halogen requirements of <=1000ppm threshold. Antimony trioxide based flame retardants must also meet the <=1000ppm threshold requirement.

<sup>(3)</sup> MSL, Peak Temp. - The Moisture Sensitivity Level rating according to the JEDEC industry standard classifications, and peak solder temperature.

<sup>(4)</sup> There may be additional marking, which relates to the logo, the lot trace code information, or the environmental category on the device.

<sup>(5)</sup> Multiple Device Markings will be inside parentheses. Only one Device Marking contained in parentheses and separated by a "~" will appear on a device. If a line is indented then it is a continuation of the previous line and the two combined represent the entire Device Marking for that device.

<sup>(6)</sup> Lead finish/Ball material - Orderable Devices may have multiple material finish options. Finish options are separated by a vertical ruled line. Lead finish/Ball material values may wrap to two lines if the finish value exceeds the maximum column width.

**Important Information and Disclaimer:**The information provided on this page represents TI's knowledge and belief as of the date that it is provided. TI bases its knowledge and belief on information provided by third parties, and makes no representation or warranty as to the accuracy of such information. Efforts are underway to better integrate information from third parties. TI has taken and continues to take reasonable steps to provide representative and accurate information but may not have conducted destructive testing or chemical analysis on incoming materials and chemicals. TI and TI suppliers consider certain information to be proprietary, and thus CAS numbers and other limited information may not be available for release.

In no event shall TI's liability arising out of such information exceed the total purchase price of the TI part(s) at issue in this document sold by TI to Customer on an annual basis.

**OTHER QUALIFIED VERSIONS OF SN74AVC4T245 :**

- Automotive : [SN74AVC4T245-Q1](#)

NOTE: Qualified Version Definitions:

- Automotive - Q100 devices qualified for high-reliability automotive applications targeting zero defects

**TAPE AND REEL INFORMATION**

**QUADRANT ASSIGNMENTS FOR PIN 1 ORIENTATION IN TAPE**


\*All dimensions are nominal

| Device            | Package Type | Package Drawing | Pins | SPQ  | Reel Diameter (mm) | Reel Width W1 (mm) | A0 (mm) | B0 (mm) | K0 (mm) | P1 (mm) | W (mm) | Pin1 Quadrant |
|-------------------|--------------|-----------------|------|------|--------------------|--------------------|---------|---------|---------|---------|--------|---------------|
| 74AVC4T245RSVR-NT | UQFN         | RSV             | 16   | 3000 | 180.0              | 8.4                | 2.0     | 2.8     | 0.7     | 4.0     | 8.0    | Q1            |
| 74AVC4T245RSVR-NT | UQFN         | RSV             | 16   | 3000 | 180.0              | 9.5                | 2.1     | 2.9     | 0.75    | 4.0     | 8.0    | Q1            |
| SN74AVC4T245DGVR  | TVSOP        | DGV             | 16   | 2000 | 330.0              | 12.4               | 6.8     | 4.0     | 1.6     | 8.0     | 12.0   | Q1            |
| SN74AVC4T245DR    | SOIC         | D               | 16   | 2500 | 330.0              | 16.4               | 6.5     | 10.3    | 2.1     | 8.0     | 16.0   | Q1            |
| SN74AVC4T245PWR   | TSSOP        | PW              | 16   | 2000 | 330.0              | 12.4               | 6.9     | 5.6     | 1.6     | 8.0     | 12.0   | Q1            |
| SN74AVC4T245PWT   | TSSOP        | PW              | 16   | 250  | 330.0              | 12.4               | 6.9     | 5.6     | 1.6     | 8.0     | 12.0   | Q1            |
| SN74AVC4T245RGYR  | VQFN         | RGY             | 16   | 3000 | 330.0              | 12.4               | 3.8     | 4.3     | 1.5     | 8.0     | 12.0   | Q1            |
| SN74AVC4T245RSVR  | UQFN         | RSV             | 16   | 3000 | 178.0              | 13.5               | 2.1     | 2.9     | 0.75    | 4.0     | 12.0   | Q1            |

**TAPE AND REEL BOX DIMENSIONS**


\*All dimensions are nominal

| Device            | Package Type | Package Drawing | Pins | SPQ  | Length (mm) | Width (mm) | Height (mm) |
|-------------------|--------------|-----------------|------|------|-------------|------------|-------------|
| 74AVC4T245RSVR-NT | UQFN         | RSV             | 16   | 3000 | 200.0       | 183.0      | 25.0        |
| 74AVC4T245RSVR-NT | UQFN         | RSV             | 16   | 3000 | 189.0       | 185.0      | 36.0        |
| SN74AVC4T245DGVR  | TVSOP        | DGV             | 16   | 2000 | 356.0       | 356.0      | 35.0        |
| SN74AVC4T245DR    | SOIC         | D               | 16   | 2500 | 340.5       | 336.1      | 32.0        |
| SN74AVC4T245PWR   | TSSOP        | PW              | 16   | 2000 | 356.0       | 356.0      | 35.0        |
| SN74AVC4T245PWT   | TSSOP        | PW              | 16   | 250  | 356.0       | 356.0      | 35.0        |
| SN74AVC4T245RGYR  | VQFN         | RGY             | 16   | 3000 | 356.0       | 356.0      | 35.0        |
| SN74AVC4T245RSVR  | UQFN         | RSV             | 16   | 3000 | 189.0       | 185.0      | 36.0        |

**TUBE**


\*All dimensions are nominal

| Device           | Package Name | Package Type | Pins | SPQ | L (mm) | W (mm) | T (μm) | B (mm) |
|------------------|--------------|--------------|------|-----|--------|--------|--------|--------|
| SN74AVC4T245D    | D            | SOIC         | 16   | 40  | 507    | 8      | 3940   | 4.32   |
| SN74AVC4T245PW   | PW           | TSSOP        | 16   | 90  | 530    | 10.2   | 3600   | 3.5    |
| SN74AVC4T245PWE4 | PW           | TSSOP        | 16   | 90  | 530    | 10.2   | 3600   | 3.5    |

DGV (R-PDSO-G\*\*)

PLASTIC SMALL-OUTLINE

24 PINS SHOWN



- NOTES: A. All linear dimensions are in millimeters.  
 B. This drawing is subject to change without notice.  
 C. Body dimensions do not include mold flash or protrusion, not to exceed 0,15 per side.  
 D. Falls within JEDEC: 24/48 Pins – MO-153  
 14/16/20/56 Pins – MO-194

## GENERIC PACKAGE VIEW

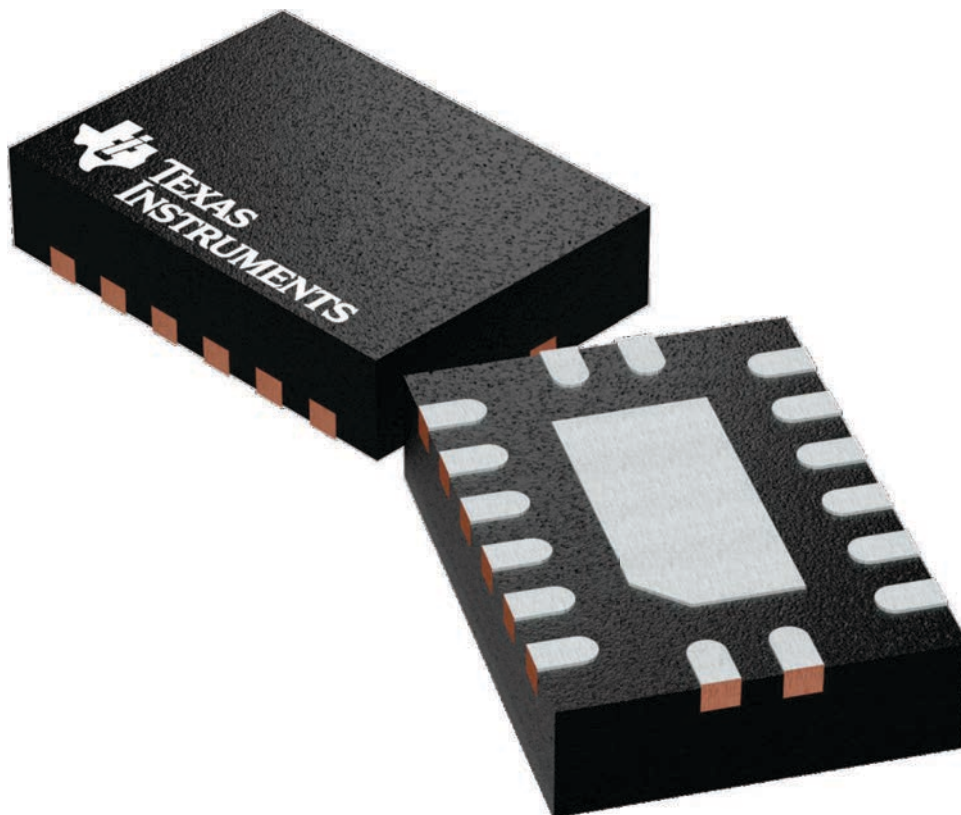
**BQB 16**

**WQFN - 0.8 mm max height**

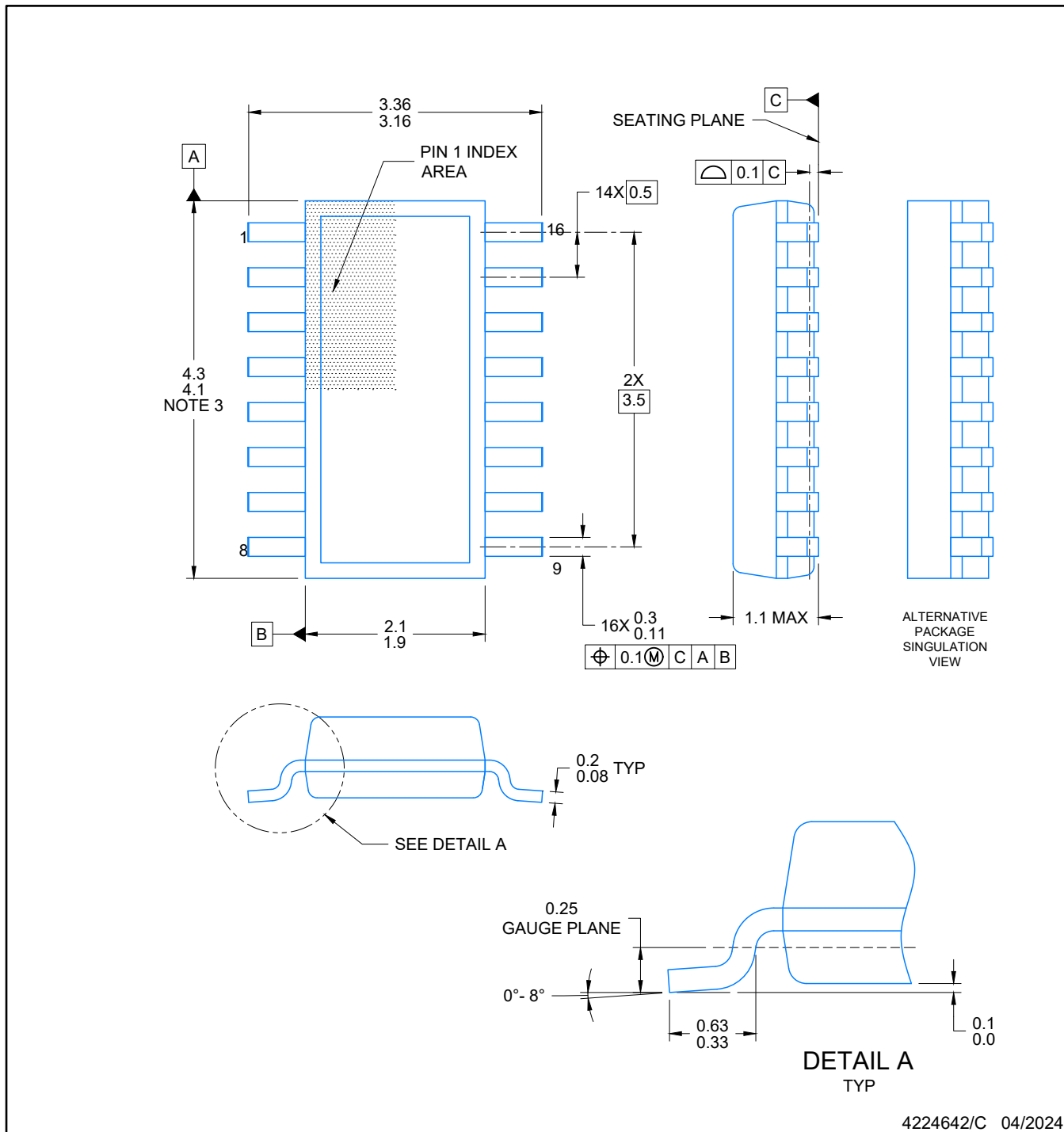
2.5 x 3.5, 0.5 mm pitch

PLASTIC QUAD FLATPACK - NO LEAD

This image is a representation of the package family, actual package may vary.  
Refer to the product data sheet for package details.



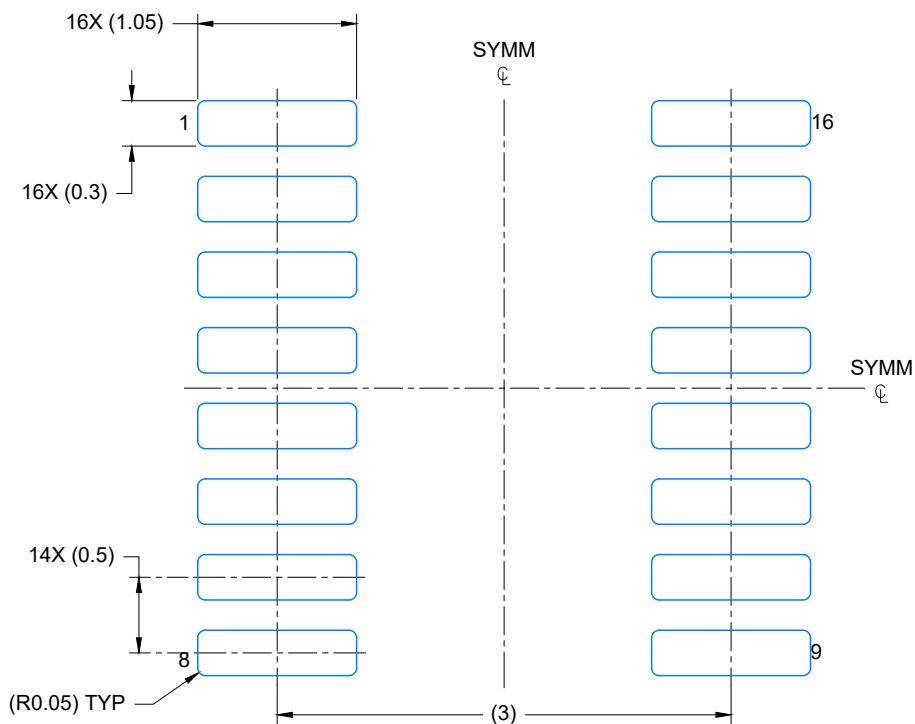
4226161/A



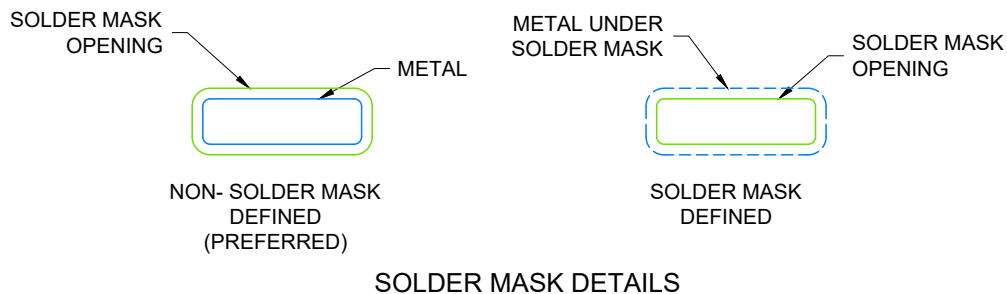
4224642/C 04/2024

NOTES:

1. All linear dimensions are in millimeters. Any dimensions in parenthesis are for reference only. Dimensioning and tolerancing per ASME Y14.5M.
2. This drawing is subject to change without notice.
3. This dimension does not include mold flash, protrusions, or gate burrs. Mold flash, protrusions, or gate burrs shall not exceed 0.15 per side.
4. This dimension does not include interlead flash. Interlead flash shall not exceed 0.50 per side.
5. Reference JEDEC Registration MO-345, Variation AA



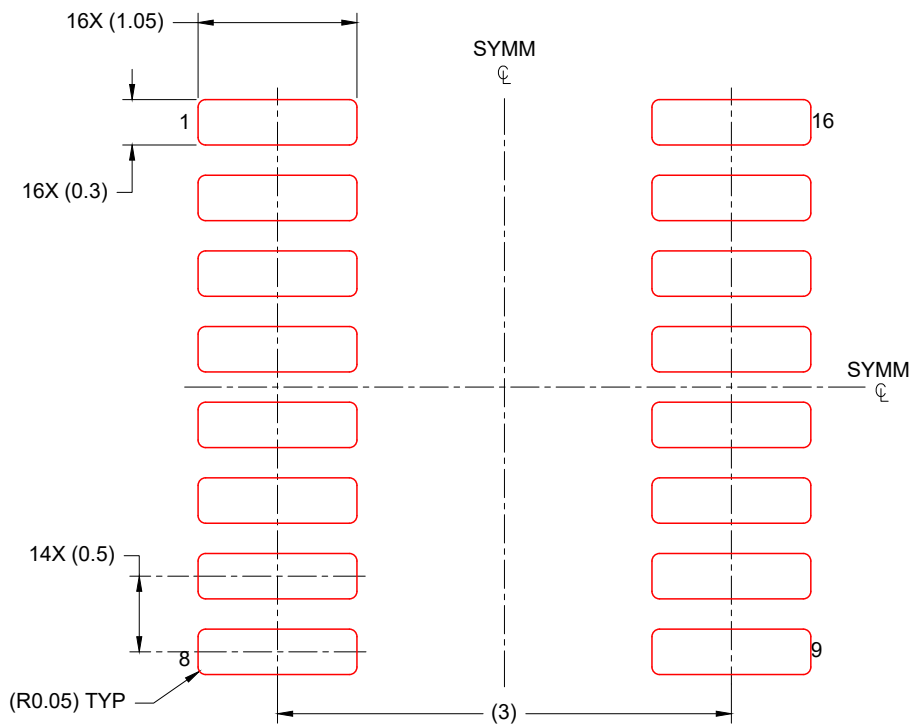
LAND PATTERN EXAMPLE  
EXPOSED METAL SHOWN  
SCALE: 20X



4224642/C 04/2024

NOTES: (continued)

- 6. Publication IPC-7351 may have alternate designs.
- 7. Solder mask tolerances between and around signal pads can vary based on board fabrication site.



SOLDER PASTE EXAMPLE  
BASED ON 0.125 mm THICK STENCIL  
SCALE: 20X

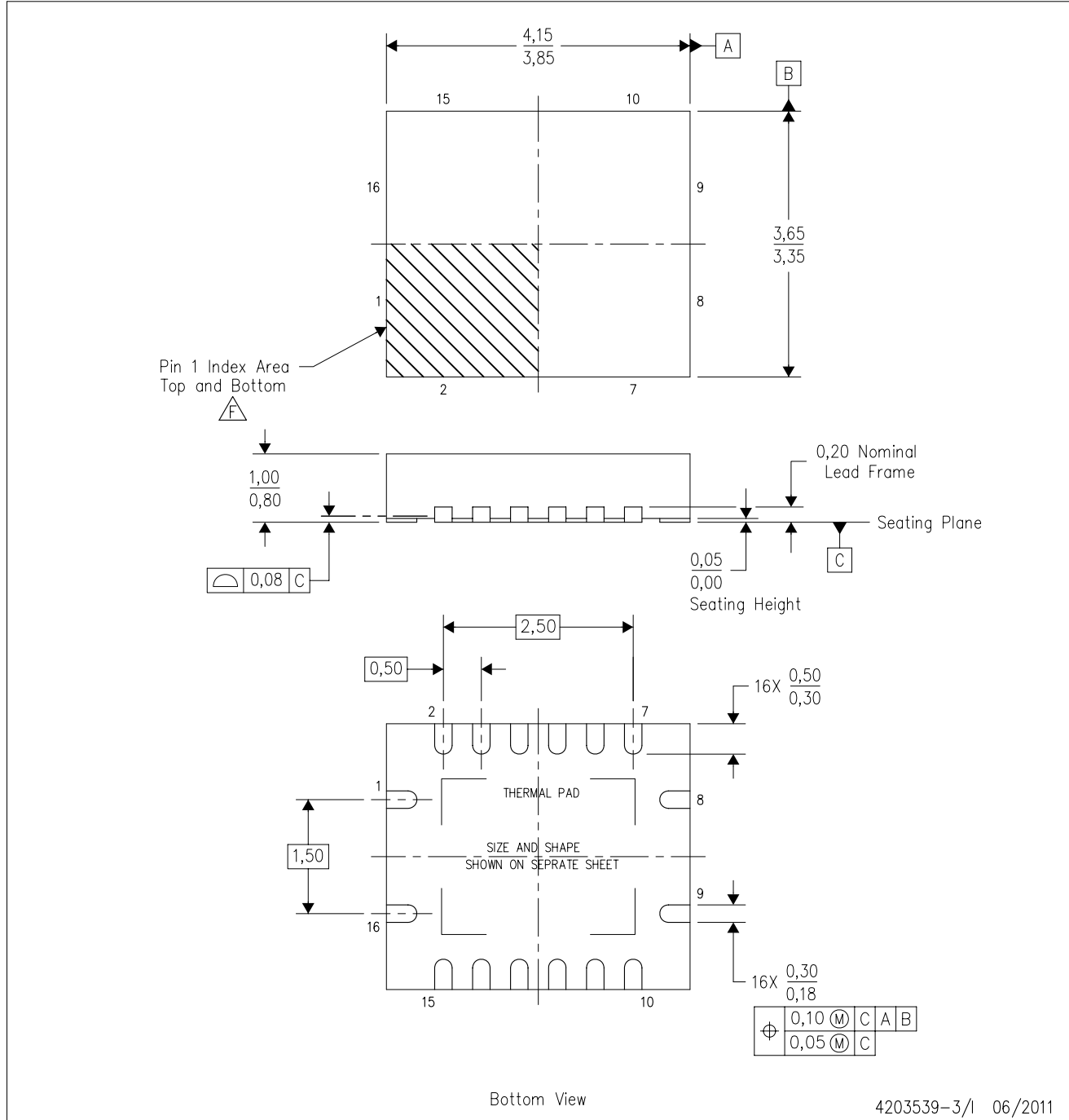
4224642/C 04/2024

NOTES: (continued)

- 8. Laser cutting apertures with trapezoidal walls and rounded corners may offer better paste release. IPC-7525 may have alternate design recommendations.
- 9. Board assembly site may have different recommendations for stencil design.

RGY (R-PVQFN-N16)

PLASTIC QUAD FLATPACK NO-LEAD



- NOTES:
- A. All linear dimensions are in millimeters. Dimensioning and tolerancing per ASME Y14.5M-1994.
  - B. This drawing is subject to change without notice.
  - C. QFN (Quad Flatpack No-Lead) package configuration.
  - D. The package thermal pad must be soldered to the board for thermal and mechanical performance.
  - E. See the additional figure in the Product Data Sheet for details regarding the exposed thermal pad features and dimensions.
  - F. Pin 1 identifiers are located on both top and bottom of the package and within the zone indicated. The Pin 1 identifiers are either a molded, marked, or metal feature.
  - G. Package complies to JEDEC MO-241 variation BA.

RGY (R-PVQFN-N16)

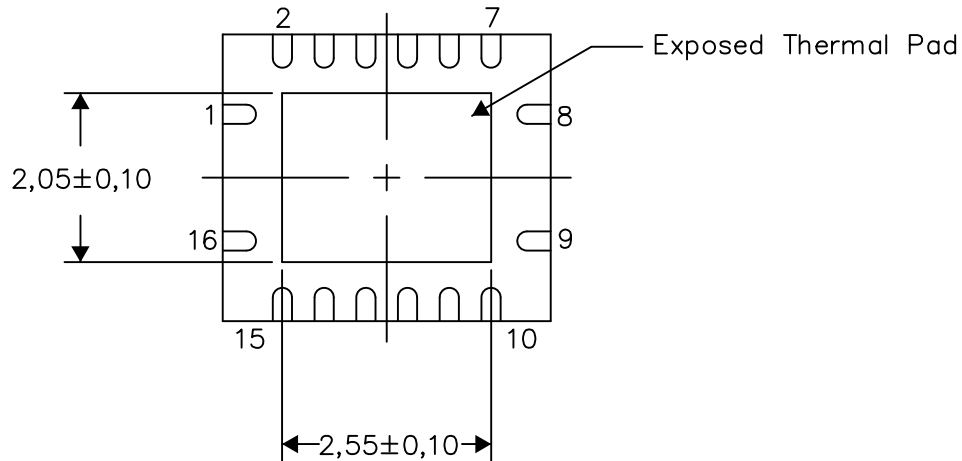
PLASTIC QUAD FLATPACK NO-LEAD

**THERMAL INFORMATION**

This package incorporates an exposed thermal pad that is designed to be attached directly to an external heatsink. The thermal pad must be soldered directly to the printed circuit board (PCB). After soldering, the PCB can be used as a heatsink. In addition, through the use of thermal vias, the thermal pad can be attached directly to the appropriate copper plane shown in the electrical schematic for the device, or alternatively, can be attached to a special heatsink structure designed into the PCB. This design optimizes the heat transfer from the integrated circuit (IC).

For information on the Quad Flatpack No-Lead (QFN) package and its advantages, refer to Application Report, QFN/SON PCB Attachment, Texas Instruments Literature No. SLUA271. This document is available at [www.ti.com](http://www.ti.com).

The exposed thermal pad dimensions for this package are shown in the following illustration.



Bottom View

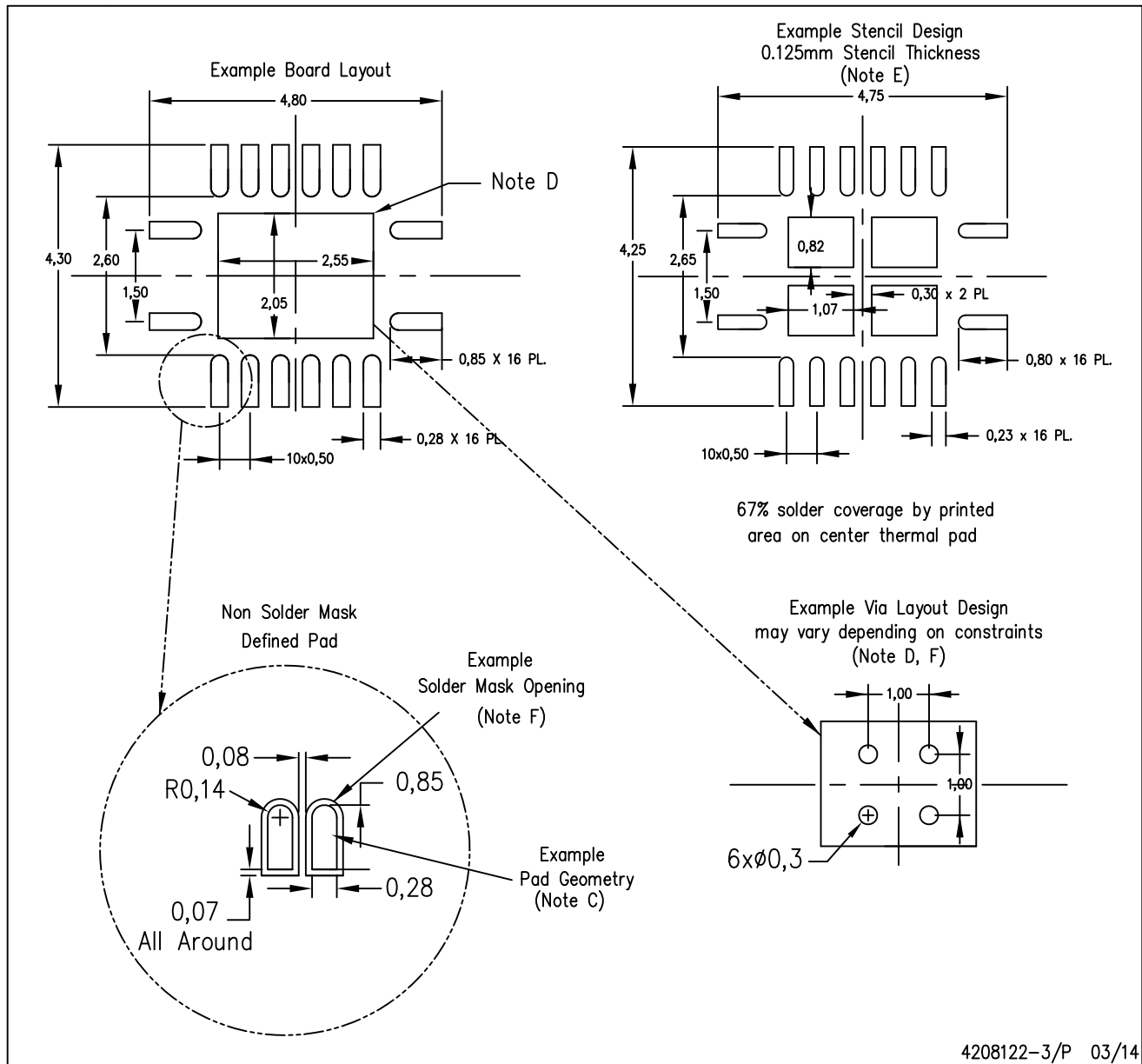
Exposed Thermal Pad Dimensions

4206353-3/P 03/14

NOTE: All linear dimensions are in millimeters

RGY (R-PVQFN-N16)

PLASTIC QUAD FLATPACK NO-LEAD



4208122-3/P 03/14

- NOTES:
- A. All linear dimensions are in millimeters.
  - B. This drawing is subject to change without notice.
  - C. Publication IPC-7351 is recommended for alternate designs.
  - D. This package is designed to be soldered to a thermal pad on the board. Refer to Application Note, Quad Flat-Pack QFN/SON PCB Attachment, Texas Instruments Literature No. SLUA271, and also the Product Data Sheets for specific thermal information, via requirements, and recommended board layout. These documents are available at [www.ti.com](http://www.ti.com) <<http://www.ti.com>>.
  - E. Laser cutting apertures with trapezoidal walls and also rounding corners will offer better paste release. Customers should contact their board assembly site for stencil design recommendations. Refer to IPC 7525 for stencil design considerations.
  - F. Customers should contact their board fabrication site for minimum solder mask web tolerances between signal pads.

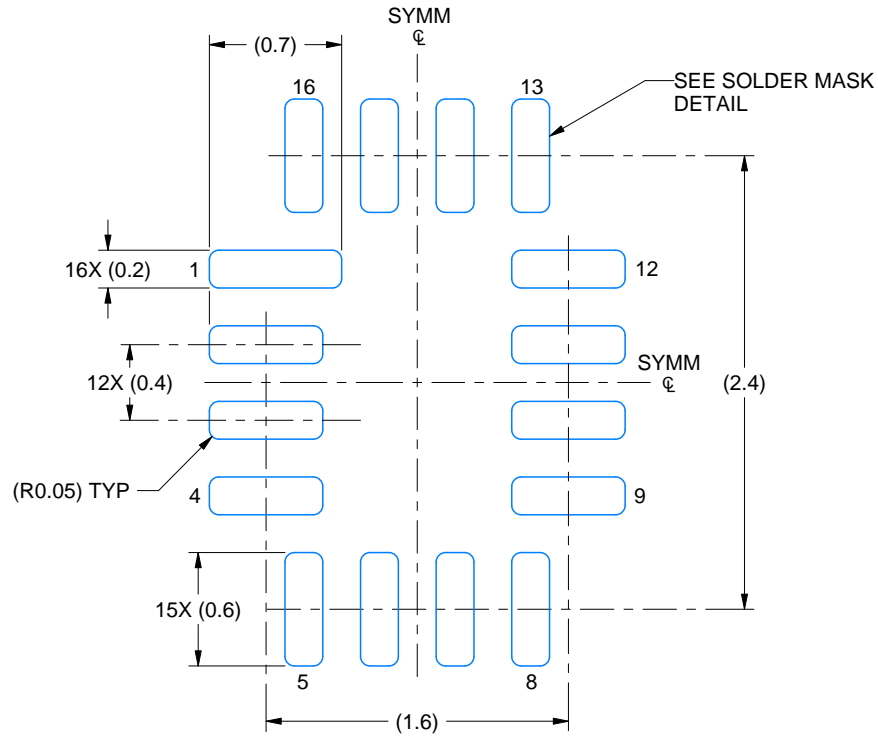


# EXAMPLE BOARD LAYOUT

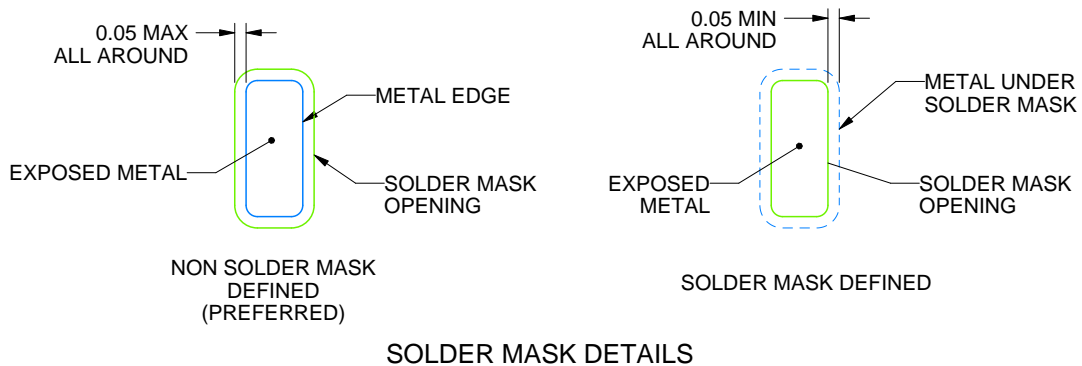
RSV0016A

UQFN - 0.55 mm max height

ULTRA THIN QUAD FLATPACK - NO LEAD



LAND PATTERN EXAMPLE  
EXPOSED METAL SHOWN  
SCALE: 25X



4220314/C 02/2020

NOTES: (continued)

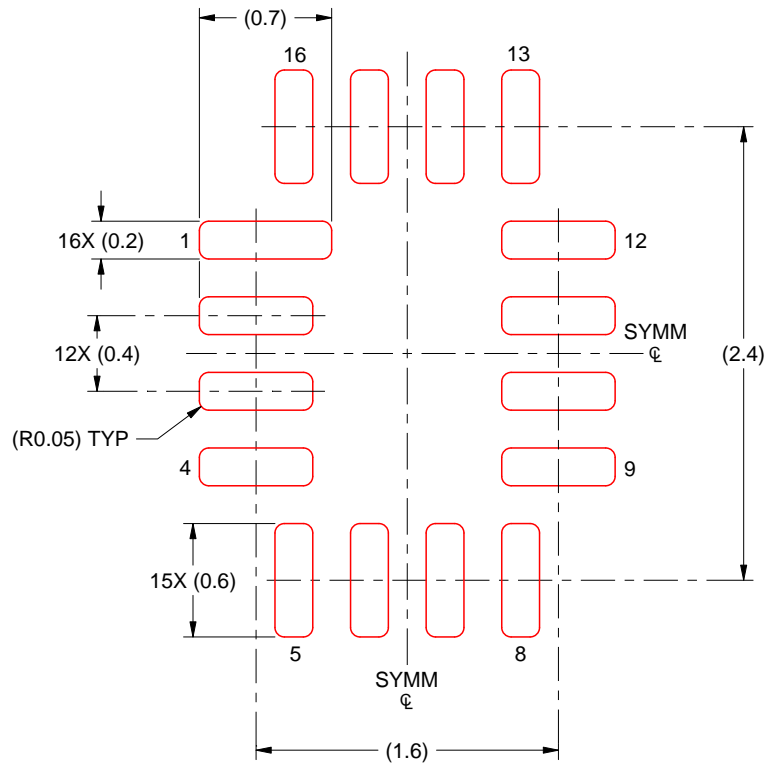
3. For more information, see Texas Instruments literature number SLUA271 ([www.ti.com/lit/slua271](http://www.ti.com/lit/slua271)).

# EXAMPLE STENCIL DESIGN

RSV0016A

UQFN - 0.55 mm max height

ULTRA THIN QUAD FLATPACK - NO LEAD



SOLDER PASTE EXAMPLE  
BASED ON 0.125 MM THICK STENCIL  
SCALE: 25X

4220314/C 02/2020

NOTES: (continued)



4. Laser cutting apertures with trapezoidal walls and rounded corners may offer better paste release. IPC-7525 may have alternate design recommendations.

D (R-PDSO-G16)

PLASTIC SMALL OUTLINE



4040047-6/M 06/11

- NOTES:
- A. All linear dimensions are in inches (millimeters).
  - B. This drawing is subject to change without notice.
  -  Body length does not include mold flash, protrusions, or gate burrs. Mold flash, protrusions, or gate burrs shall not exceed 0.006 (0,15) each side.
  -  Body width does not include interlead flash. Interlead flash shall not exceed 0.017 (0,43) each side.
  - E. Reference JEDEC MS-012 variation AC.

D (R-PDSO-G16)

PLASTIC SMALL OUTLINE



- NOTES:
- All linear dimensions are in millimeters.
  - This drawing is subject to change without notice.
  - Publication IPC-7351 is recommended for alternate designs.
  - Laser cutting apertures with trapezoidal walls and also rounding corners will offer better paste release. Customers should contact their board assembly site for stencil design recommendations. Refer to IPC-7525 for other stencil recommendations.
  - Customers should contact their board fabrication site for solder mask tolerances between and around signal pads.



NOTES:

1. All linear dimensions are in millimeters. Any dimensions in parenthesis are for reference only. Dimensioning and tolerancing per ASME Y14.5M.
2. This drawing is subject to change without notice.
3. This dimension does not include mold flash, protrusions, or gate burrs. Mold flash, protrusions, or gate burrs shall not exceed 0.15 mm per side.
4. This dimension does not include interlead flash. Interlead flash shall not exceed 0.25 mm per side.
5. Reference JEDEC registration MO-153.

# EXAMPLE BOARD LAYOUT

PW0016A

TSSOP - 1.2 mm max height

SMALL OUTLINE PACKAGE



LAND PATTERN EXAMPLE  
EXPOSED METAL SHOWN  
SCALE: 10X



SOLDER MASK DETAILS

4220204/A 02/2017

NOTES: (continued)

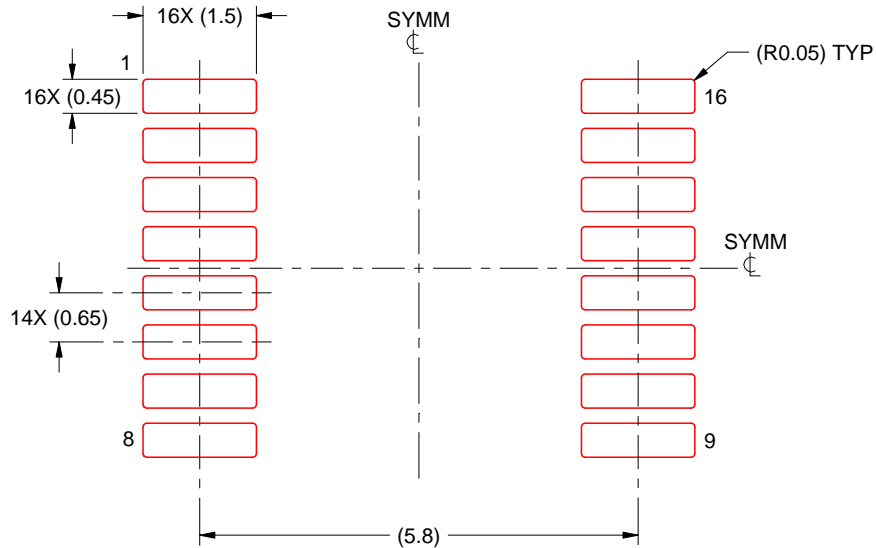
- 6. Publication IPC-7351 may have alternate designs.
- 7. Solder mask tolerances between and around signal pads can vary based on board fabrication site.

# EXAMPLE STENCIL DESIGN

PW0016A

TSSOP - 1.2 mm max height

SMALL OUTLINE PACKAGE



SOLDER PASTE EXAMPLE  
BASED ON 0.125 mm THICK STENCIL  
SCALE: 10X

4220204/A 02/2017

NOTES: (continued)

8. Laser cutting apertures with trapezoidal walls and rounded corners may offer better paste release. IPC-7525 may have alternate design recommendations.
9. Board assembly site may have different recommendations for stencil design.

## IMPORTANT NOTICE AND DISCLAIMER

TI PROVIDES TECHNICAL AND RELIABILITY DATA (INCLUDING DATA SHEETS), DESIGN RESOURCES (INCLUDING REFERENCE DESIGNS), APPLICATION OR OTHER DESIGN ADVICE, WEB TOOLS, SAFETY INFORMATION, AND OTHER RESOURCES "AS IS" AND WITH ALL FAULTS, AND DISCLAIMS ALL WARRANTIES, EXPRESS AND IMPLIED, INCLUDING WITHOUT LIMITATION ANY IMPLIED WARRANTIES OF MERCHANTABILITY, FITNESS FOR A PARTICULAR PURPOSE OR NON-INFRINGEMENT OF THIRD PARTY INTELLECTUAL PROPERTY RIGHTS.

These resources are intended for skilled developers designing with TI products. You are solely responsible for (1) selecting the appropriate TI products for your application, (2) designing, validating and testing your application, and (3) ensuring your application meets applicable standards, and any other safety, security, regulatory or other requirements.

These resources are subject to change without notice. TI grants you permission to use these resources only for development of an application that uses the TI products described in the resource. Other reproduction and display of these resources is prohibited. No license is granted to any other TI intellectual property right or to any third party intellectual property right. TI disclaims responsibility for, and you will fully indemnify TI and its representatives against, any claims, damages, costs, losses, and liabilities arising out of your use of these resources.

TI's products are provided subject to [TI's Terms of Sale](#) or other applicable terms available either on [ti.com](https://www.ti.com) or provided in conjunction with such TI products. TI's provision of these resources does not expand or otherwise alter TI's applicable warranties or warranty disclaimers for TI products.

TI objects to and rejects any additional or different terms you may have proposed.

Mailing Address: Texas Instruments, Post Office Box 655303, Dallas, Texas 75265  
Copyright © 2024, Texas Instruments Incorporated

## Looking for pricing, stock, or lifecycle information?

Click below to explore more details on WIN SOURCE:

 [View SN74AVC4T245RGYR on WIN SOURCE](#)

 [Texas Instruments](#) Information

## Optimize Your Supply Chain with WIN SOURCE Solutions

-  Global Sourcing Solution
-  Obsolete Management
-  Cost Control Management
-  Shortage Management
-  Alternative Solution
-  Excess Inventory Management