



**THE DATASHEET OF  
SN74AUP2G14DCKR**



## LOW-POWER DUAL SCHMITT-TRIGGER INVERTER

Check for Samples: [SN74AUP2G14](#)

### FEATURES

- Available in the Texas Instruments NanoStar™ Package
- Low Static-Power Consumption ( $I_{CC} = 0.9 \mu\text{A}$  Maximum)
- Low Dynamic-Power Consumption ( $C_{pd} = 4.3 \text{ pF}$  Typical at 3.3 V)
- Low Input Capacitance ( $C_i = 1.5 \text{ pF}$  Typical)
- Low Noise – Overshoot and Undershoot <math><10\%</math> of  $V_{CC}$
- $I_{off}$  Supports Partial-Power-Down Mode Operation
- Wide Operating  $V_{CC}$  Range of 0.8 V to 3.6 V
- Optimized for 3.3-V Operation
- 3.6-V I/O Tolerant to Support Mixed-Mode Signal Operation
- $t_{pd} = 4.3 \text{ ns}$  Maximum at 3.3 V
- Suitable for Point-to-Point Applications
- Latch-Up Performance Exceeds 100 mA Per JESD 78, Class II
- ESD Performance Tested Per JESD 22
  - 2000-V Human-Body Model (A114-B, Class II)
  - 1000-V Charged-Device Model (C101)

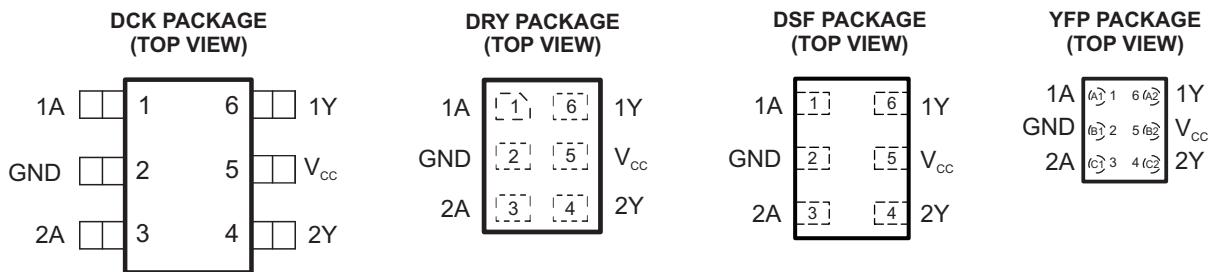

See mechanical drawings for dimensions.

### DESCRIPTION/ORDERING INFORMATION

The AUP family is TI's premier solution to the industry's low-power needs in battery-powered portable applications. This family ensures a very low static- and dynamic-power consumption across the entire  $V_{CC}$  range of 0.8 V to 3.6 V, resulting in increased battery life (see [Figure 1](#)). This product also maintains excellent signal integrity (see the very low undershoot and overshoot characteristics shown in [Figure 2](#)).

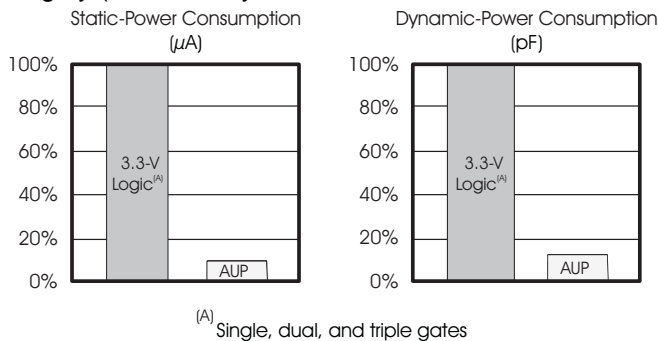
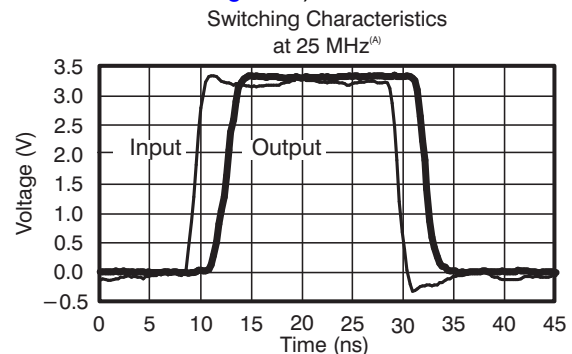
**Figure 1. AUP – The Lowest-Power Family**

<sup>(A)</sup> SN74AUP2Gxx data at  $C_L = 15 \text{ pF}$ .

**Figure 2. Excellent Signal Integrity**

Please be aware that an important notice concerning availability, standard warranty, and use in critical applications of Texas Instruments semiconductor products and disclaimers thereto appears at the end of this data sheet.

NanoStar is a trademark of Texas Instruments.

The SN74AUP2G14 contains two inverters and performs the Boolean function  $Y = \bar{A}$ . The device functions as two independent inverters, but because of Schmitt action, it may have different input threshold levels for positive-going ( $V_{T+}$ ) and negative-going ( $V_{T-}$ ) signals.

NanoStar™ package technology is a major breakthrough in IC packaging concepts, using the die as the package.

This device is fully specified for partial-power-down applications using  $I_{off}$ . The  $I_{off}$  circuitry disables the outputs, preventing damaging current backflow through the device when it is powered down.

**ORDERING INFORMATION (1) (2) (3)**

| T <sub>A</sub> | PACKAGE  |              | ORDERABLE PART NUMBER                             | TOP-SIDE MARKING <sup>(4)</sup> |
|----------------|--|--------------|---|---------------------------------|
| -40°C to 85°C  | NanoStar™ – WCSP (DSBGA)<br>0.23-mm Large Bump – YFP (Pb-free) | Reel of 3000 | SN74AUP2G14YFPR                                   | — H F —                         |
|                | QFN – DSF  | Reel of 5000 | SN74AUP2G14DSFR<br>SN74AUP2G14DSF2 <sup>(3)</sup> | H6                              |
|                | uQFN – DRY   | Reel of 5000 | SN74AUP2G14DRYR                                   | H6                              |
|                | SOT (SC-70) – DCK  | Reel of 3000 | SN74AUP2G14DCKR                                   | H6_                             |

- (1) Package drawings, thermal data, and symbolization are available at [www.ti.com/packaging](http://www.ti.com/packaging).
- (2) For the most current package and ordering information, see the Package Option Addendum at the end of this document, or see the TI website at [www.ti.com](http://www.ti.com).
- (3) Pin 1 orientation at quadrant 3 in Tape.
- (4) DCK: The actual top-side marking has one additional character that designates the wafer fab/assembly site.  
YFP: The actual top-side marking has three preceding characters to denote year, month, and sequence code, and one following character to designate the wafer fab/assembly site. Pin 1 identifier indicates solder-bump composition (1 = SnPb, • = Pb-free).

**FUNCTION TABLE  
(Each Inverter)**

| INPUT<br>A | OUTPUT<br>Y |
|------------|-------------|
| H          | L           |
| L          | H           |

**LOGIC DIAGRAM (POSITIVE LOGIC)**

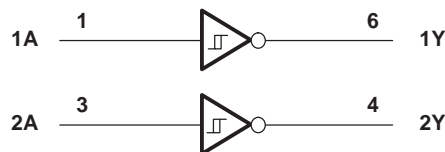

**ABSOLUTE MAXIMUM RATINGS<sup>(1)</sup>**

over operating free-air temperature range (unless otherwise noted)

|               |   |             | <b>MIN</b> | <b>MAX</b>     | <b>UNIT</b> |
|---------------|---|-------------|------------|----------------|-------------|
| $V_{CC}$      | Supply voltage range  |             | –0.5       | 4.6            | V           |
| $V_I$         | Input voltage range <sup>(2)</sup>  |             | –0.5       | 4.6            | V           |
| $V_O$         | Voltage range applied to any output in the high-impedance or power-off state <sup>(2)</sup> |             | –0.5       | 4.6            | V           |
| $V_O$         | Output voltage range in the high or low state <sup>(2)</sup>                                |             | –0.5       | $V_{CC} + 0.5$ | V           |
| $I_{IK}$      | Input clamp current   | $V_I < 0$   |            | –50            | mA          |
| $I_{OK}$      | Output clamp current  | $V_O < 0$   |            | –50            | mA          |
| $I_O$         | Continuous output current   |             |            | ±20            | mA          |
|               | Continuous current through $V_{CC}$ or GND  |             |            | ±50            | mA          |
| $\theta_{JA}$ | Package thermal impedance <sup>(3)</sup>  | DCK package |            | 252            | °C/W        |
|               |   | DSF package |            | 300            |             |
|               |   | DRY package |            | 234            |             |
|               |   | YFP package |            | 132            |             |
| $T_{stg}$     | Storage temperature range   |             | –65        | 150            | °C          |

- (1) Stresses beyond those listed under "absolute maximum ratings" may cause permanent damage to the device. These are stress ratings only, and functional operation of the device at these or any other conditions beyond those indicated under "recommended operating conditions" is not implied. Exposure to absolute-maximum-rated conditions for extended periods may affect device reliability.
- (2) The input negative-voltage and output voltage ratings may be exceeded if the input and output current ratings are observed.
- (3) The package thermal impedance is calculated in accordance with JESD 51-7.

**RECOMMENDED OPERATING CONDITIONS<sup>(1)</sup>**

|          |                                | MIN                      | MAX      | UNIT               |
|----------|--------------------------------|--------------------------|----------|--------------------|
| $V_{CC}$ | Supply voltage                 | 0.8                      | 3.6      | V                  |
| $V_I$    | Input voltage                  | 0                        | 3.6      | V                  |
| $V_O$    | Output voltage                 | 0                        | $V_{CC}$ | V                  |
| $I_{OH}$ | High-level output current      | $V_{CC} = 0.8\text{ V}$  | -20      | $\mu\text{A}$      |
|          |                                | $V_{CC} = 1.1\text{ V}$  | -1.1     | mA                 |
|          |                                | $V_{CC} = 1.4\text{ V}$  | -1.7     |                    |
|          |                                | $V_{CC} = 1.65\text{ V}$ | -1.9     |                    |
|          |                                | $V_{CC} = 2.3\text{ V}$  | -3.1     |                    |
|          |                                | $V_{CC} = 3\text{ V}$    | -4       |                    |
| $I_{OL}$ | Low-level output current       | $V_{CC} = 0.8\text{ V}$  | 20       | $\mu\text{A}$      |
|          |                                | $V_{CC} = 1.1\text{ V}$  | 1.1      | mA                 |
|          |                                | $V_{CC} = 1.4\text{ V}$  | 1.7      |                    |
|          |                                | $V_{CC} = 1.65\text{ V}$ | 1.9      |                    |
|          |                                | $V_{CC} = 2.3\text{ V}$  | 3.1      |                    |
|          |                                | $V_{CC} = 3\text{ V}$    | 4        |                    |
| $T_A$    | Operating free-air temperature | -40                      | 85       | $^{\circ}\text{C}$ |

(1) All unused inputs of the device must be held at  $V_{CC}$  or GND to ensure proper device operation. Refer to the TI application report, Implications of Slow or Floating CMOS Inputs, literature number SCBA004.

## ELECTRICAL CHARACTERISTICS

over recommended operating free-air temperature range (unless otherwise noted)

| PARAMETER   | TEST CONDITIONS           | V <sub>CC</sub>  | T <sub>A</sub> = 25°C  |     |      | T <sub>A</sub> = –40°C to 85°C |      | UNIT |
|---|---------------------------|--|------------------------|-----|------|--------------------------------|------|------|
|   |                           |  | MIN                    | TYP | MAX  | MIN                            | MAX  |      |
| V <sub>T+</sub><br>Positive-going<br>input threshold<br>voltage       |                           | 0.8 V  | 0.3                    |     | 0.6  | 0.3                            | 0.6  | V    |
|   |                           | 1.1 V  | 0.53                   |     | 0.9  | 0.53                           | 0.9  |      |
|   |                           | 1.4 V  | 0.74                   |     | 1.11 | 0.74                           | 1.11 |      |
|   |                           | 1.65 V   | 0.91                   |     | 1.29 | 0.91                           | 1.29 |      |
|   |                           | 2.3 V  | 1.37                   |     | 1.77 | 1.37                           | 1.77 |      |
|   |                           | 3 V  | 1.88                   |     | 2.29 | 1.88                           | 2.29 |      |
| V <sub>T–</sub><br>Negative-going<br>input threshold<br>voltage       |                           | 0.8 V  | 0.1                    |     | 0.6  | 0.1                            | 0.6  | V    |
|   |                           | 1.1 V  | 0.26                   |     | 0.65 | 0.26                           | 0.65 |      |
|   |                           | 1.4 V  | 0.39                   |     | 0.75 | 0.39                           | 0.75 |      |
|   |                           | 1.65 V   | 0.47                   |     | 0.84 | 0.47                           | 0.84 |      |
|   |                           | 2.3 V  | 0.69                   |     | 1.04 | 0.69                           | 1.04 |      |
|   |                           | 3 V  | 0.88                   |     | 1.24 | 0.88                           | 1.24 |      |
| ΔV <sub>T</sub><br>Hysteresis<br>(V <sub>T+</sub> – V <sub>T–</sub> ) |                           | 0.8 V  | 0.07                   |     | 0.5  | 0.07                           | 0.5  | V    |
|   |                           | 1.1 V  | 0.08                   |     | 0.46 | 0.08                           | 0.46 |      |
|   |                           | 1.4 V  | 0.18                   |     | 0.56 | 0.18                           | 0.56 |      |
|   |                           | 1.65 V   | 0.27                   |     | 0.66 | 0.27                           | 0.66 |      |
|   |                           | 2.3 V  | 0.53                   |     | 0.92 | 0.53                           | 0.92 |      |
|   |                           | 3 V  | 0.79                   |     | 1.31 | 0.79                           | 1.31 |      |
| V <sub>OH</sub>   | I <sub>OH</sub> = –20 μA  | 0.8 V to 3.6 V   | V <sub>CC</sub> – 0.1  |     |      | V <sub>CC</sub> – 0.1          |      | V    |
|   | I <sub>OH</sub> = –1.1 mA | 1.1 V  | 0.75 × V <sub>CC</sub> |     |      | 0.7 × V <sub>CC</sub>          |      |      |
|   | I <sub>OH</sub> = –1.7 mA | 1.4 V  | 1.11                   |     |      | 1.03                           |      |      |
|   | I <sub>OH</sub> = –1.9 mA | 1.65 V   | 1.32                   |     |      | 1.3                            |      |      |
|   | I <sub>OH</sub> = –2.3 mA | 2.3 V  | 2.05                   |     |      | 1.97                           |      |      |
|   | I <sub>OH</sub> = –3.1 mA |  | 1.9                    |     |      | 1.85                           |      |      |
|   | I <sub>OH</sub> = –2.7 mA | 3 V  | 2.72                   |     |      | 2.67                           |      |      |
|   | I <sub>OH</sub> = –4 mA   |  | 2.6                    |     |      | 2.55                           |      |      |
| V <sub>OL</sub>   | I <sub>OL</sub> = 20 μA   | 0.8 V to 3.6 V   | 0.1                    |     |      | 0.1                            |      | V    |
|   | I <sub>OL</sub> = 1.1 mA  | 1.1 V  | 0.3 × V <sub>CC</sub>  |     |      | 0.3 × V <sub>CC</sub>          |      |      |
|   | I <sub>OL</sub> = 1.7 mA  | 1.4 V  | 0.31                   |     |      | 0.37                           |      |      |
|   | I <sub>OL</sub> = 1.9 mA  | 1.65 V   | 0.31                   |     |      | 0.35                           |      |      |
|   | I <sub>OL</sub> = 2.3 mA  | 2.3 V  | 0.31                   |     |      | 0.33                           |      |      |
|   | I <sub>OL</sub> = 3.1 mA  |  | 0.44                   |     |      | 0.45                           |      |      |
|   | I <sub>OL</sub> = 2.7 mA  | 3 V  | 0.31                   |     |      | 0.33                           |      |      |
|   | I <sub>OL</sub> = 4 mA    |  | 0.44                   |     |      | 0.45                           |      |      |
| I <sub>i</sub>  | A or B<br>input           | V <sub>I</sub> = GND to 3.6 V  | 0 V to 3.6 V           |     |      | 0.1                            | 0.5  | μA   |
| I <sub>off</sub>  |                           | V <sub>I</sub> or V <sub>O</sub> = 0 V to 3.6 V                              | 0 V                    |     |      | 0.2                            | 0.6  | μA   |
| ΔI <sub>off</sub>   |                           | V <sub>I</sub> or V <sub>O</sub> = 0 V to 3.6 V                              | 0 V to 0.2 V           |     |      | 0.2                            | 0.6  | μA   |
| I <sub>CC</sub>   |                           | V <sub>I</sub> = GND or (V <sub>CC</sub> to 3.6 V),<br>I <sub>O</sub> = 0    | 0.8 V to 3.6 V         |     |      | 0.5                            | 0.9  | μA   |
| ΔI <sub>CC</sub>  |                           | V <sub>I</sub> = V <sub>CC</sub> – 0.6 V <sup>(1)</sup> , I <sub>O</sub> = 0 | 3.3 V                  |     |      | 40                             | 50   | μA   |
| C <sub>i</sub>  |                           | V <sub>I</sub> = V <sub>CC</sub> or GND                                      | 0 V                    |     |      | 1.5                            |      | pF   |
|   |                           |  | 3.6 V                  |     |      | 1.5                            |      |      |
| C <sub>o</sub>  |                           | V <sub>O</sub> = GND   | 0 V                    |     |      | 3                              |      | pF   |

 (1) One input at V<sub>CC</sub> – 0.6 V, other input at V<sub>CC</sub> or GND.

**SWITCHING CHARACTERISTICS**over recommended operating free-air temperature range,  $C_L = 5$  pF (unless otherwise noted) (see [Figure 3](#) and [Figure 4](#))

| PARAMETER | FROM<br>(INPUT) | TO<br>(OUTPUT) | $V_{CC}$                         | $T_A = 25^\circ\text{C}$ |     |      | $T_A = -40^\circ\text{C to } 85^\circ\text{C}$ |      | UNIT |
|-----------|-----------------|----------------|----------------------------------|--------------------------|-----|------|--|------|------|
|           |                 |                |                                  | MIN                      | TYP | MAX  | MIN  | MAX  |      |
| $t_{pd}$  | A               | Y              | 0.8 V                            | 18                       |     |      |  |      | ns   |
|           |                 |                | $1.2\text{ V} \pm 0.1\text{ V}$  | 2.6                      | 7.3 | 12.8 | 2.1  | 15.6 |      |
|           |                 |                | $1.5\text{ V} \pm 0.1\text{ V}$  | 1.4                      | 5.2 | 8.7  | 0.9  | 10.3 |      |
|           |                 |                | $1.8\text{ V} \pm 0.15\text{ V}$ | 1                        | 4.2 | 6.6  | 0.5  | 8.2  |      |
|           |                 |                | $2.5\text{ V} \pm 0.2\text{ V}$  | 1                        | 3   | 4.4  | 0.5  | 5.5  |      |
|           |                 |                | $3.3\text{ V} \pm 0.3\text{ V}$  | 1                        | 2.4 | 3.5  | 0.5  | 4.3  |      |

**SWITCHING CHARACTERISTICS**over recommended operating free-air temperature range,  $C_L = 10$  pF (unless otherwise noted) (see [Figure 3](#) and [Figure 4](#))

| PARAMETER | FROM<br>(INPUT) | TO<br>(OUTPUT) | $V_{CC}$                         | $T_A = 25^\circ\text{C}$ |     |      | $T_A = -40^\circ\text{C to } 85^\circ\text{C}$ |      | UNIT |
|-----------|-----------------|----------------|----------------------------------|--------------------------|-----|------|--|------|------|
|           |                 |                |                                  | MIN                      | TYP | MAX  | MIN  | MAX  |      |
| $t_{pd}$  | A               | Y              | 0.8 V                            | 18.4                     |     |      |  |      | ns   |
|           |                 |                | $1.2\text{ V} \pm 0.1\text{ V}$  | 4.6                      | 7.9 | 13.4 | 1.3  | 16.7 |      |
|           |                 |                | $1.5\text{ V} \pm 0.1\text{ V}$  | 4                        | 6   | 9.6  | 2.2  | 11.8 |      |
|           |                 |                | $1.8\text{ V} \pm 0.15\text{ V}$ | 3.6                      | 5   | 7.9  | 2.4  | 9.5  |      |
|           |                 |                | $2.5\text{ V} \pm 0.2\text{ V}$  | 3.2                      | 4   | 5.5  | 2.3  | 6.8  |      |
|           |                 |                | $3.3\text{ V} \pm 0.3\text{ V}$  | 2.9                      | 3.5 | 4.6  | 2.1  | 5.6  |      |

**SWITCHING CHARACTERISTICS**over recommended operating free-air temperature range,  $C_L = 15$  pF (unless otherwise noted) (see [Figure 3](#) and [Figure 4](#))

| PARAMETER | FROM<br>(INPUT) | TO<br>(OUTPUT) | $V_{CC}$                         | $T_A = 25^\circ\text{C}$ |     |      | $T_A = -40^\circ\text{C to } 85^\circ\text{C}$ |      | UNIT |
|-----------|-----------------|----------------|----------------------------------|--------------------------|-----|------|--|------|------|
|           |                 |                |                                  | MIN                      | TYP | MAX  | MIN  | MAX  |      |
| $t_{pd}$  | A               | Y              | 0.8 V                            | 24                       |     |      |  |      | ns   |
|           |                 |                | $1.2\text{ V} \pm 0.1\text{ V}$  | 3.6                      | 9.9 | 16.3 | 3.1  | 19.9 |      |
|           |                 |                | $1.5\text{ V} \pm 0.1\text{ V}$  | 2.3                      | 7.2 | 11.1 | 1.8  | 13.2 |      |
|           |                 |                | $1.8\text{ V} \pm 0.15\text{ V}$ | 1.6                      | 5.8 | 8.7  | 1.1  | 10.6 |      |
|           |                 |                | $2.5\text{ V} \pm 0.2\text{ V}$  | 1                        | 4.3 | 5.9  | 0.5  | 7.3  |      |
|           |                 |                | $3.3\text{ V} \pm 0.3\text{ V}$  | 1                        | 3.4 | 4.8  | 0.5  | 5.9  |      |

**SWITCHING CHARACTERISTICS**over recommended operating free-air temperature range,  $C_L = 30$  pF (unless otherwise noted) (see [Figure 3](#) and [Figure 4](#))

| PARAMETER | FROM<br>(INPUT) | TO<br>(OUTPUT) | $V_{CC}$                         | $T_A = 25^\circ\text{C}$ |      |      | $T_A = -40^\circ\text{C to } 85^\circ\text{C}$ |      | UNIT |
|-----------|-----------------|----------------|----------------------------------|--------------------------|------|------|--|------|------|
|           |                 |                |                                  | MIN                      | TYP  | MAX  | MIN  | MAX  |      |
| $t_{pd}$  | A               | Y              | 0.8 V                            | 32.8                     |      |      |  |      | ns   |
|           |                 |                | $1.2\text{ V} \pm 0.1\text{ V}$  | 4.9                      | 13.1 | 20.9 | 4.4  | 25.5 |      |
|           |                 |                | $1.5\text{ V} \pm 0.1\text{ V}$  | 3.4                      | 9.5  | 14.2 | 2.9  | 16.9 |      |
|           |                 |                | $1.8\text{ V} \pm 0.15\text{ V}$ | 2.5                      | 7.7  | 11   | 2  | 13.5 |      |
|           |                 |                | $2.5\text{ V} \pm 0.2\text{ V}$  | 1.8                      | 5.7  | 7.6  | 1.3  | 9.4  |      |
|           |                 |                | $3.3\text{ V} \pm 0.3\text{ V}$  | 1.5                      | 4.7  | 6.2  | 1  | 7.5  |      |

**OPERATING CHARACTERISTICS**
 $T_A = 25^\circ\text{C}$ 

| PARAMETER |                               | TEST CONDITIONS      | $V_{CC}$                           | TYP | UNIT |
|-----------|-------------------------------|----------------------|------------------------------------|-----|------|
| $C_{pd}$  | Power dissipation capacitance | $f = 10 \text{ MHz}$ | 0.8 V                              | 4   | pF   |
|           |                               |                      | $1.2 \text{ V} \pm 0.1 \text{ V}$  | 4   |      |
|           |                               |                      | $1.5 \text{ V} \pm 0.1 \text{ V}$  | 4   |      |
|           |                               |                      | $1.8 \text{ V} \pm 0.15 \text{ V}$ | 4   |      |
|           |                               |                      | $2.5 \text{ V} \pm 0.2 \text{ V}$  | 4.1 |      |
|           |                               |                      | $3.3 \text{ V} \pm 0.3 \text{ V}$  | 4.3 |      |

### PARAMETER MEASUREMENT INFORMATION (Propagation Delays, Setup and Hold Times, and Pulse Width)

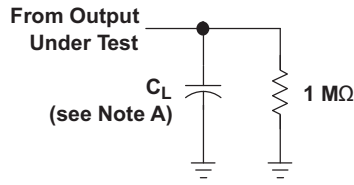

LOAD CIRCUIT

|       | $V_{CC} = 0.8\text{ V}$ | $V_{CC} = 1.2\text{ V}$<br>$\pm 0.1\text{ V}$ | $V_{CC} = 1.5\text{ V}$<br>$\pm 0.1\text{ V}$ | $V_{CC} = 1.8\text{ V}$<br>$\pm 0.15\text{ V}$ | $V_{CC} = 2.5\text{ V}$<br>$\pm 0.2\text{ V}$ | $V_{CC} = 3.3\text{ V}$<br>$\pm 0.3\text{ V}$ |
|-------|-------------------------|---|---|--|---|---|
| $C_L$ | 5, 10, 15, 30 pF        | 5, 10, 15, 30 pF                              | 5, 10, 15, 30 pF                              | 5, 10, 15, 30 pF                               | 5, 10, 15, 30 pF                              | 5, 10, 15, 30 pF                              |
| $V_M$ | $V_{CC}/2$              | $V_{CC}/2$                                    | $V_{CC}/2$                                    | $V_{CC}/2$                                     | $V_{CC}/2$                                    | $V_{CC}/2$                                    |
| $V_I$ | $V_{CC}$                | $V_{CC}$                                      | $V_{CC}$                                      | $V_{CC}$                                       | $V_{CC}$                                      | $V_{CC}$                                      |

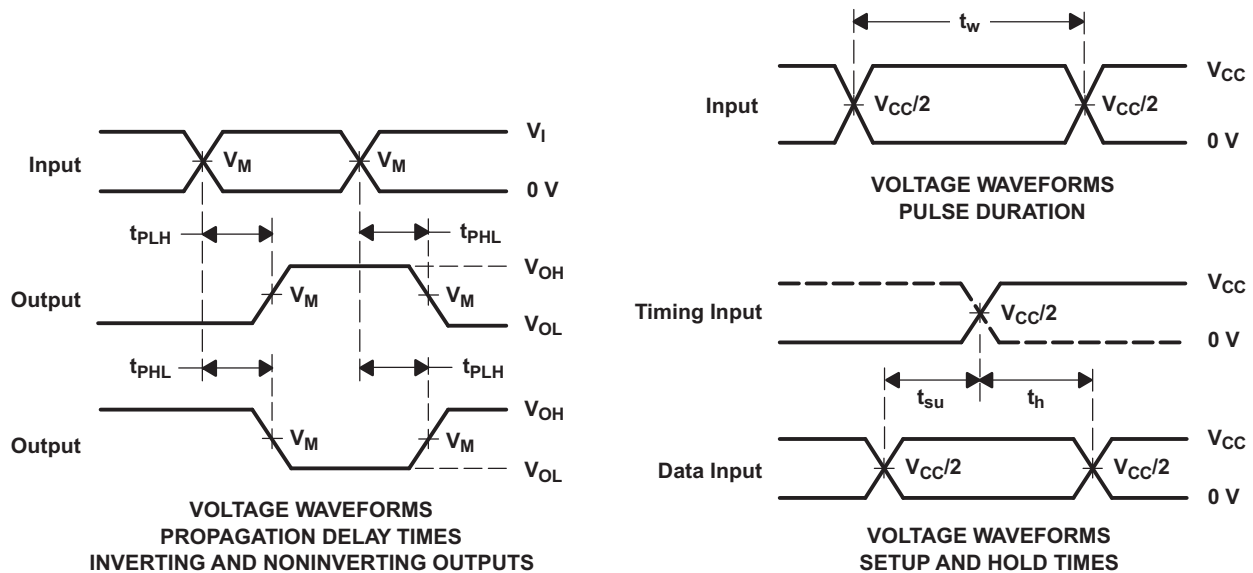

- A.  $C_L$  includes probe and jig capacitance.
- B. Waveform 1 is for an output with internal conditions such that the output is low, except when disabled by the output control. Waveform 2 is for an output with internal conditions such that the output is high, except when disabled by the output control.
- C. All input pulses are supplied by generators having the following characteristics: PRR  $\leq 10\text{ MHz}$ ,  $Z_O = 50\ \Omega$ , for propagation delays  $t_r/t_f = 3\text{ ns}$ , for setup and hold times and pulse width  $t_r/t_f = 1.2\text{ ns}$ .
- D. The outputs are measured one at a time, with one transition per measurement.
- E.  $t_{PLH}$  and  $t_{PHL}$  are the same as  $t_{pd}$ .
- F. All parameters and waveforms are not applicable to all devices.

Figure 3. Load Circuit and Voltage Waveforms

**PARAMETER MEASUREMENT INFORMATION  
(Enable and Disable Times)**

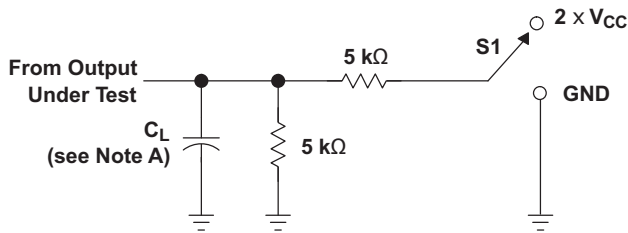

| TEST              | S1                |
|-------------------|-------------------|
| $t_{PLZ}/t_{PZL}$ | 2 $\times V_{CC}$ |
| $t_{PHZ}/t_{PZH}$ | GND               |

**LOAD CIRCUIT**

|              | $V_{CC} = 0.8\text{ V}$ | $V_{CC} = 1.2\text{ V}$<br>$\pm 0.1\text{ V}$ | $V_{CC} = 1.5\text{ V}$<br>$\pm 0.1\text{ V}$ | $V_{CC} = 1.8\text{ V}$<br>$\pm 0.15\text{ V}$ | $V_{CC} = 2.5\text{ V}$<br>$\pm 0.2\text{ V}$ | $V_{CC} = 3.3\text{ V}$<br>$\pm 0.3\text{ V}$ |
|--------------|-------------------------|---|---|--|---|---|
| $C_L$        | 5, 10, 15, 30 pF        | 5, 10, 15, 30 pF                              | 5, 10, 15, 30 pF                              | 5, 10, 15, 30 pF                               | 5, 10, 15, 30 pF                              | 5, 10, 15, 30 pF                              |
| $V_M$        | $V_{CC}/2$              | $V_{CC}/2$                                    | $V_{CC}/2$                                    | $V_{CC}/2$                                     | $V_{CC}/2$                                    | $V_{CC}/2$                                    |
| $V_I$        | $V_{CC}$                | $V_{CC}$                                      | $V_{CC}$                                      | $V_{CC}$                                       | $V_{CC}$                                      | $V_{CC}$                                      |
| $V_{\Delta}$ | 0.1 V                   | 0.1 V   | 0.1 V   | 0.15 V   | 0.15 V  | 0.3 V   |

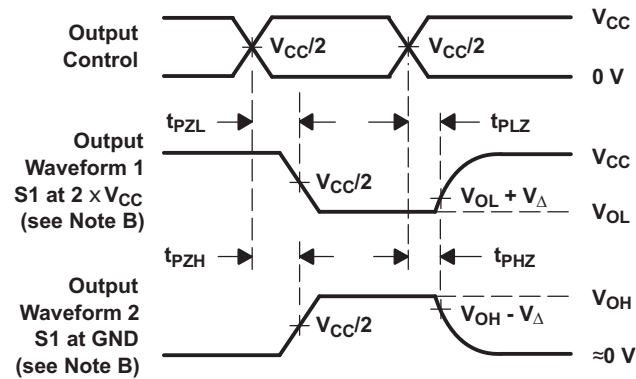

**VOLTAGE WAVEFORMS  
ENABLE AND DISABLE TIMES  
LOW- AND HIGH-LEVEL ENABLING**

- A.  $C_L$  includes probe and jig capacitance.
- B. Waveform 1 is for an output with internal conditions such that the output is low, except when disabled by the output control. Waveform 2 is for an output with internal conditions such that the output is high, except when disabled by the output control.
- C. All input pulses are supplied by generators having the following characteristics: PRR  $\leq$  10 MHz,  $Z_O = 50\ \Omega$ ,  $t_r/t_f = 3\text{ ns}$ .
- D. The outputs are measured one at a time, with one transition per measurement.
- E.  $t_{PLZ}$  and  $t_{PHZ}$  are the same as  $t_{dis}$ .
- F.  $t_{PLH}$  and  $t_{PHL}$  are the same as  $t_{pd}$ .
- G. All parameters and waveforms are not applicable to all devices.

**Figure 4. Load Circuit and Voltage Waveforms**

## REVISION HISTORY

| Changes from Revision B (March 2012) to Revision C | Page              |
|--|-------------------|
| • Updated ORDERING INFORMATION table. ....         | <a href="#">2</a> |

**PACKAGING INFORMATION**

| Orderable Device | Status<br>(1) | Package Type | Package Drawing | Pins | Package Qty | Eco Plan<br>(2)         | Lead/Ball Finish<br>(6)    | MSL Peak Temp<br>(3) | Op Temp (°C) | Device Marking<br>(4/5) | Samples                 |
|------------------|---------------|--------------|-----------------|------|-------------|-------------------------|----------------------------|----------------------|--------------|-------------------------|-------------------------|
| SN74AUP2G14DCKR  | ACTIVE        | SC70         | DCK             | 6    | 3000        | Green (RoHS & no Sb/Br) | CU NIPDAU                  | Level-1-260C-UNLIM   | -40 to 85    | (H65 ~ H6F)             | <a href="#">Samples</a> |
| SN74AUP2G14DRYR  | ACTIVE        | SON          | DRY             | 6    | 5000        | Green (RoHS & no Sb/Br) | CU NIPDAU                  | Level-1-260C-UNLIM   | -40 to 85    | H6                      | <a href="#">Samples</a> |
| SN74AUP2G14DSF2  | ACTIVE        | SON          | DSF             | 6    | 5000        | Green (RoHS & no Sb/Br) | CU NIPDAU                  | Level-1-260C-UNLIM   | -40 to 85    | H6                      | <a href="#">Samples</a> |
| SN74AUP2G14DSFR  | ACTIVE        | SON          | DSF             | 6    | 5000        | Green (RoHS & no Sb/Br) | CU NIPDAU  <br>CU NIPDAUAG | Level-1-260C-UNLIM   | -40 to 85    | H6                      | <a href="#">Samples</a> |
| SN74AUP2G14YFPR  | ACTIVE        | DSBGA        | YFP             | 6    | 3000        | Green (RoHS & no Sb/Br) | SNAGCU                     | Level-1-260C-UNLIM   | -40 to 85    | HFN                     | <a href="#">Samples</a> |

(1) The marketing status values are defined as follows:

**ACTIVE:** Product device recommended for new designs.

**LIFEBUY:** TI has announced that the device will be discontinued, and a lifetime-buy period is in effect.

**NRND:** Not recommended for new designs. Device is in production to support existing customers, but TI does not recommend using this part in a new design.

**PREVIEW:** Device has been announced but is not in production. Samples may or may not be available.

**OBSOLETE:** TI has discontinued the production of the device.

(2) Eco Plan - The planned eco-friendly classification: Pb-Free (RoHS), Pb-Free (RoHS Exempt), or Green (RoHS & no Sb/Br) - please check <http://www.ti.com/productcontent> for the latest availability information and additional product content details.

**TBD:** The Pb-Free/Green conversion plan has not been defined.

**Pb-Free (RoHS):** TI's terms "Lead-Free" or "Pb-Free" mean semiconductor products that are compatible with the current RoHS requirements for all 6 substances, including the requirement that lead not exceed 0.1% by weight in homogeneous materials. Where designed to be soldered at high temperatures, TI Pb-Free products are suitable for use in specified lead-free processes.

**Pb-Free (RoHS Exempt):** This component has a RoHS exemption for either 1) lead-based flip-chip solder bumps used between the die and package, or 2) lead-based die adhesive used between the die and leadframe. The component is otherwise considered Pb-Free (RoHS compatible) as defined above.

**Green (RoHS & no Sb/Br):** TI defines "Green" to mean Pb-Free (RoHS compatible), and free of Bromine (Br) and Antimony (Sb) based flame retardants (Br or Sb do not exceed 0.1% by weight in homogeneous material)

(3) MSL, Peak Temp. - The Moisture Sensitivity Level rating according to the JEDEC industry standard classifications, and peak solder temperature.

(4) There may be additional marking, which relates to the logo, the lot trace code information, or the environmental category on the device.

(5) Multiple Device Markings will be inside parentheses. Only one Device Marking contained in parentheses and separated by a "~" will appear on a device. If a line is indented then it is a continuation of the previous line and the two combined represent the entire Device Marking for that device.

<sup>(6)</sup> Lead/Ball Finish - Orderable Devices may have multiple material finish options. Finish options are separated by a vertical ruled line. Lead/Ball Finish values may wrap to two lines if the finish value exceeds the maximum column width.

**Important Information and Disclaimer:**The information provided on this page represents TI's knowledge and belief as of the date that it is provided. TI bases its knowledge and belief on information provided by third parties, and makes no representation or warranty as to the accuracy of such information. Efforts are underway to better integrate information from third parties. TI has taken and continues to take reasonable steps to provide representative and accurate information but may not have conducted destructive testing or chemical analysis on incoming materials and chemicals. TI and TI suppliers consider certain information to be proprietary, and thus CAS numbers and other limited information may not be available for release.

In no event shall TI's liability arising out of such information exceed the total purchase price of the TI part(s) at issue in this document sold by TI to Customer on an annual basis.

## TAPE AND REEL INFORMATION

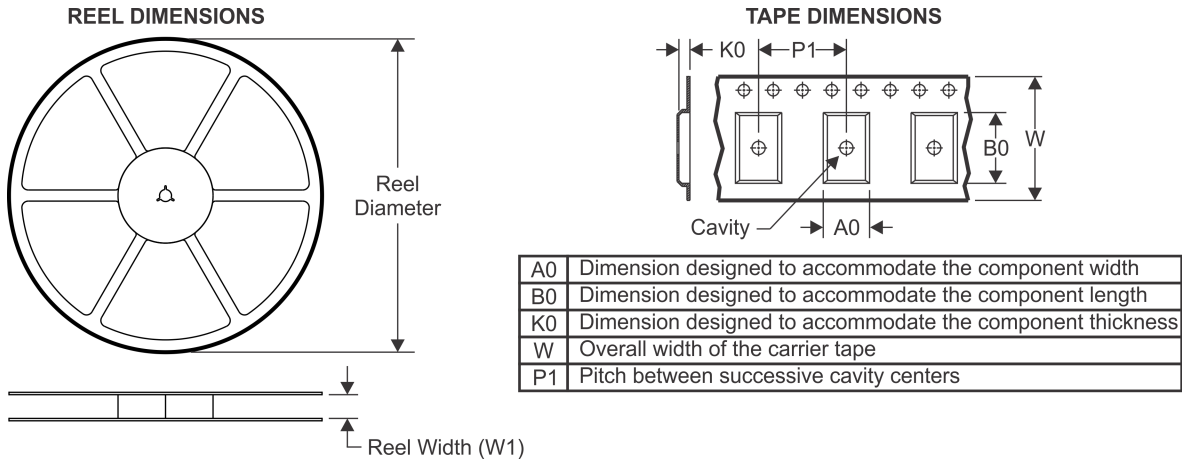

### QUADRANT ASSIGNMENTS FOR PIN 1 ORIENTATION IN TAPE



\*All dimensions are nominal

| Device          | Package Type | Package Drawing | Pins | SPQ  | Reel Diameter (mm) | Reel Width W1 (mm) | A0 (mm) | B0 (mm) | K0 (mm) | P1 (mm) | W (mm) | Pin1 Quadrant |
|-----------------|--------------|-----------------|------|------|--------------------|--------------------|---------|---------|---------|---------|--------|---------------|
| SN74AUP2G14DCKR | SC70         | DCK             | 6    | 3000 | 178.0              | 9.2                | 2.4     | 2.4     | 1.22    | 4.0     | 8.0    | Q3            |
| SN74AUP2G14DCKR | SC70         | DCK             | 6    | 3000 | 178.0              | 9.0                | 2.4     | 2.5     | 1.2     | 4.0     | 8.0    | Q3            |
| SN74AUP2G14DRYR | SON          | DRY             | 6    | 5000 | 180.0              | 9.5                | 1.15    | 1.6     | 0.75    | 4.0     | 8.0    | Q1            |
| SN74AUP2G14DSF2 | SON          | DSF             | 6    | 5000 | 180.0              | 9.5                | 1.16    | 1.16    | 0.5     | 4.0     | 8.0    | Q3            |
| SN74AUP2G14DSFR | SON          | DSF             | 6    | 5000 | 180.0              | 9.5                | 1.16    | 1.16    | 0.5     | 4.0     | 8.0    | Q2            |
| SN74AUP2G14YFPR | DSBGA        | YFP             | 6    | 3000 | 178.0              | 9.2                | 0.89    | 1.29    | 0.62    | 4.0     | 8.0    | Q1            |

**TAPE AND REEL BOX DIMENSIONS**

\*All dimensions are nominal

| Device          | Package Type | Package Drawing | Pins | SPQ  | Length (mm) | Width (mm) | Height (mm) |
|-----------------|--------------|-----------------|------|------|-------------|------------|-------------|
| SN74AUP2G14DCKR | SC70         | DCK             | 6    | 3000 | 180.0       | 180.0      | 18.0        |
| SN74AUP2G14DCKR | SC70         | DCK             | 6    | 3000 | 180.0       | 180.0      | 18.0        |
| SN74AUP2G14DRYR | SON          | DRY             | 6    | 5000 | 184.0       | 184.0      | 19.0        |
| SN74AUP2G14DSF2 | SON          | DSF             | 6    | 5000 | 184.0       | 184.0      | 19.0        |
| SN74AUP2G14DSFR | SON          | DSF             | 6    | 5000 | 184.0       | 184.0      | 19.0        |
| SN74AUP2G14YFPR | DSBGA        | YFP             | 6    | 3000 | 220.0       | 220.0      | 35.0        |

## GENERIC PACKAGE VIEW

**DRY 6**

**USON - 0.6 mm max height**

PLASTIC SMALL OUTLINE - NO LEAD



Images above are just a representation of the package family, actual package may vary.  
Refer to the product data sheet for package details.

4207181/G



# EXAMPLE BOARD LAYOUT

DRY0006A

USON - 0.6 mm max height

PLASTIC SMALL OUTLINE - NO LEAD

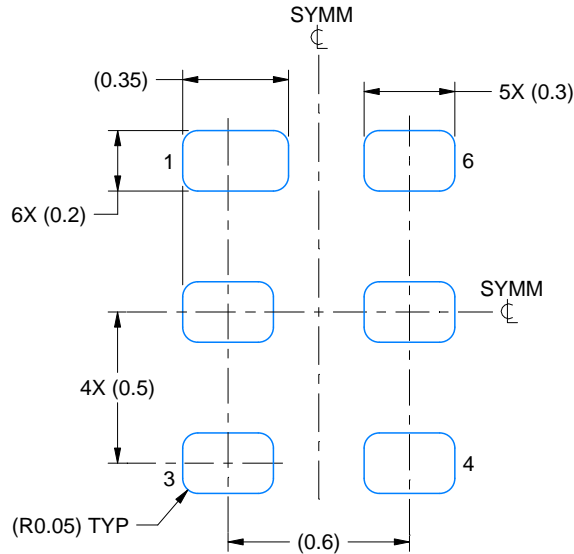

**LAND PATTERN EXAMPLE**  
 1:1 RATIO WITH PKG SOLDER PADS  
 EXPOSED METAL SHOWN  
 SCALE:40X

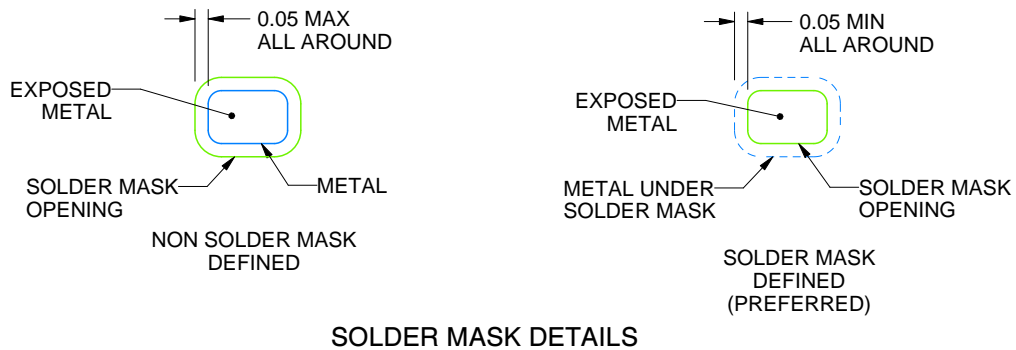

**SOLDER MASK DETAILS**

4222894/A 01/2018

NOTES: (continued)

3. For more information, see QFN/SON PCB application report in literature No. SLUA271 ([www.ti.com/lit/sluea271](http://www.ti.com/lit/sluea271)).

# EXAMPLE STENCIL DESIGN

DRY0006A

USON - 0.6 mm max height

PLASTIC SMALL OUTLINE - NO LEAD

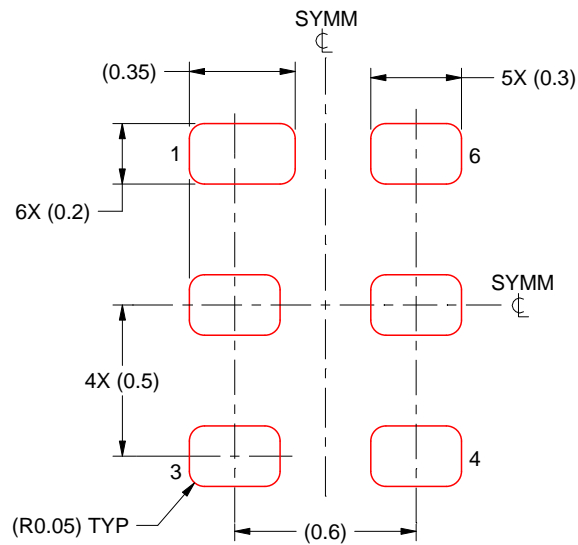

SOLDER PASTE EXAMPLE  
BASED ON 0.075 - 0.1 mm THICK STENCIL  
SCALE:40X

4222894/A 01/2018

NOTES: (continued)

4. Laser cutting apertures with trapezoidal walls and rounded corners may offer better paste release. IPC-7525 may have alternate design recommendations.

DCK (R-PDSO-G6)

PLASTIC SMALL-OUTLINE PACKAGE

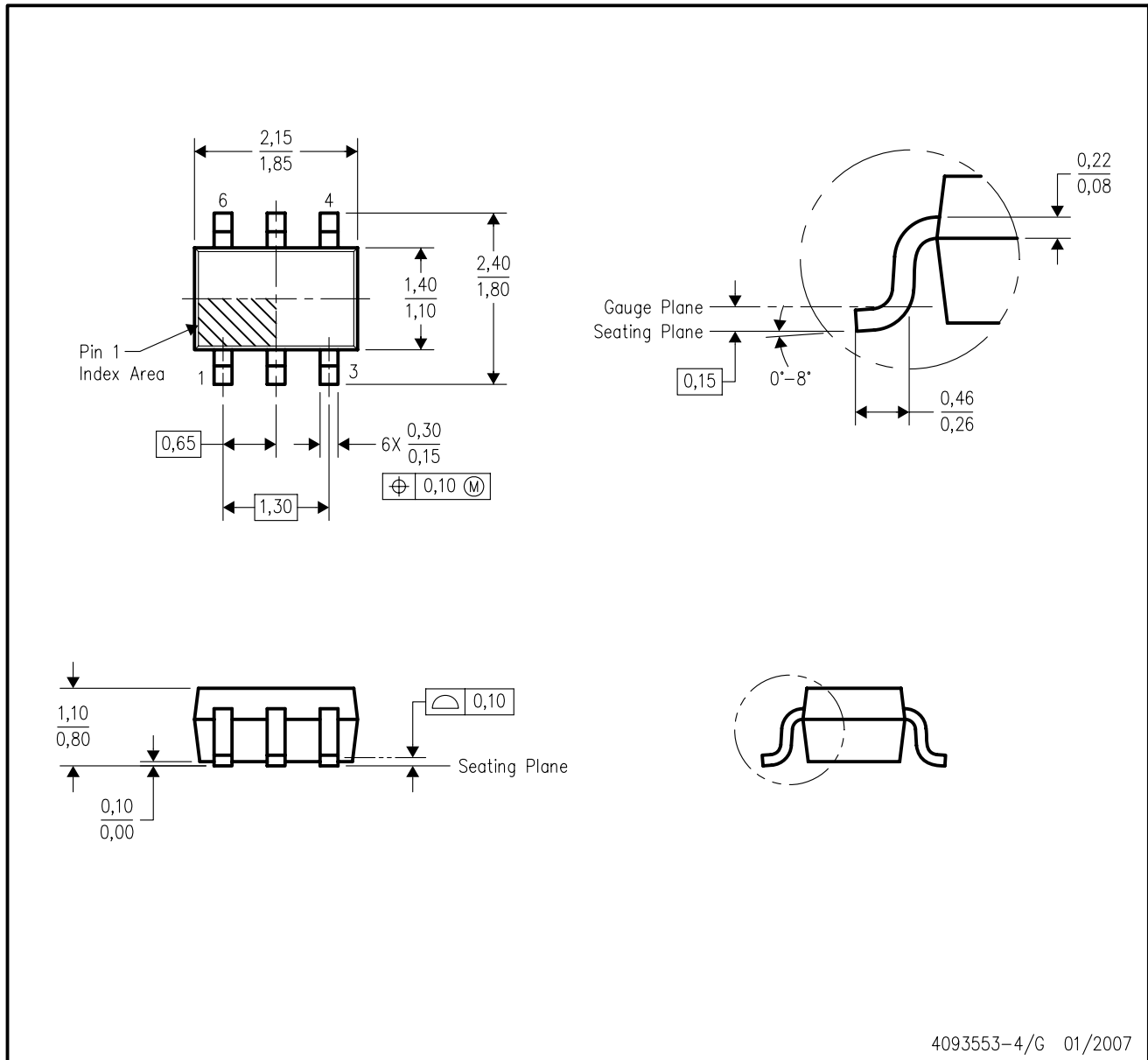

- NOTES:
- A. All linear dimensions are in millimeters.
  - B. This drawing is subject to change without notice.
  - C. Body dimensions do not include mold flash or protrusion. Mold flash and protrusion shall not exceed 0.15 per side.
  - D. Falls within JEDEC MO-203 variation AB.

DCK (R-PDSO-G6)

PLASTIC SMALL OUTLINE

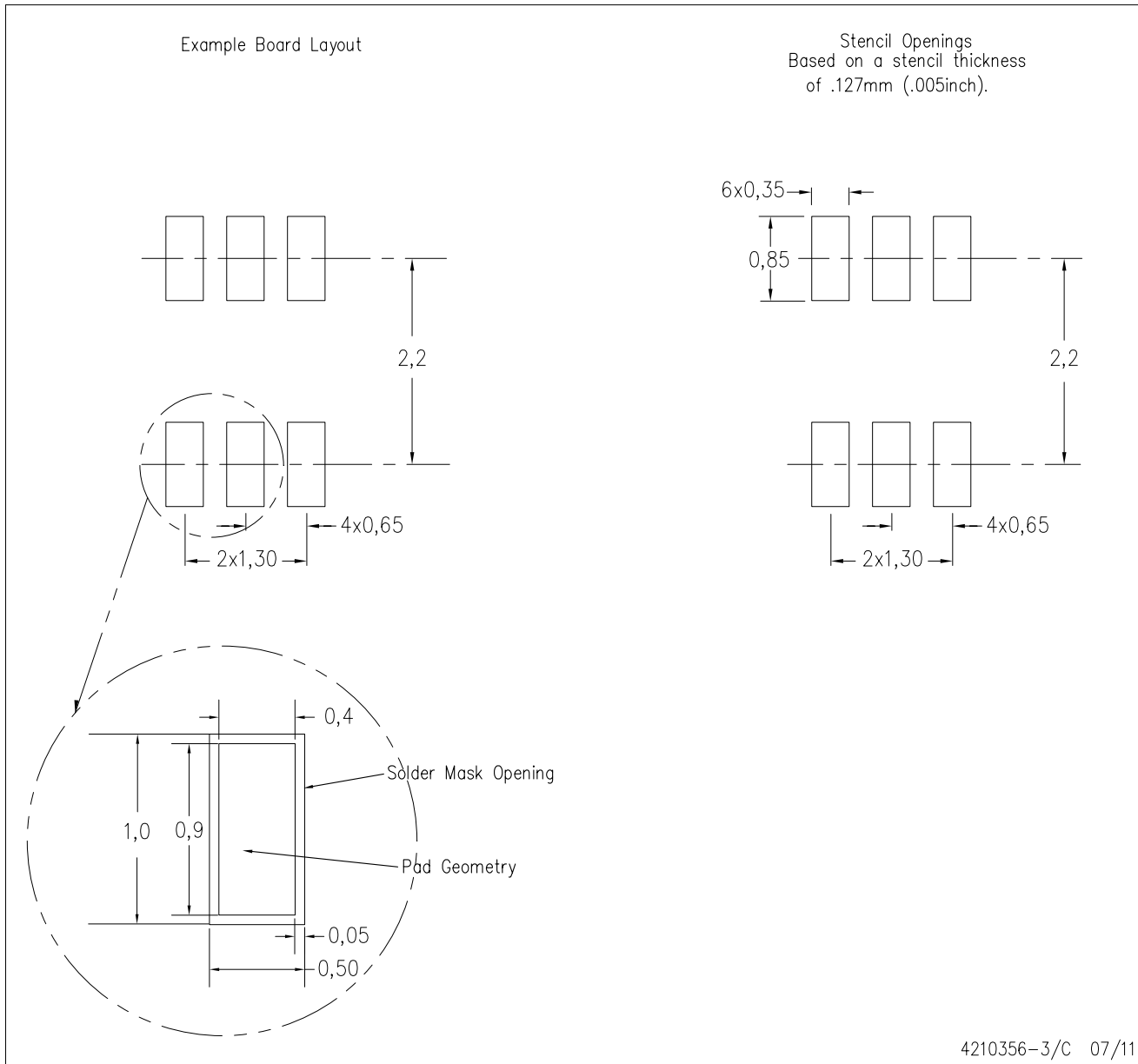

- NOTES:
- All linear dimensions are in millimeters.
  - This drawing is subject to change without notice.
  - Customers should place a note on the circuit board fabrication drawing not to alter the center solder mask defined pad.
  - Publication IPC-7351 is recommended for alternate designs.
  - Laser cutting apertures with trapezoidal walls and also rounding corners will offer better paste release. Customers should contact their board assembly site for stencil design recommendations. Example stencil design based on a 50% volumetric metal load solder paste. Refer to IPC-7525 for other stencil recommendations.

YFP0006



# PACKAGE OUTLINE

DSBGA - 0.5 mm max height

DIE SIZE BALL GRID ARRAY

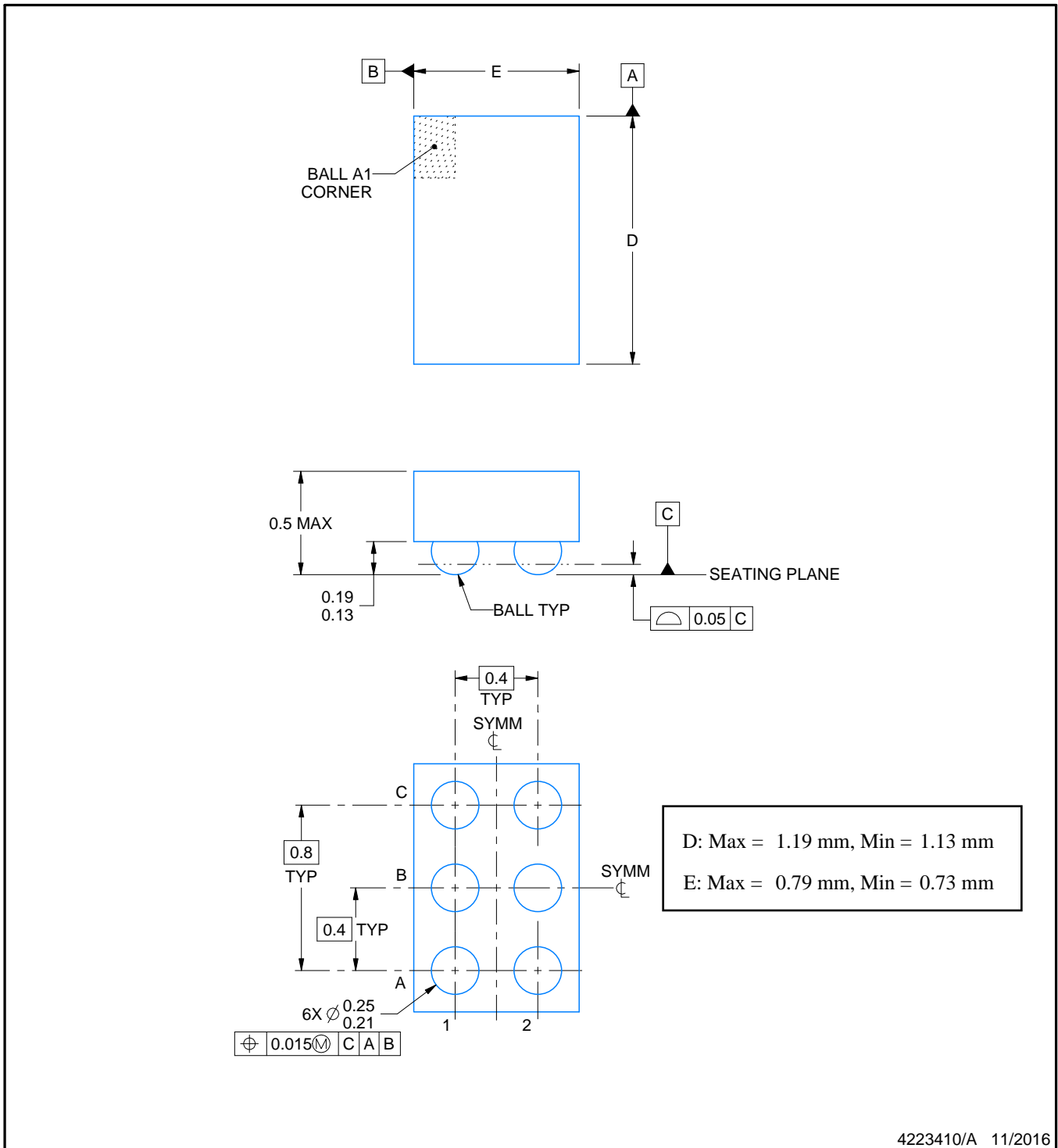

4223410/A 11/2016

NOTES:

1. All linear dimensions are in millimeters. Any dimensions in parenthesis are for reference only. Dimensioning and tolerancing per ASME Y14.5M.
2. This drawing is subject to change without notice.

# EXAMPLE BOARD LAYOUT

YFP0006

DSBGA - 0.5 mm max height

DIE SIZE BALL GRID ARRAY

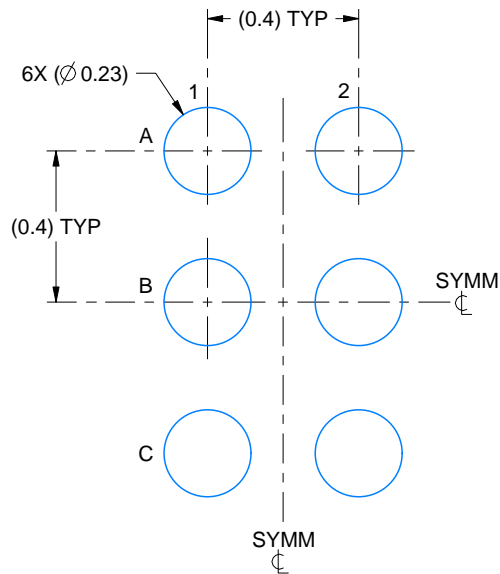

LAND PATTERN EXAMPLE  
SCALE:50X

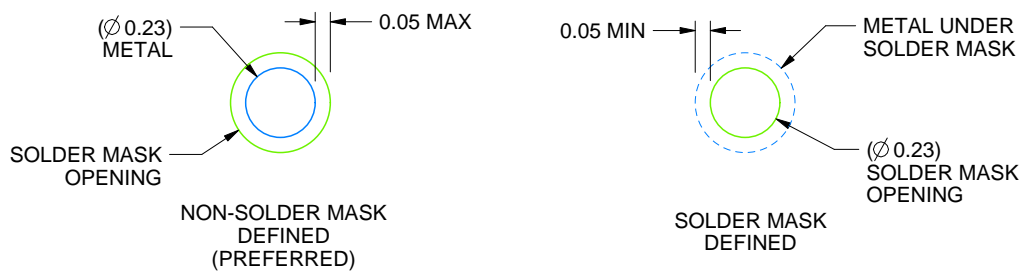

SOLDER MASK DETAILS  
NOT TO SCALE

4223410/A 11/2016

NOTES: (continued)

- Final dimensions may vary due to manufacturing tolerance considerations and also routing constraints. For more information, see Texas Instruments literature number SNVA009 ([www.ti.com/lit/snva009](http://www.ti.com/lit/snva009)).

# EXAMPLE STENCIL DESIGN

YFP0006

DSBGA - 0.5 mm max height

DIE SIZE BALL GRID ARRAY

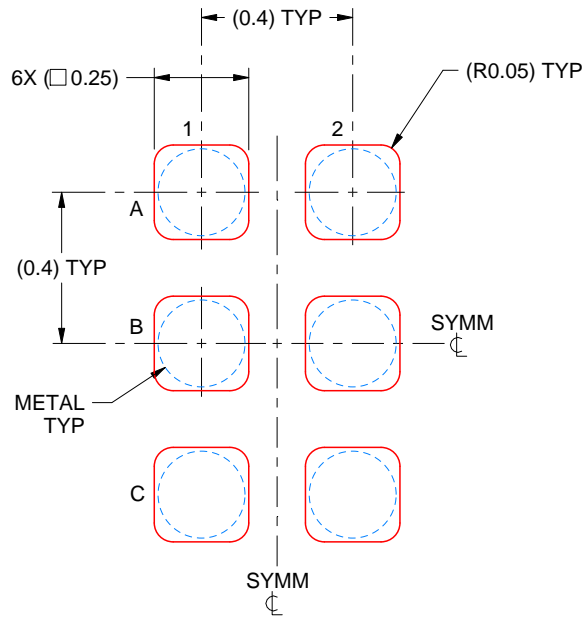

SOLDER PASTE EXAMPLE  
BASED ON 0.1 mm THICK STENCIL  
SCALE:50X

4223410/A 11/2016

NOTES: (continued)

4. Laser cutting apertures with trapezoidal walls and rounded corners may offer better paste release.

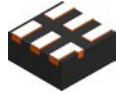

# DSF0006A

# PACKAGE OUTLINE

## X2SON - 0.4 mm max height

PLASTIC SMALL OUTLINE - NO LEAD

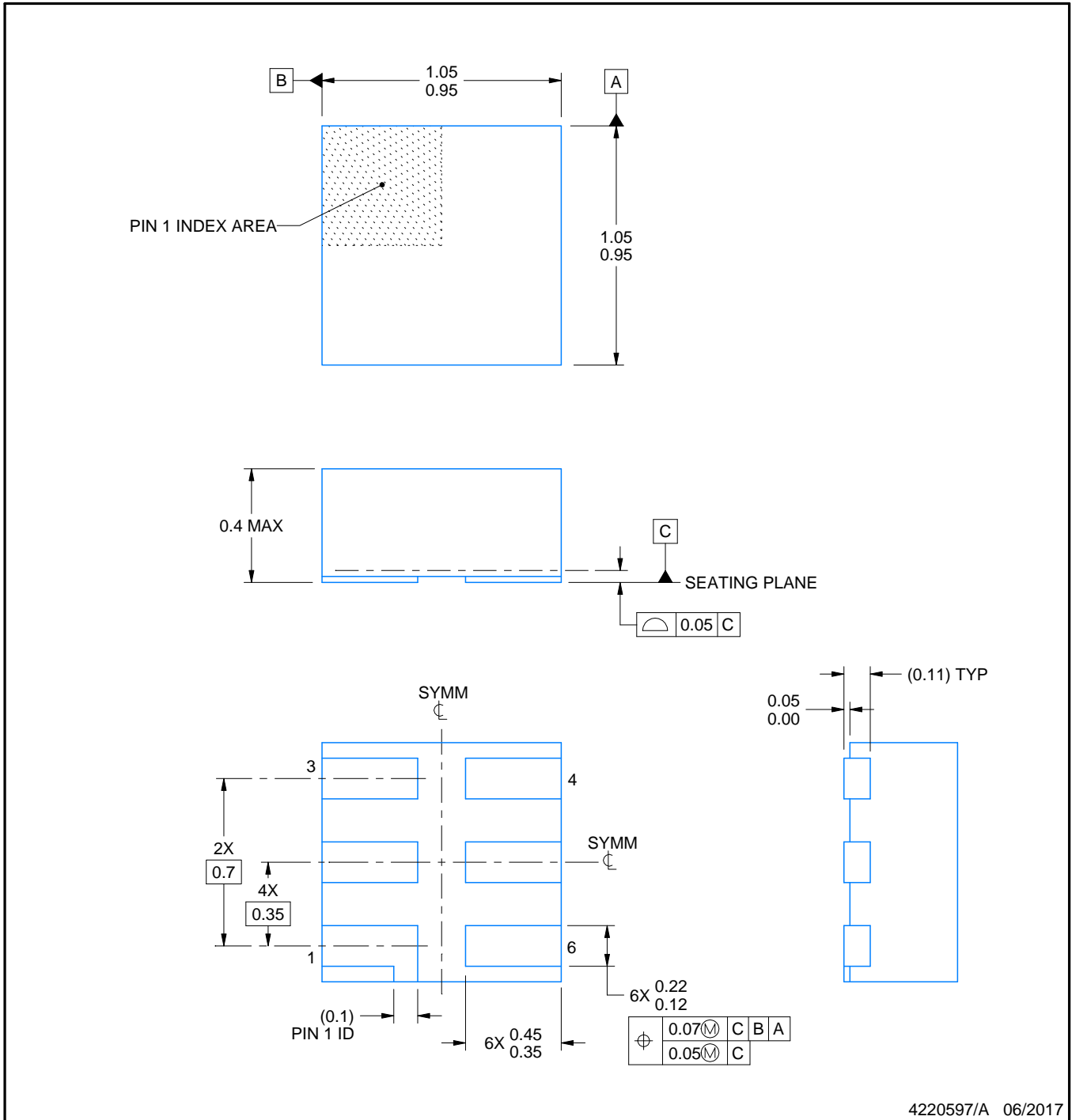

4220597/A 06/2017

### NOTES:

1. All linear dimensions are in millimeters. Any dimensions in parenthesis are for reference only. Dimensioning and tolerancing per ASME Y14.5M.
2. This drawing is subject to change without notice.
3. Reference JEDEC registration MO-287, variation X2AAF.

# EXAMPLE BOARD LAYOUT

DSF0006A

X2SON - 0.4 mm max height

PLASTIC SMALL OUTLINE - NO LEAD

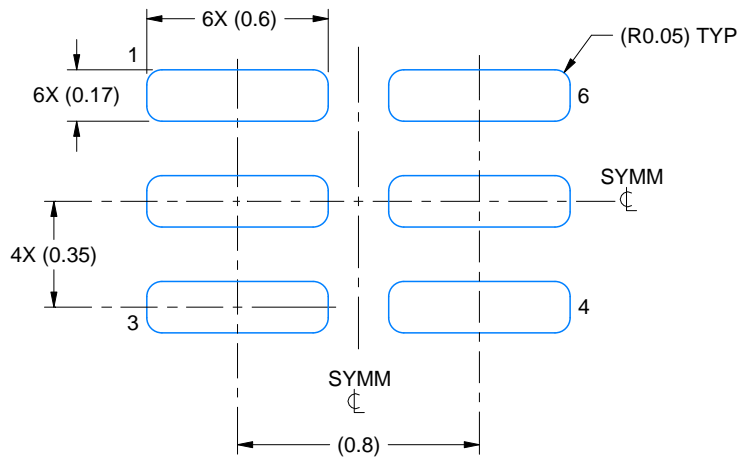

LAND PATTERN EXAMPLE  
EXPOSED METAL SHOWN  
SCALE:40X

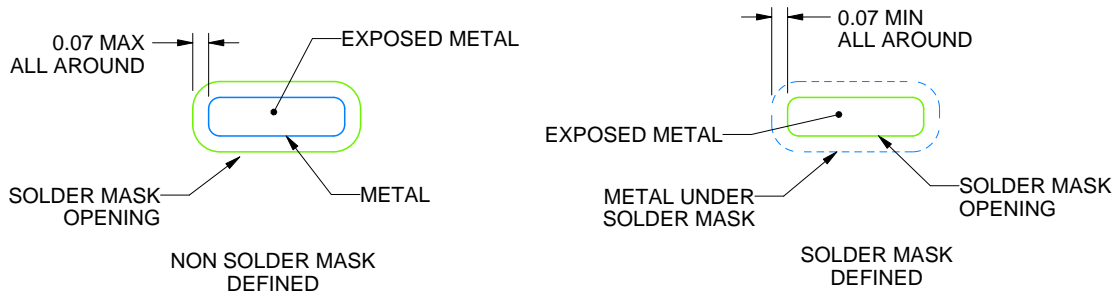

SOLDER MASK DETAILS

4220597/A 06/2017

NOTES: (continued)

4. For more information, see Texas Instruments literature number SLUA271 ([www.ti.com/lit/slua271](http://www.ti.com/lit/slua271)).

# EXAMPLE STENCIL DESIGN

DSF0006A

X2SON - 0.4 mm max height

PLASTIC SMALL OUTLINE - NO LEAD

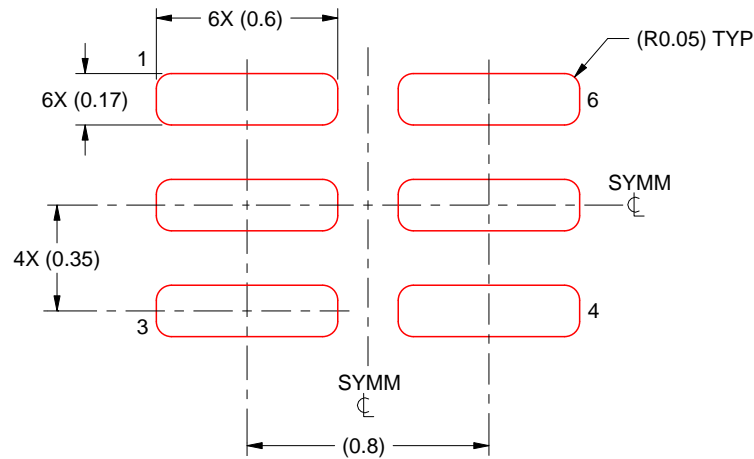

SOLDER PASTE EXAMPLE  
BASED ON 0.125 mm THICK STENCIL  
PRINTED SOLDER COVERAGE BY AREA UNDER PACKAGE  
SCALE:40X

4220597/A 06/2017

4. Laser cutting apertures with trapezoidal walls and rounded corners may offer better paste release. IPC-7525 may have alternate design recommendations.

## IMPORTANT NOTICE AND DISCLAIMER

TI PROVIDES TECHNICAL AND RELIABILITY DATA (INCLUDING DATASHEETS), DESIGN RESOURCES (INCLUDING REFERENCE DESIGNS), APPLICATION OR OTHER DESIGN ADVICE, WEB TOOLS, SAFETY INFORMATION, AND OTHER RESOURCES "AS IS" AND WITH ALL FAULTS, AND DISCLAIMS ALL WARRANTIES, EXPRESS AND IMPLIED, INCLUDING WITHOUT LIMITATION ANY IMPLIED WARRANTIES OF MERCHANTABILITY, FITNESS FOR A PARTICULAR PURPOSE OR NON-INFRINGEMENT OF THIRD PARTY INTELLECTUAL PROPERTY RIGHTS.

These resources are intended for skilled developers designing with TI products. You are solely responsible for (1) selecting the appropriate TI products for your application, (2) designing, validating and testing your application, and (3) ensuring your application meets applicable standards, and any other safety, security, or other requirements. These resources are subject to change without notice. TI grants you permission to use these resources only for development of an application that uses the TI products described in the resource. Other reproduction and display of these resources is prohibited. No license is granted to any other TI intellectual property right or to any third party intellectual property right. TI disclaims responsibility for, and you will fully indemnify TI and its representatives against, any claims, damages, costs, losses, and liabilities arising out of your use of these resources.

TI's products are provided subject to TI's Terms of Sale ([www.ti.com/legal/termsofsale.html](http://www.ti.com/legal/termsofsale.html)) or other applicable terms available either on [ti.com](http://ti.com) or provided in conjunction with such TI products. TI's provision of these resources does not expand or otherwise alter TI's applicable warranties or warranty disclaimers for TI products.

Mailing Address: Texas Instruments, Post Office Box 655303, Dallas, Texas 75265  
Copyright © 2018, Texas Instruments Incorporated

## Looking for pricing, stock, or lifecycle information?

Click below to explore more details on WIN SOURCE:

 [View SN74AUP2G14DCKR on WIN SOURCE](#)

 [Texas Instruments](#) Information

## Optimize Your Supply Chain with WIN SOURCE Solutions

-  Global Sourcing Solution
-  Obsolete Management
-  Cost Control Management
-  Shortage Management
-  Alternative Solution
-  Excess Inventory Management