

SNx4AHCT595 8-Bit Shift Registers With 3-State Output Registers

1 Features

- Inputs are TTL-Voltage Compatible
- 8-Bit Serial-In, Parallel-Out Shift
- Shift Register Has Direct Clear
- Latch-Up Performance Exceeds 100 mA Per JESD 78, Class II
- ESD Protection Exceeds JESD 22
 - 2000-V Human-Body Model (A114-A)
 - 200-V Machine Model (A115-A)
 - 1000-V Charged-Device Model (C101)

2 Applications

- Network Switches
- Power Infrastructures
- PCs and Notebooks
- LED Displays
- Servers

4 Simplified Schematic

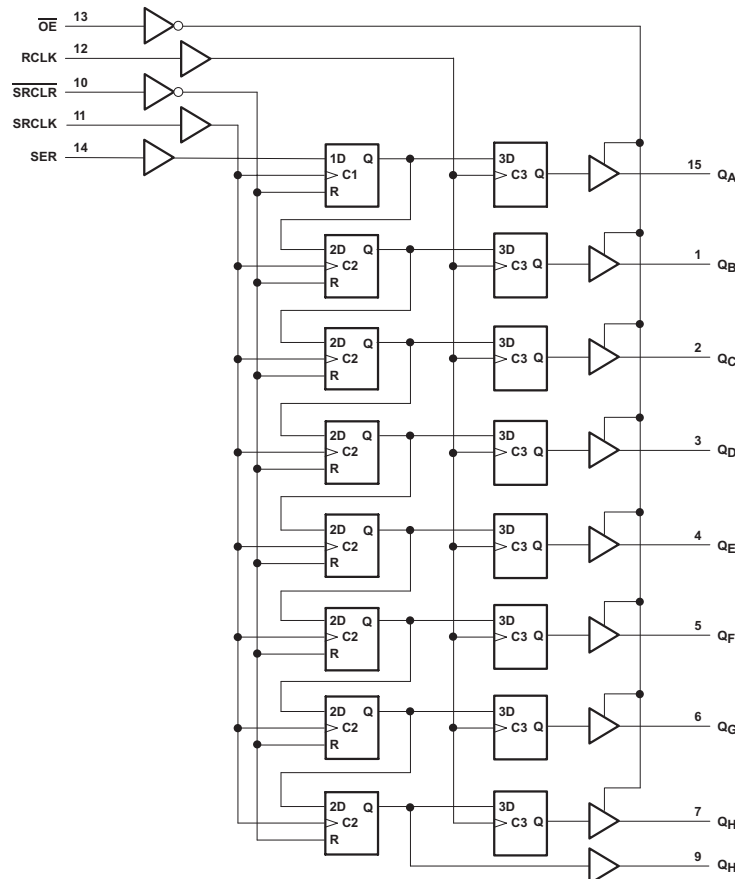

Pin numbers shown are for the D, DB, J, N, NS, PW, and W packages.

3 Description

The SNx4AHCT595 devices contain an 8-bit serial-in, parallel-out shift register that feeds an 8-bit D-type storage register. Both the shift register clock (SRCLK) and storage register clock (RCLK) are positive-edge triggered.

Device Information⁽¹⁾

| PART NUMBER | PACKAGE | BODY SIZE (NOM) |
|-------------|------------|--------------------|
| SNxAHCT595 | PDIP (20) | 24.33 mm 6.35 mm |
| | SOP (20) | 12.60 mm x 5.30 mm |
| | SSOP (20) | 7.50 mm x 5.30 mm |
| | TVSOP (20) | 5.00 mm x 4.40 mm |
| | SOIC (20) | 12.80 mm x 7.50 mm |

(1) For all available packages, see the orderable addendum at the end of the data sheet.



Table of Contents

| | | | |
|--|----------|--|-----------|
| 1 Features | 1 | 9 Detailed Description | 9 |
| 2 Applications | 1 | 9.1 Overview | 9 |
| 3 Description | 1 | 9.2 Functional Block Diagram | 9 |
| 4 Simplified Schematic | 1 | 9.3 Feature Description | 10 |
| 5 Revision History | 2 | 9.4 Device Functional Modes | 10 |
| 6 Pin Configuration and Functions | 3 | 10 Application and Implementation | 11 |
| 7 Specifications | 4 | 10.1 Application Information | 11 |
| 7.1 Absolute Maximum Ratings | 4 | 10.2 Typical Application | 11 |
| 7.2 Handling Ratings | 4 | 11 Power Supply Recommendations | 12 |
| 7.3 Recommended Operating Conditions | 4 | 12 Layout | 12 |
| 7.4 Thermal Information | 5 | 12.1 Layout Guidelines | 12 |
| 7.5 Electrical Characteristics | 5 | 12.2 Layout Example | 12 |
| 7.6 Timing Requirements | 5 | 13 Device and Documentation Support | 13 |
| 7.7 Switching Characteristics | 6 | 13.1 Related Links | 13 |
| 7.8 Noise Characteristics | 7 | 13.2 Trademarks | 13 |
| 7.9 Operating Characteristics | 7 | 13.3 Electrostatic Discharge Caution | 13 |
| 7.10 Typical Characteristics | 7 | 13.4 Glossary | 13 |
| 8 Parameter Measurement Information | 8 | 14 Mechanical, Packaging, and Orderable Information | 13 |

5 Revision History

NOTE: Page numbers for previous revisions may differ from page numbers in the current version.

| Changes from Revision M (July 2014) to Revision N | Page |
|--|-------------|
| • Changed Pin Functions table. | 3 |

| Changes from Revision L (February 2004) to Revision M | Page |
|--|-------------|
| • Updated document to new TI data sheet format. | 1 |
| • Removed Ordering Information table. | 1 |
| • Added Applications. | 1 |
| • Changed MAX operating temperature from 85°C to 125°C in Recommended Operating Conditions table. | 4 |
| • Added Typical Characteristics. | 7 |
| • Added Detailed Description section. | 9 |
| • Added Application and Implementation section. | 11 |

6 Pin Configuration and Functions

SN54AHCT595 . . . J OR W PACKAGE
SN74AHCT595 . . . D, DB, N, NS, OR PW PACKAGE
(TOP VIEW)

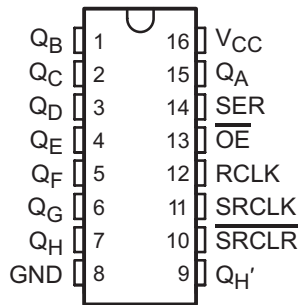

SN54AHCT595 . . . FK PACKAGE
(TOP VIEW)

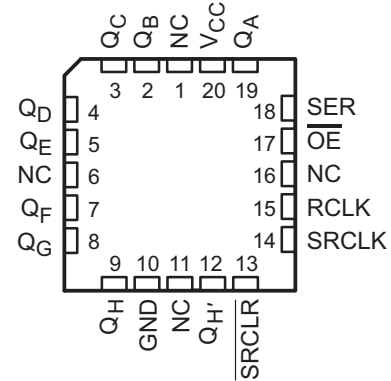

NC – No internal connection

Pin Functions

| NAME | PIN | | | I/O | DESCRIPTION |
|--------------------|---|---------------------|----|-----|--------------------------|
| | SN74AHCT595 D, DB, DGV, N, NS, PW | SN54AHCT595 J, W | FK | | |
| GND | 8 | 8 | 10 | — | Ground Pin |
| \overline{OE} | 13 | 13 | 17 | I | Output Enable |
| Q _A | 15 | 15 | 19 | O | Q _A Output |
| Q _B | 1 | 1 | 2 | O | Q _B Output |
| Q _C | 2 | 2 | 3 | O | Q _C Output |
| Q _D | 3 | 3 | 4 | O | Q _D Output |
| Q _E | 4 | 4 | 5 | O | Q _E Output |
| Q _F | 5 | 5 | 7 | O | Q _F Output |
| Q _G | 6 | 6 | 8 | O | Q _G Output |
| Q _H | 7 | 7 | 9 | O | Q _H Output |
| Q _{H'} | 9 | 9 | 12 | O | Q _{H'} Output |
| RCLK | 12 | 12 | 14 | I | RCLK Input |
| SER | 14 | 14 | 18 | I | SER Input |
| SRCLK | 11 | 11 | 14 | I | SRCLK Input |
| \overline{SRCLR} | 10 | 10 | 13 | I | \overline{SRCLR} Input |
| NC | | — | 1 | — | No Connection |
| | | | 6 | | |
| | | | 11 | | |
| | | | 16 | | |
| V _{CC} | 16 | 16 | 20 | — | Power Pin |

7 Specifications

7.1 Absolute Maximum Ratings

over operating free-air temperature range (unless otherwise noted)⁽¹⁾

| | | MIN | MAX | UNIT |
|---|-------------------------------------|--|-----------------------|--------|
| V _{CC} | Supply voltage range | −0.5 | 7 | V |
| V _I | Input voltage range ⁽²⁾ | −0.5 | 7 | V |
| V _O | Output voltage range ⁽²⁾ | −0.5 | V _{CC} + 0.5 | V |
| I _{IK} | Input clamp current | V _I < 0 | | −20 mA |
| I _{OK} | Output clamp current | V _O < 0 or V _O > V _{CC} | | ±20 mA |
| I _O | Continuous output current | V _O = 0 to V _{CC} | | ±25 mA |
| Continuous current through V _{CC} or GND | | | | ±50 mA |

- (1) Stresses beyond those listed under *Absolute Maximum Ratings* may cause permanent damage to the device. These are stress ratings only, which do not imply functional operation of the device at these or any other conditions beyond those indicated under *Recommended Operating Conditions*. Exposure to absolute-maximum-rated conditions for extended periods may affect device reliability.
- (2) The input and output voltage ratings may be exceeded if the input and output current ratings are observed.

7.2 Handling Ratings

| | | MIN | MAX | UNIT |
|--------------------|---------------------------|--|------|------|
| T _{stg} | Storage temperature range | −65 | 150 | °C |
| V _(ESD) | Electrostatic discharge | Human body model (HBM), per ANSI/ESDA/JEDEC JS-001, all pins ⁽¹⁾ | | V |
| | | Charged device model (CDM), per JEDEC specification JESD22-C101, all pins ⁽²⁾ | | |
| | | 0 | 2000 | |
| | | 0 | 1000 | |

- (1) JEDEC document JEP155 states that 500-V HBM allows safe manufacturing with a standard ESD control process.
- (2) JEDEC document JEP157 states that 250-V CDM allows safe manufacturing with a standard ESD control process.

7.3 Recommended Operating Conditions

over operating free-air temperature range (unless otherwise noted)⁽¹⁾

| | | SN54AHCT595 ⁽²⁾ | | SN74AHCT595 | | UNIT |
|-----------------|-------------------------------------|----------------------------|-----------------|-------------|-----------------|------|
| | | MIN | MAX | MIN | MAX | |
| V _{CC} | Supply voltage | 4.5 | 5.5 | 4.5 | 5.5 | V |
| V _{IH} | High-level input voltage | 2 | | 2 | | V |
| V _{IL} | Low-level input voltage | | 0.8 | | 0.8 | V |
| V _I | Input voltage | 0 | 5.5 | 0 | 5.5 | V |
| V _O | Output voltage | 0 | V _{CC} | 0 | V _{CC} | V |
| I _{OH} | High-level output current | | −8 | | −8 | mA |
| I _{OL} | Low-level output current | | 8 | | 8 | mA |
| Δt/Δv | Input transition rise and fall time | | 20 | | 20 | ns/V |
| T _A | Operating free-air temperature | −55 | 125 | −40 | 125 | °C |

- (1) All unused inputs of the device must be held at V_{CC} or GND to ensure proper device operation. Refer to the TI application report, *Implications of Slow or Floating CMOS Inputs*, literature number [SCBA004](#).
- (2) Product Preview

7.4 Thermal Information

| THERMAL METRIC ⁽¹⁾ | | SN74AHCT595 | | | | | UNIT |
|-------------------------------|--|-------------|------|------|------|-------|------|
| | | D | DB | N | NS | PW | |
| | | 16 PINS | | | | | |
| R _{θJA} | Junction-to-ambient thermal resistance | 80.2 | 97.5 | 47.5 | 79.1 | 105.7 | °C/W |
| R _{θJC(top)} | Junction-to-case (top) thermal resistance | 39.1 | 47.7 | 34.9 | 35.4 | 40.4 | |
| R _{θJB} | Junction-to-board thermal resistance | 27.7 | 48.1 | 27.5 | 39.9 | 50.7 | |
| ψ _{JT} | Junction-to-top characterization parameter | 9.9 | 9.8 | 19.8 | 5.4 | 3.7 | |
| ψ _{JB} | Junction-to-board characterization parameter | 37.4 | 47.6 | 27.4 | 39.5 | 50.1 | |
| R _{θJC(bot)} | Junction-to-case (bottom) thermal resistance | n/a | n/a | n/a | n/a | n/a | |

(1) For more information about traditional and new thermal metrics, see the *IC Package Thermal Metrics* application report, [SPRA953](#).

7.5 Electrical Characteristics

over operating free-air temperature range (unless otherwise noted)

| PARAMETER | TEST CONDITIONS | V _{CC} | T _A = 25°C | | | SN54AHCT595 ⁽¹⁾ | | SN74AHCT595 | | UNIT |
|---------------------------------|--|---------------------------------|-----------------------|-----|-------|----------------------------|-------------------|-------------|-----|------|
| | | | MIN | TYP | MAX | MIN | MAX | MIN | MAX | |
| V _{OH} | I _{OH} = –50 mA | 4.5 V | 4.4 | 4.5 | | 4.4 | | 4.4 | V | |
| | I _{OH} = –8 mA | | 3.94 | | | 3.8 | | 3.8 | | |
| V _{OL} | I _{OL} = 50 μA | 4.5 V | | | 0.1 | | | 0.1 | V | |
| | I _{OL} = 8 mA | | | | 0.36 | | 0.44 | 0.44 | | |
| I _I | V _I = 5.5 V or GND | 0 to 5.5 V | | | ±0.1 | | ±1 ⁽²⁾ | ±1 | μA | |
| I _{OZ} | V _O = V _{CC} or GND | Q _A – Q _H | | | ±0.25 | | ±2.5 | ±2.5 | μA | |
| I _{CC} | V _I = V _{CC} or GND | I _O = 0 | | | 4 | | 40 | 40 | μA | |
| ΔI _{CC} ⁽³⁾ | One input at 3.4V, Other inputs at V _{CC} or GND | | | | 2 | | 2.2 | 2.2 | mA | |
| C _i | V _I = V _{CC} or GND | 5 V | | 3 | 10 | | | 10 | pF | |
| C _o | V _O = V _{CC} or GND | 5 V | | 5.5 | | | | | pF | |

(1) Product Preview

(2) On products compliant to MIL-PRF-38535, this parameter is not production tested at V_{CC} = 0 V.

(3) This is the increase in supply current for each input at one of the specified TTL voltage levels, rather than 0 V or V_{CC}.

7.6 Timing Requirements

over recommended operating free-air temperature range, V_{CC} = 5 V ± 0.5 V (unless otherwise noted) (see [Figure 3](#))

| PARAMETER | | T _A = 25°C | | SN54AHCT595 ⁽¹⁾ | | SN74AHCT595 | | UNIT |
|-----------------|----------------|-------------------------------------|-----|----------------------------|-----|-------------|-----|------|
| | | MIN | MAX | MIN | MAX | MIN | MAX | |
| t _w | Pulse duration | SRCLK high or low | 5 | | 5.5 | | 5.5 | ns |
| | | RCLK high or low | 5 | | 5.5 | | 5.5 | |
| | | SRCLR low | 5 | | 5 | | 5 | |
| t _{su} | Setup time | SER before SRCLK↑ | 3 | | 3 | | 3 | ns |
| | | SRCLK↑ before RCLK↑ ⁽²⁾ | 5 | | 5 | | 5 | |
| | | SRCLR low before RCLK↑ | 5 | | 5 | | 5 | |
| | | SRCLR high (inactive) before SRCLK↑ | 3.4 | | 3.8 | | 3.8 | |
| t _h | Hold time | SER after SRCLK↑ | 2 | | 2 | | 2 | ns |

(1) Product Preview

(2) This setup time allows the storage register to receive stable data from the shift register. The clocks can be tied together, in which case the shift register is one clock pulse ahead of the storage register.

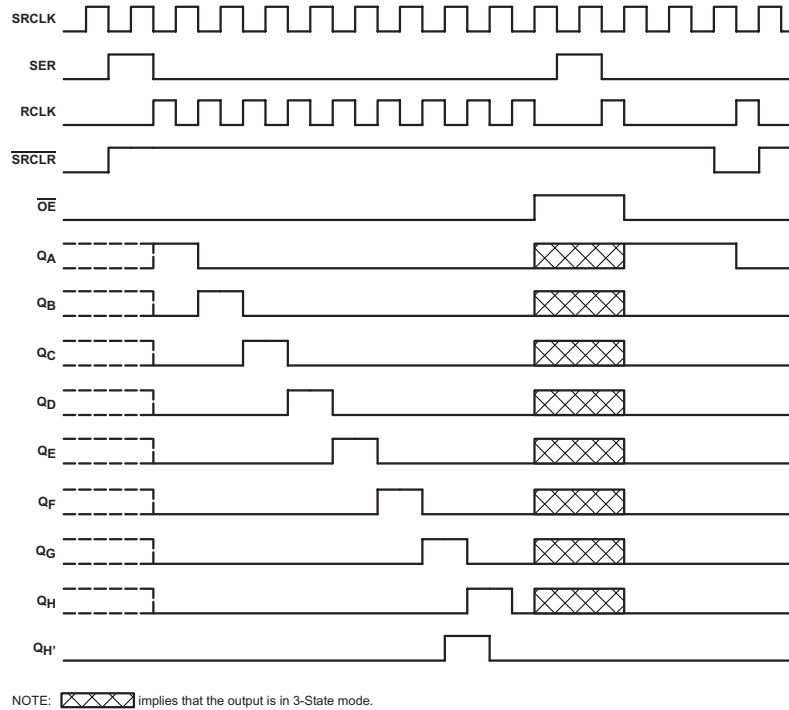
Figure 1. Timing Diagram

7.7 Switching Characteristics

 over recommended operating free-air temperature range, $V_{CC} = 5\text{ V} \pm 0.5\text{ V}$ (unless otherwise noted) (see [Figure 3](#))

| PARAMETER | FROM (INPUT) | TO (OUTPUT) | LOAD CAPACITANCE | $T_A = 25^\circ\text{C}$ | | | SN54AHCT595 ⁽¹⁾ | | SN74AHCT595 | | UNIT |
|------------------|---------------------------|-------------|----------------------|--------------------------|--------------------|--------------------|----------------------------|--------------------|-------------|------|------|
| | | | | MIN | TYP | MAX | MIN | MAX | MIN | MAX | |
| f_{max} | | | $C_L = 15\text{ pF}$ | 135 ⁽²⁾ | 170 ⁽²⁾ | | 115 ⁽²⁾ | | 115 | MHz | |
| | | | $C_L = 50\text{ pF}$ | 95 | 140 | | 85 | | 85 | | |
| t_{PLH} | RCLK | $Q_A - Q_H$ | $C_L = 15\text{ pF}$ | | 4.3 ⁽²⁾ | 7.4 ⁽²⁾ | 1 ⁽²⁾ | 8.5 ⁽²⁾ | 1 | 8.5 | ns |
| t_{PHL} | | | | | 4.3 ⁽²⁾ | 7.4 ⁽²⁾ | 1 ⁽²⁾ | 8.5 ⁽²⁾ | 1 | 8.5 | |
| t_{PLH} | SRCLK | $Q_{H'}$ | $C_L = 15\text{ pF}$ | | 4.5 ⁽²⁾ | 8.2 ⁽²⁾ | 1 ⁽²⁾ | 9.4 ⁽²⁾ | 1 | 9.4 | ns |
| t_{PHL} | | | | | 4.5 ⁽²⁾ | 8.2 ⁽²⁾ | 1 ⁽²⁾ | 9.4 ⁽²⁾ | 1 | 9.4 | |
| t_{PHL} | $\overline{\text{SRCLR}}$ | $Q_{H'}$ | $C_L = 15\text{ pF}$ | | 4.5 ⁽²⁾ | 8 ⁽²⁾ | 1 ⁽²⁾ | 9.1 ⁽²⁾ | 1 | 9.1 | ns |
| t_{PZH} | $\overline{\text{OE}}$ | $Q_A - Q_H$ | $C_L = 15\text{ pF}$ | | 4.3 ⁽²⁾ | 8.6 ⁽²⁾ | 1 ⁽²⁾ | 10 ⁽²⁾ | 1 | 10 | ns |
| t_{PZL} | | | | | 5.4 ⁽²⁾ | 8.6 ⁽²⁾ | 1 ⁽²⁾ | 10 ⁽²⁾ | 1 | 10 | |
| t_{PLH} | RCLK | $Q_A - Q_H$ | $C_L = 50\text{ pF}$ | | 5.6 | 9.4 | 1 | 10.5 | 1 | 10.5 | ns |
| t_{PHL} | | | | | 5.6 | 9.4 | 1 | 10.5 | 1 | 10.5 | |
| t_{PLH} | SRCLK | $Q_{H'}$ | $C_L = 50\text{ pF}$ | | 6.4 | 10.2 | 1 | 11.4 | 1 | 11.4 | ns |
| t_{PHL} | | | | | 6.4 | 10.2 | 1 | 11.4 | 1 | 11.4 | |
| t_{PHL} | $\overline{\text{SRCLR}}$ | $Q_{H'}$ | $C_L = 50\text{ pF}$ | | 6.4 | 10 | 1 | 11.1 | 1 | 11.1 | ns |
| t_{PZH} | $\overline{\text{OE}}$ | $Q_A - Q_H$ | $C_L = 50\text{ pF}$ | | 5.7 | 10.6 | 1 | 12 | 1 | 12 | ns |
| t_{PZL} | | | | | 6.8 | 10.6 | 1 | 12 | 1 | 12 | |
| t_{PHZ} | $\overline{\text{OE}}$ | $Q_A - Q_H$ | $C_L = 50\text{ pF}$ | | 3.5 | 10.3 | 1 | 11 | 1 | 11 | ns |
| t_{PLZ} | | | | | 3.4 | 10.3 | 1 | 11 | 1 | 11 | |

(1) Product Preview

(2) On products compliant to MIL-PRF-38535, this parameter is not production tested.

7.8 Noise Characteristics⁽¹⁾

$V_{CC} = 5\text{ V}$, $C_L = 50\text{ pF}$, $T_A = 25^\circ\text{C}$

| PARAMETER | | SN74AHCT595 | | | UNIT |
|-------------|--|-------------|------|-----|------|
| | | MIN | TYP | MAX | |
| $V_{OL(P)}$ | Quiet output, maximum dynamic V_{OL} | | 1 | | V |
| $V_{OL(V)}$ | Quiet output, minimum dynamic V_{OL} | | -0.6 | | V |
| $V_{OH(V)}$ | Quiet output, minimum dynamic V_{OH} | | 3.8 | | V |
| $V_{IH(D)}$ | High-level dynamic input voltage | 2 | | | V |
| $V_{IL(D)}$ | Low-level dynamic input voltage | | | 0.8 | V |

(1) Characteristics are for surface-mount packages only.

7.9 Operating Characteristics

$V_{CC} = 5\text{ V}$, $T_A = 25^\circ\text{C}$

| PARAMETER | TEST CONDITIONS | TYP | UNIT |
|-----------|-----------------------------|-----|------|
| C_{pd} | No load, $f = 1\text{ MHz}$ | 112 | pF |

7.10 Typical Characteristics

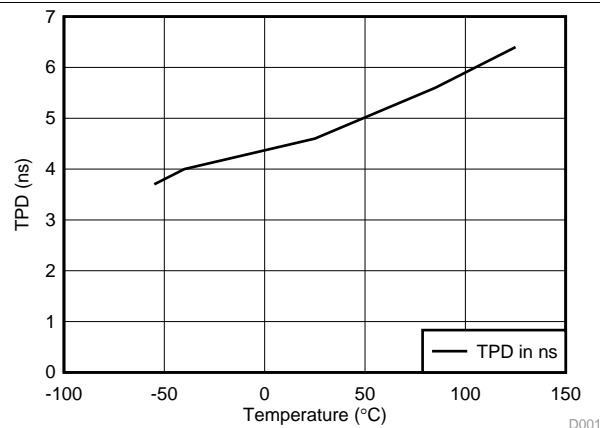
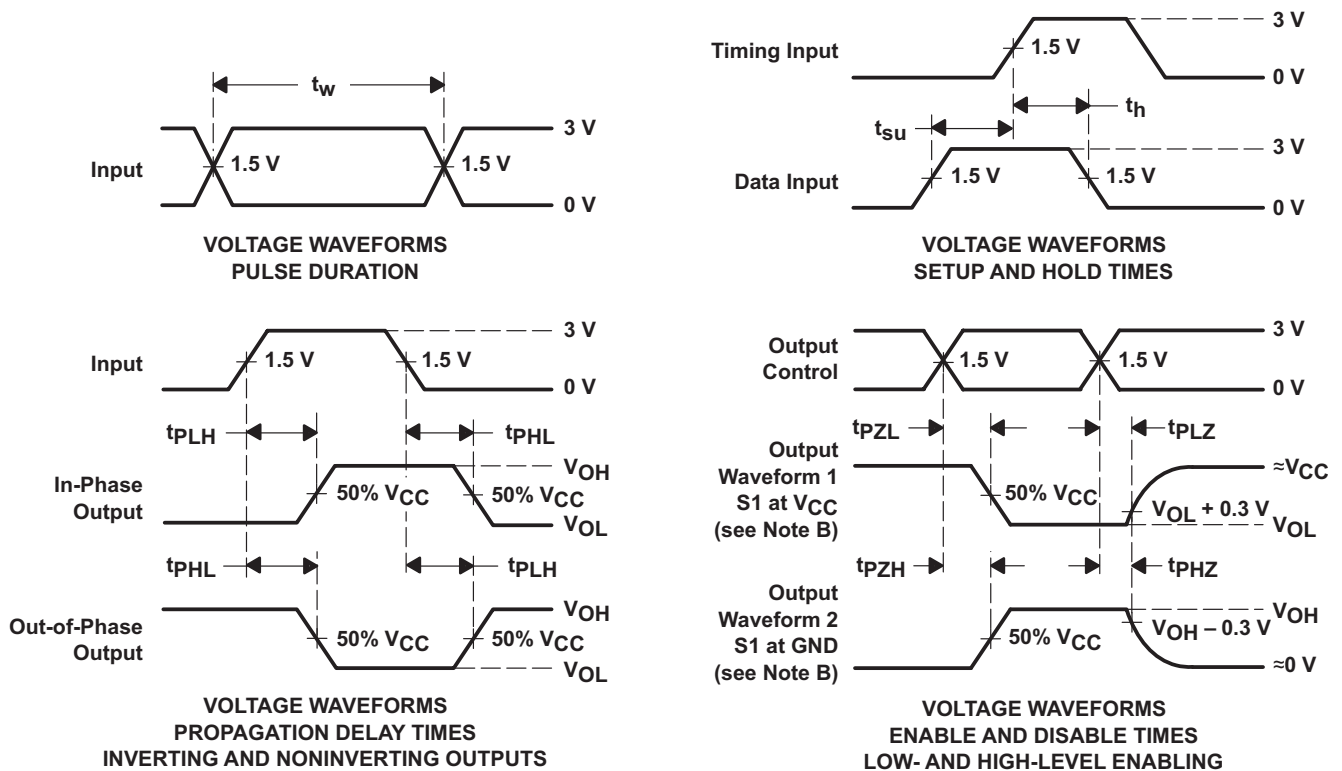
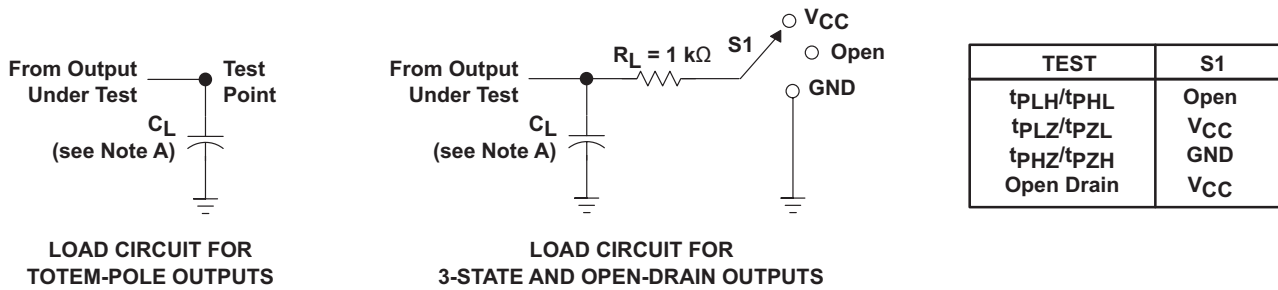

Figure 2. SN74AHCT595 TPD vs Temperature, 15 pF Load
RCLK to Q

8 Parameter Measurement Information



- NOTES: A. C_L includes probe and jig capacitance.
 B. Waveform 1 is for an output with internal conditions such that the output is low, except when disabled by the output control. Waveform 2 is for an output with internal conditions such that the output is high, except when disabled by the output control.
 C. All input pulses are supplied by generators having the following characteristics: $PRR \leq 1\text{ MHz}$, $Z_O = 50\ \Omega$, $t_r \leq 3\text{ ns}$, $t_f \leq 3\text{ ns}$.
 D. The outputs are measured one at a time, with one input transition per measurement.
 E. All parameters and waveforms are not applicable to all devices.

Figure 3. Load Circuit and Voltage Waveforms

9 Detailed Description

9.1 Overview

The SNx4AHCT595 devices contain an 8-bit serial-in, parallel-out shift register that feeds an 8-bit D-type storage register. The storage register has parallel 3-state outputs. Separate clocks are provided for the shift and storage registers. The shift register has a direct overriding clear (SRCLR) input, serial (SER) input, and serial outputs for cascading. When the output-enable (\overline{OE}) input is high, the outputs are in the high-impedance state. Both the shift register clock (SRCLK) and storage register clock (RCLK) are positive-edge triggered. If both clocks are connected together, the shift register always is one clock pulse ahead of the storage register.

9.2 Functional Block Diagram

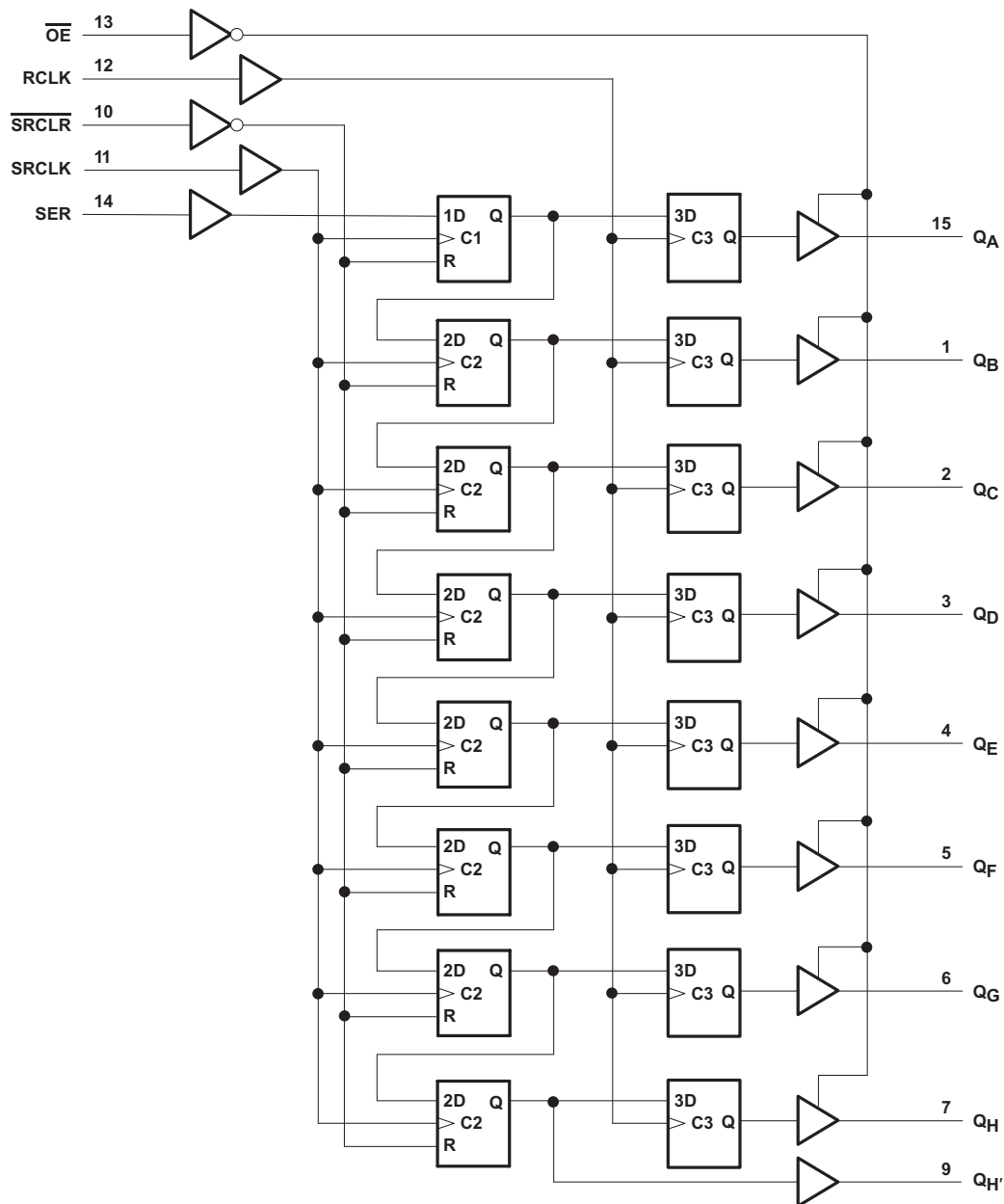

Pin numbers shown are for the D, DB, J, N, NS, PW, and W packages.

9.3 Feature Description

- Inputs are TTL-voltage compatible
- Slow edges for reduced noise
- Low power

9.4 Device Functional Modes

Table 1. Function Table

| INPUTS | | | | | FUNCTION |
|--------|-------|---------------------------|------|------------------------|--|
| SER | SRCLK | $\overline{\text{SRCLR}}$ | RCLK | $\overline{\text{OE}}$ | |
| X | X | X | X | H | Outputs $Q_A - Q_H$ are disabled. |
| X | X | X | X | L | Outputs $Q_A - Q_H$ are enabled. |
| X | X | L | X | X | Shift register is cleared. |
| L | ↑ | H | X | X | First stage of the shift register goes low. Other stages store the data of previous stage, respectively. |
| H | ↑ | H | X | X | First stage of the shift register goes high. Other stages store the data of previous stage, respectively. |
| X | X | X | ↑ | X | Shift-register data is stored in the storage register. |

10 Application and Implementation

10.1 Application Information

The SNx4AHCT595 is a low-drive CMOS device that can be used for a multitude of bus interface type applications where output ringing is a concern. The low drive and slow edge rates will minimize overshoot and undershoot on the outputs. The input switching levels have been lowered to accommodate TTL inputs of 0.8-V V_{IL} and 2-V V_{IH} . This feature makes it ideal for translating up from 3.3 V to 5 V. Figure 4 shows this type of translation.

10.2 Typical Application

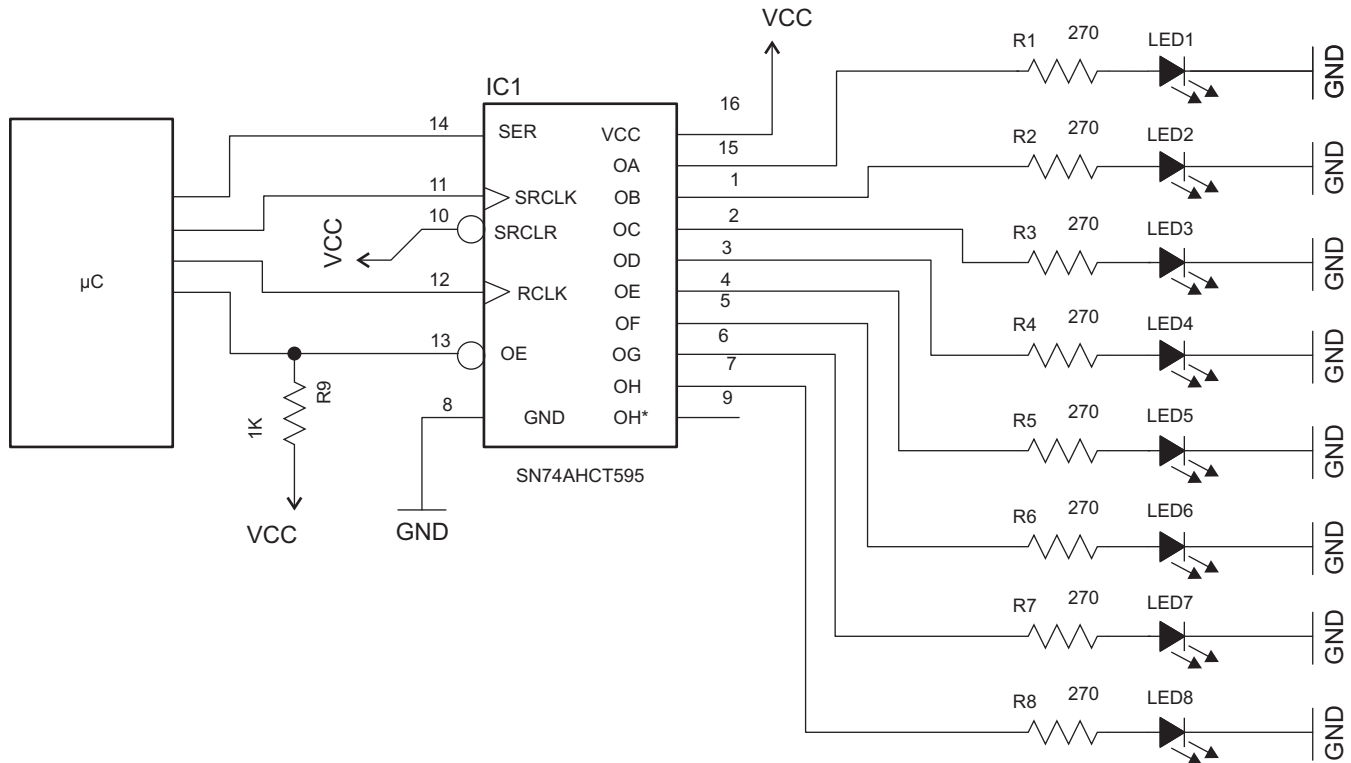

Figure 4. Specific Application Schematic

10.2.1 Design Requirements

This device uses CMOS technology and has balanced output drive. Care should be taken to avoid bus contention because it can drive currents that would exceed maximum limits. The high drive will also create fast edges into light loads so routing and load conditions should be considered to prevent ringing.

10.2.2 Detailed Design Procedure

- Recommended input conditions
 - Specified high and low levels. See (V_{IH} and V_{IL}) in the [Recommended Operating Conditions](#) table.
 - Specified high and low levels. See (V_{IH} and V_{IL}) in the [Recommended Operating Conditions](#) table.
 - Inputs are overvoltage tolerant allowing them to go as high as 5.5 V at any valid V_{CC}
- Recommend output conditions
 - Load currents should not exceed 25 mA per output and 50 mA total for the part
 - Outputs should not be pulled above V_{CC}

Typical Application (continued)

10.2.3 Application Curves

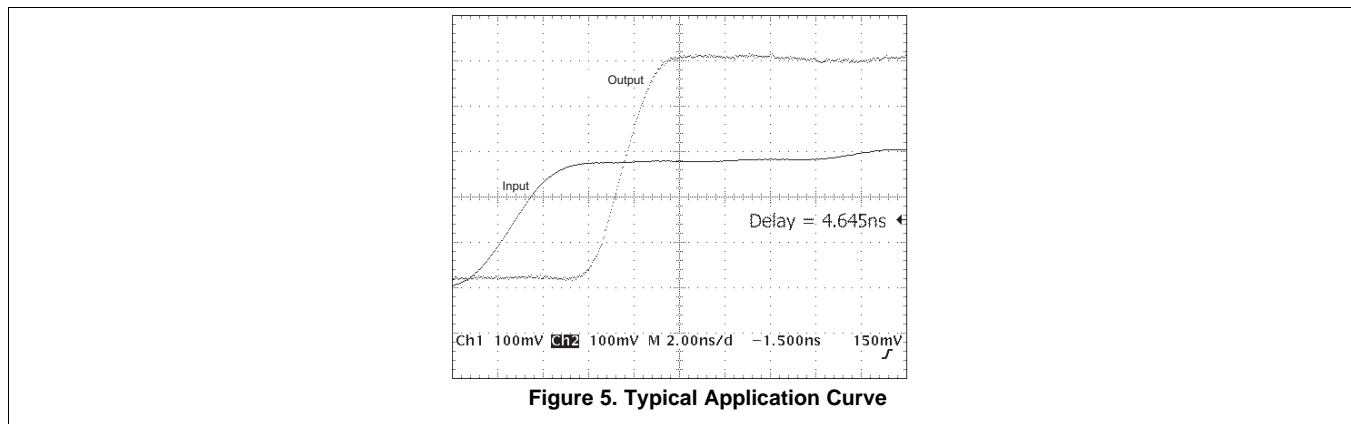

11 Power Supply Recommendations

The power supply can be any voltage between the MIN and MAX supply voltage rating located in the [Recommended Operating Conditions](#) table.

Each VCC pin should have a good bypass capacitor to prevent power disturbance. For devices with a single supply, 0.1 μf is recommended; if there are multiple VCC pins, then 0.01 μf or 0.022 μf is recommended for each power pin. It is acceptable to parallel multiple bypass caps to reject different frequencies of noise. A 0.1 μf and a 1 μf are commonly used in parallel. The bypass capacitor should be installed as close to the power pin as possible for best results.

12 Layout

12.1 Layout Guidelines

When using multiple-bit logic devices, inputs should never float.

In many cases, functions or parts of functions of digital logic devices are unused, for example, when only two inputs of a triple-input AND gate are used or only 3 of the 4 buffer gates are used. Such input pins should not be left unconnected because the undefined voltages at the outside connections result in undefined operational states. [Figure 6](#) specifies the rules that must be observed under all circumstances. All unused inputs of digital logic devices must be connected to a high or low bias to prevent them from floating. The logic level that should be applied to any particular unused input depends on the function of the device. Generally they will be tied to GND or V_{CC}, whichever makes more sense or is more convenient. It is generally acceptable to float outputs, unless the part is a transceiver. If the transceiver has an output enable pin, it will disable the output section of the part when asserted. This will not disable the input section of the I/Os, so they cannot float when disabled.

12.2 Layout Example

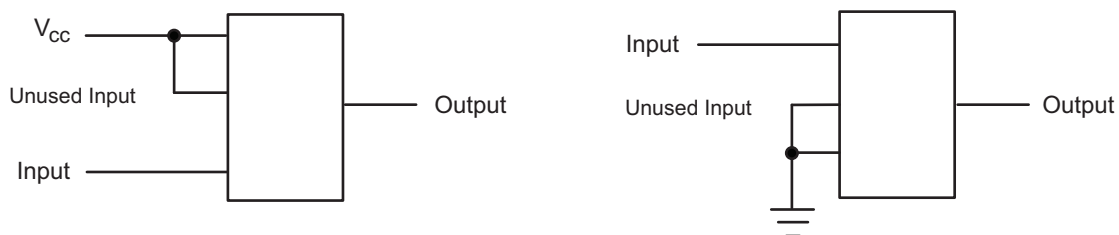

Figure 6. Layout Diagram

13 Device and Documentation Support

13.1 Related Links

The table below lists quick access links. Categories include technical documents, support and community resources, tools and software, and quick access to sample or buy.

Table 2. Related Links

| PARTS | PRODUCT FOLDER | SAMPLE & BUY | TECHNICAL DOCUMENTS | TOOLS & SOFTWARE | SUPPORT & COMMUNITY |
|-------------|----------------------------|----------------------------|----------------------------|----------------------------|----------------------------|
| SN54AHCT595 | Click here | Click here | Click here | Click here | Click here |
| SN74AHCT595 | Click here | Click here | Click here | Click here | Click here |

13.2 Trademarks

All trademarks are the property of their respective owners.

13.3 Electrostatic Discharge Caution



These devices have limited built-in ESD protection. The leads should be shorted together or the device placed in conductive foam during storage or handling to prevent electrostatic damage to the MOS gates.

13.4 Glossary

[SLYZ022](#) — *TI Glossary*.

This glossary lists and explains terms, acronyms, and definitions.

14 Mechanical, Packaging, and Orderable Information

The following pages include mechanical, packaging, and orderable information. This information is the most current data available for the designated devices. This data is subject to change without notice and revision of this document. For browser-based versions of this data sheet, refer to the left-hand navigation.

PACKAGING INFORMATION

| Orderable Device | Status (1) | Package Type | Package Drawing | Pins | Package Qty | Eco Plan (2) | Lead/Ball Finish (6) | MSL Peak Temp (3) | Op Temp (°C) | Device Marking (4/5) | Samples |
|------------------|---------------|--------------|-----------------|------|-------------|-------------------------|-------------------------|----------------------|--------------|-------------------------|-------------------------|
| SN74AHCT595D | ACTIVE | SOIC | D | 16 | 40 | Green (RoHS & no Sb/Br) | CU NIPDAU | Level-1-260C-UNLIM | -40 to 85 | AHCT595 | Samples |
| SN74AHCT595DBR | ACTIVE | SSOP | DB | 16 | 2000 | Green (RoHS & no Sb/Br) | CU NIPDAU | Level-1-260C-UNLIM | -40 to 85 | HB595 | Samples |
| SN74AHCT595DR | ACTIVE | SOIC | D | 16 | 2500 | Green (RoHS & no Sb/Br) | CU NIPDAU | Level-1-260C-UNLIM | -40 to 85 | AHCT595 | Samples |
| SN74AHCT595DRE4 | ACTIVE | SOIC | D | 16 | 2500 | Green (RoHS & no Sb/Br) | CU NIPDAU | Level-1-260C-UNLIM | -40 to 85 | AHCT595 | Samples |
| SN74AHCT595N | ACTIVE | PDIP | N | 16 | 25 | Green (RoHS & no Sb/Br) | CU NIPDAU | N / A for Pkg Type | -40 to 85 | SN74AHCT595N | Samples |
| SN74AHCT595NE4 | ACTIVE | PDIP | N | 16 | 25 | Green (RoHS & no Sb/Br) | CU NIPDAU | N / A for Pkg Type | -40 to 85 | SN74AHCT595N | Samples |
| SN74AHCT595PW | ACTIVE | TSSOP | PW | 16 | 90 | Green (RoHS & no Sb/Br) | CU NIPDAU | Level-1-260C-UNLIM | -40 to 85 | HB595 | Samples |
| SN74AHCT595PWR | ACTIVE | TSSOP | PW | 16 | 2000 | Green (RoHS & no Sb/Br) | CU NIPDAU | Level-1-260C-UNLIM | -40 to 85 | HB595 | Samples |
| SN74AHCT595PWRG3 | ACTIVE | TSSOP | PW | 16 | 2000 | Green (RoHS & no Sb/Br) | CU SN | Level-1-260C-UNLIM | -40 to 85 | HB595 | Samples |

(1) The marketing status values are defined as follows:

ACTIVE: Product device recommended for new designs.

LIFEBUY: TI has announced that the device will be discontinued, and a lifetime-buy period is in effect.

NRND: Not recommended for new designs. Device is in production to support existing customers, but TI does not recommend using this part in a new design.

PREVIEW: Device has been announced but is not in production. Samples may or may not be available.

OBSOLETE: TI has discontinued the production of the device.

(2) **RoHS:** TI defines "RoHS" to mean semiconductor products that are compliant with the current EU RoHS requirements for all 10 RoHS substances, including the requirement that RoHS substance do not exceed 0.1% by weight in homogeneous materials. Where designed to be soldered at high temperatures, "RoHS" products are suitable for use in specified lead-free processes. TI may reference these types of products as "Pb-Free".

RoHS Exempt: TI defines "RoHS Exempt" to mean products that contain lead but are compliant with EU RoHS pursuant to a specific EU RoHS exemption.

Green: TI defines "Green" to mean the content of Chlorine (Cl) and Bromine (Br) based flame retardants meet JS709B low halogen requirements of <=1000ppm threshold. Antimony trioxide based flame retardants must also meet the <=1000ppm threshold requirement.

(3) MSL, Peak Temp. - The Moisture Sensitivity Level rating according to the JEDEC industry standard classifications, and peak solder temperature.

(4) There may be additional marking, which relates to the logo, the lot trace code information, or the environmental category on the device.

(5) Multiple Device Markings will be inside parentheses. Only one Device Marking contained in parentheses and separated by a "~" will appear on a device. If a line is indented then it is a continuation of the previous line and the two combined represent the entire Device Marking for that device.

(6) Lead/Ball Finish - Orderable Devices may have multiple material finish options. Finish options are separated by a vertical ruled line. Lead/Ball Finish values may wrap to two lines if the finish value exceeds the maximum column width.

Important Information and Disclaimer:The information provided on this page represents TI's knowledge and belief as of the date that it is provided. TI bases its knowledge and belief on information provided by third parties, and makes no representation or warranty as to the accuracy of such information. Efforts are underway to better integrate information from third parties. TI has taken and continues to take reasonable steps to provide representative and accurate information but may not have conducted destructive testing or chemical analysis on incoming materials and chemicals. TI and TI suppliers consider certain information to be proprietary, and thus CAS numbers and other limited information may not be available for release.

In no event shall TI's liability arising out of such information exceed the total purchase price of the TI part(s) at issue in this document sold by TI to Customer on an annual basis.

TAPE AND REEL INFORMATION



QUADRANT ASSIGNMENTS FOR PIN 1 ORIENTATION IN TAPE



*All dimensions are nominal

| Device | Package Type | Package Drawing | Pins | SPQ | Reel Diameter (mm) | Reel Width W1 (mm) | A0 (mm) | B0 (mm) | K0 (mm) | P1 (mm) | W (mm) | Pin1 Quadrant |
|------------------|--------------|-----------------|------|------|--------------------|--------------------|---------|---------|---------|---------|--------|---------------|
| SN74AHCT595DR | SOIC | D | 16 | 2500 | 330.0 | 16.4 | 6.5 | 10.3 | 2.1 | 8.0 | 16.0 | Q1 |
| SN74AHCT595PWR | TSSOP | PW | 16 | 2000 | 330.0 | 12.4 | 6.9 | 5.6 | 1.6 | 8.0 | 12.0 | Q1 |
| SN74AHCT595PWRG3 | TSSOP | PW | 16 | 2000 | 330.0 | 12.4 | 6.9 | 5.6 | 1.6 | 8.0 | 12.0 | Q1 |

TAPE AND REEL BOX DIMENSIONS



*All dimensions are nominal

| Device | Package Type | Package Drawing | Pins | SPQ | Length (mm) | Width (mm) | Height (mm) |
|-----------------|--------------|-----------------|------|------|-------------|------------|-------------|
| SN74AHCT595DR | SOIC | D | 16 | 2500 | 333.2 | 345.9 | 28.6 |
| SN74AHCT595PWR | TSSOP | PW | 16 | 2000 | 367.0 | 367.0 | 35.0 |
| SN74AHCT595PWG3 | TSSOP | PW | 16 | 2000 | 364.0 | 364.0 | 27.0 |

D (R-PDSO-G16)

PLASTIC SMALL OUTLINE



4040047-6/M 06/11

- NOTES:
- A. All linear dimensions are in inches (millimeters).
 - B. This drawing is subject to change without notice.
 -  C. Body length does not include mold flash, protrusions, or gate burrs. Mold flash, protrusions, or gate burrs shall not exceed 0.006 (0,15) each side.
 -  D. Body width does not include interlead flash. Interlead flash shall not exceed 0.017 (0,43) each side.
 - E. Reference JEDEC MS-012 variation AC.

D (R-PDSO-G16)

PLASTIC SMALL OUTLINE



- NOTES:
- All linear dimensions are in millimeters.
 - This drawing is subject to change without notice.
 - Publication IPC-7351 is recommended for alternate designs.
 - Laser cutting apertures with trapezoidal walls and also rounding corners will offer better paste release. Customers should contact their board assembly site for stencil design recommendations. Refer to IPC-7525 for other stencil recommendations.
 - Customers should contact their board fabrication site for solder mask tolerances between and around signal pads.



4220204/A 02/2017

NOTES:

1. All linear dimensions are in millimeters. Any dimensions in parenthesis are for reference only. Dimensioning and tolerancing per ASME Y14.5M.
2. This drawing is subject to change without notice.
3. This dimension does not include mold flash, protrusions, or gate burrs. Mold flash, protrusions, or gate burrs shall not exceed 0.15 mm per side.
4. This dimension does not include interlead flash. Interlead flash shall not exceed 0.25 mm per side.
5. Reference JEDEC registration MO-153.

EXAMPLE BOARD LAYOUT

PW0016A

TSSOP - 1.2 mm max height

SMALL OUTLINE PACKAGE



LAND PATTERN EXAMPLE
EXPOSED METAL SHOWN
SCALE: 10X



SOLDER MASK DETAILS

4220204/A 02/2017

NOTES: (continued)

- 6. Publication IPC-7351 may have alternate designs.
- 7. Solder mask tolerances between and around signal pads can vary based on board fabrication site.

EXAMPLE STENCIL DESIGN

PW0016A

TSSOP - 1.2 mm max height

SMALL OUTLINE PACKAGE



SOLDER PASTE EXAMPLE
BASED ON 0.125 mm THICK STENCIL
SCALE: 10X

4220204/A 02/2017

NOTES: (continued)

8. Laser cutting apertures with trapezoidal walls and rounded corners may offer better paste release. IPC-7525 may have alternate design recommendations.
9. Board assembly site may have different recommendations for stencil design.

DB (R-PDSO-G**)

PLASTIC SMALL-OUTLINE

28 PINS SHOWN



- NOTES: A. All linear dimensions are in millimeters.
 B. This drawing is subject to change without notice.
 C. Body dimensions do not include mold flash or protrusion not to exceed 0,15.
 D. Falls within JEDEC MO-150

N (R-PDIP-T**)

PLASTIC DUAL-IN-LINE PACKAGE

16 PINS SHOWN



- NOTES:
- A. All linear dimensions are in inches (millimeters).
 - B. This drawing is subject to change without notice.
 - $\triangle C$ Falls within JEDEC MS-001, except 18 and 20 pin minimum body length (Dim A).
 - $\triangle D$ The 20 pin end lead shoulder width is a vendor option, either half or full width.

IMPORTANT NOTICE AND DISCLAIMER

TI PROVIDES TECHNICAL AND RELIABILITY DATA (INCLUDING DATASHEETS), DESIGN RESOURCES (INCLUDING REFERENCE DESIGNS), APPLICATION OR OTHER DESIGN ADVICE, WEB TOOLS, SAFETY INFORMATION, AND OTHER RESOURCES "AS IS" AND WITH ALL FAULTS, AND DISCLAIMS ALL WARRANTIES, EXPRESS AND IMPLIED, INCLUDING WITHOUT LIMITATION ANY IMPLIED WARRANTIES OF MERCHANTABILITY, FITNESS FOR A PARTICULAR PURPOSE OR NON-INFRINGEMENT OF THIRD PARTY INTELLECTUAL PROPERTY RIGHTS.

These resources are intended for skilled developers designing with TI products. You are solely responsible for (1) selecting the appropriate TI products for your application, (2) designing, validating and testing your application, and (3) ensuring your application meets applicable standards, and any other safety, security, or other requirements. These resources are subject to change without notice. TI grants you permission to use these resources only for development of an application that uses the TI products described in the resource. Other reproduction and display of these resources is prohibited. No license is granted to any other TI intellectual property right or to any third party intellectual property right. TI disclaims responsibility for, and you will fully indemnify TI and its representatives against, any claims, damages, costs, losses, and liabilities arising out of your use of these resources.

TI's products are provided subject to TI's Terms of Sale (www.ti.com/legal/termsofsale.html) or other applicable terms available either on ti.com or provided in conjunction with such TI products. TI's provision of these resources does not expand or otherwise alter TI's applicable warranties or warranty disclaimers for TI products.

Mailing Address: Texas Instruments, Post Office Box 655303, Dallas, Texas 75265
Copyright © 2019, Texas Instruments Incorporated

Looking for pricing, stock, or lifecycle information?

Click below to explore more details on WIN SOURCE:

 [View SN74AHCT595PWR on WIN SOURCE](#)

 [Texas Instruments](#) Information

Optimize Your Supply Chain with WIN SOURCE Solutions

-  Global Sourcing Solution
-  Obsolete Management
-  Cost Control Management
-  Shortage Management
-  Alternative Solution
-  Excess Inventory Management