



**THE DATASHEET OF
SN74ACT8990FNR**



- **Members of the Texas Instruments SCOPE™ Family of Testability Products**
- **Compatible With the IEEE Standard 1149.1-1990 (JTAG) Test Access Port and Boundary-Scan Architecture**
- **Control Operation of Up to Six Parallel Target Scan Paths**
- **Accommodate Pipeline Delay to Target of Up to 31 Clock Cycles**
- **Scan Data Up to 2³² Clock Cycles**
- **Execute Instructions for Up to 2³² Clock Cycles**
- **Each Device Includes Four Bidirectional Event Pins for Additional Test Capability**
- **Inputs Are TTL-Voltage Compatible**
- **EPIC™ (Enhanced-Performance Implanted CMOS) 1-μm Process**
- **Packaged in 44-Pin Plastic Leaded Chip Carrier (FN), 68-Pin Ceramic Pin Grid Array (GB), and 68-Pin Ceramic Quad Flat Packages (HV)**

description

The 'ACT8990 test-bus controllers (TBC) are members of the Texas Instruments SCOPE™ testability integrated-circuit family. This family of components supports IEEE Standard 1149.1-1990 (JTAG) boundary scan to facilitate testing of complex circuit-board assemblies. The 'ACT8990 differ from other SCOPE™ integrated circuits. Their function is to control the JTAG serial-test bus rather than being target boundary-scannable devices.

The required signals of the JTAG serial-test bus – test clock (TCK), test mode select (TMS), test data input (TDI), and test data output (TDO) can be connected from the TBC to a target device without additional logic. This is done as a chain of IEEE Standard 1149.1-1990 boundary-scannable components that share the same serial-test bus. The TBC generates TMS and TDI signals for its target(s), receives TDO signals from its target(s), and buffers its test clock input (TCKI) to a test clock output (TCKO) for distribution to its target(s). The TMS, TDI, and TDO signals can be connected to a target directly or via a pipeline, with a retiming delay of up to 31 bits. Since the TBC can be configured to generate up to six separate TMS signals [TMS (5–0)], it can be used to control up to six target scan paths that are connected in parallel (i.e., sharing common TCK, TDI, and TDO signals).

While most operations of the TBC are synchronous to TCKI, a test-off ($\overline{\text{TOFF}}$) input is provided for output control of the target interface, and a test-reset ($\overline{\text{TRST}}$) input is provided for hardware/software reset of the TBC. In addition, four event [EVENT (3–0)] I/Os are provided for asynchronous communication to target device(s). Each event has its own event generation/detection logic, and detected events can be counted by two 16-bit counters.

The TBC operates under the control of a host microprocessor/microcontroller via the 5-bit address bus [ADRS (4–0)] and the 16-bit read/write data bus [DATA (15–0)]. Read ($\overline{\text{RD}}$) and write ($\overline{\text{WR}}$) strobes are implemented such that the critical host-interface timing is independent of the TCKI period. Any one of 24 registers can be addressed for read and/or write operations. In addition to control and status registers, the TBC contains two command registers, a read buffer, and a write buffer. Status of the TBC is transmitted to the host via ready ($\overline{\text{RDY}}$) and interrupt ($\overline{\text{INT}}$) outputs.

Major commands can be issued by the host to cause the TBC to generate the TMS sequences necessary to move the target(s) from any stable test-access-port (TAP) controller state to any other stable TAP state, to execute instructions in the Run-Test/Idle TAP state, or to scan instruction or test data through the target(s). A 32-bit counter can be preset to allow a predetermined number of execution or scan operations.

Serial data that appears at the selected TDI input (TDI1 or TDI0) is transferred into the read buffer, which can be read by the host to obtain up to 16 bits of the serial-data stream. Serial data that is transmitted from the TDO output is written by the host to the write buffer.



Please be aware that an important notice concerning availability, standard warranty, and use in critical applications of Texas Instruments semiconductor products and disclaimers thereto appears at the end of this data sheet.

SCOPE and EPIC are trademarks of Texas Instruments Incorporated.

PRODUCTION DATA information is current as of publication date. Products conform to specifications per the terms of Texas Instruments standard warranty. Production processing does not necessarily include testing of all parameters.

 **TEXAS
INSTRUMENTS**

POST OFFICE BOX 655303 • DALLAS, TEXAS 75265

Copyright © 1997, Texas Instruments Incorporated
On products compliant to MIL-PRF-38535, all parameters are tested unless otherwise noted. On all other products, production processing does not necessarily include testing of all parameters.

SN54ACT8990, SN74ACT8990
TEST-BUS CONTROLLERS
IEEE STD 1149.1 (JTAG) TAP MASTERS WITH 16-BIT GENERIC HOST INTERFACES
 SCAS190E – JUNE 1990 – REVISED JANUARY 1997

description (continued)

The SN54ACT8990 is characterized for operation over the full military temperature range of -55°C to 125°C .
 The SN74ACT8990 is characterized for operation from 0°C to 70°C .

SN54ACT8990 . . . HV PACKAGE
(TOP VIEW)

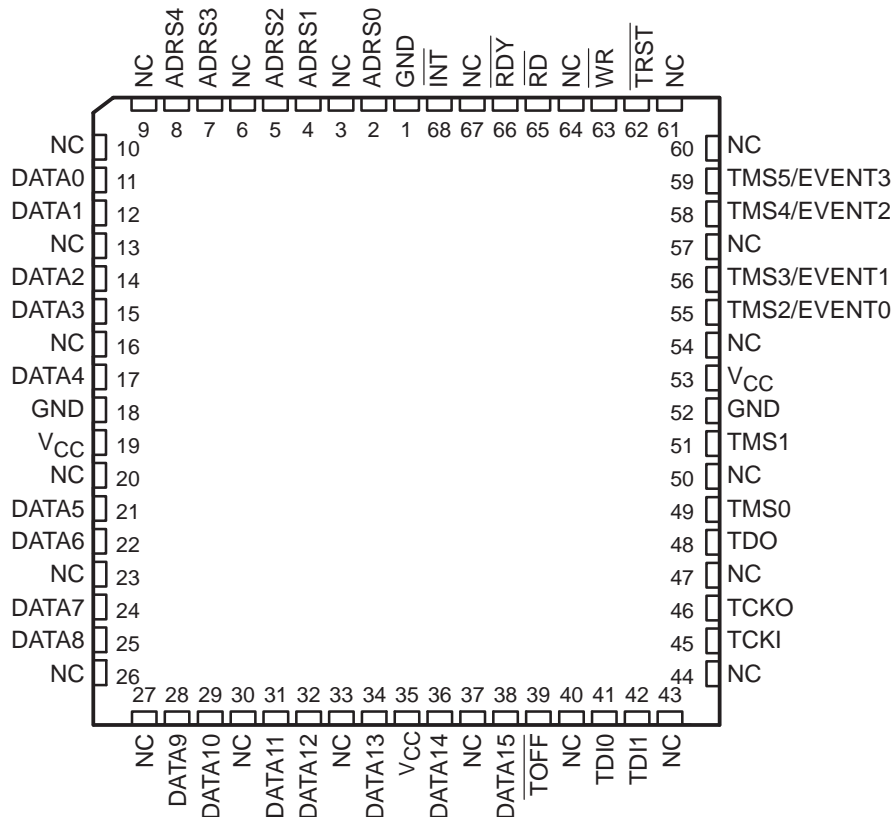

NC – No internal connection



SN74ACT8990 . . . FN PACKAGE
(TOP VIEW)

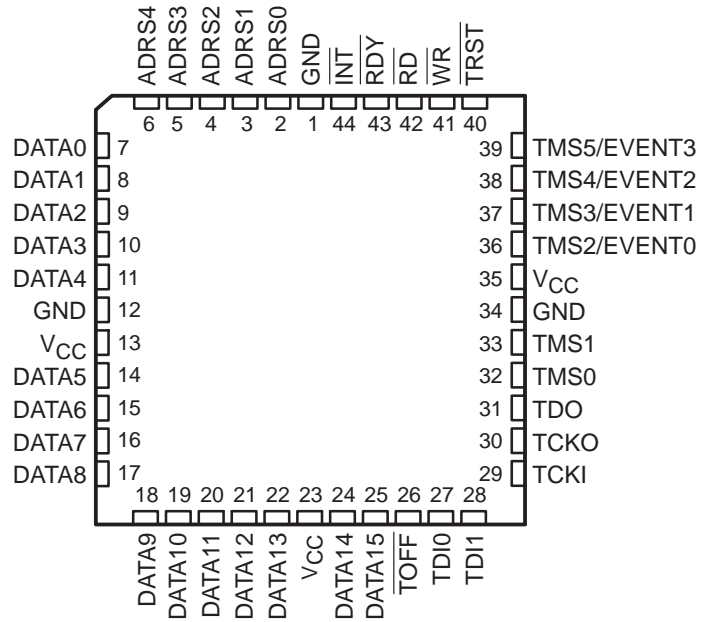

SN54ACT8990 . . . GB PACKAGE
(TOP VIEW)

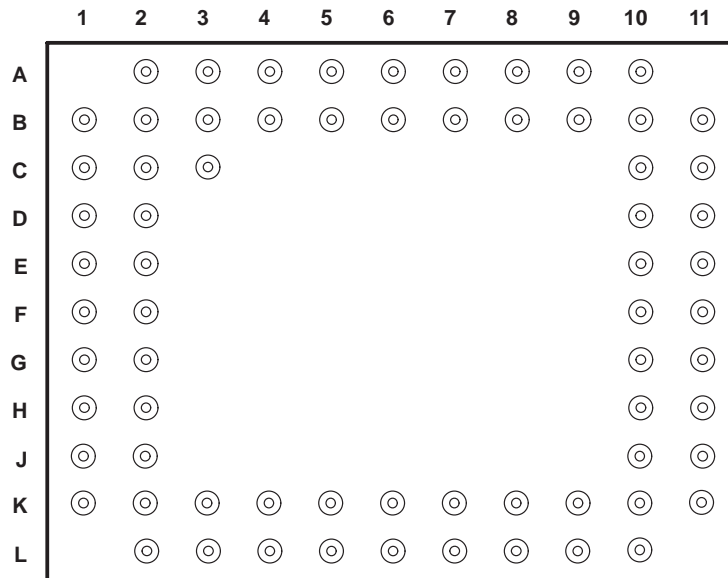

SN54ACT8990, SN74ACT8990
TEST-BUS CONTROLLERS
IEEE STD 1149.1 (JTAG) TAP MASTERS WITH 16-BIT GENERIC HOST INTERFACES
 SCAS190E – JUNE 1990 – REVISED JANUARY 1997

Table 1. Terminal Assignments

TERMINAL		TERMINAL		TERMINAL		TERMINAL	
NO.	NAME	NO.	NAME	NO.	NAME	NO.	NAME
A2	NC	B10	NC	F11	NC	K6	NC
A3	ADRS4	B11	NC	G1	DATA5	K7	V _{CC}
A4	NC	C1	DATA2	G2	NC	K8	DATA15
A5	ADRS1	C2	DATA1	G10	NC	K9	TDI0
A6	ADRS0	C3	NC	G11	TMS1	K10	NC
A7	NC	C10	TMS4/EVENT2	H1	NC	K11	TCKI
A8	$\overline{\text{INT}}$	C11	TMS5/EVENT3	H2	DATA6	L2	DATA9
A9	$\overline{\text{RD}}$	D1	DATA4	H10	TDO	L3	NC
A10	$\overline{\text{TRST}}$	D2	DATA3	H11	TMS0	L4	DATA12
B1	DATA0	D10	TMS3/EVENT1	J1	DATA8	L5	DATA13
B2	NC	D11	NC	J2	DATA7	L6	NC
B3	ADRS3	E1	NC	J10	TCKO	L7	DATA14
B4	ADRS2	E2	GND	J11	NC	L8	$\overline{\text{TOFF}}$
B5	NC	E10	V _{CC}	K1	NC	L9	TDI1
B6	NC	E11	TMS2/EVENT0	K2	NC	L10	NC
B7	GND	F1	V _{CC}	K3	DATA10		
B8	$\overline{\text{RDY}}$	F2	NC	K4	DATA11		
B9	$\overline{\text{WR}}$	F10	GND	K5	NC		

NC – No internal connection

functional block diagram

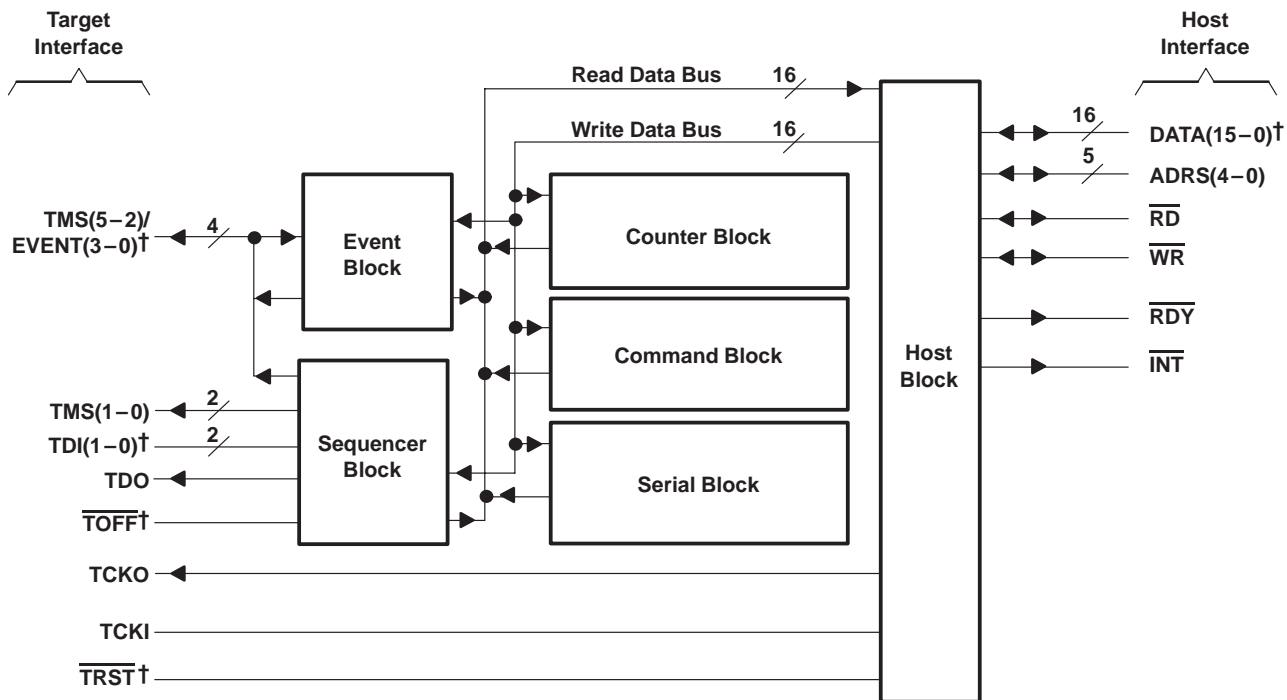

† Inputs have internal pullup resistors.



Terminal Functions

TERMINAL NAME	I/O	DESCRIPTION
ADRS4–ADRS0	I	Address inputs. ADRS4–ADRS0 form the 5-bit address bus that interfaces the TBC to its host. These inputs specify the TBC register to be read from or written to.
DATA15–DATA0	I/O	Data inputs and outputs. DATA15–DATA0 form the 16-bit bidirectional data bus that interfaces the TBC to its host. Data is read from or written to the TBC register using this data bus.
GND		Ground
$\overline{\text{INT}}$	O	Interrupt. $\overline{\text{INT}}$ transmits an interrupt signal to the host. When the TBC requires service from the host, $\overline{\text{INT}}$ is asserted (low). $\overline{\text{INT}}$ will remain asserted (low) until the host has completed the required service.
NC		No connection
$\overline{\text{RD}}$	I	Read strobe. $\overline{\text{RD}}$ is the active low output enable for the data bus. $\overline{\text{RD}}$ is used as the strobe for reading data from the selected TBC register.
$\overline{\text{RDY}}$	O	Ready. $\overline{\text{RDY}}$ transmits a status signal to the host. When the TBC is ready to accept a read or write operation from the host, $\overline{\text{RDY}}$ is asserted (low). $\overline{\text{RDY}}$ is not asserted (high) when the TBC is in recovery from a read, write, command, or reset operation.
TCKI	I	Test clock input. TCKI is the clock input for the TBC. Most operations of the TBC are synchronous to TCKI. When enabled, all target interface outputs change on the falling edge of TCKI. Sampling of target interface inputs are configured to occur on either the rising edge or falling edge of TCKI.
TCKO	O	Test clock output. TCKO distributes TCK to the target(s). The TCKO is configured to be disabled, constant zero, constant one, or to follow TCKI. When TCKO follows TCKI, it is delayed to match the delay of generating the TDO and TMS signals.
TDI1–TDI0	I	Test data inputs. The TDI1–TDI0 serial inputs are used for shifting test data from the target(s). The TDI inputs can be directly connected to the TDO pin(s) of the target(s).
TDO	O	Test data output. TDO is used for shifting test data into the target(s). TDO can be directly connected to the TDI terminal(s) of the target(s).
TMS1–TMS0	O	Test mode select outputs. These parallel outputs transmit TMS signals to the target(s), which direct them through their TAP controller states. TMS1–TMS0 can be directly connected to the TMS terminals of the target(s).
TMS5–TMS2/ EVENT3–EVENT0	I/O	Test mode select outputs or event inputs/outputs. These I/Os can be configured for use as either TMS outputs or event inputs/outputs. As TMS outputs, they function similarly to TMS1–TMS0 above. As event I/Os, they can be used to receive/transmit interrupt signals to/from the target(s).
$\overline{\text{TOFF}}$	I	Test-off input. $\overline{\text{TOFF}}$ is the active low output disable for all outputs and I/Os of the target interface (TCKO, TDO, TMS, TMS/EVENT).
$\overline{\text{TRST}}$	I	Test-reset input. $\overline{\text{TRST}}$ is used to initiate hardware and software reset operations of the TBC. Hardware reset begins when $\overline{\text{TRST}}$ is asserted (low). Software reset begins when $\overline{\text{TRST}}$ is released (high) and proceeds synchronously to TCKI to completion in a predetermined number of cycles.
$\overline{\text{WR}}$	I	Write input. $\overline{\text{WR}}$ is the strobe for writing data to a TBC data register. Signals present at the data and address buses are captured on the rising edge of $\overline{\text{WR}}$.
V _{CC}		Supply voltage

absolute maximum ratings over operating free-air temperature range (unless otherwise noted)†

Supply voltage range, V_{CC}	-0.5 V to 7 V
Input voltage range, V_I (see Note 1)	-0.5 V to V_{CC}
Output voltage range, V_O (see Note 1)	-0.5 V to V_{CC}
Input clamp current, I_{IK} ($V_I < 0$ or $V_I > V_{CC}$)	± 20 mA
Output clamp current, I_{OK} ($V_O < 0$ or $V_O > V_{CC}$)	± 20 mA
Continuous output current, I_O ($V_O = 0$ to V_{CC})	± 25 mA
Maximum power dissipation at $T_A = 55^\circ\text{C}$ (in still air) (see Note 2): FN package	1.5W
Storage temperature range, T_{stg}	-65°C to 150°C

† Stresses beyond those listed under “absolute maximum ratings” may cause permanent damage to the device. These are stress ratings only, and functional operation of the device at these or any other conditions beyond those indicated under “recommended operating conditions” is not implied. Exposure to absolute-maximum-rated conditions for extended periods may affect device reliability.

- NOTES: 1. The input and output voltage ratings may be exceeded if the input and output clamp-current ratings are observed.
 2. The maximum package power dissipation is calculated using a junction temperature of 150°C and a board trace length of 75 mils. For more information, refer to the *Package Thermal Considerations* application note in the *ABT Advanced BiCMOS Technology Data Book*, literature number SCBD002.

recommended operating conditions

	SN54ACT8990		SN74ACT8990		UNIT
	MIN	MAX	MIN	MAX	
V_{CC} Supply voltage	4.5	5.5	4.5	5.5	V
V_{IH} High-level input voltage	2		2		V
V_{IL} Low-level input voltage		0.8		0.8	V
V_I Input voltage	0	V_{CC}	0	V_{CC}	V
V_O Output voltage	0	V_{CC}	0	V_{CC}	V
I_{OH} High-level output current		-8		-8	mA
I_{OL} Low-level output current		8		8	mA
T_A Operating free-air temperature	-55	125	0	70	$^\circ\text{C}$



electrical characteristics over recommended operating free-air temperature range (unless otherwise noted)

PARAMETER	TEST CONDITIONS		T _A = 25°C			SN54ACT8990		SN74ACT8990		UNIT
			MIN	TYP†	MAX	MIN	MAX	MIN	MAX	
V _{OH}	V _{CC} = 4.5 V	I _{OH} = -20 μA	4.4			4.4		4.4		V
		I _{OH} = -8 mA	3.7			3.7		3.7		
	V _{CC} = 5.5 V	I _{OH} = -20 μA	5.4			5.4		5.4		
		I _{OH} = -8 mA	4.7			4.7		4.7		
V _{OL}	V _{CC} = 4.5 V to 5.5 V	I _{OL} = 20 μA				0.1		0.1		V
		I _{OL} = 8 mA				0.5		0.5		
I _I	ADRS, $\overline{\text{RD}}$, WR, TCKI	V _{CC} = 5.5 V, V _I = V _{CC} or GND				±1		±1		μA
	TDI, $\overline{\text{TOFF}}$, TRST	V _{CC} = 5.5 V	V _I = V _{CC}			±1		±1		
I _{OZ} ‡	INT, RDY, TCKO, TDO, TMS	V _{CC} = 5.5 V, V _O = V _{CC} or GND				±10		±10		μA
	DATA, TMS/EVENT	V _{CC} = 5.5 V	V _O = V _{CC}			±10		±10		
		V _{CC} = 5.5 V	V _O = GND			-35	-70	-250	-35	
I _{CC}	V _{CC} = 5.5 V, I _O = 0, V _I = V _{CC} or GND		450*			450		450		μA
	V _{CC} = 5.5 V, C _L = 50 pF f _{clock} = 30 MHz		100							mA
C _i	V _I = V _{CC} or GND		5*							pF
C _{io}	V _I = V _{CC} or GND		9*							pF
C _o	V _I = V _{CC} or GND		8*							pF

* On products compliant to MIL-PRF-38535, this parameter does not apply.

† Typical values are at V_{CC} = 5 V.

‡ For I/O ports, the parameter I_{OZ} includes the input leakage.

timing requirements over recommended ranges of supply voltage and operating free-air temperature (see Figure 1)

		SN54ACT8990		SN74ACT8990		UNIT
		MIN	MAX	MIN	MAX	
f_{clock}	Clock frequency	0	30	0	30	MHz
t_w	Pulse duration	$\overline{\text{RD}}$ low†		5.5		ns
		$\overline{\text{WR}}$ low	5.5		5.5	ns
		EVENT high or low	8		8	
		TCKI high or low	10.5		10.5	
		$\overline{\text{TRST}}$ low	6		6	
t_{su}	Setup time	ADRS† before $\overline{\text{RD}}\uparrow$		6.5		ns
		ADRS before $\overline{\text{WR}}\uparrow$	6.5		6.5	ns
		DATA before $\overline{\text{WR}}\uparrow$	6		6	
		EVENT before TCKI↑	6		5.5	
		EVENT before TCKI↓	5		5	
		TDI before TCKI↑	2		2	
		TDI before TCKI↓	2		2	
t_h	Hold time	ADRS† after $\overline{\text{RD}}\uparrow$		5		ns
		ADRS after $\overline{\text{WR}}\uparrow$	5.5		5	ns
		DATA after $\overline{\text{WR}}\uparrow$	5.5		5.5	
		EVENT after TCKI↑	5.5		5	
		EVENT after TCKI↓	5		5	
		TDI after TCKI↑	4		2.5	
		TDI after TCKI↓	4		2.5	

† Applies only in the case where ADRS (4-0) = 10110 (read buffer).

IEEE STD 1149.1 (JTAG) TAP MASTERS WITH 16-BIT GENERIC HOST INTERFACES

SCAS190E – JUNE 1990 – REVISED JANUARY 1997

switching characteristics over recommended ranges of supply voltage and operating free-air temperature (see Figure 1)

PARAMETER	FROM (INPUT)	TO (OUTPUT)	SN54ACT8990		SN74ACT8990		UNIT
			MIN	MAX	MIN	MAX	
f_{max}			30		30		MHz
t_{PLH}	ADRS	DATA	8	43	19.5	39.3	ns
t_{PHL}			8	43	19.5	39.3	
t_{PLH}	$\overline{RD}\uparrow$	\overline{RDY}	5.3	17	5.3	13.8	ns
	$\overline{WR}\uparrow$		2.5	16	2.5	13	
t_{PLH}	TCKI \uparrow	\overline{INT}	3.7	16	3.7	12.9	ns
t_{PHL}			5.5	15	5.5	13.1	
t_{PHL}	TCKI \uparrow	\overline{RDY}	4.4	15	4.4	13.4	ns
t_{PLH}	TCKI \uparrow	TCKO	3.3	17	3.3	14.1	ns
t_{PLH}	TCKI \downarrow	TCKO	2.3	19	2.3	15.9	ns
			t_{PHL}	3.6	17	3.6	
t_{PLH}	TCKI \downarrow	TDO	2.9	19	2.9	17.5	ns
			t_{PHL}	5.2	20	5.2	
t_{PLH}	TCKI \downarrow	TMS	3.1	19	3.1	17.5	ns
			t_{PHL}	5.1	19	5.1	
t_{PLH}	TCKI \downarrow	TMS/EVENT	1.5	19	1.5	17.5	ns
			t_{PHL}	3.5	20	3.5	
t_{PZH}	$\overline{RD}\downarrow$	DATA	3.8	21	3.8	17.6	ns
			t_{PZL}	6.8	28	6.8	
t_{PZH}	TCKI \uparrow	\overline{INT}	4.9	19	4.9	15.3	ns
		\overline{RDY}	3.6	19	3.6	15.3	
t_{PZH}	TCKI \downarrow	TCKO	4.1	23	4.1	19.2	ns
			t_{PZL}	4.8	20	4.8	
t_{PZH}	TCKI \downarrow	TDO	4.3	22	4.3	19.5	ns
			t_{PZL}	5	20	5	
t_{PZH}	TCKI \downarrow	TMS	4.6	23	4.6	19.9	ns
			t_{PZL}	5.1	20	5.1	
t_{PZH}	TCKI \downarrow	TMS/EVENT	2	21	2	18.8	ns
			t_{PZL}	3.2	20	3.2	
t_{PZH}	$\overline{TOFF}\uparrow$	TCKO	4.6	16	4.6	12.2	ns
			t_{PZL}	3.1	14	3.1	
t_{PZH}	$\overline{TOFF}\uparrow$	TDO	4.4	15	4.4	12.2	ns
			t_{PZL}	3.5	14	3.5	
t_{PZH}	$\overline{TOFF}\uparrow$	TMS	3.1	16.2	3.1	14.7	ns
			t_{PZL}	1.9	16.7	1.9	

switching characteristics over recommended ranges of supply voltage and operating free-air temperature (continued) (see Figure 1)

PARAMETER	FROM (INPUT)	TO (OUTPUT)	SN54ACT8990		SN74ACT8990		UNIT
			MIN	MAX	MIN	MAX	
t _{PZH}	$\overline{\text{TOFF}}\uparrow$	TMS/EVENT	2.3	15.3	2.3	13.8	ns
t _{PLZ}			2.7	16.4	2.7	13.9	
t _{PHZ}	$\overline{\text{RD}}\uparrow$	DATA	3.8	18.4	3.8	15.4	ns
t _{PLZ}			4.1	17.1	4.1	14.8	
t _{PHZ}	TCKI \downarrow	TCKO	6.7	20.4	6.7	19.8	ns
t _{PLZ}			4.8	21.1	4.8	20.4	
t _{PHZ}	TCKI \downarrow	TDO	5.1	21.7	5.1	21.3	ns
t _{PLZ}			5	20.7	5	20.3	
t _{PHZ}	TCKI \downarrow	TMS	6.9	22.4	6.9	21.9	ns
t _{PLZ}			4.6	20.6	4.6	20.1	
t _{PHZ}	TCKI \downarrow	TMS/EVENT	4.7	22.5	4.7	22.1	ns
t _{PLZ}			2.8	20.5	2.8	20.1	
t _{PHZ}	$\overline{\text{TOFF}}\downarrow$	TCKO	5	15.6	5	15.4	ns
t _{PLZ}			4.4	15.5	4.4	15.3	
t _{PHZ}	$\overline{\text{TOFF}}\downarrow$	TDO	5.6	16.6	5.6	16.5	ns
t _{PLZ}			4.6	15.4	4.6	15.4	
t _{PHZ}	$\overline{\text{TOFF}}\downarrow$	TMS	4.8	19.1	4.8	17.1	ns
t _{PLZ}			4.4	17	4.4	15.8	
t _{PHZ}	$\overline{\text{TOFF}}\downarrow$	TMS/EVENT	4.5	18.8	4.5	17.3	ns
t _{PLZ}			2.4	17.1	2.4	16.2	
t _{PHZ}	$\overline{\text{TRST}}\downarrow$	DATA	5.7	23	5.7	20.8	ns
t _{PLZ}			4.2	20.3	4.2	20	
t _{PHZ}	$\overline{\text{TRST}}\downarrow$	$\overline{\text{INT}}$	6	19.6	8	19.5	ns
t _{PLZ}			6.1	18	6.1	17.8	
t _{PHZ}	$\overline{\text{TRST}}\downarrow$	$\overline{\text{RDY}}$	6.5	18.8	6.5	18.7	ns
t _{PLZ}			4.8	17.8	4.8	17.8	
t _{PHZ}	$\overline{\text{TRST}}\downarrow$	TMS/EVENT	6	21.1	6	21.1	ns
t _{PLZ}			4.2	20	4.2	19.9	

PARAMETER MEASUREMENT INFORMATION

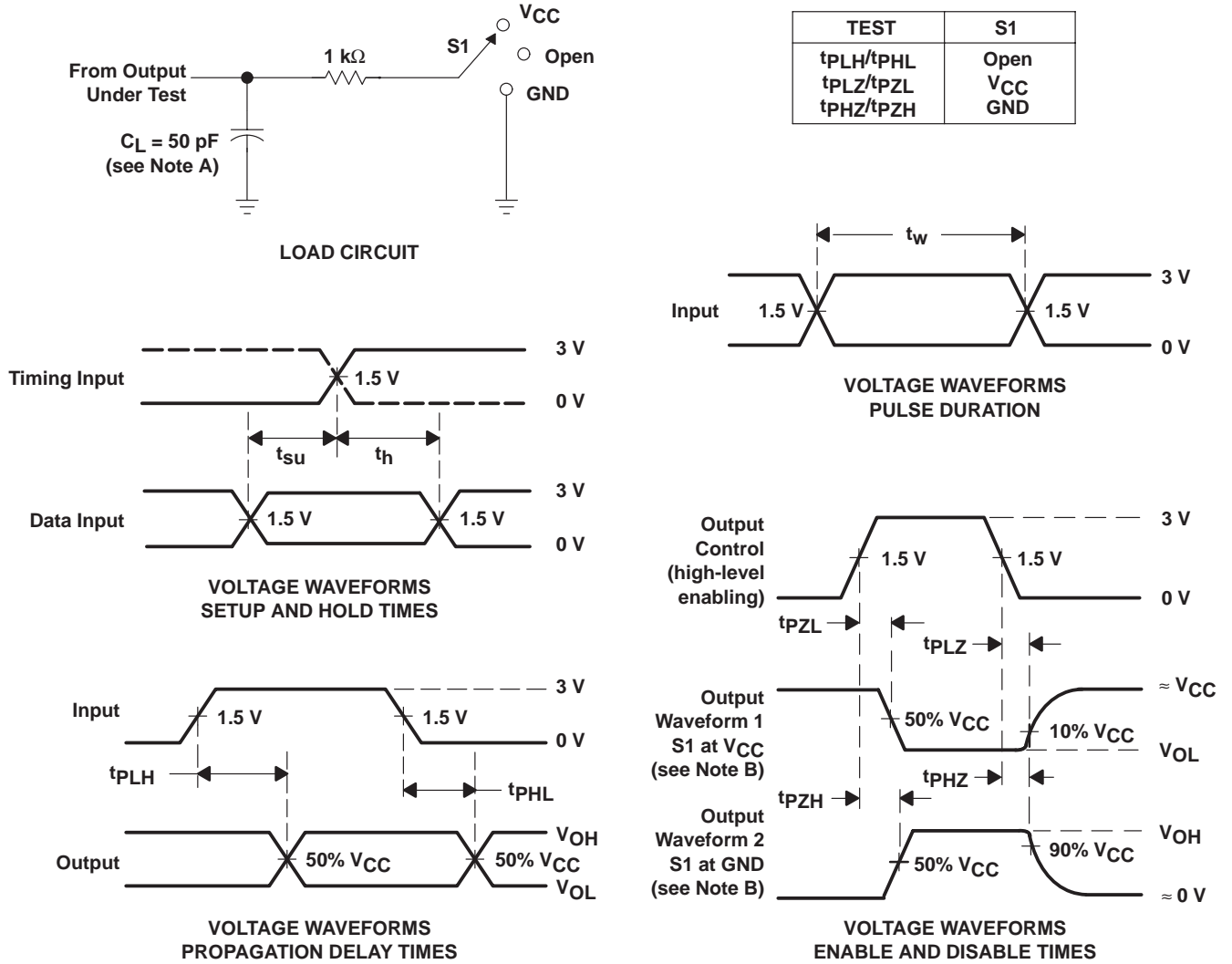

- NOTES: A. C_L includes probe and jig capacitance.
 B. Waveform 1 is for an output with internal conditions such that the output is low except when disabled by the output control. Waveform 2 is for an output with internal conditions such that the output is high except when disabled by the output control.
 C. All input pulses are supplied by generators having the following characteristics: PRR ≤ 10 MHz, Z_O = 50 Ω, t_r ≤ 3 ns, t_f ≤ 3 ns. For testing pulse duration: t_r = t_f = 1 to 3 ns. Pulse polarity can be either high-to-low-to-high or low-to-high-to-low.
 D. The outputs are measured one at a time with one transition per measurement.

Figure 1. Load Circuit and Voltage Waveforms

PACKAGING INFORMATION

Orderable Device	Status (1)	Package Type	Package Drawing	Pins	Package Qty	Eco Plan (2)	Lead/Ball Finish (6)	MSL Peak Temp (3)	Op Temp (°C)	Device Marking (4/5)	Samples
5962-9322801MXA	ACTIVE	CFP	HV	68	1	TBD	Call TI	N / A for Pkg Type	-55 to 125	5962-9322801MX A SNJ54ACT8990HV	Samples
5962-9322801MYA	ACTIVE	CPGA	GB	68	1	TBD	POST-PLATE	N / A for Pkg Type	-55 to 125	5962-9322801MY A SNJ54ACT8990GB	Samples
SN74ACT8990FN	ACTIVE	PLCC	FN	44	26	Green (RoHS & no Sb/Br)	CU NIPDAU	Level-3-260C-168 HR	-40 to 85	ACT8990	Samples
SN74ACT8990FNR	ACTIVE	PLCC	FN	44	500	Green (RoHS & no Sb/Br)	CU NIPDAU	Level-3-260C-168 HR	-40 to 85	ACT8990	Samples
SNJ54ACT8990GB	ACTIVE	CPGA	GB	68	1	TBD	POST-PLATE	N / A for Pkg Type	-55 to 125	5962-9322801MY A SNJ54ACT8990GB	Samples
SNJ54ACT8990HV	ACTIVE	CFP	HV	68	1	TBD	Call TI	N / A for Pkg Type	-55 to 125	5962-9322801MX A SNJ54ACT8990HV	Samples

(1) The marketing status values are defined as follows:

ACTIVE: Product device recommended for new designs.

LIFEBUY: TI has announced that the device will be discontinued, and a lifetime-buy period is in effect.

NRND: Not recommended for new designs. Device is in production to support existing customers, but TI does not recommend using this part in a new design.

PREVIEW: Device has been announced but is not in production. Samples may or may not be available.

OBSELETE: TI has discontinued the production of the device.

(2) Eco Plan - The planned eco-friendly classification: Pb-Free (RoHS), Pb-Free (RoHS Exempt), or Green (RoHS & no Sb/Br) - please check <http://www.ti.com/productcontent> for the latest availability information and additional product content details.

TBD: The Pb-Free/Green conversion plan has not been defined.

Pb-Free (RoHS): TI's terms "Lead-Free" or "Pb-Free" mean semiconductor products that are compatible with the current RoHS requirements for all 6 substances, including the requirement that lead not exceed 0.1% by weight in homogeneous materials. Where designed to be soldered at high temperatures, TI Pb-Free products are suitable for use in specified lead-free processes.

Pb-Free (RoHS Exempt): This component has a RoHS exemption for either 1) lead-based flip-chip solder bumps used between the die and package, or 2) lead-based die adhesive used between the die and leadframe. The component is otherwise considered Pb-Free (RoHS compatible) as defined above.

Green (RoHS & no Sb/Br): TI defines "Green" to mean Pb-Free (RoHS compatible), and free of Bromine (Br) and Antimony (Sb) based flame retardants (Br or Sb do not exceed 0.1% by weight in homogeneous material)

(3) MSL, Peak Temp. - The Moisture Sensitivity Level rating according to the JEDEC industry standard classifications, and peak solder temperature.

(4) There may be additional marking, which relates to the logo, the lot trace code information, or the environmental category on the device.

⁽⁵⁾ Multiple Device Markings will be inside parentheses. Only one Device Marking contained in parentheses and separated by a "~" will appear on a device. If a line is indented then it is a continuation of the previous line and the two combined represent the entire Device Marking for that device.

⁽⁶⁾ Lead/Ball Finish - Orderable Devices may have multiple material finish options. Finish options are separated by a vertical ruled line. Lead/Ball Finish values may wrap to two lines if the finish value exceeds the maximum column width.

Important Information and Disclaimer:The information provided on this page represents TI's knowledge and belief as of the date that it is provided. TI bases its knowledge and belief on information provided by third parties, and makes no representation or warranty as to the accuracy of such information. Efforts are underway to better integrate information from third parties. TI has taken and continues to take reasonable steps to provide representative and accurate information but may not have conducted destructive testing or chemical analysis on incoming materials and chemicals. TI and TI suppliers consider certain information to be proprietary, and thus CAS numbers and other limited information may not be available for release.

In no event shall TI's liability arising out of such information exceed the total purchase price of the TI part(s) at issue in this document sold by TI to Customer on an annual basis.

OTHER QUALIFIED VERSIONS OF SN54ACT8990, SN74ACT8990 :

- Catalog: [SN74ACT8990](#)
- Military: [SN54ACT8990](#)

NOTE: Qualified Version Definitions:

- Catalog - TI's standard catalog product
- Military - QML certified for Military and Defense Applications

HV (S-QQFP-F68)

CERAMIC QUAD FLATPACK

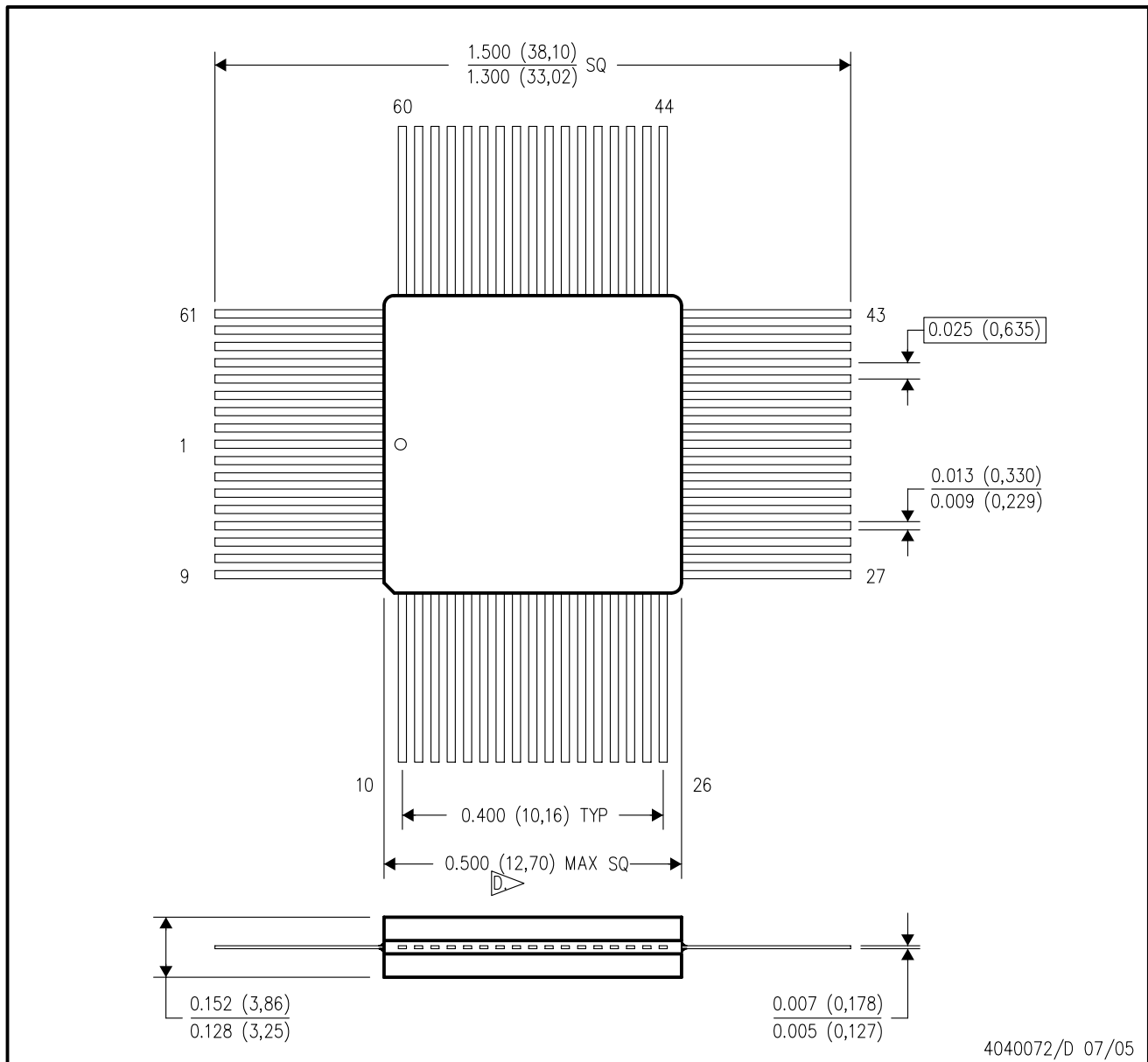

- NOTES:
- A. All linear dimensions are in inches (millimeters).
 - B. This drawing is subject to change without notice.
 - C. This package can be hermetically sealed with a ceramic lid using glass frit.
 - D. This dimension allows for package edge anomalies caused by material protrusion, such as rough ceramic, misaligned ceramic layers and lids, meniscus, and glass overrun.

GB (S-CPGA-P68)

CERAMIC PIN GRID ARRAY

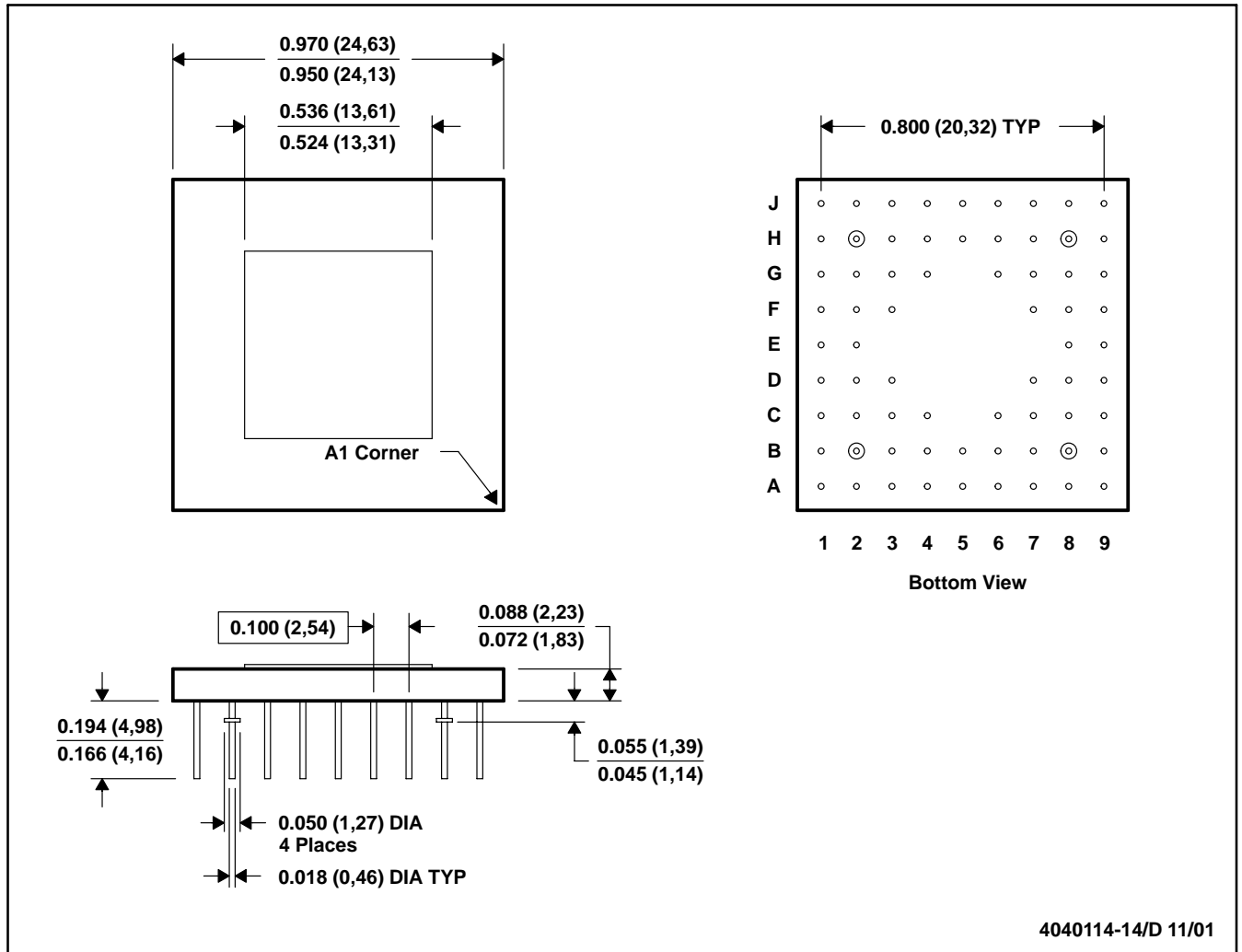

- NOTES: A. All linear dimensions are in inches (millimeters).
 B. This drawing is subject to change without notice.
 C. Index mark may appear on top or bottom depending vendor.
 D. Pins are located within 0.010 (0,25) diameter of true position relative to each other at maximum material condition and within 0.030 (0,76) diameter relative to the edges of the ceramic.
 E. This package can be hermetically sealed with metal lids or with ceramic lids using glass frit.
 F. The pins can be gold plated or solder dipped.
 G. Falls within MIL STD 1835 CMGA1-PN, CMGA13-PN and JEDEC MO-067 AA, MO-066 AA respectively

GENERIC PACKAGE VIEW

FN 44

PLCC - 4.57 mm max height

PLASTIC CHIP CARRIER

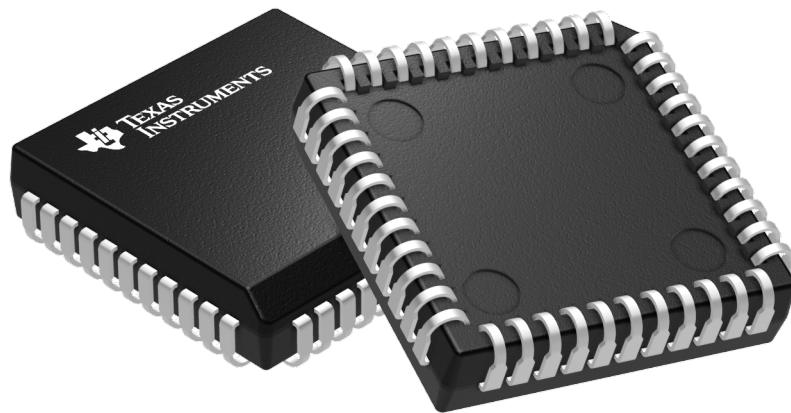

Images above are just a representation of the package family, actual package may vary.
Refer to the product data sheet for package details.

4040005-4/C



PACKAGE OUTLINE

FN0044A

PLCC - 4.57 mm max height

PLASTIC CHIP CARRIER

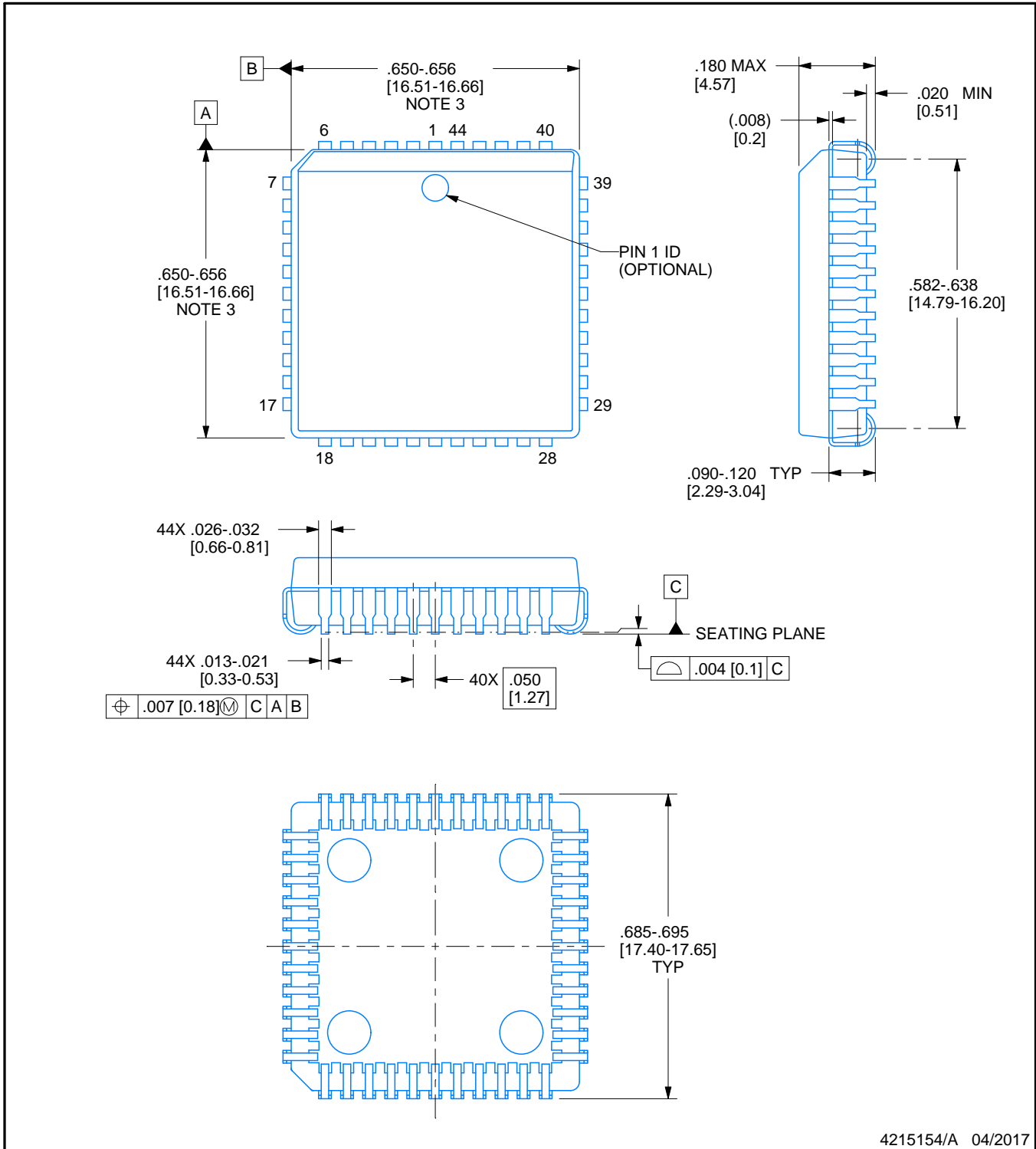

4215154/A 04/2017

NOTES:

1. All linear dimensions are in inches. Any dimensions in brackets are in millimeters. Any dimensions in parenthesis are for reference only. Controlling dimensions are in inches. Dimensioning and tolerancing per ASME Y14.5M.
2. This drawing is subject to change without notice.
3. Dimension does not include mold protrusion. Maximum allowable mold protrusion .01 in [0.25 mm] per side.
4. Reference JEDEC registration MS-018.

EXAMPLE BOARD LAYOUT

FN0044A

PLCC - 4.57 mm max height

PLASTIC CHIP CARRIER

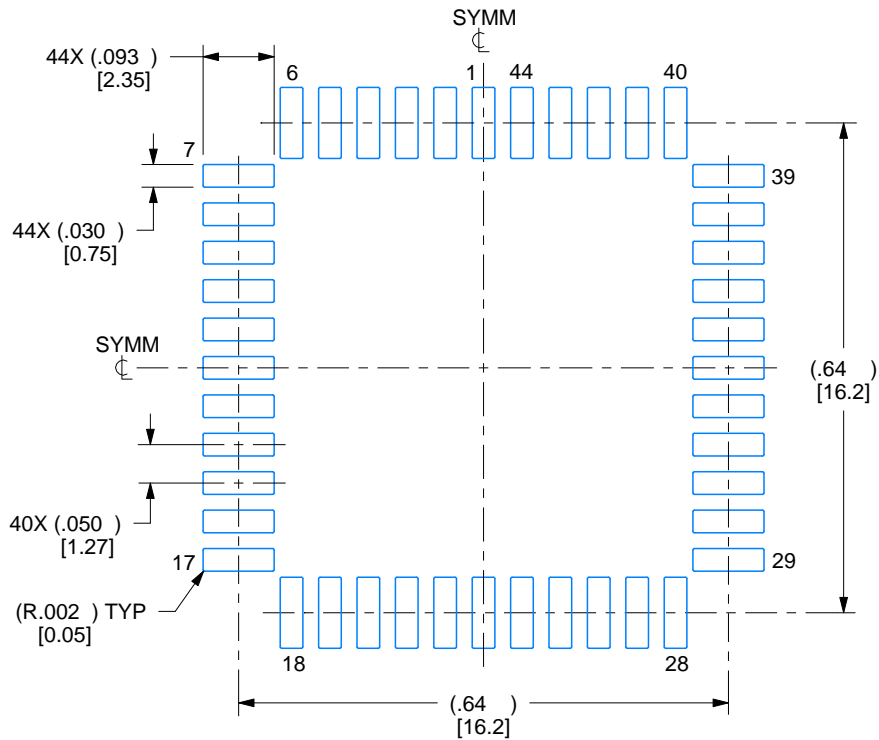

LAND PATTERN EXAMPLE
EXPOSED METAL SHOWN
SCALE:4X

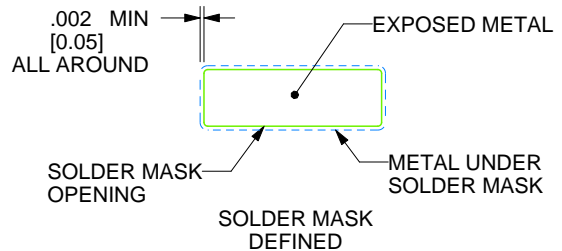
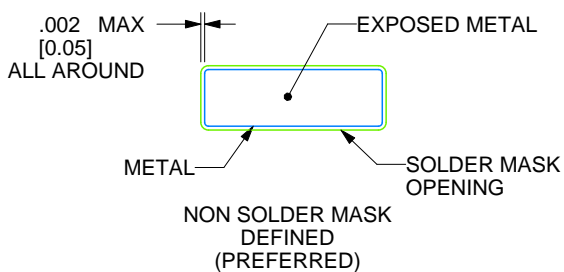

SOLDER MASK DETAILS

4215154/A 04/2017

NOTES: (continued)

- 5. Publication IPC-7351 may have alternate designs.
- 6. Solder mask tolerances between and around signal pads can vary based on board fabrication site.

EXAMPLE STENCIL DESIGN

FN0044A

PLCC - 4.57 mm max height

PLASTIC CHIP CARRIER

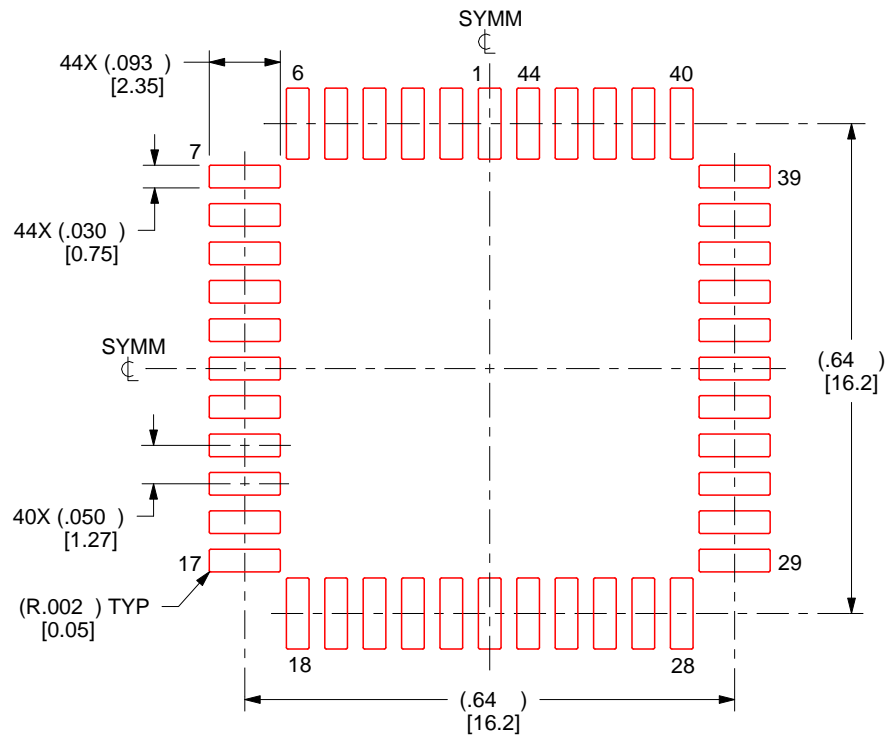

SOLDER PASTE EXAMPLE
BASED ON 0.125 mm THICK STENCIL
SCALE:4X

4215154/A 04/2017

NOTES: (continued)

7. Laser cutting apertures with trapezoidal walls and rounded corners may offer better paste release. IPC-7525 may have alternate design recommendations.
8. Board assembly site may have different recommendations for stencil design.

IMPORTANT NOTICE

Texas Instruments Incorporated (TI) reserves the right to make corrections, enhancements, improvements and other changes to its semiconductor products and services per JESD46, latest issue, and to discontinue any product or service per JESD48, latest issue. Buyers should obtain the latest relevant information before placing orders and should verify that such information is current and complete.

TI's published terms of sale for semiconductor products (<http://www.ti.com/sc/docs/stdterms.htm>) apply to the sale of packaged integrated circuit products that TI has qualified and released to market. Additional terms may apply to the use or sale of other types of TI products and services.

Reproduction of significant portions of TI information in TI data sheets is permissible only if reproduction is without alteration and is accompanied by all associated warranties, conditions, limitations, and notices. TI is not responsible or liable for such reproduced documentation. Information of third parties may be subject to additional restrictions. Resale of TI products or services with statements different from or beyond the parameters stated by TI for that product or service voids all express and any implied warranties for the associated TI product or service and is an unfair and deceptive business practice. TI is not responsible or liable for any such statements.

Buyers and others who are developing systems that incorporate TI products (collectively, "Designers") understand and agree that Designers remain responsible for using their independent analysis, evaluation and judgment in designing their applications and that Designers have full and exclusive responsibility to assure the safety of Designers' applications and compliance of their applications (and of all TI products used in or for Designers' applications) with all applicable regulations, laws and other applicable requirements. Designer represents that, with respect to their applications, Designer has all the necessary expertise to create and implement safeguards that (1) anticipate dangerous consequences of failures, (2) monitor failures and their consequences, and (3) lessen the likelihood of failures that might cause harm and take appropriate actions. Designer agrees that prior to using or distributing any applications that include TI products, Designer will thoroughly test such applications and the functionality of such TI products as used in such applications.

TI's provision of technical, application or other design advice, quality characterization, reliability data or other services or information, including, but not limited to, reference designs and materials relating to evaluation modules, (collectively, "TI Resources") are intended to assist designers who are developing applications that incorporate TI products; by downloading, accessing or using TI Resources in any way, Designer (individually or, if Designer is acting on behalf of a company, Designer's company) agrees to use any particular TI Resource solely for this purpose and subject to the terms of this Notice.

TI's provision of TI Resources does not expand or otherwise alter TI's applicable published warranties or warranty disclaimers for TI products, and no additional obligations or liabilities arise from TI providing such TI Resources. TI reserves the right to make corrections, enhancements, improvements and other changes to its TI Resources. TI has not conducted any testing other than that specifically described in the published documentation for a particular TI Resource.

Designer is authorized to use, copy and modify any individual TI Resource only in connection with the development of applications that include the TI product(s) identified in such TI Resource. NO OTHER LICENSE, EXPRESS OR IMPLIED, BY ESTOPPEL OR OTHERWISE TO ANY OTHER TI INTELLECTUAL PROPERTY RIGHT, AND NO LICENSE TO ANY TECHNOLOGY OR INTELLECTUAL PROPERTY RIGHT OF TI OR ANY THIRD PARTY IS GRANTED HEREIN, including but not limited to any patent right, copyright, mask work right, or other intellectual property right relating to any combination, machine, or process in which TI products or services are used. Information regarding or referencing third-party products or services does not constitute a license to use such products or services, or a warranty or endorsement thereof. Use of TI Resources may require a license from a third party under the patents or other intellectual property of the third party, or a license from TI under the patents or other intellectual property of TI.

TI RESOURCES ARE PROVIDED "AS IS" AND WITH ALL FAULTS. TI DISCLAIMS ALL OTHER WARRANTIES OR REPRESENTATIONS, EXPRESS OR IMPLIED, REGARDING RESOURCES OR USE THEREOF, INCLUDING BUT NOT LIMITED TO ACCURACY OR COMPLETENESS, TITLE, ANY EPIDEMIC FAILURE WARRANTY AND ANY IMPLIED WARRANTIES OF MERCHANTABILITY, FITNESS FOR A PARTICULAR PURPOSE, AND NON-INFRINGEMENT OF ANY THIRD PARTY INTELLECTUAL PROPERTY RIGHTS. TI SHALL NOT BE LIABLE FOR AND SHALL NOT DEFEND OR INDEMNIFY DESIGNER AGAINST ANY CLAIM, INCLUDING BUT NOT LIMITED TO ANY INFRINGEMENT CLAIM THAT RELATES TO OR IS BASED ON ANY COMBINATION OF PRODUCTS EVEN IF DESCRIBED IN TI RESOURCES OR OTHERWISE. IN NO EVENT SHALL TI BE LIABLE FOR ANY ACTUAL, DIRECT, SPECIAL, COLLATERAL, INDIRECT, PUNITIVE, INCIDENTAL, CONSEQUENTIAL OR EXEMPLARY DAMAGES IN CONNECTION WITH OR ARISING OUT OF TI RESOURCES OR USE THEREOF, AND REGARDLESS OF WHETHER TI HAS BEEN ADVISED OF THE POSSIBILITY OF SUCH DAMAGES.

Unless TI has explicitly designated an individual product as meeting the requirements of a particular industry standard (e.g., ISO/TS 16949 and ISO 26262), TI is not responsible for any failure to meet such industry standard requirements.

Where TI specifically promotes products as facilitating functional safety or as compliant with industry functional safety standards, such products are intended to help enable customers to design and create their own applications that meet applicable functional safety standards and requirements. Using products in an application does not by itself establish any safety features in the application. Designers must ensure compliance with safety-related requirements and standards applicable to their applications. Designer may not use any TI products in life-critical medical equipment unless authorized officers of the parties have executed a special contract specifically governing such use. Life-critical medical equipment is medical equipment where failure of such equipment would cause serious bodily injury or death (e.g., life support, pacemakers, defibrillators, heart pumps, neurostimulators, and implantables). Such equipment includes, without limitation, all medical devices identified by the U.S. Food and Drug Administration as Class III devices and equivalent classifications outside the U.S.

TI may expressly designate certain products as completing a particular qualification (e.g., Q100, Military Grade, or Enhanced Product). Designers agree that it has the necessary expertise to select the product with the appropriate qualification designation for their applications and that proper product selection is at Designers' own risk. Designers are solely responsible for compliance with all legal and regulatory requirements in connection with such selection.

Designer will fully indemnify TI and its representatives against any damages, costs, losses, and/or liabilities arising out of Designer's non-compliance with the terms and provisions of this Notice.

Looking for pricing, stock, or lifecycle information?

Click below to explore more details on WIN SOURCE:

- ⊖ [View SN74ACT8990FNR on WIN SOURCE](#)
- ⊖ [Texas Instruments](#) Information

Optimize Your Supply Chain with WIN SOURCE Solutions

- ✓ Global Sourcing Solution
- ✓ Obsolete Management
- ✓ Cost Control Management
- ✓ Shortage Management
- ✓ Alternative Solution
- ✓ Excess Inventory Management