

SN54ABTH25245, SN74ABTH25245 25-Ω OCTAL BUS TRANSCEIVERS WITH 3-STATE OUTPUTS

SCBS251F – JUNE 1992 – REVISED MAY 1997

- State-of-the-Art *EPIC-IIB™* BiCMOS Design Significantly Reduces Power Dissipation
- ESD Protection Exceeds 2000 V Per MIL-STD-883, Method 3015; Exceeds 200 V Using Machine Model (C = 200 pF, R = 0)
- Latch-Up Performance Exceeds 500 mA Per JEDEC Standard JESD-17
- Typical V_{OLP} (Output Ground Bounce) < 1 V at $V_{CC} = 5$ V, $T_A = 25^\circ\text{C}$
- High-Impedance State During Power Up and Power Down
- Designed to Facilitate Incident-Wave Switching for Line Impedances of 25 Ω or Greater
- Distributed V_{CC} and GND Pin Configuration Minimizes High-Speed Switching Noise
- Bus Hold on Data Inputs Eliminates the Need for External Pullup/Pulldown Resistors
- Package Options Include Plastic Small-Outline (DW) Package, Ceramic Chip Carriers (FK), and Standard Plastic (NT) and Ceramic (JT) DIPs

description

The 'ABTH25245 are 25-Ω octal bus transceivers designed for asynchronous communication between data buses. They improve both the performance and density of 3-state memory address drivers, clock drivers, and bus-oriented transceivers.

These devices allow noninverted data transmission from the A bus to the B bus or from the B bus to the A bus, depending on the logic level at the direction-control (DIR) input. The output-enable (\overline{OE}) input can disable the device so that both buses are effectively isolated. When \overline{OE} is low, the device is active.

These transceivers are capable of sinking 188 mA of I_{OL} current, which facilitates switching 25-Ω transmission lines on the incident wave. The distributed V_{CC} and GND pins minimize switching noise for more-reliable system operation.

Active bus-hold circuitry is provided to hold unused or floating data inputs at a valid logic level.

SN54ABTH25245 . . . JT PACKAGE
SN74ABTH25245 . . . DW OR NT PACKAGE
(TOP VIEW)

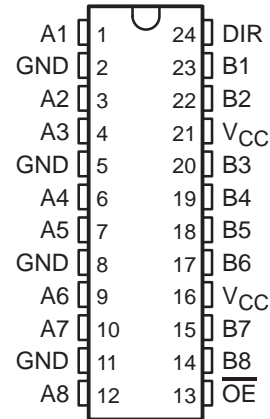

SN54ABTH25245 . . . FK PACKAGE
(TOP VIEW)

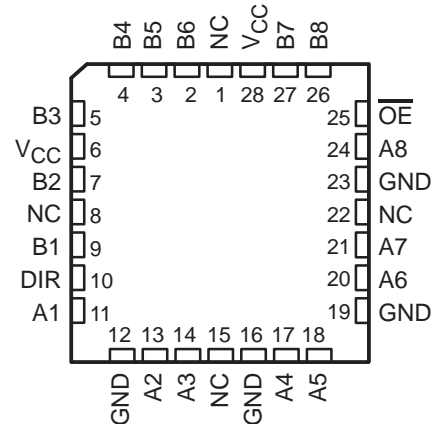

NC – No internal connection



Please be aware that an important notice concerning availability, standard warranty, and use in critical applications of Texas Instruments semiconductor products and disclaimers thereto appears at the end of this data sheet.

EPIC-IIB is a trademark of Texas Instruments Incorporated.

UNLESS OTHERWISE NOTED this document contains PRODUCTION DATA information current as of publication date. Products conform to specifications per the terms of Texas Instruments standard warranty. Production processing does not necessarily include testing of all parameters.

**TEXAS
INSTRUMENTS**

POST OFFICE BOX 655303 • DALLAS, TEXAS 75265

Copyright © 1997, Texas Instruments Incorporated

SN54ABTH25245, SN74ABTH25245 25-Ω OCTAL BUS TRANSCEIVERS WITH 3-STATE OUTPUTS

SCBS251F – JUNE 1992 – REVISED MAY 1997

description (continued)

When V_{CC} is between 0 and 2.1 V, the device is in the high-impedance state during power up or power down. However, to ensure the high-impedance state above 2.1 V, \overline{OE} should be tied to V_{CC} through a pullup resistor; the minimum value of the resistor is determined by the current-sinking capability of the driver.

The SN54ABTH25245 is characterized for operation over the full military temperature range of -55°C to 125°C . The SN74ABTH25245 is characterized for operation from -40°C to 85°C .

FUNCTION TABLE

INPUTS		OPERATION
\overline{OE}	DIR	
L	L	B data to A bus
L	H	A data to B bus
H	X	Isolation

logic symbol†

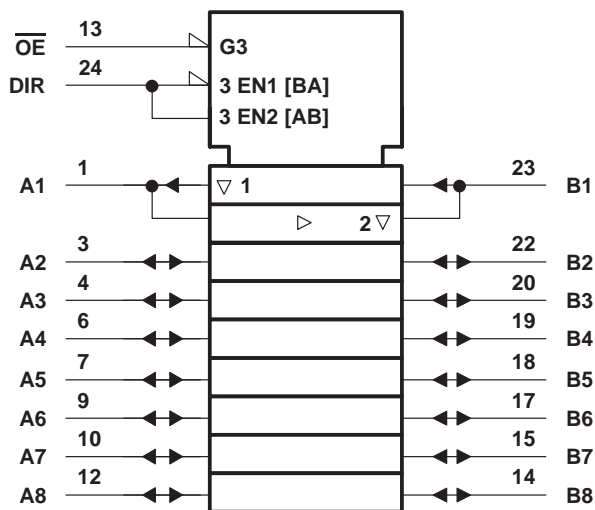

† This symbol is in accordance with ANSI/IEEE Std 91-1984 and IEC Publication 617-12. Pin numbers shown are for the DW, JT, and NT packages.

SN54ABTH25245, SN74ABTH25245
 25-Ω OCTAL BUS TRANSCEIVERS
 WITH 3-STATE OUTPUTS

SCBS251F – JUNE 1992 – REVISED MAY 1997

logic diagram (positive logic)

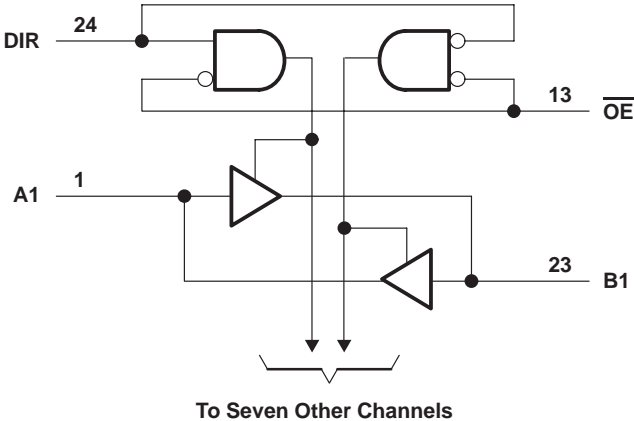

Pin numbers shown are for the DW, JT, and NT packages.

absolute maximum ratings over operating free-air temperature range (unless otherwise noted)†

Supply voltage range, V_{CC}	-0.5 V to 7 V
Input voltage range, V_I (except I/O ports) (see Note 1)	-0.5 V to 7 V
Voltage range applied to any output in the disabled or power-off state, V_O	-0.5 V to 5.5 V
Voltage range applied to any output in the high state, V_O	-0.5 V to V_{CC}
Input clamp current, I_{IK} ($V_I < 0$)	-18 mA
Output clamp current, I_{OK} ($V_O < 0$)	-50 mA
Current into any output in the low state, I_O : SN74ABTH25245 (A port)	376 mA
SN74ABTH25245 (B port)	128 mA
Package thermal impedance, θ_{JA} (see Note 2): DW package	81°C/W
NT package	67°C/W
Storage temperature range, T_{stg}	-65°C to 150°C

† Stresses beyond those listed under “absolute maximum ratings” may cause permanent damage to the device. These are stress ratings only, and functional operation of the device at these or any other conditions beyond those indicated under “recommended operating conditions” is not implied. Exposure to absolute-maximum-rated conditions for extended periods may affect device reliability.

NOTES: 1. The input and output negative-voltage ratings may be exceeded if the input and output clamp-current ratings are observed.
 2. The package thermal impedance is calculated in accordance with EIA/JEDEC Std JESD51, except for through-hole packages, which use a trace length of zero.



SN54ABTH25245, SN74ABTH25245
25-Ω OCTAL BUS TRANSCEIVERS
WITH 3-STATE OUTPUTS

SCBS251F – JUNE 1992 – REVISED MAY 1997

recommended operating conditions (see Note 3)

			SN54ABTH25245		SN74ABTH25245		UNIT
			MIN	MAX	MIN	MAX	
V_{CC}	Supply voltage		4.5	5.5	4.5	5.5	V
V_{IH}	High-level input voltage		2		2		V
V_{IL}	Low-level input voltage			0.8		0.8	V
V_I	Input voltage		0	V_{CC}	0	V_{CC}	V
I_{IK}	Input clamp current			-18		-18	mA
I_{OH}	High-level output current	A port		-80		-80	mA
		B port		-32		-32	
I_{OL}	Low-level output current	A port		188		188	mA
		B port		64		64	
$\Delta t/\Delta v$	Input transition rise or fall rate	Outputs enabled	Control inputs		4		ns/V
			A or B ports		10		
$\Delta t/\Delta V_{CC}$	Power-up ramp rate		200		200		$\mu s/V$
T_A	Operating free-air temperature		-55	125	-40	85	$^{\circ}C$

NOTE 3: Unused control pins must be held high or low to prevent them from floating.

SN54ABTH25245, SN74ABTH25245
25-Ω OCTAL BUS TRANSCEIVERS
WITH 3-STATE OUTPUTS

SCBS251F – JUNE 1992 – REVISED MAY 1997

electrical characteristics over recommended operating free-air temperature range (unless otherwise noted)

PARAMETER		TEST CONDITIONS	SN54ABTH25245		SN74ABTH25245		UNIT
			MIN	TYP†	MAX	MIN	
V _{IK}		V _{CC} = 4.5 V, I _I = -18 mA			-1.2		V
V _{OH}	A port	V _{CC} = 4.75 V, I _{OH} = -3 mA	2.7		2.7		V
		V _{CC} = 4.5 V, I _{OH} = -80 mA	2.4		2.4		
	B port	V _{CC} = 4.5 V, I _{OH} = -3 mA	2.5		2.5		
		V _{CC} = 5 V, I _{OH} = -3 mA	3		3		
		V _{CC} = 4.5 V, I _{OH} = -32 mA	2*		2		
V _{OL}	A port	V _{CC} = 4.5 V	I _{OL} = 94 mA		0.55		V
			I _{OL} = 188 mA		0.7		
	B port	V _{CC} = 4.5 V, I _{OL} = 64 mA	0.55*		0.55		
V _{hys}			100		100		mV
I _I	Control inputs	V _{CC} = 0 to 5.5 V, V _I = V _{CC} or GND			±1		μA
	A or B ports	V _{CC} = 2.1 V to 5.5 V, V _I = V _{CC} or GND			±20		
I _I (hold)	A or B ports	V _{CC} = 4.5 V	V _I = 0.8 V		100		μA
			V _I = 2 V		-100		
I _{OZPU} ‡		V _{CC} = 0 to 2.1 V, V _O = 0.5 V to 2.7 V, \overline{OE} = X			±50		μA
I _{OZPD} ‡		V _{CC} = 2.1 V to 0, V _O = 0.5 V to 2.7 V, \overline{OE} = X			±50		μA
I _{off}		V _{CC} = 0, V _I or V _O ≤ 4.5 V			±100		μA
I _{CEX}		V _{CC} = 5.5 V, V _O = 5.5 V			50		μA
I _O §	B port	V _{CC} = 5.5 V, V _O = 2.5 V	-50	-210	-50	-210	mA
I _{CC}		V _{CC} = 5.5 V, Outputs open, V _I = V _{CC} or GND	Outputs high		500		μA
			Outputs low		20		mA
			Outputs disabled		500		μA
ΔI _{CC} ¶		V _{CC} = 5.5 V, One input at 3.4 V, Other inputs at V _{CC} or GND			1		mA
C _i	Control inputs	V _{CC} = 5 V, V _I = V _{CC} or GND			4		pF
C _{io}	A or B ports	V _{CC} = 5 V, V _O = V _{CC} or GND			11.5		pF

* On products compliant to MIL-PRF-38535, this parameter does not apply.

† All typical values are at V_{CC} = 5 V, T_A = 25°C.

‡ This parameter is characterized, but not production tested.

§ Not more than one output should be tested at a time, and the duration of the test should not exceed one second.

¶ This is the increase in supply current for each input that is at the specified TTL voltage level rather than V_{CC} or GND.

PRODUCT PREVIEW information concerns products in the formative or design phase of development. Characteristic data and other specifications are design goals. Texas Instruments reserves the right to change or discontinue these products without notice.



POST OFFICE BOX 655303 • DALLAS, TEXAS 75265

SN54ABTH25245, SN74ABTH25245
25-Ω OCTAL BUS TRANSCEIVERS
WITH 3-STATE OUTPUTS

SCBS251F – JUNE 1992 – REVISED MAY 1997

switching characteristics over recommended ranges of supply voltage and operating free-air temperature, $C_L = 50$ pF (unless otherwise noted) (see Figure 1)

PARAMETER	FROM (INPUT)	TO (OUTPUT)	$V_{CC} = 5$ V, $T_A = 25^\circ$ C			SN54ABTH25245		SN74ABTH25245		UNIT
			MIN	TYP	MAX	MIN	MAX	MIN	MAX	
t_{PLH}	A or B	B or A	1	2.3	3.5	1		1	3.9	ns
t_{PHL}			1	2.4	3.5	1		1	4.3	
t_{PZH}	\overline{OE}	A or B	1.5	3.7	5.4	1.5		1.5	6.5	ns
t_{PZL}			1.4	4	5.8	1.4		1.4	6.8	
t_{PHZ}	\overline{OE}	A or B	2	4.3	6.1	2		2	7.2	ns
t_{PLZ}			2	3.9	5.8	2		2	6.4	

PRODUCT PREVIEW information concerns products in the formative or design phase of development. Characteristic data and other specifications are design goals. Texas Instruments reserves the right to change or discontinue these products without notice.



POST OFFICE BOX 655303 • DALLAS, TEXAS 75265

PARAMETER MEASUREMENT INFORMATION

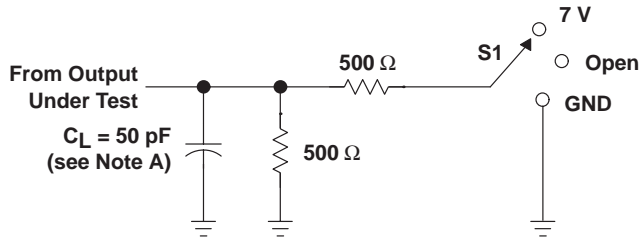

TEST	S1
t_{PLH}/t_{PHL}	Open
t_{PLZ}/t_{PZL}	7 V
t_{PHZ}/t_{PZH}	Open

LOAD CIRCUIT

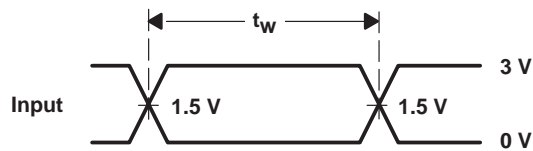

VOLTAGE WAVEFORMS
PULSE DURATION

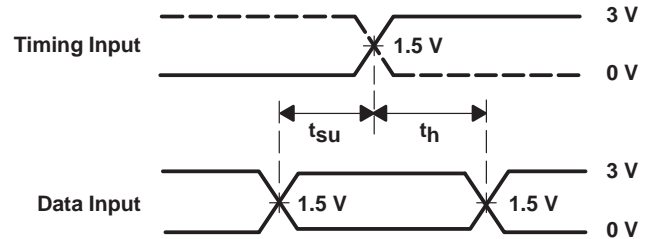

VOLTAGE WAVEFORMS
SETUP AND HOLD TIMES

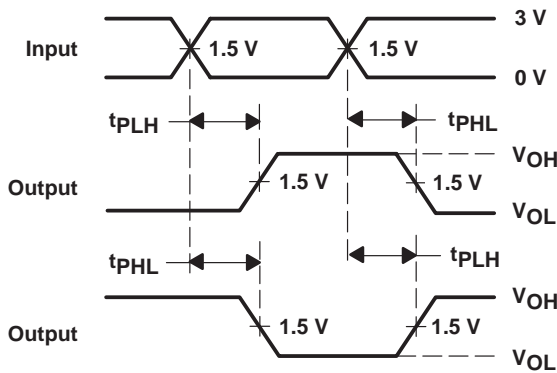

VOLTAGE WAVEFORMS
PROPAGATION DELAY TIMES
INVERTING AND NONINVERTING OUTPUTS

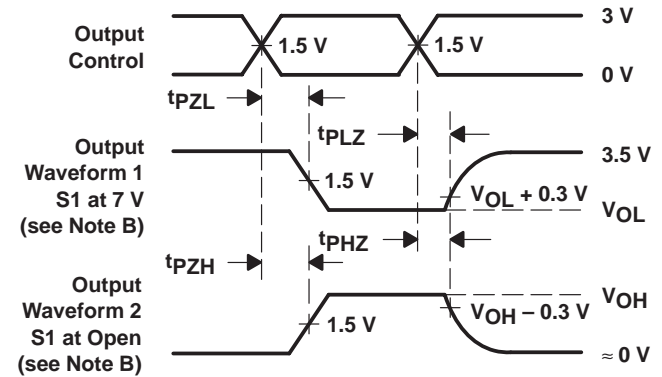

VOLTAGE WAVEFORMS
ENABLE AND DISABLE TIMES
LOW- AND HIGH-LEVEL ENABLING

- NOTES: A. C_L includes probe and jig capacitance.
B. Waveform 1 is for an output with internal conditions such that the output is low except when disabled by the output control. Waveform 2 is for an output with internal conditions such that the output is high except when disabled by the output control.
C. All input pulses are supplied by generators having the following characteristics: $PRR \leq 10 \text{ MHz}$, $Z_O = 50 \Omega$, $t_r \leq 2.5 \text{ ns}$, $t_f \leq 2.5 \text{ ns}$.
D. The outputs are measured one at a time with one transition per measurement.

Figure 1. Load Circuit and Voltage Waveforms

TAPE AND REEL INFORMATION

QUADRANT ASSIGNMENTS FOR PIN 1 ORIENTATION IN TAPE



*All dimensions are nominal

Device	Package Type	Package Drawing	Pins	SPQ	Reel Diameter (mm)	Reel Width W1 (mm)	A0 (mm)	B0 (mm)	K0 (mm)	P1 (mm)	W (mm)	Pin1 Quadrant
SN74ABTH25245DWR	SOIC	DW	24	2000	330.0	24.4	10.75	15.7	2.7	12.0	24.0	Q1

TAPE AND REEL BOX DIMENSIONS

*All dimensions are nominal

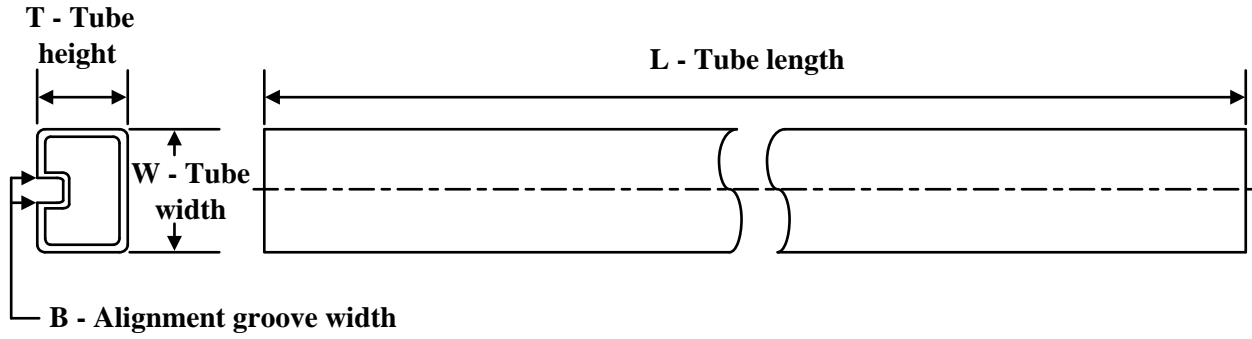
Device	Package Type	Package Drawing	Pins	SPQ	Length (mm)	Width (mm)	Height (mm)
SN74ABTH25245DWR	SOIC	DW	24	2000	350.0	350.0	43.0

TUBE

*All dimensions are nominal

Device	Package Name	Package Type	Pins	SPQ	L (mm)	W (mm)	T (μm)	B (mm)
SN74ABTH25245DW	DW	SOIC	24	25	506.98	12.7	4826	6.6

IMPORTANT NOTICE AND DISCLAIMER

TI PROVIDES TECHNICAL AND RELIABILITY DATA (INCLUDING DATA SHEETS), DESIGN RESOURCES (INCLUDING REFERENCE DESIGNS), APPLICATION OR OTHER DESIGN ADVICE, WEB TOOLS, SAFETY INFORMATION, AND OTHER RESOURCES "AS IS" AND WITH ALL FAULTS, AND DISCLAIMS ALL WARRANTIES, EXPRESS AND IMPLIED, INCLUDING WITHOUT LIMITATION ANY IMPLIED WARRANTIES OF MERCHANTABILITY, FITNESS FOR A PARTICULAR PURPOSE OR NON-INFRINGEMENT OF THIRD PARTY INTELLECTUAL PROPERTY RIGHTS.

These resources are intended for skilled developers designing with TI products. You are solely responsible for (1) selecting the appropriate TI products for your application, (2) designing, validating and testing your application, and (3) ensuring your application meets applicable standards, and any other safety, security, regulatory or other requirements.

These resources are subject to change without notice. TI grants you permission to use these resources only for development of an application that uses the TI products described in the resource. Other reproduction and display of these resources is prohibited. No license is granted to any other TI intellectual property right or to any third party intellectual property right. TI disclaims responsibility for, and you will fully indemnify TI and its representatives against, any claims, damages, costs, losses, and liabilities arising out of your use of these resources.

TI's products are provided subject to [TI's Terms of Sale](#) or other applicable terms available either on [ti.com](https://www.ti.com) or provided in conjunction with such TI products. TI's provision of these resources does not expand or otherwise alter TI's applicable warranties or warranty disclaimers for TI products.

TI objects to and rejects any additional or different terms you may have proposed.

Mailing Address: Texas Instruments, Post Office Box 655303, Dallas, Texas 75265
Copyright © 2023, Texas Instruments Incorporated

Looking for pricing, stock, or lifecycle information?

Click below to explore more details on WIN SOURCE:

 [View SN74ABTH25245DWR on WIN SOURCE](#)

 [Texas Instruments](#) Information

Optimize Your Supply Chain with WIN SOURCE Solutions

-  Global Sourcing Solution
-  Obsolete Management
-  Cost Control Management
-  Shortage Management
-  Alternative Solution
-  Excess Inventory Management