



THE DATASHEET OF SN65LVPE501RGER



Dual Channel x1 PCIe Redriver/Equalizer

Check for Samples: [SN65LVPE501](#)

FEATURES

- Single Lane PCIe Equalizer/Redriver
- Support for Both PCIe Gen I (2.5Gbps) and Gen II (5.0 Gbps) Speed
- Selectable Equalization, De-emphasis and Output Swing Control
- Integrated Termination
- Hot-Plug Capable
- Receiver Detect
- Low Power:
 - 330mW(TYP), $V_{CC} = 3.3V$
- Auto Low Power Modes:
 - 5mW (TYP) When no Connection Detected
 - 70mW (TYP) When in Auto-Low Power Mode

- Excellent Jitter and Loss Compensation Capability:
 - 30" of 6 mil Stripline on FR4
- Small Foot Print – 24 Pin 4 x 4 QFN Package
- High Protection Against ESD Transient
 - HBM: 3,000 V
 - CDM: 1,500 V
 - MM: 200 V

APPLICATIONS

- PC MB, Docking Stations, Backplane and Cabled Application

DESCRIPTION

The SN65LVPE501 is a dual channel, single lane PCIe redriver and signal conditioner supporting data rates of up to 5.0Gbps. The device complies with PCIe spec revision 2.1.

Programmable EQ, De-Emphasis and Amplitude Swing

The SN65LVPE501 is designed to minimize the signal degradation effects such as crosstalk and inter-symbol interference (ISI) that limits the interconnect distance between two devices. The input stage of each channel offers selectable equalization settings that can be programmed to match loss in the channel. The differential outputs provide selectable de-emphasis to compensate for the anticipated distortion PCIe signal will experience. Level of de-emphasis will depend on the length of interconnect and its characteristics. Both equalization and de-emphasis levels are controlled by the setting of signal control pins EQ1, EQ2 and DE1, DE2.

To provide additional control of signal integrity in extended backplane applications LVPE501 provides independent output amplitude control for each channel. See [Table 2](#) for setting details.

Device PowerOn

Device initiates internal power-on reset after V_{CC} has stabilized. External reset can also be applied at anytime by toggling \overline{RST} pin. External reset is recommended after every device power-up. When \overline{RST} is driven high, the device samples the state of EN_RXD, if it is set H device enters Rx.Detect state where each channel will perform Rx.Detect function (as described in PCIe spec). If EN_RXD is set L, automatic RX detect function is disabled and both channels are enabled with their termination set to Z_{DC_RX} .

Receiver Detection

While EN_RXD pin is H and device is not in sleep mode (\overline{RST} is H), SN65LVPE501 performs RX.Detect on both channels indefinitely until remote termination is detected on both channels. Automatic Rx detection feature can be forced off by driving EN_RXD low. In this state both channels input termination are set to Z_{DC_RX} .



Please be aware that an important notice concerning availability, standard warranty, and use in critical applications of Texas Instruments semiconductor products and disclaimers thereto appears at the end of this data sheet.



These devices have limited built-in ESD protection. The leads should be shorted together or the device placed in conductive foam during storage or handling to prevent electrostatic damage to the MOS gates.

DESCRIPTION CONTINUED

Sleep (Shut_Down) Mode

This is low power state triggered by $\overline{\text{RST}} = \text{L}$. In sleep mode receiver termination resistor for each of the two channels is switched to $Z_{\text{RX-HIGH_IMP}}$ of $>50 \text{ K}\Omega$ and transmitters are pulled to Hi-Z state. Device power is reduced to $<1\text{mW}$ (TYP). To get device out of sleep mode $\overline{\text{RST}}$ is toggled L-H.

Electrical Idle Support

A link is in an electrical idle state when the $\text{TX}\pm$ voltage is held at a steady constant value like the common mode voltage. SN65LVPE501 detects an electrical idle state when $\text{RX}\pm$ input voltage of the associated channel falls below $V_{\text{EID_TH min}}$. After detection of an electrical idle state in a given channel the device asserts electrical idle state in its corresponding TX. When $\text{RX}\pm$ voltage exceeds $V_{\text{EID_TH max}}$, normal device operation is restored and output starts passing input signal. Electrical idle exit and entry time is specified at $\leq 6\text{ns}$.

Electrical idle support is independent for each channel.

Power Save Features

The device supports three power save modes as described below.

1. Sleep (Shut_Down) Mode

This mode can be enabled from any state (Rx detect or active) by driving $\overline{\text{RST}} = \text{L}$. In this state both channels have their termination set to $Z_{\text{RX-HIGH_IMP+}}$ and outputs are at Hi-Z. Device power is 1mW (MAX)

2. Auto Low Power Mode

This mode is enabled when PS pin is tied H and device is in active mode. In this mode anytime $V_{\text{in_diff_pp}}$ falls below selected $V_{\text{EID_TH}}$ for a *given channel* and stays below $V_{\text{EID_TH}}$ for $>1\mu\text{s}$ (TYP), the associated CH will enter auto low power (ALP) mode where power/CH will be reduced to $<1/3^{\text{rd}}$ of normal operating power/CH or about 70mW under typical voltage of 3.3V when ALP conditions are met for both channels. A CH will exit ALP mode whenever $V_{\text{in_diff_pp}}$ exceeds $\text{max } V_{\text{EID_TH}}$ for that channel. Exit latency is 30ns max. To use this mode link latency will need to account for the ALP exit time for N_FTS. ALP mode is handled by each channel independently based on its input differential signal level. This mode can be disabled by leaving PS as NC or tying PS to GND via $4.7\text{k}\Omega$.

3. Cable Disconnect Mode

This mode is activated when $\overline{\text{RST}}$ is H, $\text{EN_RXD} = \text{H}$, and no termination is detected by either channel. Device is in the Rx.Detect state whereby it is continuously performing Rx.Detect on both channels. In this state total power consumed by device is typically $<3\%$ of normal active power. Or $<10\text{mW}$ (MAX).

Beacon Support

With its broadband design, the SN65LVPE501 supports low frequency Beacon signal (as defined by PCIe 2.1 spec) used to indicate wake-up event to the system by a downstream device when in L2 power state. All requirements for a beacon signal as specified in PCI Express specification 2.1 must be met for device to pass beacon signals.

Devic Power

The SN65LVPE501 is designed to operate from a single 3.3V supply. Always practice proper supply sequencing procedure. Apply V_{CC} first before any input control pin signals are applied to the device. Power-down sequence is in reverse order.

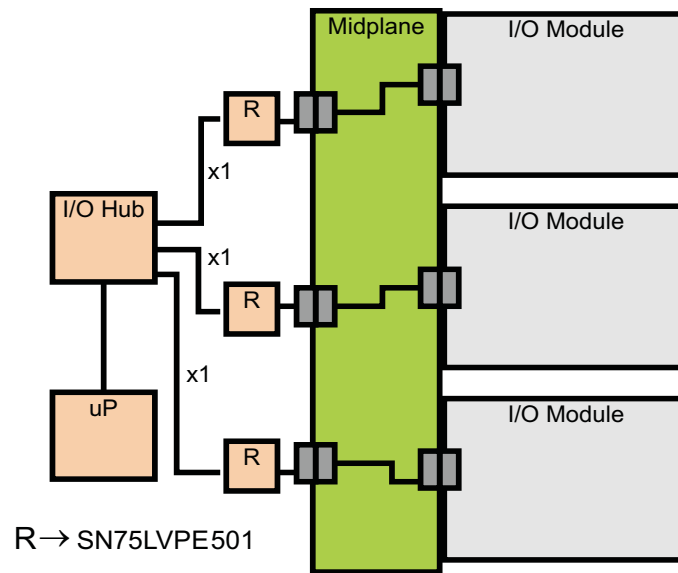
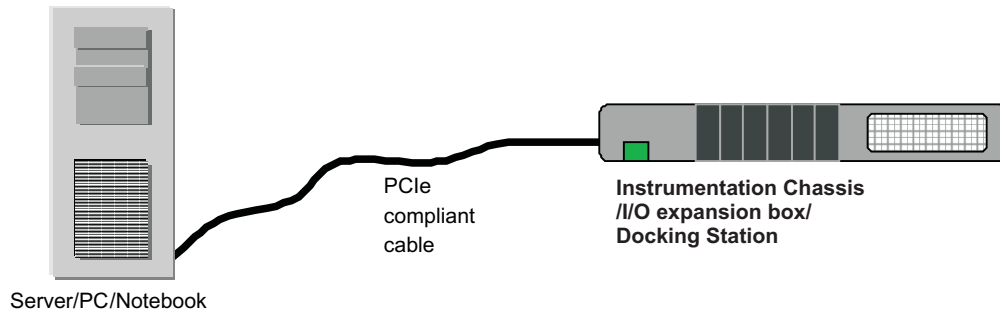

Figure 1. SN65LVPE501 Typical Applications

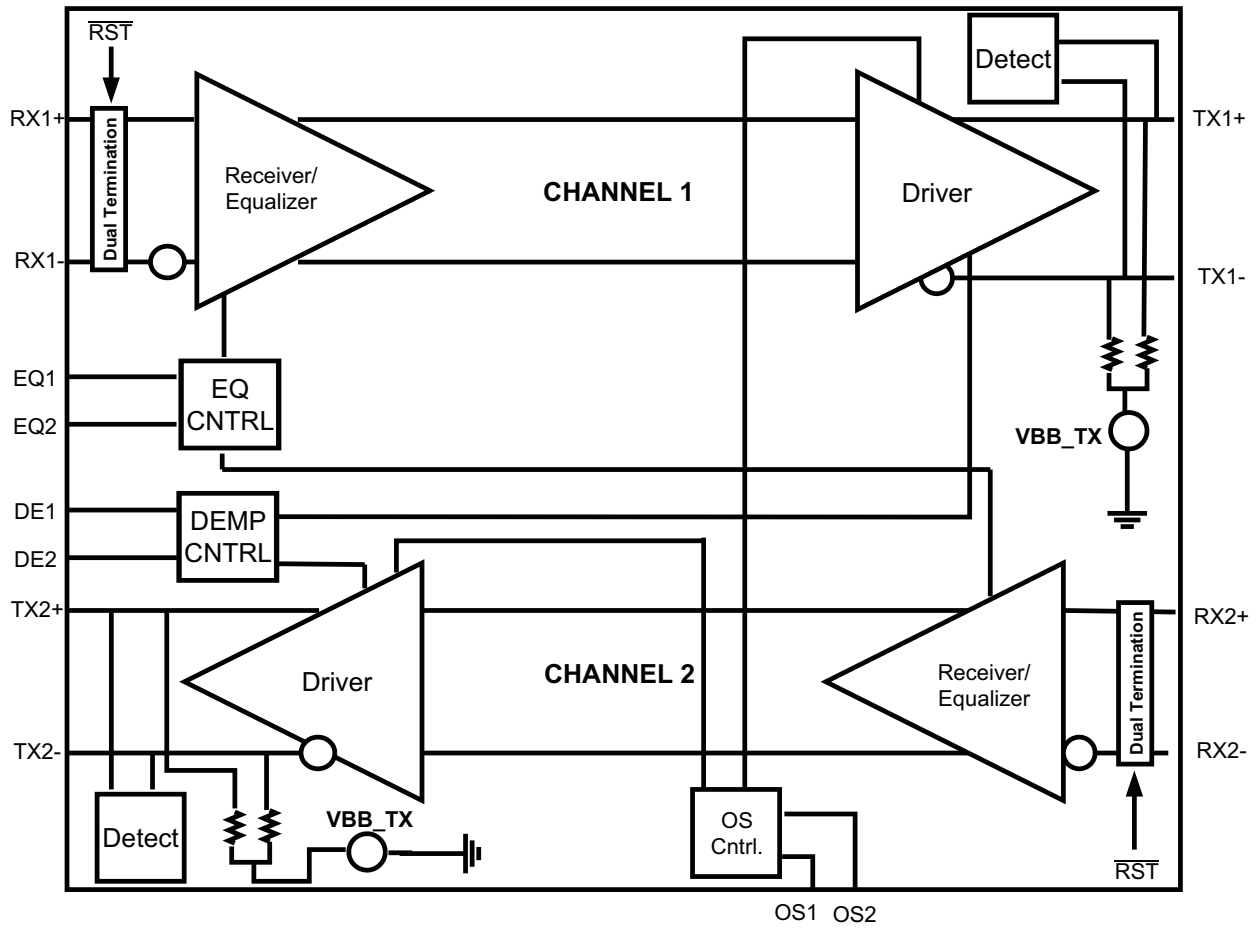
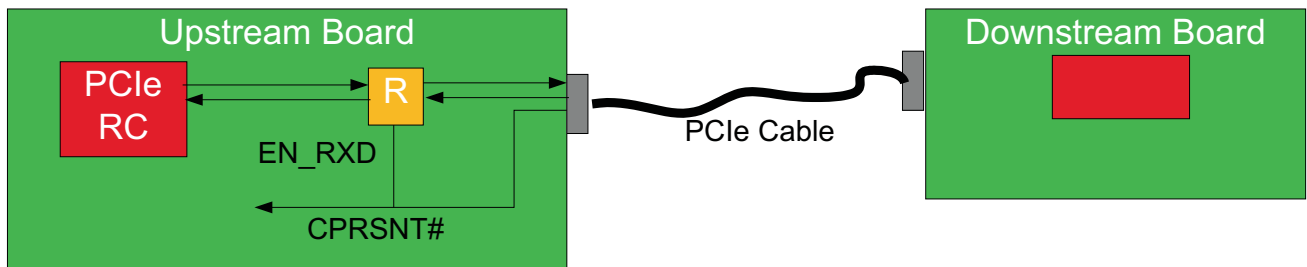

Figure 2. Data Flow Block Diagram

Split System



Enclosed System

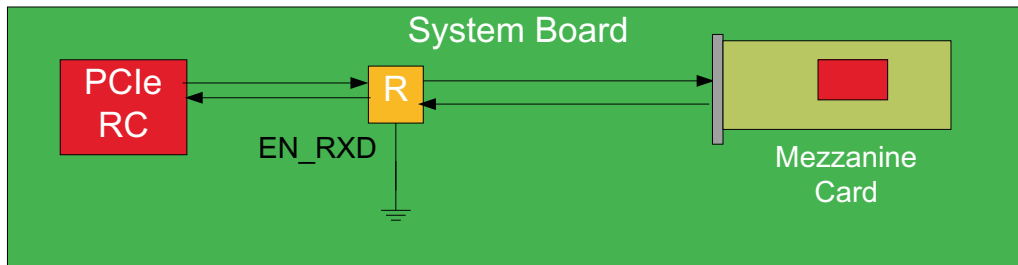

Figure 3. Typical Implementation

Table 1. Pin Description

| PIN | | | |
|--|-------------------------|-----------|---|
| NUMBER | NAME | I/O TYPE | DESCRIPTION |
| HIGH SPEED DIFFERENTIAL I/O PINS | | | |
| 8 | RX1+ | I, CML | Non-inverting and inverting CML differential input for CH 1 and CH 2. These pins are tied to an internal voltage bias by dual termination resistor circuit. |
| 9 | RX1– | I, CML | |
| 20 | RX2+ | I, CML | |
| 19 | RX2– | I, CML | |
| 23 | TX1+ | O, CML | Non-inverting and inverting CML differential output for CH 1 and CH 2. These pins are internally tied to voltage bias by termination resistors. |
| 22 | TX1– | O, CML | |
| 11 | TX2+ | O, CML | |
| 12 | TX2– | O, CML | |
| DEVICE CONTROL PIN⁽¹⁾ | | | |
| 5 | EN_RXD | I, LVCMOS | Sets device operation modes per Table 2 . Internally pulled to VCC |
| 14 | PS | I, LVCMOS | Select auto-low power save mode per Table 2 . Internally pulled to GND |
| 7 | $\overline{\text{RST}}$ | I, LVCMOS | Reset device, input active Low. Internally pulled to VCC |
| 24 | RSVD | I, LVCMOS | Reserved for factory test. Must be connected to GND |
| SIGNAL CONTROL PINS⁽²⁾ | | | |
| 3,16 | DE1, DE2 | I, LVCMOS | Selects de-emphasis settings for CH 1 and CH 2 per Table 2 . Internally tied to $V_{CC}/2$ |
| 2,17 | EQ1, EQ2 | I, LVCMOS | Selects equalization settings for CH 1 and CH 2 per Table 2 . Internally tied to $V_{CC}/2$ |
| 4, 15 | OS1, OS2 | I, LVCMOS | Selects output amplitude for CH 1 and CH 2 per Table 2 . Internally tied to $V_{CC}/2$ |
| POWER PINS | | | |
| 1,13 | VCC | Power | Positive supply should be $3.3V \pm 10\%$ |
| 6,10,18,21 | GND | Power | Supply ground |

(1) When not used can be left as NC or connected to V_{CC}/GND via 4.7k Ω resistor.

(2) Internally biased to $V_{CC}/2$ with >200k Ω pullup/pulldown. When 3-state pins are left as NC board leakage at the pin pad must be <1 μA otherwise drive to $V_{CC}/2$ to assert mid-level state.

Table 2. Signal Control Pin Setting

| OS_x | | TRANSITION BIT AMPLITUDE (TYP mVpp) | |
|-------------------------------------|--|---|---|
| NC | | 1000 | |
| 0 | | 875 | |
| 1 | | 1100 | |
| DEx⁽¹⁾ | OS_x⁽¹⁾ = NC | OS_x⁽¹⁾ = 0 | OS_x⁽¹⁾ = 1 |
| NC | -3.7 dB | -2.5 dB | -4.6 dB |
| 0 | -6.4 dB | -5.5 dB | -6.6 dB |
| 1 | -9.4 dB | -9.5 dB | -8.7 dB |
| EQ_x⁽¹⁾ | | EQUALIZATION dB (At GenII Speed) | |
| NC | | 0 | |
| 0 | | 7 | |
| 1 | | 15 | |
| EN_RXD | | DEVICE FUNCTION | |
| 0 | | Set input termination to Z _{DC_RX} and disable Rx. Detect | |
| 1 | | Perform Rx.Detect (default , internally pulled to Vcc) | |
| RST | | DEVICE FUNCTION | |
| 0 | | Device in quiescent state and inputs set to Hi-Z | |
| 1 | | Device not in shut_down mode (default , internally pulled to Vcc) | |
| PS | | DEVICE FUNCTION | |
| 0 | | Auto-low power mode disabled (default , internally pulled to GND) | |
| 1 | | Auto-low power mode enabled | |

(1) Applies to Channel 1 and Channel 2 at 2.5 GHz.

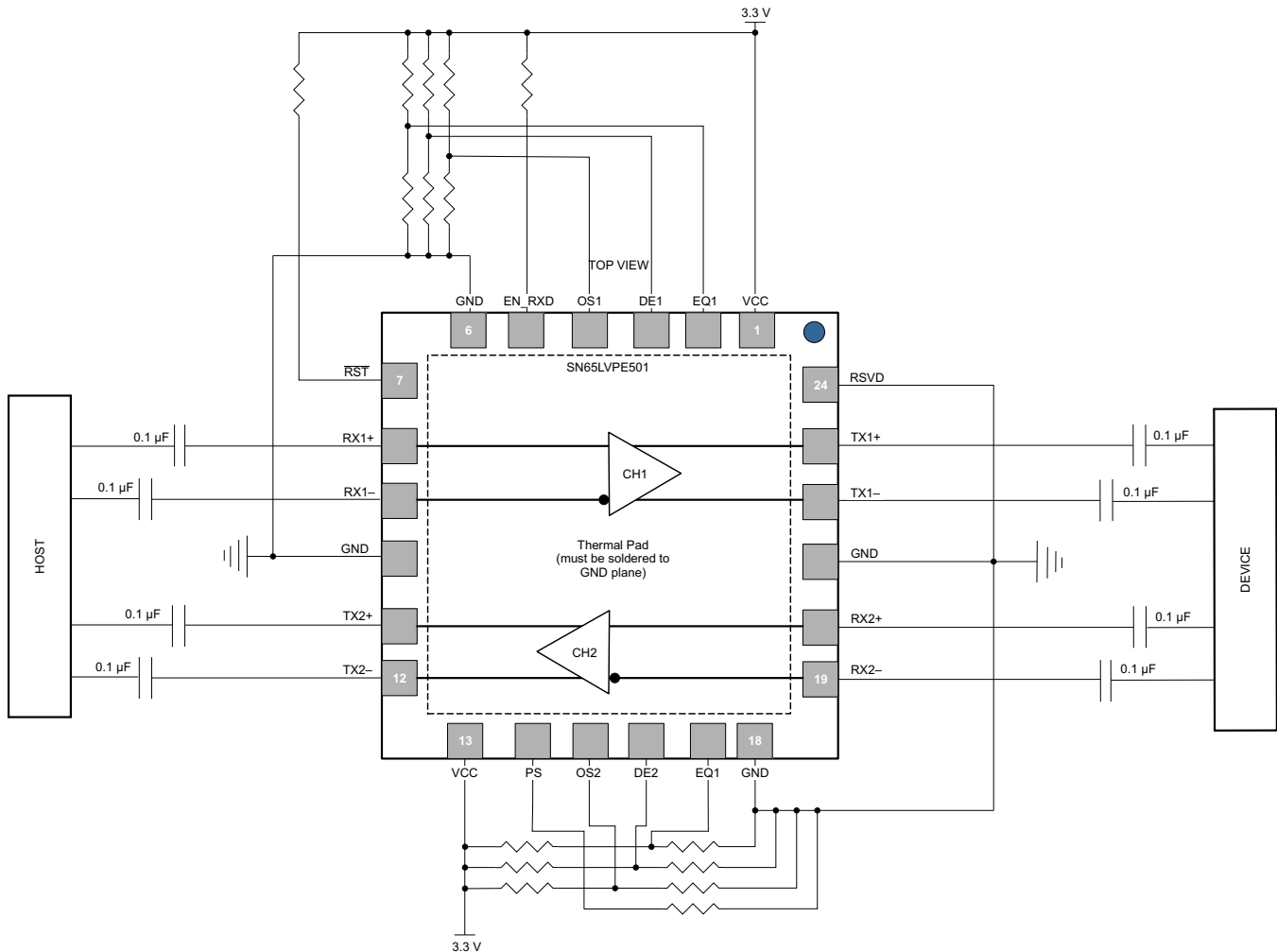

- (1) This is a reference example and it is not intended to represent the best configuration; every designer should select the EQ and DE settings that better fits the system needs. All DEx, EQx and OSx pins default to NC.
- (2) The recommended value for all the resistors shown in the Figure is 4.9K Ω .
- (3) For terminals OSx, DEx, and EQx, populate only pull-up or only pull-down according to the desired setting.

Figure 4. Reference Device Implementation

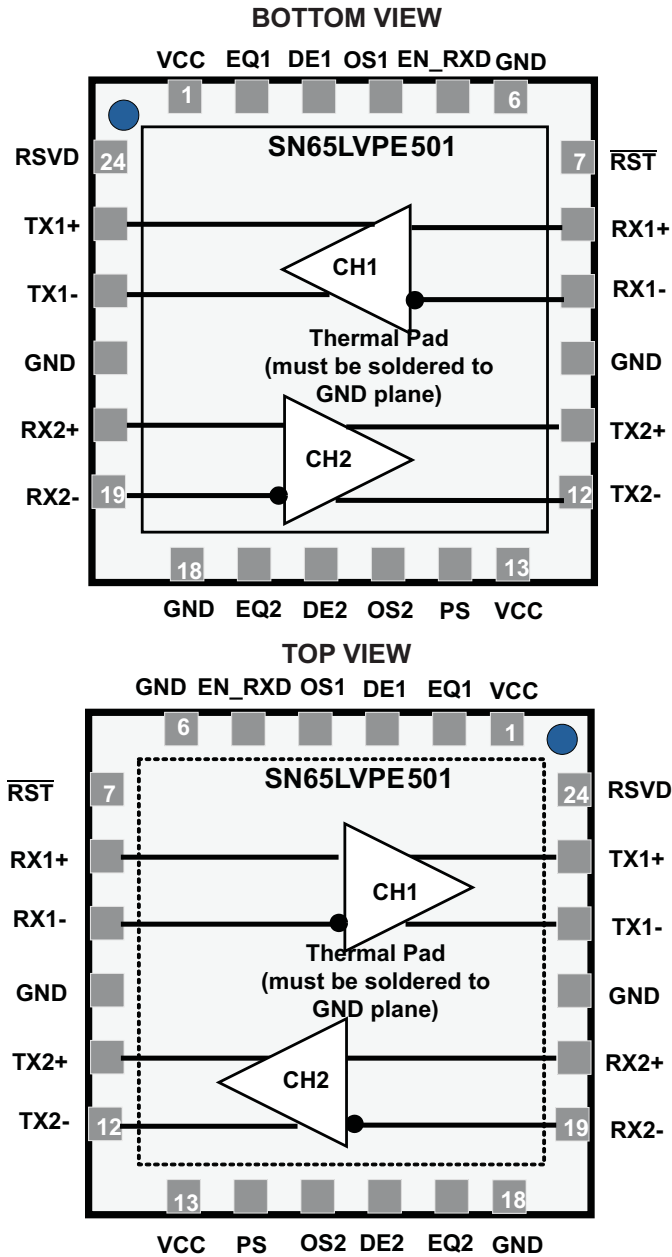

Figure 5. Flow-Through Pin-Out

ORDERING INFORMATION⁽¹⁾

| PART NUMBER | PART MARKING | PCAKAGE |
|-----------------|--------------|-------------------------|
| SN65LVPE501RGER | LVPE501 | 24-pin RGE Reel (large) |
| SN65LVPE501RGET | LVPE501 | 24-pin RGE Reel (small) |

(1) For the most current package and ordering information, see the Package Option Addendum at the end of this document, or see the TI web site at www.ti.com.

ABSOLUTE MAXIMUM RATINGS

over operating free-air temperature range (unless otherwise noted)⁽¹⁾

| | | UNIT / VALUES |
|-------------------------------------|--|---------------------------------|
| Supply Voltage Range ⁽²⁾ | V _{CC} | –0.5 V to 4 V |
| Voltage Range | Differential I/O | –0.5V to 4 V |
| | Control I/O | –0.5 V to V _{CC} + 0.5 |
| Electrostatic Discharge | (Human Body Model) QSS 009-105 (JESD22-A114B) | ±3000 V |
| | (Charged Device Model) QSS 009-147 (JESD22-C101-A) | ±1500 V |
| | (Machine Model) JESD22-A115-A | ±200 V |
| Continuous power dissipation | | See Thermal Information Table |

- (1) Stresses beyond those listed under absolute maximum ratings may cause permanent damage to the device. These are stress ratings only and functional operation of the device at these or any conditions beyond those indicated under recommended operating conditions is not implied. Exposure to absolute-maximum-rated conditions for extended periods may affect device reliability.
- (2) All voltage values, except differential voltages, are with respect to network ground terminal.

THERMAL INFORMATION

| THERMAL METRIC ⁽¹⁾ | | SN65LVPE501 | UNITS |
|-------------------------------|---|-------------|-------|
| | | RGE | |
| | | 24 PINS | |
| θ_{JA} | Junction-to-ambient thermal resistance ⁽²⁾ | 46 | °C/W |
| $\theta_{JC(TOP)}$ | Junction-to-case(top) thermal resistance ⁽³⁾ | 42 | |
| θ_{JB} | Junction-to-board thermal resistance ⁽⁴⁾ | 13 | |
| ψ_{JT} | Junction-to-top characterization parameter ⁽⁵⁾ | 0.5 | |
| ψ_{JB} | Junction-to-board characterization parameter ⁽⁶⁾ | 9 | |
| $\theta_{JC(BOTTOM)}$ | Junction-to-case(bottom) thermal resistance ⁽⁷⁾ | 4 | |

- (1) For more information about traditional and new thermal metrics, see the *IC Package Thermal Metrics* application report, [SPRA953](#).
- (2) The junction-to-ambient thermal resistance under natural convection is obtained in a simulation on a JEDEC-standard, high-K board, as specified in JESD51-7, in an environment described in JESD51-2a.
- (3) The junction-to-case (top) thermal resistance is obtained by simulating a cold plate test on the package top. No specific JEDEC-standard test exists, but a close description can be found in the ANSI SEMI standard G30-88.
- (4) The junction-to-board thermal resistance is obtained by simulating in an environment with a ring cold plate fixture to control the PCB temperature, as described in JESD51-8.
- (5) The junction-to-top characterization parameter, ψ_{JT} , estimates the junction temperature of a device in a real system and is extracted from the simulation data for obtaining θ_{JA} , using a procedure described in JESD51-2a (sections 6 and 7).
- (6) The junction-to-board characterization parameter, ψ_{JB} , estimates the junction temperature of a device in a real system and is extracted from the simulation data for obtaining θ_{JA} , using a procedure described in JESD51-2a (sections 6 and 7).
- (7) The junction-to-case (bottom) thermal resistance is obtained by simulating a cold plate test on the exposed (power) pad. No specific JEDEC standard test exists, but a close description can be found in the ANSI SEMI standard G30-88.

RECOMMENDED OPERATING CONDITIONS

over operating free-air temperature range (unless otherwise noted)

| | | MIN | TYP | MAX | UNIT |
|-----------------------|--------------------------------|-----|-----|-----|------|
| V _{CC} | Supply Voltage | 3 | 3.3 | 3.6 | V |
| C _{COUPLING} | AC Coupling Capacitor | 75 | | 200 | nF |
| | Operating free-air temperature | -40 | | 85 | °C |

ELECTRICAL CHARACTERISTICS

over operating free-air temperature range (unless otherwise noted)

| PARAMETER | | TEST CONDITIONS | MIN | TYP | MAX | UNIT |
|---|--------------------------------------|---|-------------------------------------|-----|-----------------|-------|
| DEVICE PARAMETERS (under recommended operating conditions, unless otherwise noted) | | | | | | |
| I _{CC} | Supply Current | $\overline{\text{RST}}$, DE _x , EQ _x , OS _x = NC, EN_RXD = NC, K28.5 pattern at 5 Gbps, V _{ID} = 1000mV _{p-p} | | 101 | 120 | mA |
| ICC _{idle} | | PS=1; When auto-low power conditions are met | | 21 | 26 | |
| ICC _{shut-down} | | $\overline{\text{RST}}$ = GND | | 0.2 | 1 | |
| ICC _{RX.Detect} | | $\overline{\text{RST}}$, EN_RXD = NC | | 2 | | |
| | Maximum Data Rate | | | | 5 | Gbps |
| AutoLP _{ENTRY} | Auto Low Power Entry Time | Electrical Idle at Input, Refer to Figure 9 | 1.0 | 1.3 | | µs |
| AutoLP _{EXIT} | Auto Low Power Exit Time | After first signal activity, Refer to Figure 9 | | 15 | 30 | ns |
| t _{PU} | Power Up Time | Rx_Detect Start Event, V _{cc} = Stable $\overline{\text{RST}}$, EN_RXD = H | | 15 | 30 | µs |
| t _{DIS} | Sleep (shut-down) Mode Entry Time | $\overline{\text{RST}}$ H→L; EN_RXD=X | | | 1 | µs |
| T _{ENB} | Sleep (shut-down) Mode Exit Time | $\overline{\text{RST}}$ L→H; EN_RXD=H, Start of Ex detect event | | | 10 | µs |
| CONTROL LOGIC (under recommended operating conditions, unless otherwise noted) | | | | | | |
| V _{IH} | High level Input Voltage | | 1.4 | | V _{CC} | V |
| V _{IL} | Low Level Input Voltage | | -0.3 | | 0.5 | V |
| V _{HYS} | Input Hysteresis | | | 150 | | mV |
| I _{IH} | High Level Input Current | OS _x , EQ _x , DE _x = V _{CC} | | | 30 | µA |
| | | EN_RXD, $\overline{\text{RST}}$ = V _{CC} | | | 1 | |
| I _{IL} | Low Level Input Current | OS _x , EQ _x , DE _x = GND | -30 | | | µA |
| | | PS = GND | -1 | | | |
| | | EN_RXD, $\overline{\text{RST}}$ = GND | -20 | | | |
| RECEIVER AC/DC (under recommended operating conditions, unless otherwise noted) | | | | | | |
| V _{in,diff,pp} | RX1, RX2 Input Voltage Swing | AC coupled differential signal | 100 | | 1200 | mVp-p |
| V _{CM,RX} | RX1, RX2 Common Mode Voltage | | 0 | | 3.6 | V |
| V _{in,COM,P} | RX1, RX2 AC Peak common mode voltage | | | | 150 | mVP |
| Z _{DC,RX} | DC single ended impedance | | 40 | 50 | 60 | Ω |
| Z _{diff,RX} | DC Differential Input impedance | | 80 | 100 | 120 | Ω |
| Z _{RX,High,IMP+} | DC Input High Impedance | Device in sleep mode Rx termination not powered; Measured with respect to GND over 200mV max | 50 | 74 | | kΩ |
| V _{EID,TH} | Electrical Idle Detect Threshold | Measured at receiver pin (see Figure 7) | 65 | 84 | 175 | mVpp |
| RL _{RX-DIFF} | Differential Return Loss | 50 MHz – 1.25 GHz | | 10 | | dB |
| | | 1.25 GHz – 2.5 GHz | Operating temperature 0°C to 85°C | 8 | | |
| | | | Operating temperature -40°C to 85°C | 7 | | |
| RL _{RX-CM} | Common Mode Return Loss | 50 MHz – 2.5 GHz | | 10 | | dB |

ELECTRICAL CHARACTERISTICS (continued)

over operating free-air temperature range (unless otherwise noted)

| PARAMETER | | TEST CONDITIONS | MIN | TYP | MAX | UNIT | |
|---|--|---|-------------------------------------|------|------|-------|----|
| TRANSMITTER AC/DC (under recommended operating conditions, unless otherwise noted) | | | | | | | |
| V _{TXDIFF_PP} | | R _L = 100Ω ±1%, DEx, OS = NC, Transition Bit | 800 | 1000 | 1200 | mV | |
| | | R _L = 100Ω ±1%, DEx = NC, OSx = GND Transition Bit | 875 | | | | |
| | | R _L = 100Ω ±1%, DEx = NC, OSx = VCC Transition Bit | 1100 | | | | |
| V _{TXDIFF_NTBP} | Differential peak-to-peak Output Voltage | R _L = 100Ω ±1%, DEx=NC, OSx = 0,1,NC Non-Transition Bit | 655 | | | mV | |
| | | R _L = 100Ω ±1%, DEx=0, OSx = 0,1,NC Non-Transition Bit | 495 | | | | |
| | | R _L = 100Ω ±1%, DEx=1, OSx = 0,1, NC Non-Transition Bit | 350 | | | | |
| De-Emphasis Level | | DEx, OSx = NC, See Figure 11 ; (for OS1,2 = 1 and 0 see Table 2) | Operating temperature 0°C to 85°C | -3.0 | -3.7 | -4.0 | dB |
| | | | Operating temperature -40°C to 85°C | -3.0 | -3.7 | -4.2 | |
| | | DEx = 0, OSx = NC | -6.4 | | | dB | |
| | | DEx = 1, OSx = NC | -9.4 | | | | |
| T _{DE} | De-Emphasis Width | At 5Gbps | 0.8 | | | UI | |
| Z _{diff_TX} | DC Differential Impedance | Defined during signaling | 80 | 100 | 120 | Ω | |
| RL _{diff_TX} | Differential Return Loss | f = 50 MHz – 1.25 GHz. | Operating temperature 0°C to 85°C | 10 | | dB | |
| | | | Operating temperature -40°C to 85°C | 9.5 | | | |
| | | f = 1.25 GHz – 2.5 GHz, | Operating temperature 0°C to 85°C | 6 | | | |
| | | | Operating temperature -40°C to 85°C | 5.5 | | | |
| RL _{CM_TX} | Common Mode Return Loss | f = 50 MHz – 2.5 GHz | 10 | | dB | | |
| I _{TX_SC} | TX short circuit current | TX± shorted to GND | 60 | | 90 | mA | |
| V _{TX_CM_DC} | Transmitter DC common-mode voltage | Allowed DC CM voltage at TX pins | 2.1 | 2.65 | 3.1 | V | |
| V _{TX_CM_AC2} | TX AC common mode voltage at GEN II speed | Max(V _{d+} + V _{d-})/2 – Min(V _{d+} + V _{d-})/2 | 26 | | 100 | mVpp | |
| V _{TX_CM_AC1} | TX AC common mode voltage at GEN I speed | | 2 | | 20 | mV | |
| V _{TX_CM_DeltaL0-L0s} | Absolute Delta DC CM voltage during active and idle states | V _{TX_CM_DC [L0]} – V _{TX_CM_DC [L0s]} , PS=L | 0 | | 100 | mV | |
| V _{TX_CM-DC-Line-Delta} | Absolute Delta of DC CM voltage between D+ and D- | V _{TX_CM_DC-D+ [L0]} – V _{TX_CM_DC-D- [L0]} | 0 | | 25 | mV | |
| V _{TX_idle_diff-AC-p} | Electrical idle differential peak output voltage | V _{TX-idle-D+} – V _{TX-idle-D-} HP filtered to remove any DC component | 0 | 1 | 10 | mVpp | |
| V _{TX_idle_diff-DC} | DC Electrical idle differential output voltage | V _{TX_idle-D+} – V _{TX_idle-D-} LP filtered to remove any AC component | 3.5 | | | mV | |
| V _{detect} | Voltage change to allow receiver detect | Positive voltage to sense receiver | | | 600 | mV | |
| t _{R,tF} | Output Rise/Fall time | DEx = NC, OS = NC (CH 0 and CH 1) 20%-80% of differential voltage at the output; VID > 1000mVpp | 30 | 53 | | ps | |
| t _{RF_MM} | Output Rise/Fall time mismatch | DEx = NC, OS = NC (CH 0 and CH 1) 20%-80% of differential voltage at the output | 1 | | 20 | ps | |
| T _{diff_LH} , T _{diff_HL} | Differential Propagation Delay | DEx = NC (CH 0 and CH 1). Propagation delay between 50% level at input and output. See Figure 6 | 280 | 330 | | ps | |
| t _{idleEntry} t _{idleExit} | Idle entry and exit times | See Figure 7 | 4 | | 6 | ns | |
| Tx EQUALIZATION at GEN II Speed (under recommended operating conditions) | | | | | | | |
| T _{TX-TJ} ⁽¹⁾ | Total Jitter | At point A in Figure 10 ⁽²⁾ | 30 | | 50 | ps pp | |
| | | At point B in Figure 10 ⁽²⁾ | 25 | | 80 | | |
| T _{TX-DJ} | Deterministic Jitter | At point A in Figure 10 ⁽²⁾ | 16 | | 30 | ps pp | |
| | | At point B in Figure 10 ⁽²⁾ | 11 | | 60 | | |

 (1) Includes RJ at 10⁻¹²

(2) Refer to Figure 10 with ± K28.5 pattern at 5Gbps, -3.5dB DE from source AWG .

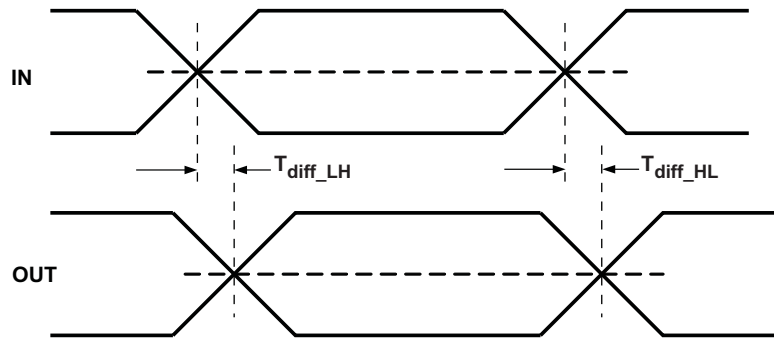

Figure 6. Propagation Delay

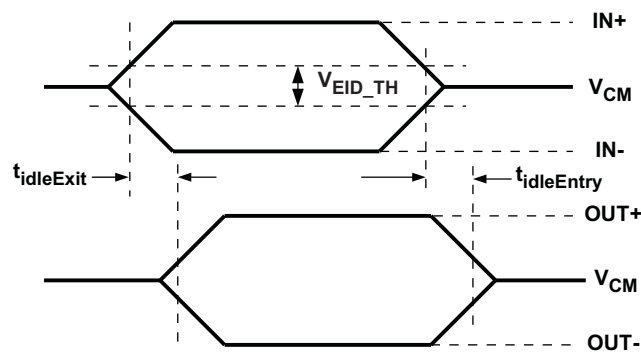

Figure 7. Idle Mode Exit and Entry Delay

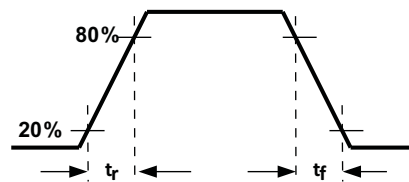

Figure 8. Output Rise and Fall Times

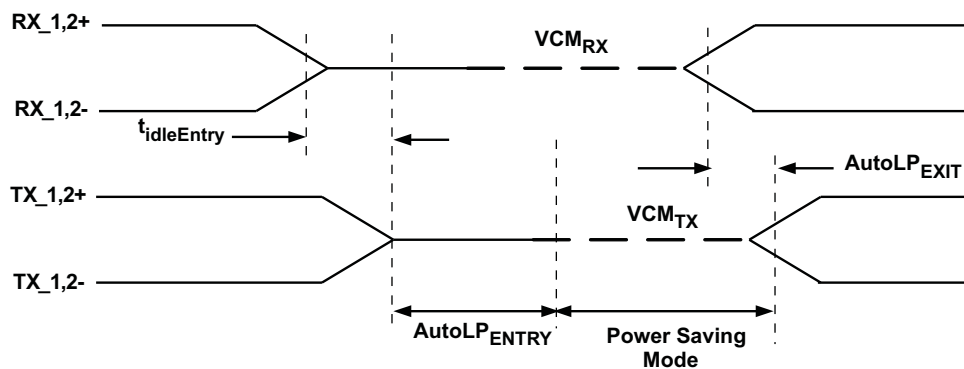

Figure 9. Auto Low Power Mode Timing (when enabled)

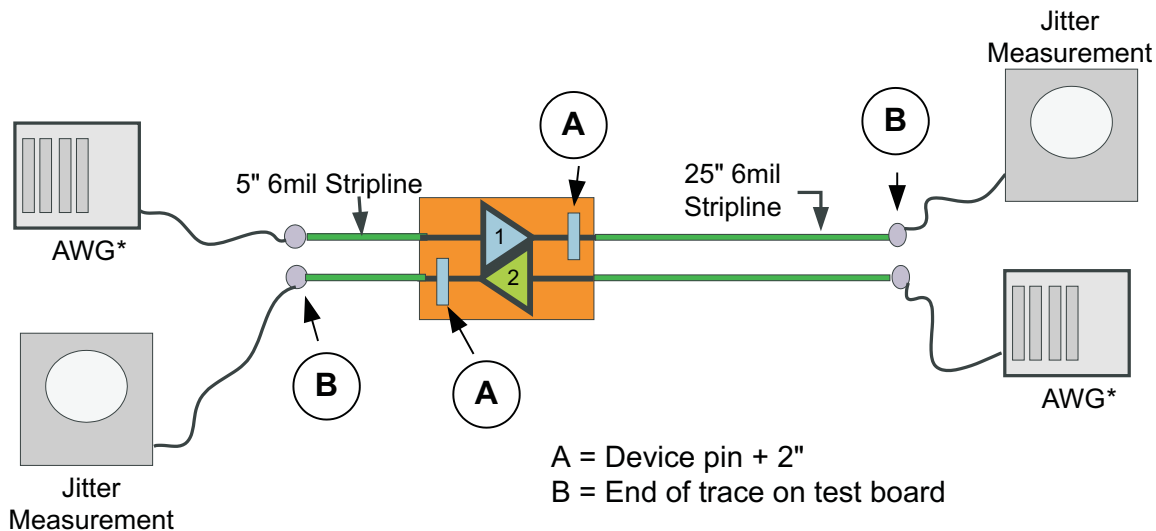

Figure 10. Jitter Measurement Setup

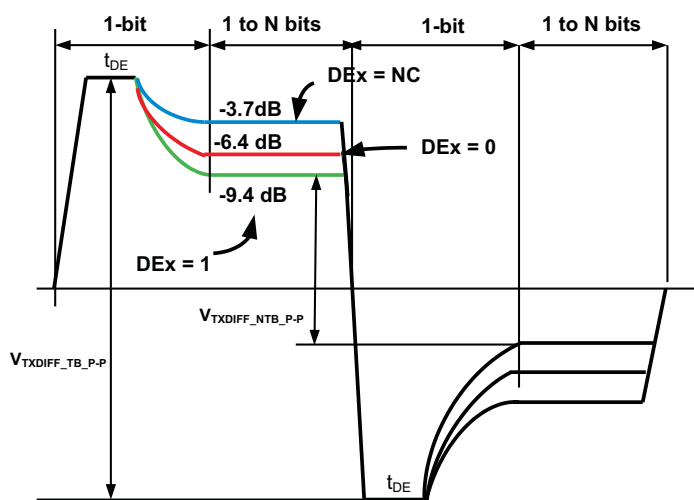

Figure 11. Output De-Emphasis Levels OSx = NC

Typical Eye Diagram and Performance Curves at Output

Input Signal Characteristics: Data Rate = 5 Gbps, $V_{ID} = 1000$ mVpp, DE = -3.5 dB, Pattern = K28.5
 Device Operating Conditions: $V_{CC} = 3.3$ V, Temp = 25°C
 Device EQ settings (EQ/DE/OS) adjusted for best eye performance

Output Trace Length Held Constant and Input Trace Length Varied

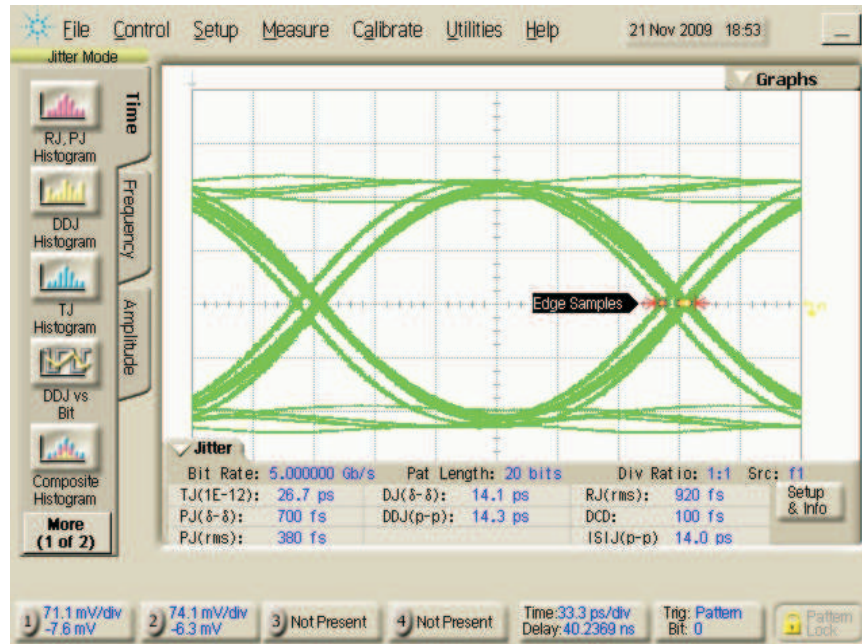

Figure 12. Input Trace = 4 Inches, 6 mil, and Measured at Output Trace = 4 Inches

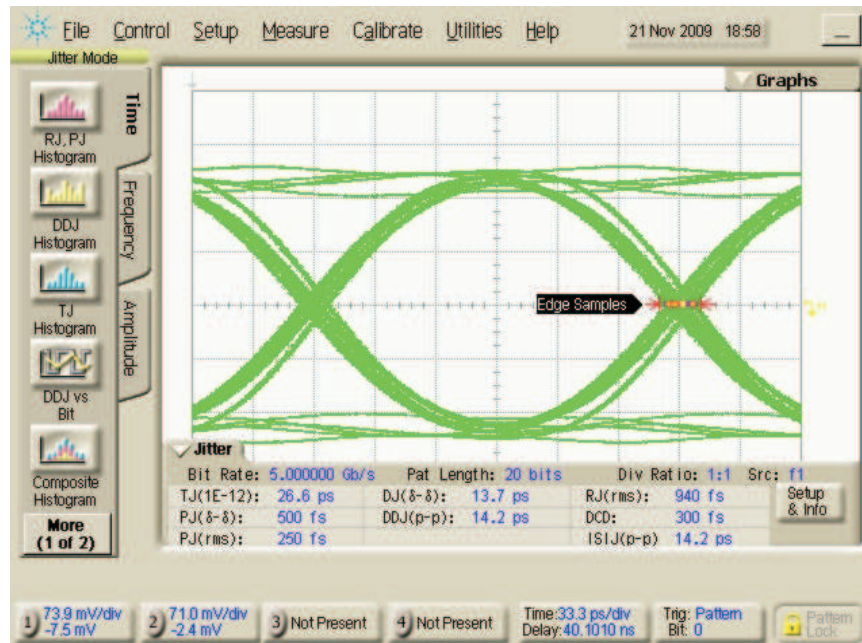

Figure 13. Input Trace = 20 Inches, 6 mil, and Measured at Output Trace = 4 Inches

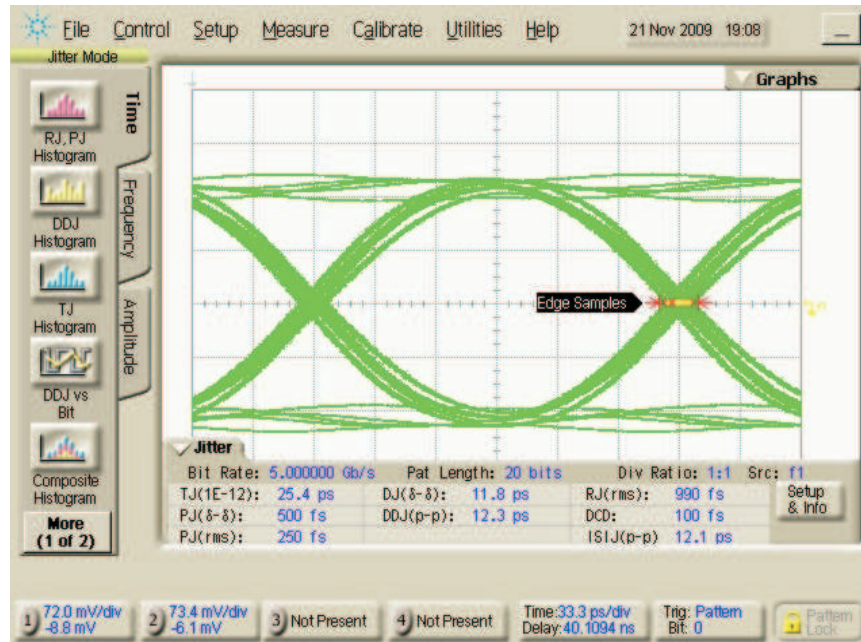

Figure 14. Input Trace = 32 Inches, 6 mil, and Measured at Output Trace = 4 Inches

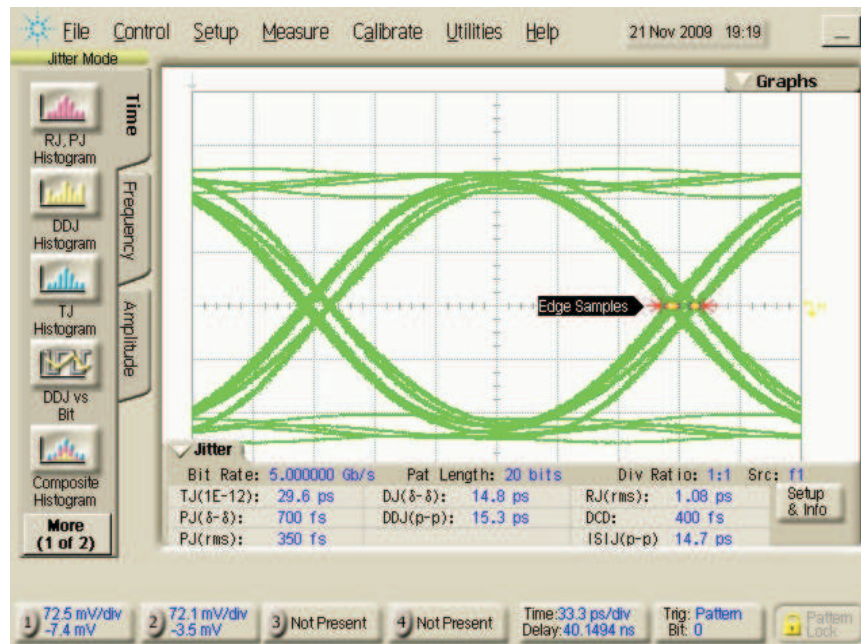

Figure 15. Input Trace = 44 Inches, 6 mil, and Measured at Output Trace = 4 Inches

Variable Trace Lengths at Input and Output

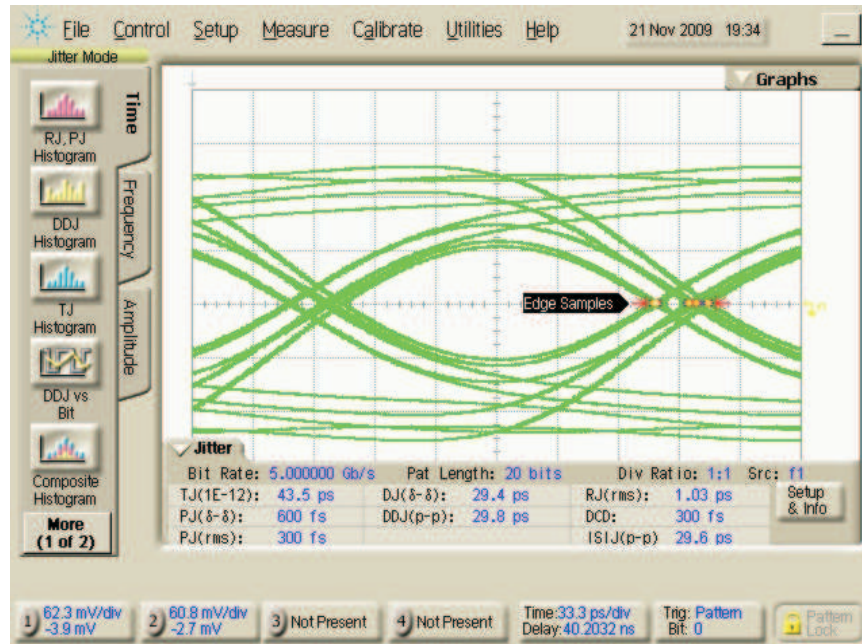

Figure 16. Input Trace = 28 Inches, 6 mil, and Measured at Output Trace = 24 Inches

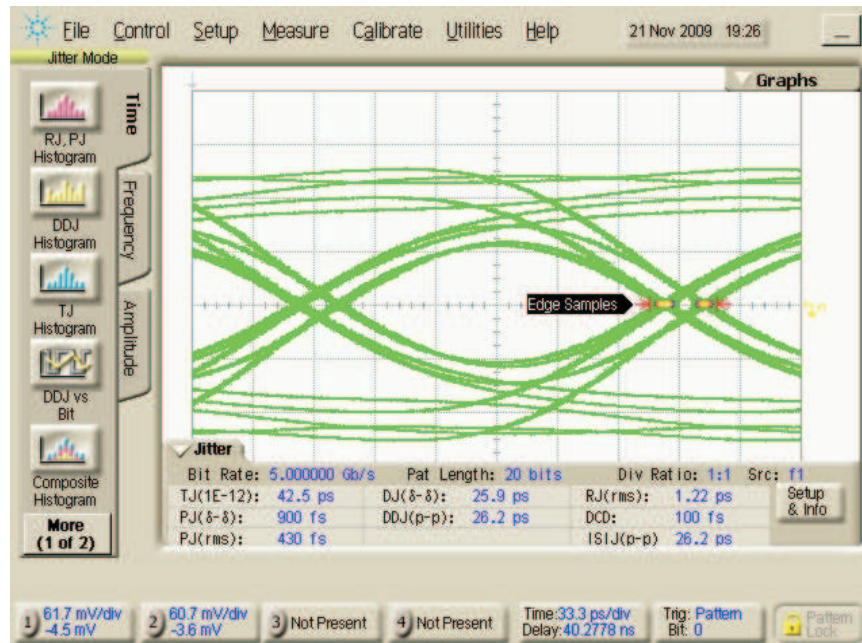

Figure 17. Input Trace = 44 Inches, 6 mil, and Measured at Output Trace = 24 Inches

REVISION HISTORY

| Changes from Original (May 2010) to Revision A | Page |
|--|-------------------|
| • Added Figure 4 | 7 |

PACKAGING INFORMATION

| Orderable Device | Status (1) | Package Type | Package Drawing | Pins | Package Qty | Eco Plan (2) | Lead finish/ Ball material (6) | MSL Peak Temp (3) | Op Temp (°C) | Device Marking (4/5) | Samples |
|------------------|---------------|--------------|--------------------|------|----------------|-----------------|--------------------------------------|----------------------|--------------|-------------------------|-------------------------|
| SN65LVPE501RGER | ACTIVE | VQFN | RGE | 24 | 3000 | RoHS & Green | NIPDAU | Level-2-260C-1 YEAR | -40 to 85 | LVPE501 | Samples |
| SN65LVPE501RGET | ACTIVE | VQFN | RGE | 24 | 250 | RoHS & Green | NIPDAU | Level-2-260C-1 YEAR | -40 to 85 | LVPE501 | Samples |

(1) The marketing status values are defined as follows:

ACTIVE: Product device recommended for new designs.

LIFEBUY: TI has announced that the device will be discontinued, and a lifetime-buy period is in effect.

NRND: Not recommended for new designs. Device is in production to support existing customers, but TI does not recommend using this part in a new design.

PREVIEW: Device has been announced but is not in production. Samples may or may not be available.

OBSOLETE: TI has discontinued the production of the device.

(2) **RoHS:** TI defines "RoHS" to mean semiconductor products that are compliant with the current EU RoHS requirements for all 10 RoHS substances, including the requirement that RoHS substance do not exceed 0.1% by weight in homogeneous materials. Where designed to be soldered at high temperatures, "RoHS" products are suitable for use in specified lead-free processes. TI may reference these types of products as "Pb-Free".

RoHS Exempt: TI defines "RoHS Exempt" to mean products that contain lead but are compliant with EU RoHS pursuant to a specific EU RoHS exemption.

Green: TI defines "Green" to mean the content of Chlorine (Cl) and Bromine (Br) based flame retardants meet JS709B low halogen requirements of <=1000ppm threshold. Antimony trioxide based flame retardants must also meet the <=1000ppm threshold requirement.

(3) MSL, Peak Temp. - The Moisture Sensitivity Level rating according to the JEDEC industry standard classifications, and peak solder temperature.

(4) There may be additional marking, which relates to the logo, the lot trace code information, or the environmental category on the device.

(5) Multiple Device Markings will be inside parentheses. Only one Device Marking contained in parentheses and separated by a "~" will appear on a device. If a line is indented then it is a continuation of the previous line and the two combined represent the entire Device Marking for that device.

(6) Lead finish/Ball material - Orderable Devices may have multiple material finish options. Finish options are separated by a vertical ruled line. Lead finish/Ball material values may wrap to two lines if the finish value exceeds the maximum column width.

Important Information and Disclaimer:The information provided on this page represents TI's knowledge and belief as of the date that it is provided. TI bases its knowledge and belief on information provided by third parties, and makes no representation or warranty as to the accuracy of such information. Efforts are underway to better integrate information from third parties. TI has taken and continues to take reasonable steps to provide representative and accurate information but may not have conducted destructive testing or chemical analysis on incoming materials and chemicals. TI and TI suppliers consider certain information to be proprietary, and thus CAS numbers and other limited information may not be available for release.

In no event shall TI's liability arising out of such information exceed the total purchase price of the TI part(s) at issue in this document sold by TI to Customer on an annual basis.

TAPE AND REEL INFORMATION

QUADRANT ASSIGNMENTS FOR PIN 1 ORIENTATION IN TAPE

*All dimensions are nominal

| Device | Package Type | Package Drawing | Pins | SPQ | Reel Diameter (mm) | Reel Width W1 (mm) | A0 (mm) | B0 (mm) | K0 (mm) | P1 (mm) | W (mm) | Pin1 Quadrant |
|-----------------|--------------|-----------------|------|------|--------------------|--------------------|---------|---------|---------|---------|--------|---------------|
| SN65LVPE501RGER | VQFN | RGE | 24 | 3000 | 330.0 | 12.4 | 4.25 | 4.25 | 1.15 | 8.0 | 12.0 | Q2 |
| SN65LVPE501RGET | VQFN | RGE | 24 | 250 | 180.0 | 12.4 | 4.25 | 4.25 | 1.15 | 8.0 | 12.0 | Q2 |

TAPE AND REEL BOX DIMENSIONS

*All dimensions are nominal

| Device | Package Type | Package Drawing | Pins | SPQ | Length (mm) | Width (mm) | Height (mm) |
|-----------------|--------------|-----------------|------|------|-------------|------------|-------------|
| SN65LVPE501RGER | VQFN | RGE | 24 | 3000 | 356.0 | 356.0 | 35.0 |
| SN65LVPE501RGET | VQFN | RGE | 24 | 250 | 210.0 | 185.0 | 35.0 |

RGE 24

GENERIC PACKAGE VIEW

VQFN - 1 mm max height

PLASTIC QUAD FLATPACK - NO LEAD

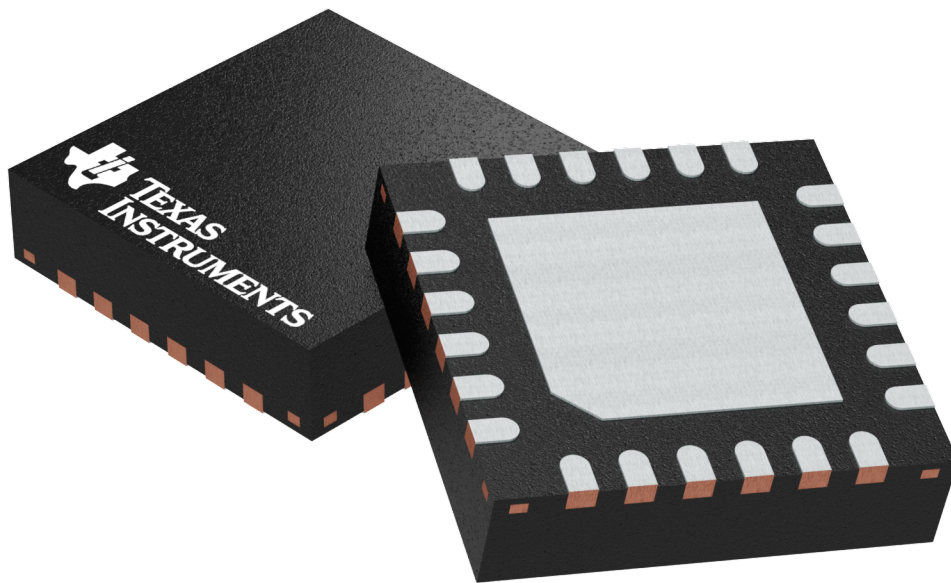

Images above are just a representation of the package family, actual package may vary.
Refer to the product data sheet for package details.

4204104/H

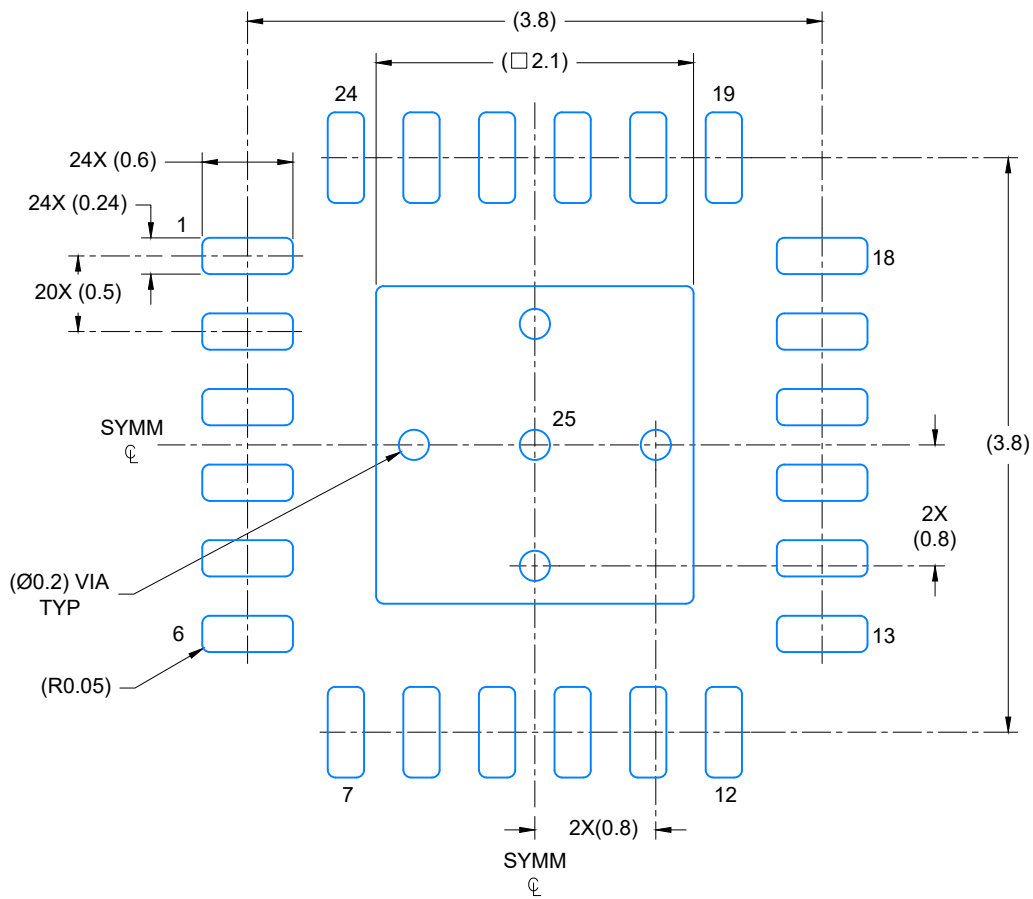

LAND PATTERN EXAMPLE
SCALE: 20X

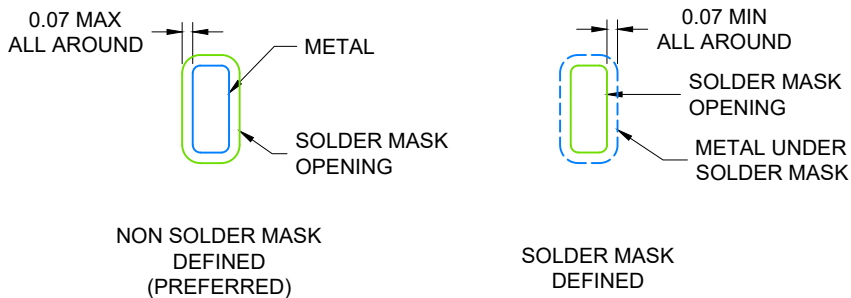

SOLDER MASK DETAILS

4224376 / C 06/2021

NOTES: (continued)

4. This package is designed to be soldered to a thermal pad on the board. For more information, see Texas Instruments literature number SLUA271 (www.ti.com/lit/slua271).
5. Solder mask tolerances between and around signal pads can vary based on board fabrication site.

IMPORTANT NOTICE AND DISCLAIMER

TI PROVIDES TECHNICAL AND RELIABILITY DATA (INCLUDING DATA SHEETS), DESIGN RESOURCES (INCLUDING REFERENCE DESIGNS), APPLICATION OR OTHER DESIGN ADVICE, WEB TOOLS, SAFETY INFORMATION, AND OTHER RESOURCES "AS IS" AND WITH ALL FAULTS, AND DISCLAIMS ALL WARRANTIES, EXPRESS AND IMPLIED, INCLUDING WITHOUT LIMITATION ANY IMPLIED WARRANTIES OF MERCHANTABILITY, FITNESS FOR A PARTICULAR PURPOSE OR NON-INFRINGEMENT OF THIRD PARTY INTELLECTUAL PROPERTY RIGHTS.

These resources are intended for skilled developers designing with TI products. You are solely responsible for (1) selecting the appropriate TI products for your application, (2) designing, validating and testing your application, and (3) ensuring your application meets applicable standards, and any other safety, security, regulatory or other requirements.

These resources are subject to change without notice. TI grants you permission to use these resources only for development of an application that uses the TI products described in the resource. Other reproduction and display of these resources is prohibited. No license is granted to any other TI intellectual property right or to any third party intellectual property right. TI disclaims responsibility for, and you will fully indemnify TI and its representatives against, any claims, damages, costs, losses, and liabilities arising out of your use of these resources.

TI's products are provided subject to [TI's Terms of Sale](#) or other applicable terms available either on ti.com or provided in conjunction with such TI products. TI's provision of these resources does not expand or otherwise alter TI's applicable warranties or warranty disclaimers for TI products.

TI objects to and rejects any additional or different terms you may have proposed.

Mailing Address: Texas Instruments, Post Office Box 655303, Dallas, Texas 75265
Copyright © 2022, Texas Instruments Incorporated

Looking for pricing, stock, or lifecycle information?

Click below to explore more details on WIN SOURCE:

 [View SN65LVPE501RGER on WIN SOURCE](#)

 [Texas Instruments](#) Information

Optimize Your Supply Chain with WIN SOURCE Solutions

-  Global Sourcing Solution
-  Obsolete Management
-  Cost Control Management
-  Shortage Management
-  Alternative Solution
-  Excess Inventory Management