



**THE DATASHEET OF
SN65LVDS93DGG**



LVDS SERDES TRANSMITTER

FEATURES

- **28:4 Data Channel Compression at up to 1.904 Gigabits per Second Throughput**
- **Suited for Point-to-Point Subsystem Communication With Very Low EMI**
- **28 Data Channels Plus Clock in Low-Voltage TTL and 4 Data Channels Plus Clock Out Low-Voltage Differential**
- **Selectable Rising or Falling Clock Edge Triggered Inputs**
- **Bus Pins Tolerate 6-kV HBM ESD**
- **Operates From a Single 3.3-V Supply and 250 mW (Typ)**
- **5-V Tolerant Data Inputs**
- **Packaged in Thin Shrink Small-Outline Package With 20 Mil Terminal Pitch**
- **Consumes <1 mW When Disabled**
- **Wide Phase-Lock Input Frequency Range 20 MHz to 68 MHz**
- **No External Components Required for PLL**
- **Outputs Meet or Exceed the Requirements of ANSI EIA/TIA-644 Standard**
- **Industrial Temperature Qualified $T_A = -40^{\circ}\text{C}$ to 85°C**
- **Replacement for the DS90CR285**

DESCRIPTION

The SN65LVDS93 LVDS serdes (serializer/deserializer) transmitter contains four 7-bit parallel-load serial-out shift registers, a 7-clock synthesizer, and five low-voltage differential signaling (LVDS) drivers in a single integrated circuit. These functions allow 28 bits of single-ended LVTTTL data to be synchronously transmitted over five balanced-pair conductors for receipt by a compatible receiver, such as the SN65LVDS94.

When transmitting, data bits D0 through D27 are each loaded into registers upon the edge of the input clock signal (CLKIN). The rising or falling edge of the clock can be selected via the clock select (CLKSEL) pin. The frequency of CLKIN is multiplied seven times and then used to serially unload the data registers in 7-bit slices. The four serial streams and a phase-locked clock (CLKOUT) are then output to LVDS output drivers. The frequency of CLKOUT is the same as the input clock, CLKIN.

**DGG PACKAGE
(TOP VIEW)**

V _{CC}	1	56	D4
D5	2	55	D3
D6	3	54	D2
D7	4	53	GND
GND	5	52	D1
D8	6	51	D0
D9	7	50	D27
D10	8	49	LVDSGND
V _{CC}	9	48	Y1M
D11	10	47	Y1P
D12	11	46	Y2M
D13	12	45	Y2P
GND	13	44	LVDSV _{CC}
D14	14	43	LVDSGND
D15	15	42	Y3M
D16	16	41	Y3P
CLKSEL	17	40	CLKOUTM
D17	18	39	CLKOUTP
D18	19	38	Y4M
D19	20	37	Y4P
GND	21	36	LVDSGND
D20	22	35	PLL _{GND}
D21	23	34	PLL _{V_{CC}}
D22	24	33	PLL _{GND}
D23	25	32	SHTDN
V _{CC}	26	31	CLKIN
D24	27	30	D26
D25	28	29	GND



Please be aware that an important notice concerning availability, standard warranty, and use in critical applications of Texas Instruments semiconductor products and disclaimers thereto appears at the end of this data sheet.

SN65LVDS93

SLLS302G–MAY 1998–REVISED MAY 2009

www.ti.com



These devices have limited built-in ESD protection. The leads should be shorted together or the device placed in conductive foam during storage or handling to prevent electrostatic damage to the MOS gates.

DESCRIPTION (CONTINUED)

The SN65LVDS93 requires no external components and little or no control. The data bus appears the same at the input to the transmitter and output of the receiver with the data transmission transparent to the user(s). The only user intervention is selecting a clock rising edge by inputting a high level to CLKSEL or a falling edge with a low-level input and the possible use of the shutdown/clear (SHTDN). SHTDN is an active-low input to inhibit the clock and shut off the LVDS output drivers for lower power consumption. A low level on this signal clears all internal registers at a low level.

The SN65LVDS93 is characterized for operation over ambient air temperatures of -40°C to 85°C .

FUNCTIONAL BLOCK DIAGRAM

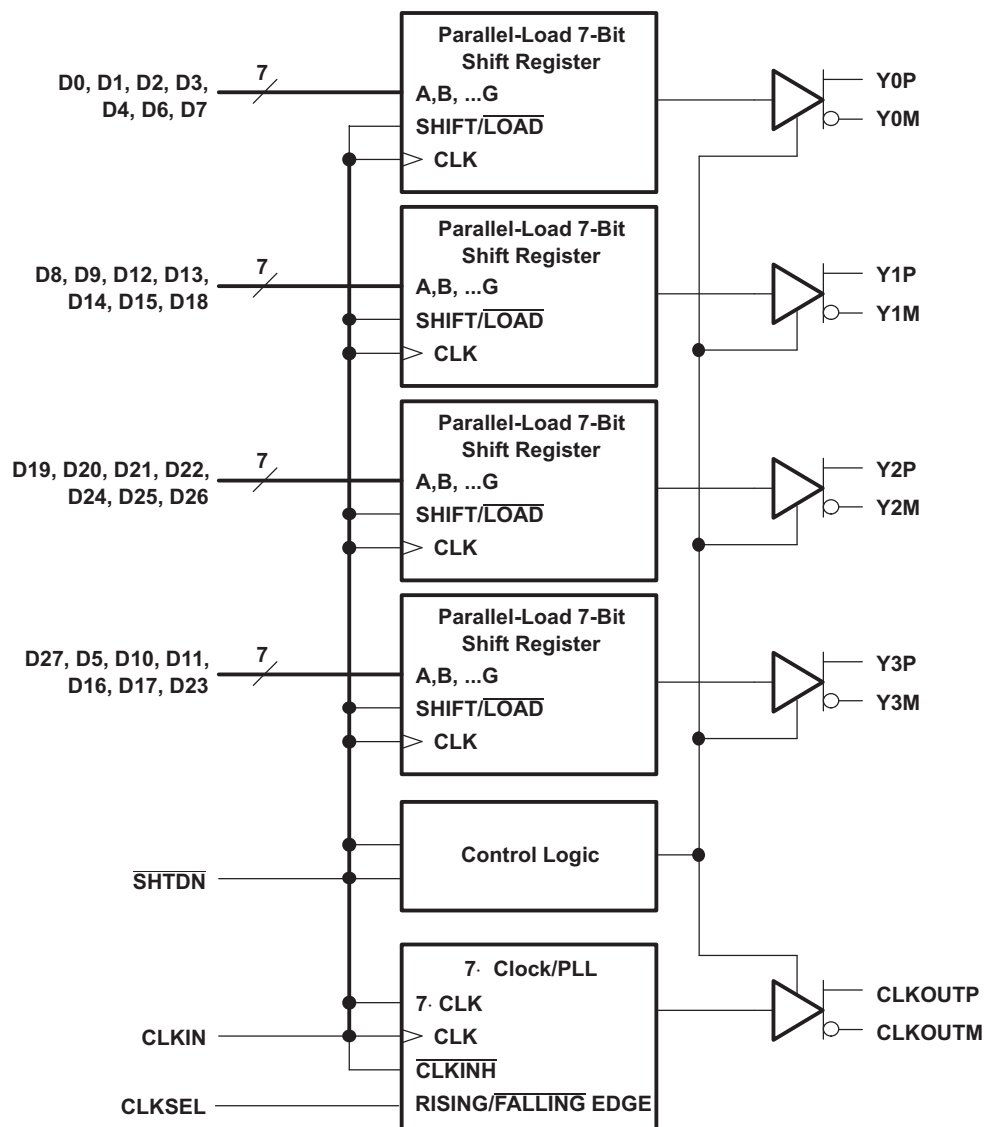

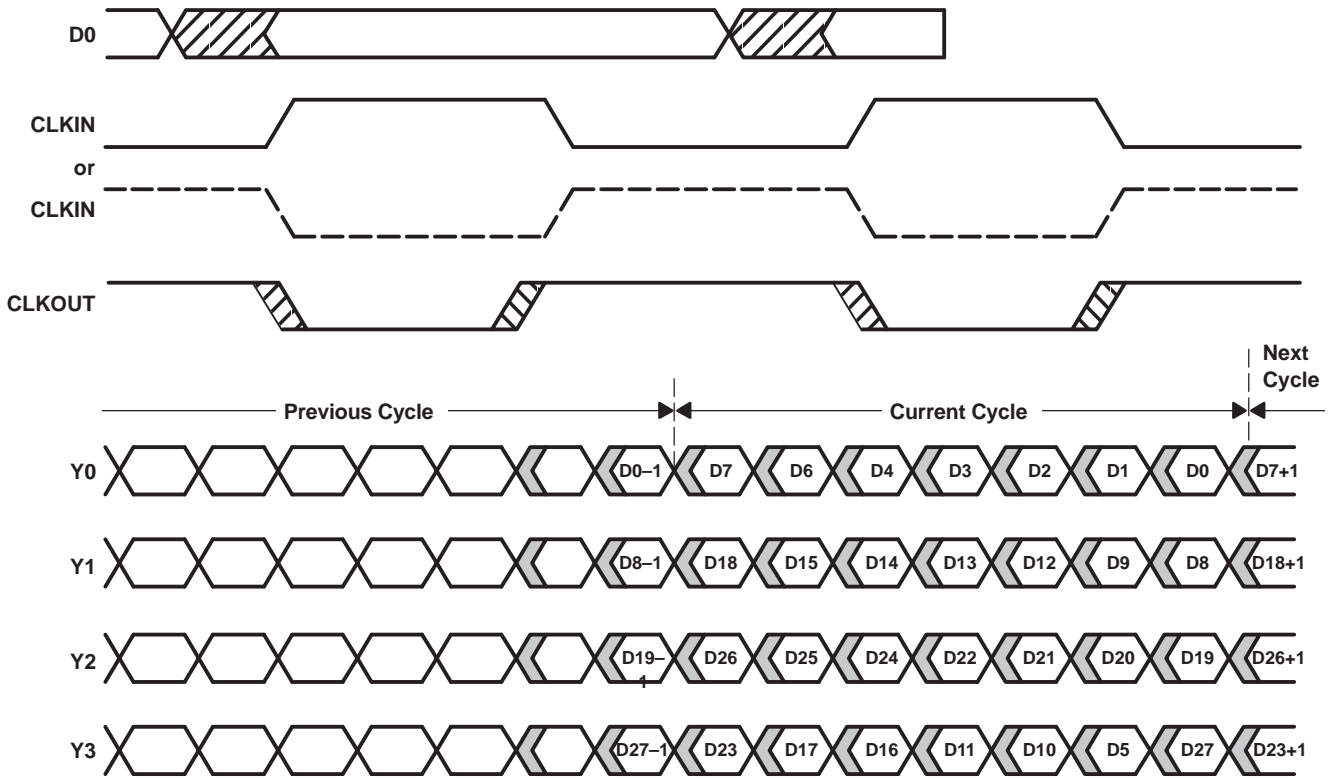
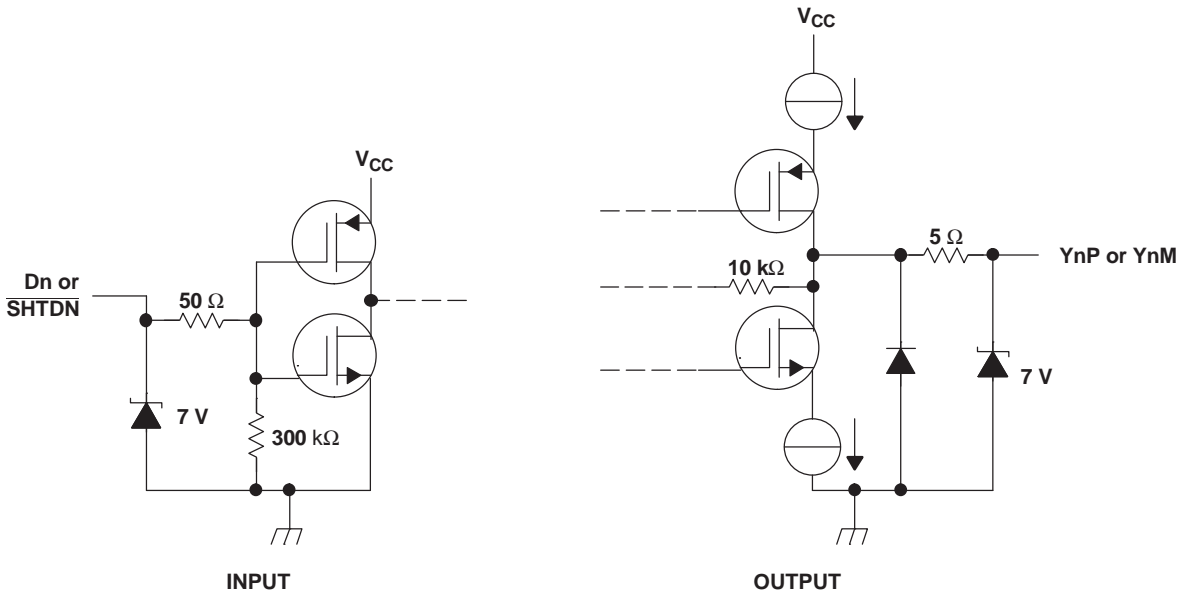

Figure 1. Typical LVDS93 Load and Shift Sequences

EQUIVALENT INPUT AND OUTPUT SCHEMATIC DIAGRAMS



SN65LVDS93

SLLS302G–MAY 1998–REVISED MAY 2009

www.ti.com

ABSOLUTE MAXIMUM RATINGS

 over operating free-air temperature range (unless otherwise noted)⁽¹⁾

		UNIT
V _{CC}	Supply voltage range ⁽²⁾	–0.5 V to 4 V
V _O	Voltage range at any output terminal	–0.5 V to V _{CC} + 0.5 V
V _I	Voltage range at any input terminal	–0.5 V to 5.5 V
Electrostatic discharge ⁽³⁾	Bus Pins (Class 3A)	6 KV
	Bus Pins (Class 2B)	400 V
	Bus Pins (Class 2A)	6 KV
	Bus Pins (Class 2B)	200 V
Continuous total power dissipation		See Dissipation Rating Table
T _A	Operating free-air temperature range	–40°C to 85°C
T _{stg}	Storage temperature range	–65°C to 150°C
Lead temperature 1,6 mm (1/16 inch) from case for 10 seconds		260°C

- (1) Stresses beyond those listed under *absolute maximum ratings* may cause permanent damage to the device. These are stress ratings only, and functional operation of the device at these or any other conditions beyond those indicated under *recommended operating conditions* is not implied. Exposure to absolute-maximum-rated conditions for extended periods may affect device reliability.
- (2) All voltage values are with respect to the GND terminals.
- (3) This rating is measured using MIL-STD-883C Method, 3015.7.

DISSIPATION RATING TABLE

PACKAGE	T _A ≤ 25°C POWER RATING	DERATING FACTOR ⁽¹⁾ ABOVE T _A = 25°C	T _A = 70°C POWER RATING	T _A = 85°C POWER RATING
DGG	1377 mW	11 mW/°C	882 mW	717 mW

- (1) This is the inverse of the junction-to-ambient thermal resistance when board-mounted and with no air flow.

RECOMMENDED OPERATING CONDITIONS

		MIN	NOM	MAX	UNIT
V _{CC}	Supply voltage	3	3.3	3.6	V
V _{IH}	High-level input voltage	2			V
V _{IL}	Low-level input voltage			0.8	V
Z _L	Differential load impedance	90		132	Ω
T _A	Operating free-air temperature	–40		85	°C

ELECTRICAL CHARACTERISTICS

over recommended operating free-air temperature range (unless otherwise noted)

PARAMETER		TEST CONDITIONS	MIN	TYP ⁽¹⁾	MAX	UNIT
V_T	Input voltage threshold			1.4		V
$ V_{OD} $	Differential steady-state output voltage magnitude	$R_L = 100 \Omega$, See Figure 3	247		454	mV
$\Delta V_{OD} $	Change in the steady-state differential output voltage magnitude between opposite binary states				50	mV
$V_{OC(SS)}$	Steady-state common-mode output voltage	See Figure 3	1.125		1.375	V
$V_{OC(PP)}$	Peak-to-peak common-mode output voltage				150	mV
I_{IH}	High-level input current	$V_{IH} = V_{CC}$			20	μA
I_{IL}	Low-level input current	$V_{IL} = 0 V$			± 10	μA
I_{OS}	Short-circuit output current	$V_{OY} = 0 V$			± 24	mA
		$V_{OD} = 0 V$			± 12	mA
I_{OZ}	High-impedance state output current	$V_O = 0 V$ to V_{CC}			± 20	μA
$I_{CC(AVG)}$	Quiescent current (average)	Disabled, All inputs at GND			350	μA
		Enabled, $R_L = 100 \Omega$ (5 places), Worst-case pattern (see Figure 4), $t_c = 15.38 ns$		95	120	mA
C_i	Input capacitance			3		pF

 (1) All typical values are at $V_{CC} = 3.3 V$, $T_A = 25^\circ C$.

TIMING REQUIREMENTS

		MIN	NOM	MAX	UNIT
t_c	Input clock period	14.7	t_c	50	ns
t_w	High-level input clock pulse width duration	$0.4t_c$		$0.6t_c$	ns
t_t	Input signal transition time			5	ns
t_{su}	Data setup time, D0 through D27 before $CLKIN\uparrow$ or $CLKIN\downarrow$ (see Figure 2)	3			ns
t_h	Data hold time, D0 through D27 after $CLKIN\downarrow$ or $CLKIN\uparrow$ (see Figure 2)	1.5			ns

SWITCHING CHARACTERISTICS

over recommended operating conditions (unless otherwise noted)

PARAMETER	TEST CONDITIONS	MIN	TYP ⁽¹⁾	MAX	UNIT
t_0 Delay time, CLKOUT \uparrow to serial bit position 0	$t_c = 15.38 \text{ ns } (\pm 0.2\%),$ Input clock jitter < 50 ps ⁽²⁾ , See Figure 5	-0.20	0	0.20	ns
t_1 Delay time, CLKOUT \uparrow to serial bit position 1		$\frac{1}{7}t_c - 0.20$		$\frac{1}{7}t_c + 0.20$	ns
t_2 Delay time, CLKOUT \uparrow serial bit position 2		$\frac{2}{7}t_c - 0.20$		$\frac{2}{7}t_c + 0.20$	ns
t_3 Delay time, CLKOUT \uparrow serial bit position 3		$\frac{3}{7}t_c - 0.20$		$\frac{3}{7}t_c + 0.20$	ns
t_4 Delay time, CLKOUT \uparrow to serial bit position 4		$\frac{4}{7}t_c - 0.20$		$\frac{4}{7}t_c + 0.20$	ns
t_5 Delay time, CLKOUT \uparrow to serial bit position 5		$\frac{5}{7}t_c - 0.20$		$\frac{5}{7}t_c + 0.20$	ns
t_6 Delay time, CLKOUT \uparrow to serial bit position 6		$\frac{6}{7}t_c - 0.20$		$\frac{6}{7}t_c + 0.20$	ns
$t_{sk(o)}$ Output skew, $t_n - \frac{n}{7}t_c$			-0.20		0.20
t_7 Delay time, CLKIN \downarrow or CLKIN \uparrow to CLKOUT \uparrow	$t_c = 15.38 \text{ ns } (\pm 0.2\%),$ Input clock jitter < 50 ps ⁽²⁾ , See Figure 5		4.2		ns
$t_{c(o)}$ Output clock period			t_c		ps
$\Delta t_{c(o)}$ Output clock cycle-to-cycle jitter ⁽³⁾	$t_c = 15.38 \text{ ns } + 0.75\sin(2\pi 500E3t) \pm 0.05 \text{ ns},$ See Figure 6		± 80		ps
	$t_c = 15.38 \text{ ns } + 0.75\sin(2\pi 3E6t) \pm 0.05 \text{ ns},$ See Figure 6		± 300		ns
t_w High-level output clock pulse duration			$\frac{4}{7}t_c$		ps
t_t Differential output voltage transition time (t_r or t_f)	See Figure 3	260	700	1500	ps
t_{en} Enable time, $\overline{\text{SHTDN}}\uparrow$ to phase lock (Yn valid)	See Figure 7		1		ms
t_{dis} Disable time, $\overline{\text{SHTDN}}\downarrow$ to off-state (CLKOUT low)	See Figure 8		250		ns

 (1) All typical values are at $V_{CC} = 3.3 \text{ V}, T_A = 25^\circ\text{C}.$

(2) Input clock jitter is the magnitude of the change in the input clock period

(3) The output clock jitter is the change in the output clock period from one cycle to the next cycle observed over 15,000 cycles.

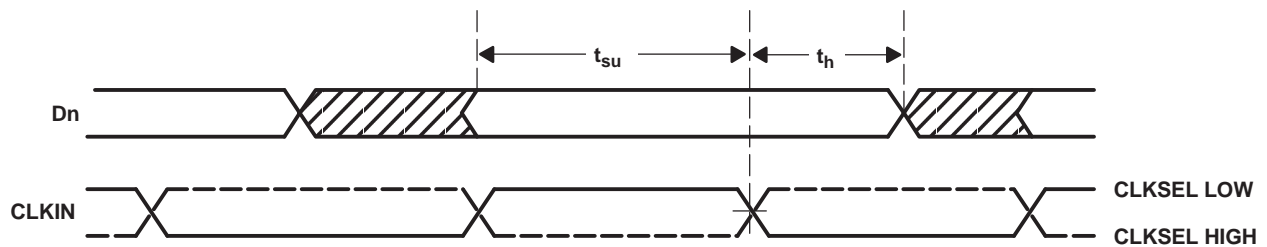
PARAMETER MEASUREMENT INFORMATION

note: All input timing is defined at 1.4 V on an input signal with a 10% to 90% rise or fall time of less than 5 ns.

Figure 2. Setup and Hold Time Definition

PARAMETER MEASUREMENT INFORMATION (continued)

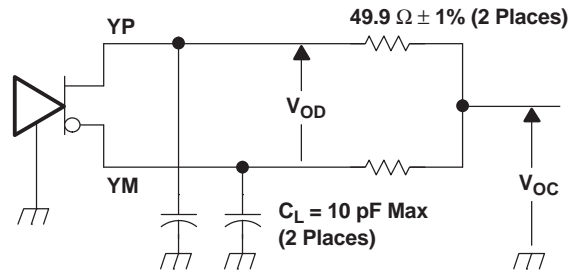

NOTE A: The lumped instrumentation capacitance for any single-ended voltage measurement is less than or equal to 10 pF. When making measurements at YP or YM, the complementary output is similarly loaded.

(a) SCHEMATIC

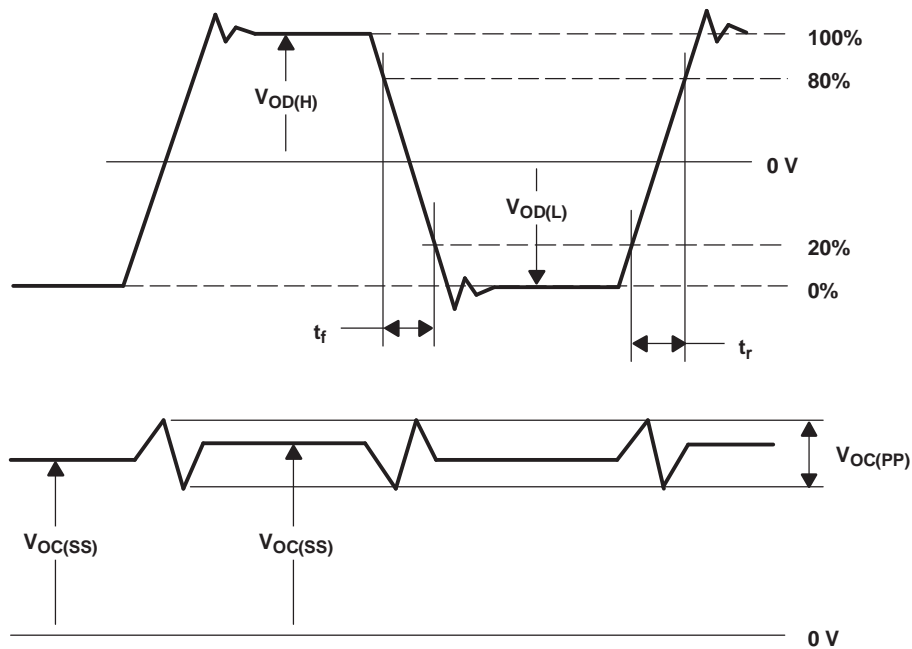

(b) WAVEFORMS

Figure 3. Test Load and Voltage Definitions for LVDS Outputs

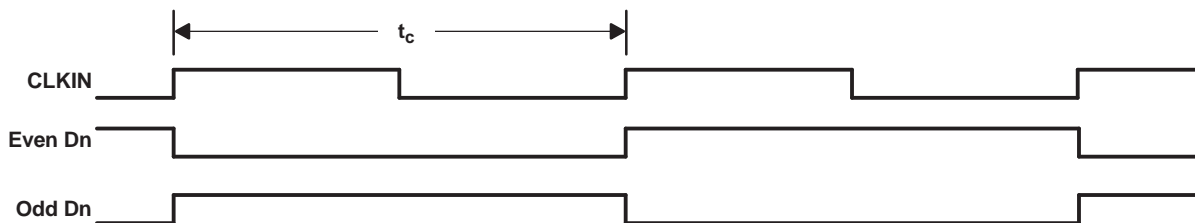

NOTE A: The worst-case test pattern produces nearly the maximum switching frequency for all of the LVDS outputs. Pattern with CLKSEL low shown.

Figure 4. Worst-Case Test Pattern (CLKSEL Low Shown)

PARAMETER MEASUREMENT INFORMATION (continued)

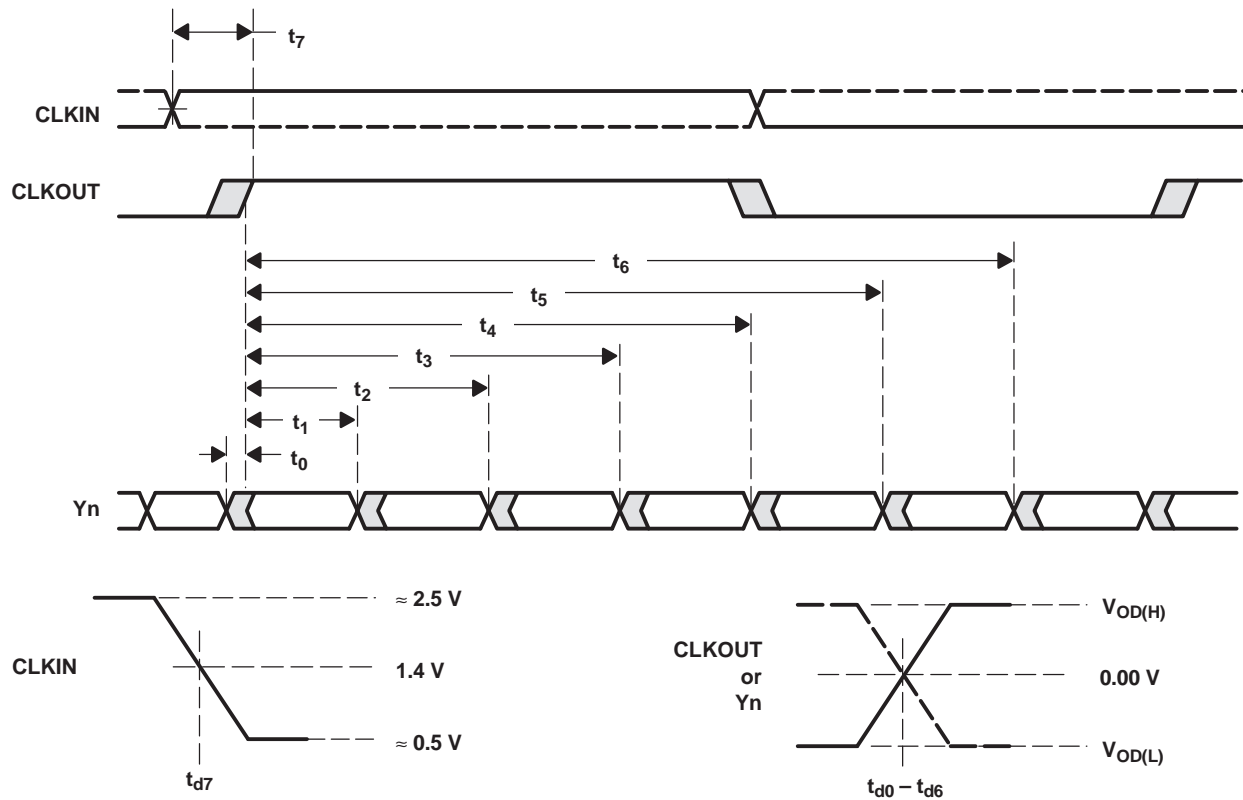

Figure 5. Timing Definitions

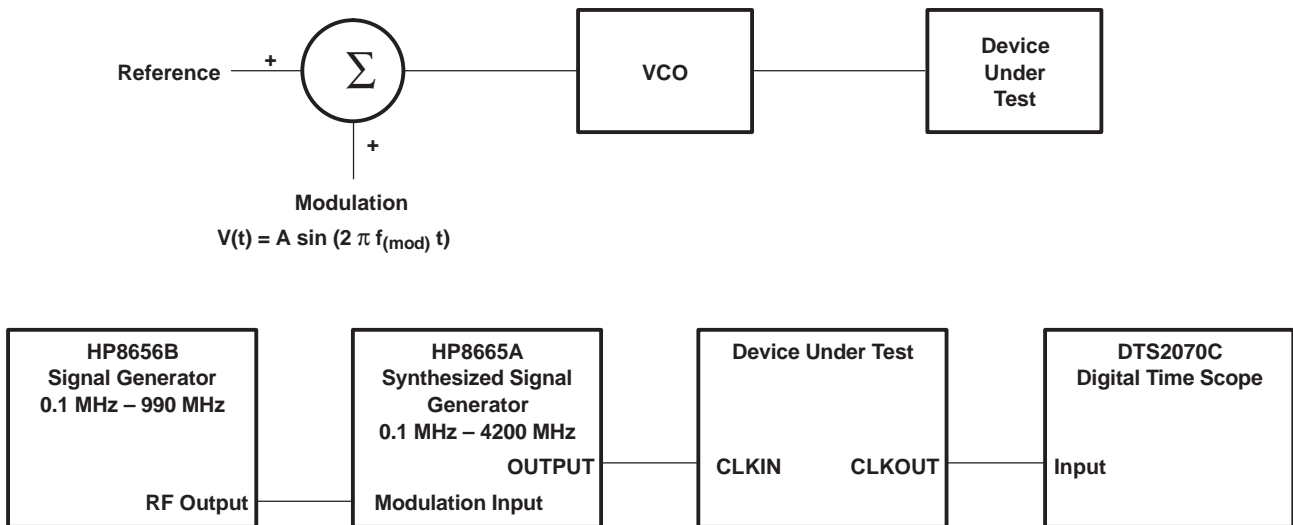

Figure 6. Output Clock Jitter Test Setup

PARAMETER MEASUREMENT INFORMATION (continued)

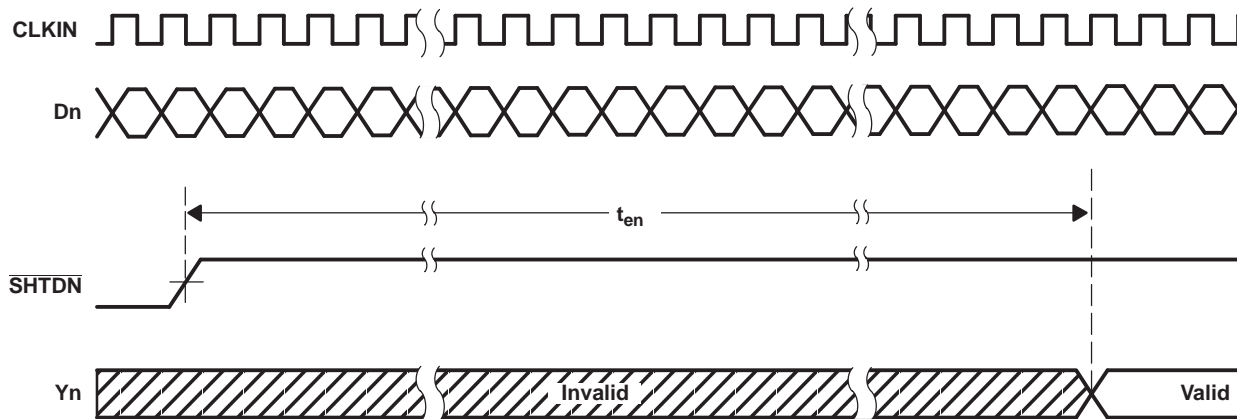

Figure 7. Enable Time Waveforms (CLKSEL low shown)

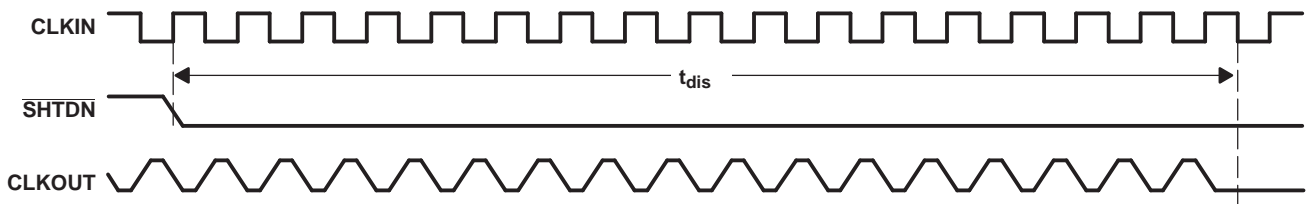

Figure 8. Disable Time Waveforms (CLKSEL low shown)

TYPICAL CHARACTERISTICS

WORST-CASE SUPPLY CURRENT
vs
FREQUENCY

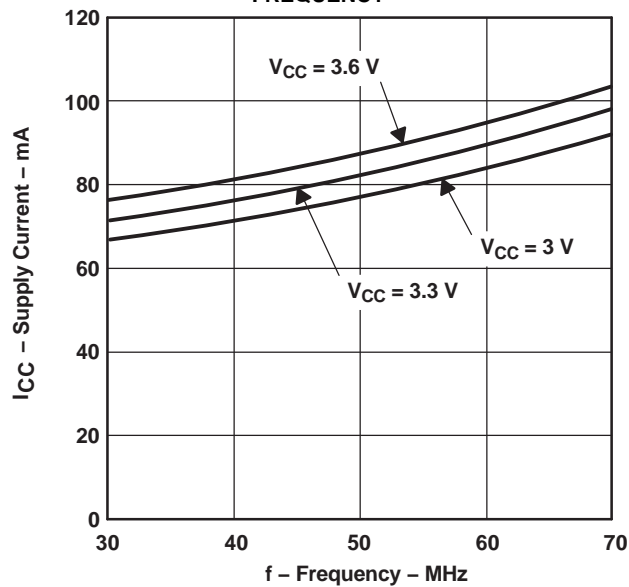

Figure 9.

APPLICATION INFORMATION

16-BIT BUS EXTENSION

In a 16-bit bus application (Figure 10), TTL data and clock coming from bus transceivers that interface the backplane bus arrive at the Tx parallel inputs of the LVDS serdes transmitter. The clock associated with the bus is also connected to the device. The on-chip PLL synchronizes this clock with the parallel data at the input. The data is then multiplexed into three different line drivers which perform the TTL to LVDS conversion. The clock is also converted to LVDS and presented to a separate driver. This synchronized LVDS data and clock at the receiver, which recovers the LVDS data and clock, performs a conversion back to TTL. Data is then demultiplexed into a parallel format. An on-chip PLL synchronizes the received clock with the parallel data, and then all are presented to the parallel output port of the receiver.

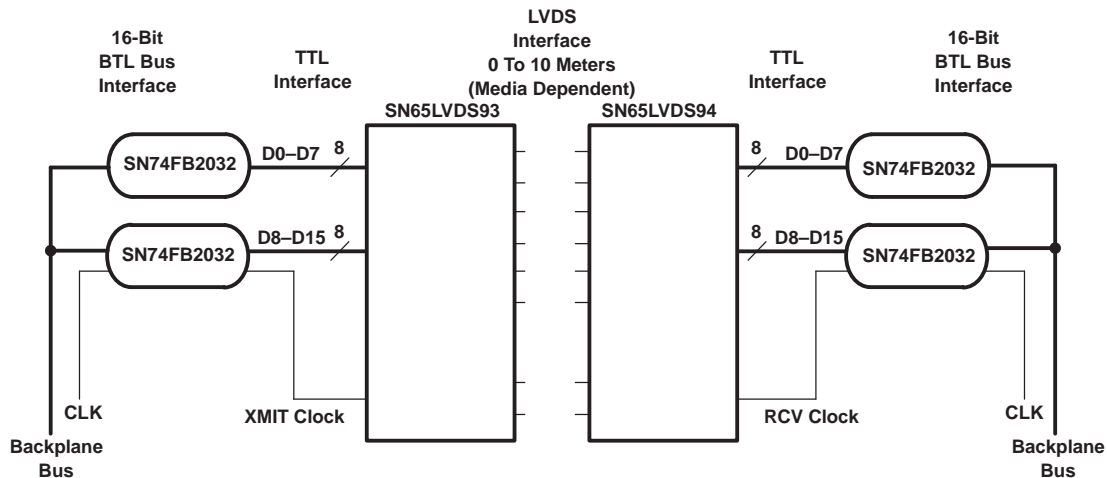

Figure 10. 16-Bit Bus Extension

16-BIT BUS EXTENSION WITH PARITY

In the previous application we did not have a checking bit that would provide assurance that the data crosses the link. If we add a parity bit to the previous example, we would have a diagram similar to the one in Figure 11. The device following the SN74FB2032 is a low-cost parity generator. Each transmit-side transceiver/parity generator takes the LVTTTL data from the corresponding transceiver, performs a parity calculation over the byte, and then passes the bits with its calculated parity value on the parallel input of the LVDS serdes transmitter. Again, the on-chip PLL synchronizes this transmit clock with the eighteen parallel bits (16 data + 2 parity) at the input. The synchronized LVDS data/parity and clock arrive at the receiver.

The receiver performs the conversion from LVDS to LVTTTL and the transceiver/parity generator performs the parity calculations. These devices compare their corresponding input bytes with the value received on the parity bit. The transceiver/parity generator will assert its parity error output if a mismatch is detected.

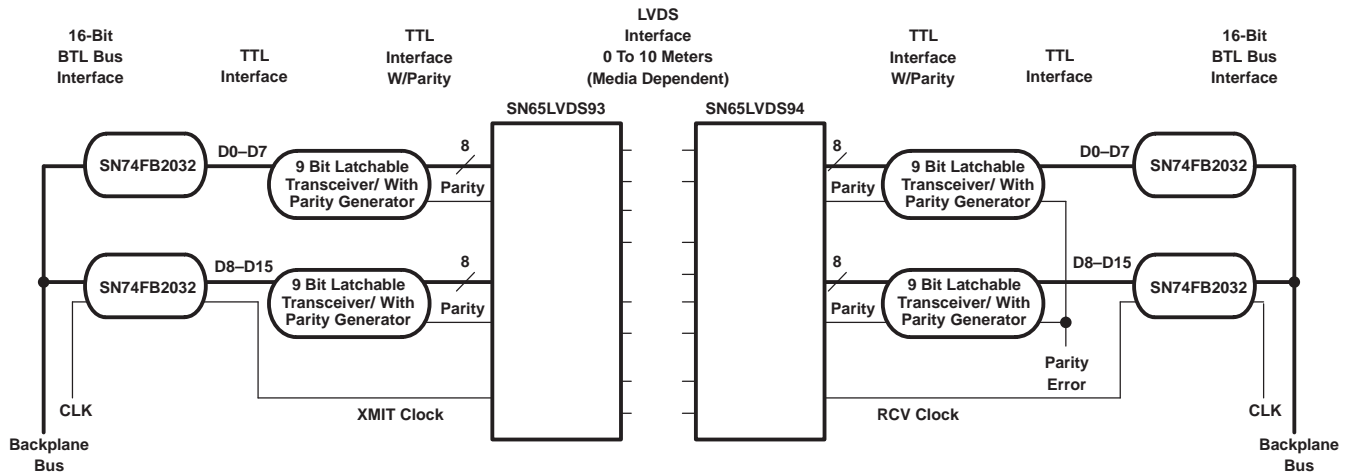

Figure 11. 16-Bit Bus Extension With Parity

low cost virtual backplane transceiver

Figure 12 represents LVDS serdes in an application as a virtual backplane transceiver (VBT). The concept of a VBT can be achieved by implementing individual LVDS serdes chipsets in both directions of subsystem serialized links.

Depending on the application, the designer will face varying choices when implementing a VBT. In addition to the devices shown in Figure 12, functions such as parity and delay lines for control signals could be included. Using additional circuitry, half-duplex or full-duplex operation can be achieved by configuring the clock and control lines properly.

The designer may choose to implement an independent clock oscillator at each end of the link and then use a PLL to synchronize LVDS serdes's parallel I/O to the backplane bus. Resynchronizing FIFOs may also be required.

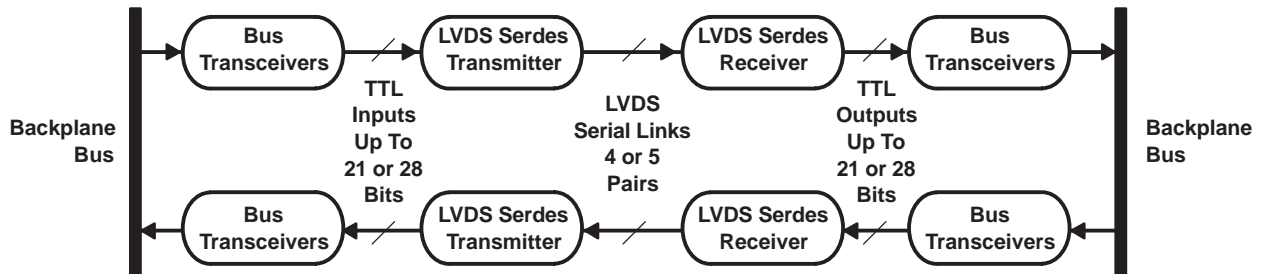

Figure 12. Virtual Backplane Transceiver

PACKAGING INFORMATION

Orderable Device	Status (1)	Package Type	Package Drawing	Pins	Package Qty	Eco Plan (2)	Lead/Ball Finish	MSL Peak Temp (3)	Op Temp (°C)	Top-Side Markings (4)	Samples
SN65LVDS93DGG	ACTIVE	TSSOP	DGG	56	35	Green (RoHS & no Sb/Br)	CU NIPDAU	Level-2-260C-1 YEAR		SN65LVDS93	Samples
SN65LVDS93DGGG4	ACTIVE	TSSOP	DGG	56	35	Green (RoHS & no Sb/Br)	CU NIPDAU	Level-2-260C-1 YEAR		SN65LVDS93	Samples
SN65LVDS93DGGR	ACTIVE	TSSOP	DGG	56	2000	Green (RoHS & no Sb/Br)	CU NIPDAU	Level-2-260C-1 YEAR	-40 to 85	SN65LVDS93	Samples
SN65LVDS93DGGRG4	ACTIVE	TSSOP	DGG	56	2000	Green (RoHS & no Sb/Br)	CU NIPDAU	Level-2-260C-1 YEAR	-40 to 85	SN65LVDS93	Samples

(1) The marketing status values are defined as follows:

ACTIVE: Product device recommended for new designs.

LIFEBUY: TI has announced that the device will be discontinued, and a lifetime-buy period is in effect.

NRND: Not recommended for new designs. Device is in production to support existing customers, but TI does not recommend using this part in a new design.

PREVIEW: Device has been announced but is not in production. Samples may or may not be available.

OBSOLETE: TI has discontinued the production of the device.

(2) Eco Plan - The planned eco-friendly classification: Pb-Free (RoHS), Pb-Free (RoHS Exempt), or Green (RoHS & no Sb/Br) - please check <http://www.ti.com/productcontent> for the latest availability information and additional product content details.

TBD: The Pb-Free/Green conversion plan has not been defined.

Pb-Free (RoHS): TI's terms "Lead-Free" or "Pb-Free" mean semiconductor products that are compatible with the current RoHS requirements for all 6 substances, including the requirement that lead not exceed 0.1% by weight in homogeneous materials. Where designed to be soldered at high temperatures, TI Pb-Free products are suitable for use in specified lead-free processes.

Pb-Free (RoHS Exempt): This component has a RoHS exemption for either 1) lead-based flip-chip solder bumps used between the die and package, or 2) lead-based die adhesive used between the die and leadframe. The component is otherwise considered Pb-Free (RoHS compatible) as defined above.

Green (RoHS & no Sb/Br): TI defines "Green" to mean Pb-Free (RoHS compatible), and free of Bromine (Br) and Antimony (Sb) based flame retardants (Br or Sb do not exceed 0.1% by weight in homogeneous material)

(3) MSL, Peak Temp. -- The Moisture Sensitivity Level rating according to the JEDEC industry standard classifications, and peak solder temperature.

(4) Multiple Top-Side Markings will be inside parentheses. Only one Top-Side Marking contained in parentheses and separated by a "~" will appear on a device. If a line is indented then it is a continuation of the previous line and the two combined represent the entire Top-Side Marking for that device.

Important Information and Disclaimer: The information provided on this page represents TI's knowledge and belief as of the date that it is provided. TI bases its knowledge and belief on information provided by third parties, and makes no representation or warranty as to the accuracy of such information. Efforts are underway to better integrate information from third parties. TI has taken and continues to take reasonable steps to provide representative and accurate information but may not have conducted destructive testing or chemical analysis on incoming materials and chemicals. TI and TI suppliers consider certain information to be proprietary, and thus CAS numbers and other limited information may not be available for release.

In no event shall TI's liability arising out of such information exceed the total purchase price of the TI part(s) at issue in this document sold by TI to Customer on an annual basis.

TAPE AND REEL INFORMATION



QUADRANT ASSIGNMENTS FOR PIN 1 ORIENTATION IN TAPE



*All dimensions are nominal

Device	Package Type	Package Drawing	Pins	SPQ	Reel Diameter (mm)	Reel Width W1 (mm)	A0 (mm)	B0 (mm)	K0 (mm)	P1 (mm)	W (mm)	Pin1 Quadrant
SN65LVDS93DGGR	TSSOP	DGG	56	2000	330.0	24.4	8.6	15.6	1.8	12.0	24.0	Q1

TAPE AND REEL BOX DIMENSIONS



*All dimensions are nominal

Device	Package Type	Package Drawing	Pins	SPQ	Length (mm)	Width (mm)	Height (mm)
SN65LVDS93DGGR	TSSOP	DGG	56	2000	350.0	350.0	43.0

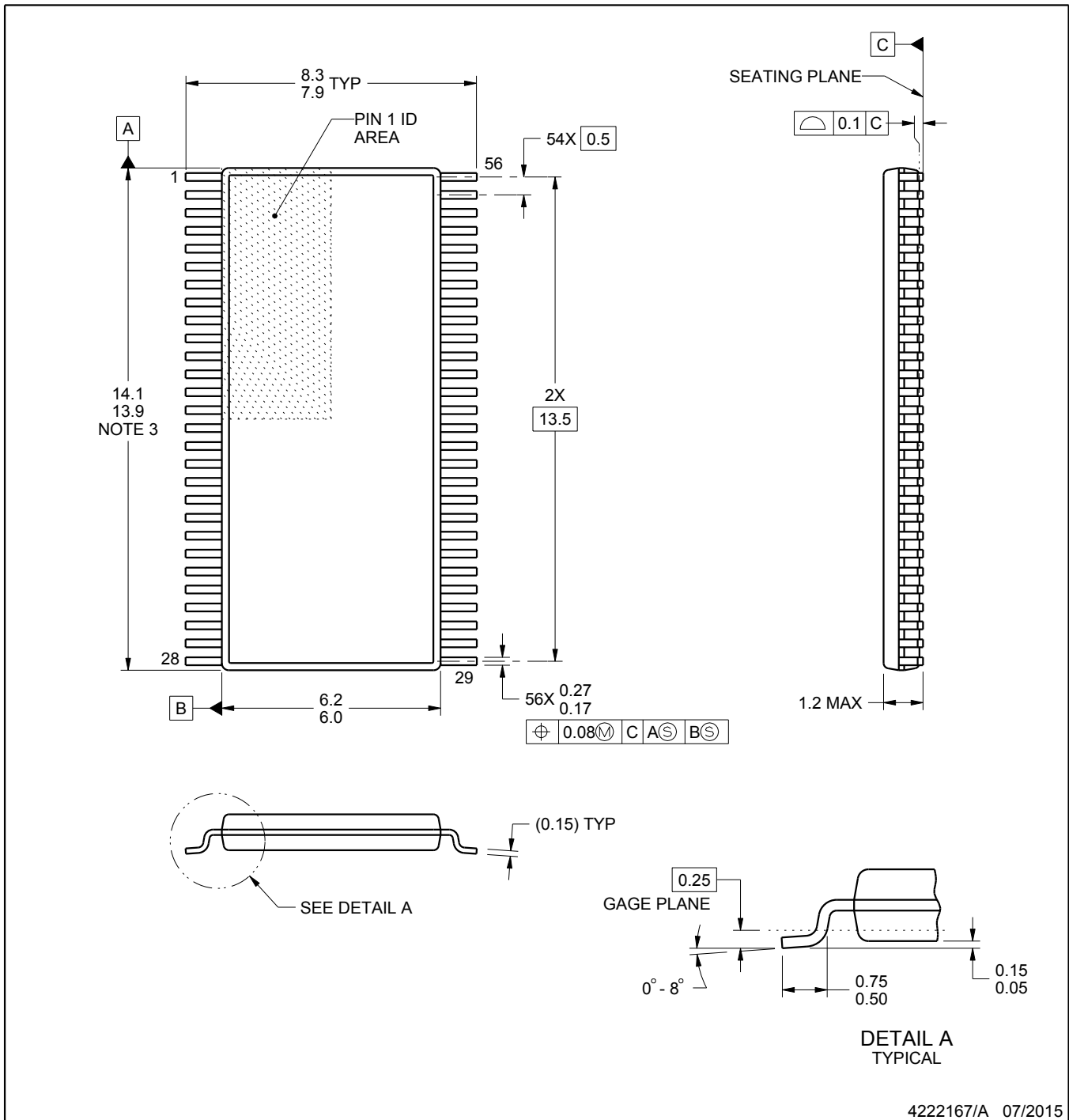

4222167/A 07/2015

NOTES:

1. All linear dimensions are in millimeters. Any dimensions in parenthesis are for reference only. Dimensioning and tolerancing per ASME Y14.5M.
2. This drawing is subject to change without notice.
3. This dimension does not include mold flash, protrusions, or gate burrs. Mold flash, protrusions, or gate burrs shall not exceed 0.15 mm per side.
4. Reference JEDEC registration MO-153.

EXAMPLE BOARD LAYOUT

DGG0056A

TSSOP - 1.2 mm max height

SMALL OUTLINE PACKAGE

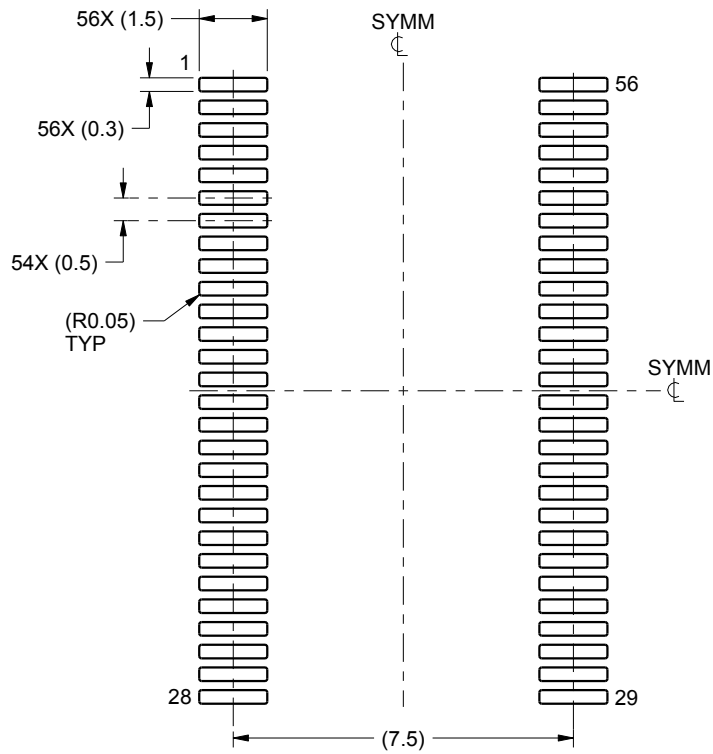

LAND PATTERN EXAMPLE
SCALE:6X

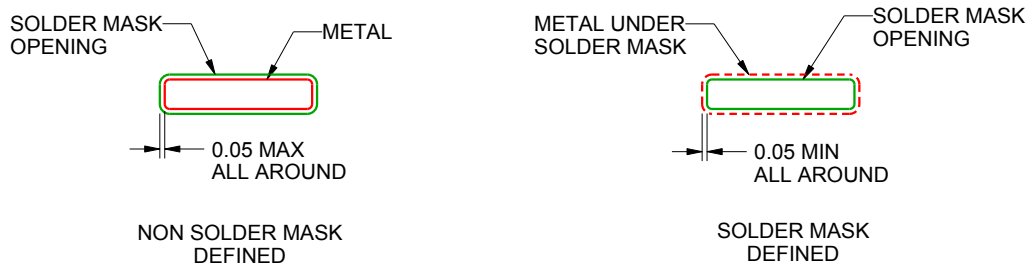

SOLDER MASK DETAILS

4222167/A 07/2015

NOTES: (continued)

- 5. Publication IPC-7351 may have alternate designs.
- 6. Solder mask tolerances between and around signal pads can vary based on board fabrication site.

EXAMPLE STENCIL DESIGN

DGG0056A

TSSOP - 1.2 mm max height

SMALL OUTLINE PACKAGE

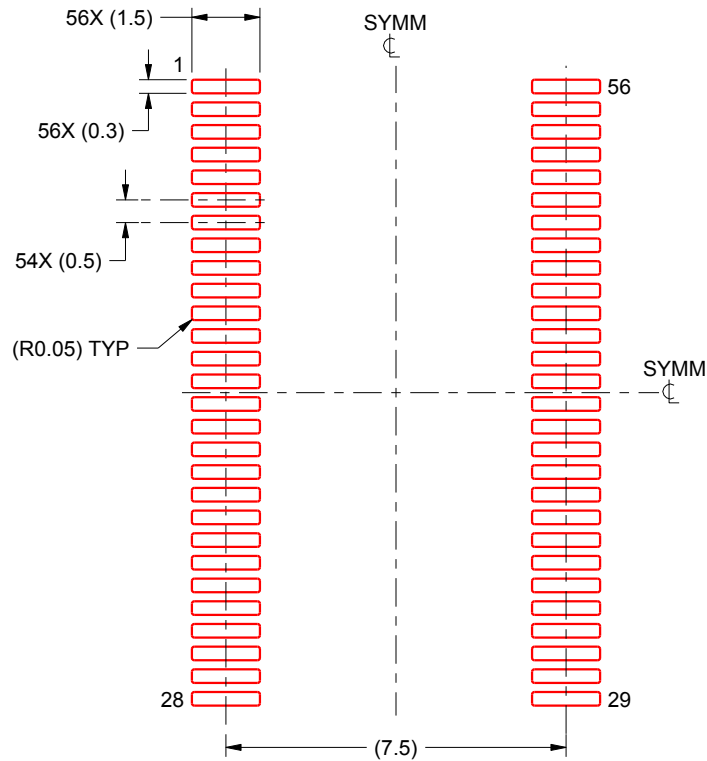

SOLDER PASTE EXAMPLE
BASED ON 0.125 mm THICK STENCIL
SCALE:6X

4222167/A 07/2015

NOTES: (continued)

7. Laser cutting apertures with trapezoidal walls and rounded corners may offer better paste release. IPC-7525 may have alternate design recommendations.
8. Board assembly site may have different recommendations for stencil design.

IMPORTANT NOTICE AND DISCLAIMER

TI PROVIDES TECHNICAL AND RELIABILITY DATA (INCLUDING DATASHEETS), DESIGN RESOURCES (INCLUDING REFERENCE DESIGNS), APPLICATION OR OTHER DESIGN ADVICE, WEB TOOLS, SAFETY INFORMATION, AND OTHER RESOURCES "AS IS" AND WITH ALL FAULTS, AND DISCLAIMS ALL WARRANTIES, EXPRESS AND IMPLIED, INCLUDING WITHOUT LIMITATION ANY IMPLIED WARRANTIES OF MERCHANTABILITY, FITNESS FOR A PARTICULAR PURPOSE OR NON-INFRINGEMENT OF THIRD PARTY INTELLECTUAL PROPERTY RIGHTS.

These resources are intended for skilled developers designing with TI products. You are solely responsible for (1) selecting the appropriate TI products for your application, (2) designing, validating and testing your application, and (3) ensuring your application meets applicable standards, and any other safety, security, or other requirements. These resources are subject to change without notice. TI grants you permission to use these resources only for development of an application that uses the TI products described in the resource. Other reproduction and display of these resources is prohibited. No license is granted to any other TI intellectual property right or to any third party intellectual property right. TI disclaims responsibility for, and you will fully indemnify TI and its representatives against, any claims, damages, costs, losses, and liabilities arising out of your use of these resources.

TI's products are provided subject to TI's Terms of Sale (www.ti.com/legal/termsofsale.html) or other applicable terms available either on ti.com or provided in conjunction with such TI products. TI's provision of these resources does not expand or otherwise alter TI's applicable warranties or warranty disclaimers for TI products.

Mailing Address: Texas Instruments, Post Office Box 655303, Dallas, Texas 75265
Copyright © 2019, Texas Instruments Incorporated

Looking for pricing, stock, or lifecycle information?

Click below to explore more details on WIN SOURCE:

 [View SN65LVDS93DGG on WIN SOURCE](#)

 [Texas Instruments](#) Information

Optimize Your Supply Chain with WIN SOURCE Solutions

-  Global Sourcing Solution
-  Obsolete Management
-  Cost Control Management
-  Shortage Management
-  Alternative Solution
-  Excess Inventory Management