



**THE DATASHEET OF
SN65LVDM31DR**



HIGH-SPEED DIFFERENTIAL LINE DRIVER

FEATURES

- **Designed for Signaling Rates**

NOTE: The signaling rate is the number of voltage transitions that can be made per second.

Up to 150 Mbps

- **Low-Voltage Differential Signaling With Typical Output Voltage of 700 mV and a 100-Ω Load**
- **Propagation Delay Time of 2.3 ns, Typical**
- **Single 3.3-V Supply Operation**
- **One Driver's Power Dissipation at 75 MHz, 50 mW, Typical**
- **High-Impedance Outputs When Disabled or With $V_{CC} < 1.5$ V**
- **Bus-Pin ESD Protection Exceeds 12 kV**
- **Low-Voltage CMOS (LVCMOS) Logic Input Levels Are 5-V Tolerant**

DESCRIPTION

The SN65LVDM31 incorporates four differential line drivers that implement the electrical characteristics of low-voltage differential signaling. This product offers a low-power alternative to 5-V PECL drivers with similar signal levels. Any of the four current-mode drivers will deliver a minimum differential output voltage magnitude of 540 mV into a 100-Ω load when enabled by either an active-low or active-high enable input.

The intended application of this device and signaling technique is for both point-to-point and multiplexed baseband data transmission over controlled impedance media of approximately 100 Ω. The transmission media may be printed-circuit board traces, backplanes, or cables. The ultimate rate and distance of data transfer is dependent upon the attenuation characteristics of the media and the noise coupling to the environment.

The SN65LVDM31 is characterized for operation from -40°C to 85°C.

SN65LVDM31D (Marked as LVDM31)
(TOP VIEW)

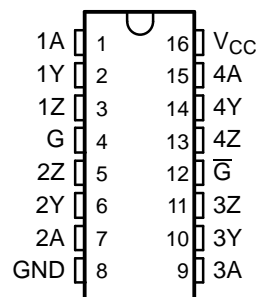

FUNCTIONAL BLOCK DIAGRAM

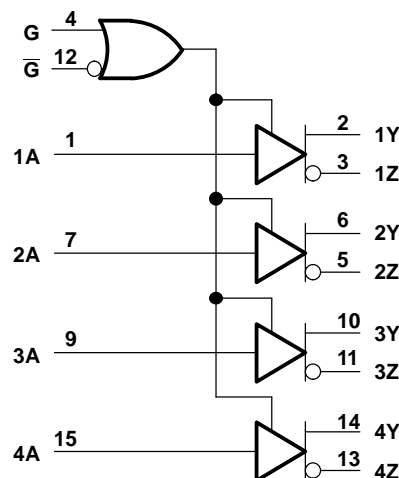

FUNCTION TABLE

INPUT	ENABLES		OUTPUTS	
A	G	\bar{G}	Y	Z
H	H	X	H	L
L	H	X	L	H
H	X	L	H	L
L	X	L	L	H
X	L	H	Z	Z
Open	H	X	L	H
Open	X	L	L	H



Please be aware that an important notice concerning availability, standard warranty, and use in critical applications of Texas Instruments semiconductor products and disclaimers thereto appears at the end of this data sheet.



These devices have limited built-in ESD protection. The leads should be shorted together or the device placed in conductive foam during storage or handling to prevent electrostatic damage to the MOS gates.

EQUIVALENT INPUT AND OUTPUT SCHEMATIC DIAGRAMS

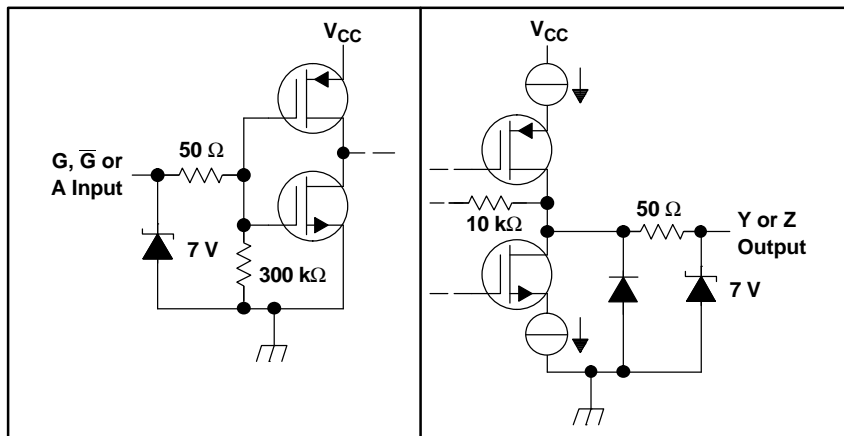

ABSOLUTE MAXIMUM RATINGS

over operating free-air temperature range (unless otherwise noted)⁽¹⁾

		UNIT
Supply voltage range V_{CC} ⁽²⁾		-0.5 V to 4 V
Input voltage range	Inputs	-0.5 V to 6 V
	Y or Z	-0.5 V to 4 V
Electrostatic discharge ⁽³⁾ : Y, Z, and GND		Class 3, A:12 kV, B:600 V
Continuous power dissipation		See Dissipation Rating Table
Storage temperature range		-65°C to 150°C
Lead temperature 1,6 mm (1/16 inch) from case for 10 seconds		260°C

- (1) Stresses beyond those listed under *absolute maximum ratings* may cause permanent damage to the device. These are stress ratings only, and functional operation of the device at these or any other conditions beyond those indicated under *recommended operating conditions* is not implied. Exposure to absolute-maximum-rated conditions for extended periods may affect device reliability.
- (2) All voltage values, except differential I/O bus voltages, are with respect to network ground terminal.
- (3) Tested in accordance with MIL-STD-883C Method 3015.7.

DISSIPATION RATING TABLE

PACKAGE	$T_A \leq 25^\circ\text{C}$ POWER RATING	OPERATING FACTOR ⁽¹⁾ ABOVE $T_A = 25^\circ\text{C}$	$T_A = 85^\circ\text{C}$ POWER RATING
D	950 mW	7.6 mW/°C	494 mW

- (1) This is the inverse of the junction-to-ambient thermal resistance when board-mounted and with no air flow.

RECOMMENDED OPERATING CONDITIONS

		MIN	NOM	MAX	UNIT
V_{CC}	Supply voltage	3	3.3	3.6	V
V_{IH}	High-level input voltage	2.0			V
V_{IL}	Low-level input voltage			0.8	V
T_A	Operating free-air temperature	40		85	°C

ELECTRICAL CHARACTERISTICS

over recommended operating conditions (unless otherwise noted)

PARAMETER		TEST CONDITIONS		MIN	TYP ⁽¹⁾	MAX	UNIT
V _{OD}	Differential output voltage magnitude	R _L = 100 Ω,	See Figure 2	540	700	860	mV
		R _L = 50 Ω,	See Figure 2	270	350	430	
Δ V _{OD}	Change in differential output voltage magnitude between logic states	See Figure 2		-25	0	25	mV
V _{OC(SS)}	Steady-state common-mode output voltage	See Figure 3		1.14	1.2	1.3	V
ΔV _{OC(SS)}	Change in steady-state common-mode output voltage between logic states			-30	0	30	mV
V _{OC(PP)}	Peak-to-peak common-mode output voltage			70	100		
I _{CC}	Supply current	Enabled, No load	V _{IN} = 0 or V _{CC}	6	10	mA	
		Enabled, R _L = 100 Ω		35	40		
		Disabled		0.5	0.7		
I _{IH}	High-level input current	V _{IH} = 3 V		-10	3	10	μA
I _{IL}	Low-level input current	V _{IL} = 0 V		-10	0	10	μA
I _{OS}	Short-circuit output current	V _{OY} or V _{OZ} = 0 V		7	10	mA	
		V _{OD} = 0 V		7	10		
I _{OZ}	High-impedance state output current	V _O = 0 V or V _{CC}				±1	μA
I _{O(OFF)}	Power-off output current	V _{CC} = 1.5 V,	V _O = 3.6 V			±1	μA

(1) All typical values are at 25°C and with a 3.3-V supply.

SWITCHING CHARACTERISTICS

over recommended operating conditions (unless otherwise noted)

PARAMETER		TEST CONDITIONS		MIN	TYP	MAX	UNIT	
t _{PLH}	Propagation delay time, low-to-high-level output	See Figure 4		1.8	2.3	2.9	ns	
t _{PHL}	Propagation delay time, high-to-low-level output			1.8	2.3	2.9	ns	
t _r	Differential output signal rise time			0.4	0.6	1.0	ns	
t _f	Differential output signal fall time			0.4	0.6	1.0	ns	
t _{sk(p)}	Pulse skew (t _{PHL} - t _{PLH})					50	350	ps
t _{sk(o)}	Channel-to-channel output skew ⁽¹⁾							200
t _{sk(pp)}	Part-to-part skew ⁽²⁾					1	ns	
t _{PZH}	Propagation delay time, high-impedance-to-high-level output	See Figure 5		6	15	ns		
t _{PZL}	Propagation delay time, high-impedance-to-low level output			6	15	ns		
t _{PHz}	Propagation delay time, high-level-to-high-impedance output			6	15	ns		
t _{PLz}	Propagation delay time, low-level-to-high-impedance output			6	15	ns		

(1) t_{sk(o)} is the maximum delay time difference between drivers on the same device.

(2) t_{sk(pp)} is the magnitude of the difference in propagation delay times between any specified terminals of two devices when both devices operate with the same supply voltages, at the same temperature, and have identical packages and test circuits.

PARAMETER MEASUREMENT INFORMATION

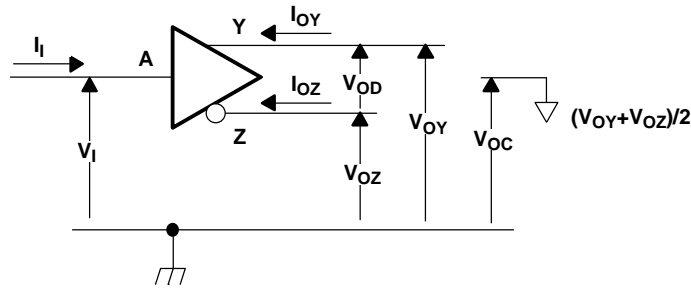

Figure 1. Driver Voltage and Current Definitions

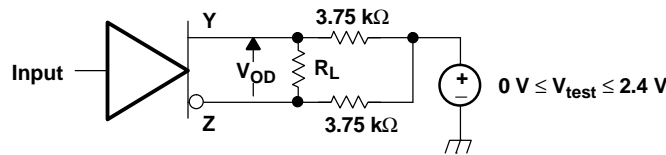
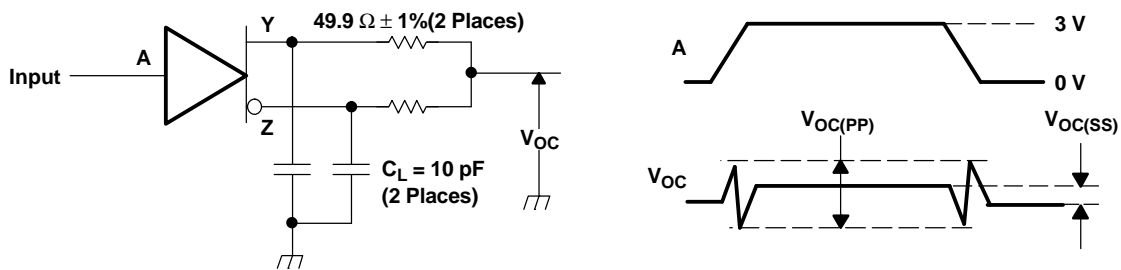
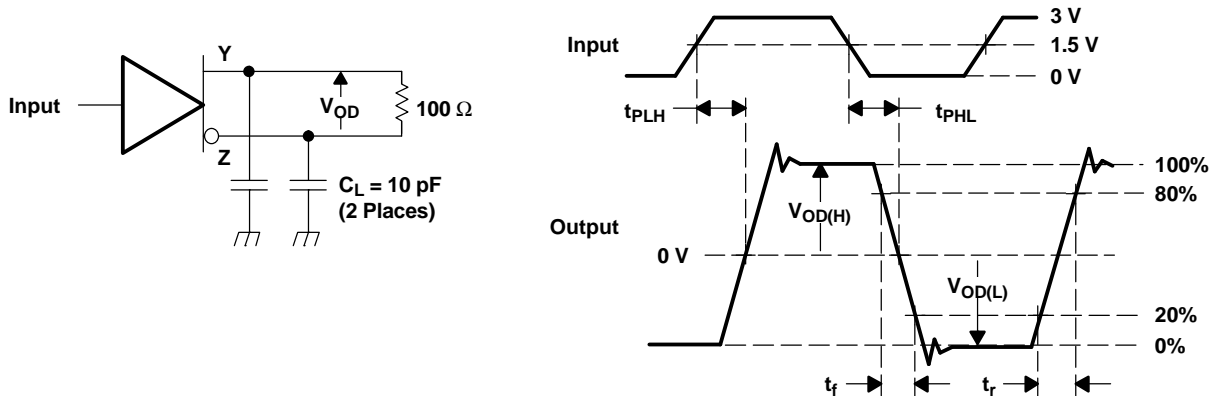

Figure 2. V_{OD} Test Circuit



NOTE: All input pulses are supplied by a generator having the following characteristics: t_r or $t_f \leq 1$ ns, pulse repetition rate (PRR) = 0.5 Mpps, pulse width = 500 ± 10 ns. C_L includes instrumentation and fixture capacitance within 0,06 mm of the DUT. The measurement of $V_{OC(PP)}$ is made on test equipment with a -3 dB bandwidth of at least 300 MHz.

Figure 3. Test Circuit and Definitions for the Driver Common-Mode Output Voltage



NOTE: All input pulses are supplied by a generator having the following characteristics: t_r or $t_f \leq 1$ ns, pulse repetition rate (PRR) = 50 Mpps, pulse width = 10 ± 0.2 ns. C_L includes instrumentation and fixture capacitance within 0,06 mm of the DUT.

Figure 4. Test Circuit, Timing, and Voltage Definitions for the Differential Output Signal

PARAMETER MEASUREMENT INFORMATION (continued)

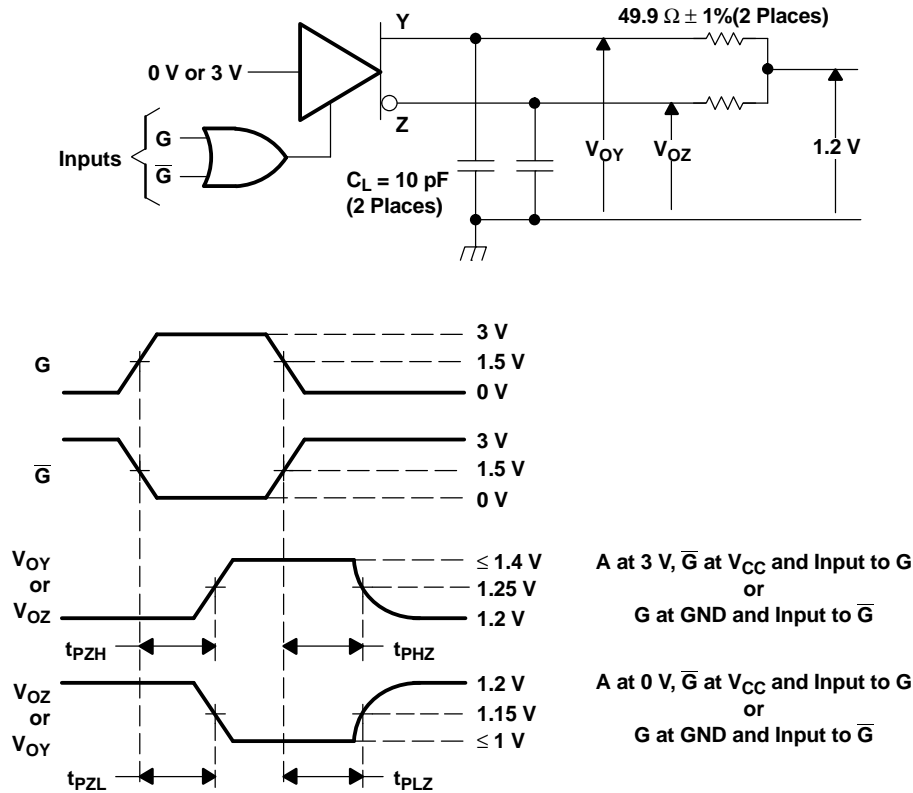

NOTE: All input pulses are supplied by a generator having the following characteristics: t_r or $t_f \leq 1$ ns, pulse repetition rate (PRR) = 0.5 Mpps, pulse width = 500 ± 10 ns. C_L includes instrumentation and fixture capacitance within 0,06 mm of the DUT.

Figure 5. Enable and Disable Time Circuit and Definitions

TYPICAL CHARACTERISTICS

SUPPLY CURRENT
vs
FREQUENCY

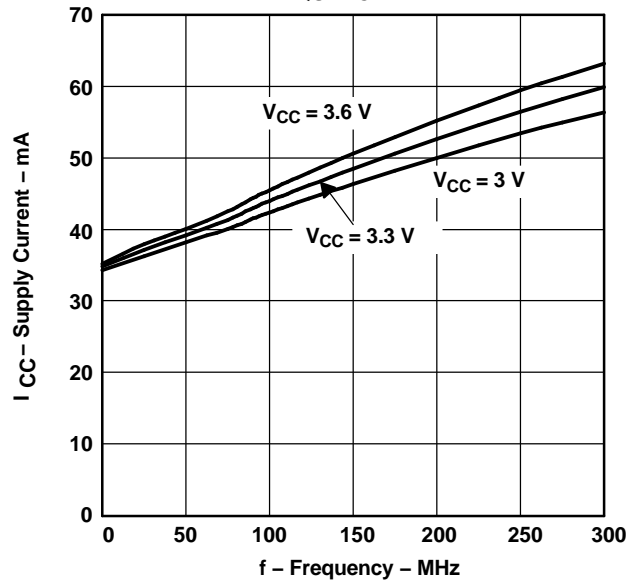

Figure 6.

LOW-LEVEL OUTPUT VOLTAGE
vs
LOW-LEVEL OUTPUT CURRENT

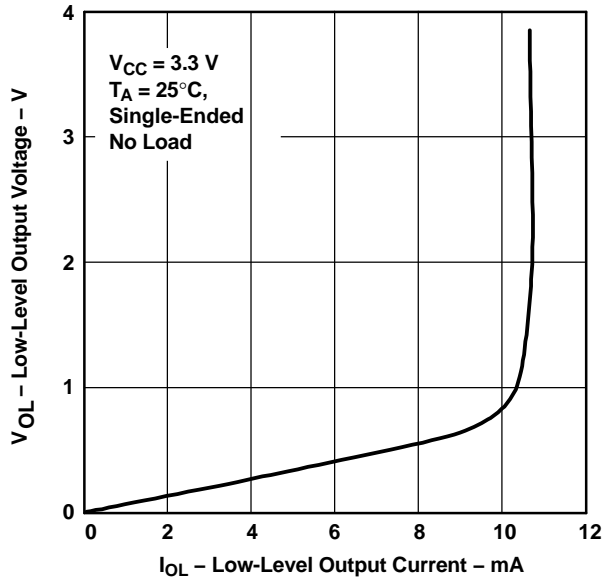

Figure 7.

HIGH-LEVEL OUTPUT VOLTAGE
vs
HIGH-LEVEL OUTPUT CURRENT

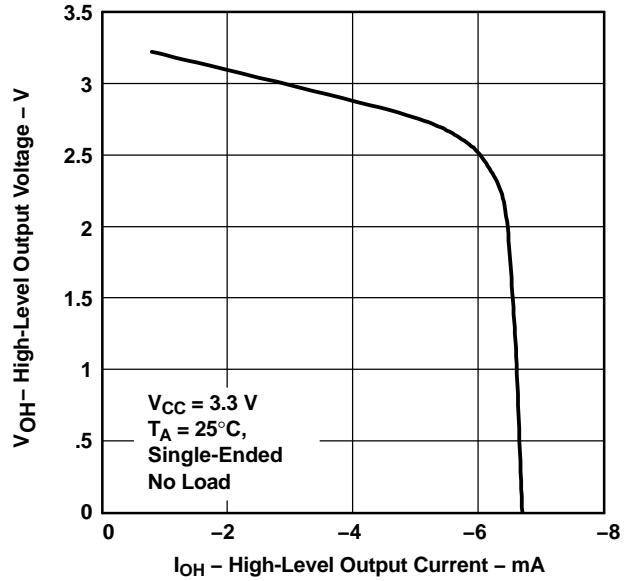
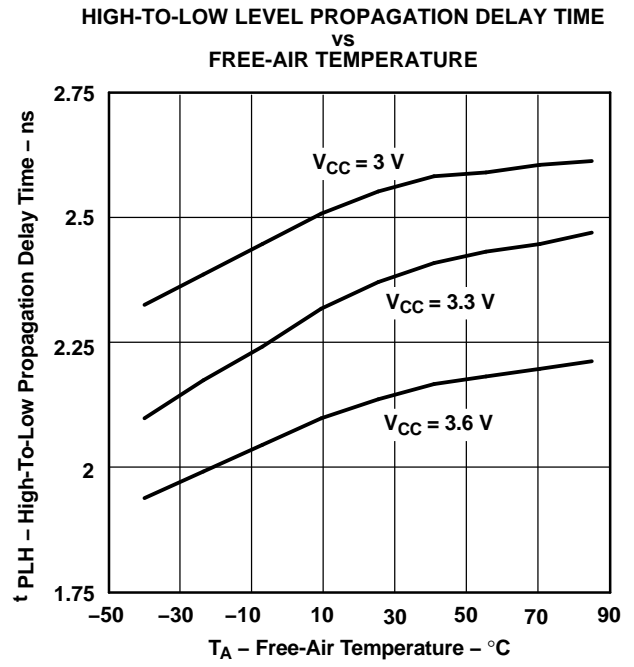
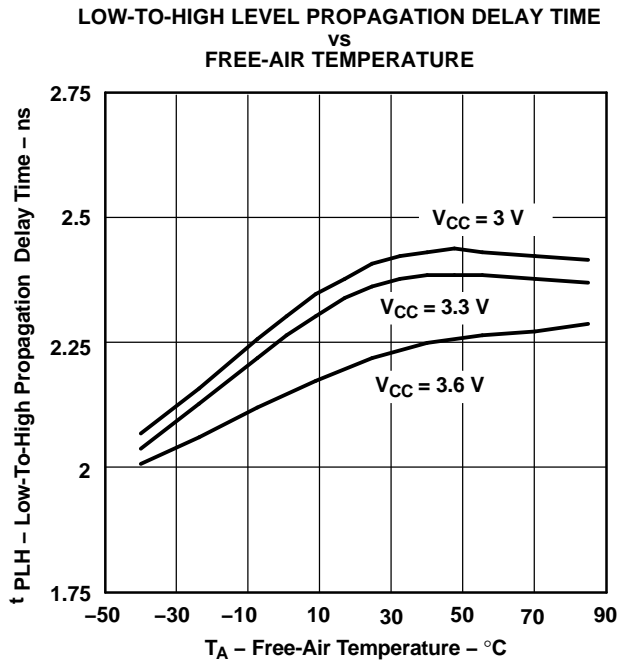

Figure 8.

TYPICAL CHARACTERISTICS (continued)



IMPORTANT NOTICE

Texas Instruments Incorporated and its subsidiaries (TI) reserve the right to make corrections, modifications, enhancements, improvements, and other changes to its products and services at any time and to discontinue any product or service without notice. Customers should obtain the latest relevant information before placing orders and should verify that such information is current and complete. All products are sold subject to TI's terms and conditions of sale supplied at the time of order acknowledgment.

TI warrants performance of its hardware products to the specifications applicable at the time of sale in accordance with TI's standard warranty. Testing and other quality control techniques are used to the extent TI deems necessary to support this warranty. Except where mandated by government requirements, testing of all parameters of each product is not necessarily performed.

TI assumes no liability for applications assistance or customer product design. Customers are responsible for their products and applications using TI components. To minimize the risks associated with customer products and applications, customers should provide adequate design and operating safeguards.

TI does not warrant or represent that any license, either express or implied, is granted under any TI patent right, copyright, mask work right, or other TI intellectual property right relating to any combination, machine, or process in which TI products or services are used. Information published by TI regarding third-party products or services does not constitute a license from TI to use such products or services or a warranty or endorsement thereof. Use of such information may require a license from a third party under the patents or other intellectual property of the third party, or a license from TI under the patents or other intellectual property of TI.

Reproduction of TI information in TI data books or data sheets is permissible only if reproduction is without alteration and is accompanied by all associated warranties, conditions, limitations, and notices. Reproduction of this information with alteration is an unfair and deceptive business practice. TI is not responsible or liable for such altered documentation. Information of third parties may be subject to additional restrictions.

Resale of TI products or services with statements different from or beyond the parameters stated by TI for that product or service voids all express and any implied warranties for the associated TI product or service and is an unfair and deceptive business practice. TI is not responsible or liable for any such statements.

TI products are not authorized for use in safety-critical applications (such as life support) where a failure of the TI product would reasonably be expected to cause severe personal injury or death, unless officers of the parties have executed an agreement specifically governing such use. Buyers represent that they have all necessary expertise in the safety and regulatory ramifications of their applications, and acknowledge and agree that they are solely responsible for all legal, regulatory and safety-related requirements concerning their products and any use of TI products in such safety-critical applications, notwithstanding any applications-related information or support that may be provided by TI. Further, Buyers must fully indemnify TI and its representatives against any damages arising out of the use of TI products in such safety-critical applications.

TI products are neither designed nor intended for use in military/aerospace applications or environments unless the TI products are specifically designated by TI as military-grade or "enhanced plastic." Only products designated by TI as military-grade meet military specifications. Buyers acknowledge and agree that any such use of TI products which TI has not designated as military-grade is solely at the Buyer's risk, and that they are solely responsible for compliance with all legal and regulatory requirements in connection with such use.

TI products are neither designed nor intended for use in automotive applications or environments unless the specific TI products are designated by TI as compliant with ISO/TS 16949 requirements. Buyers acknowledge and agree that, if they use any non-designated products in automotive applications, TI will not be responsible for any failure to meet such requirements.

Following are URLs where you can obtain information on other Texas Instruments products and application solutions:

Products

Amplifiers	amplifier.ti.com
Data Converters	dataconverter.ti.com
DSP	dsp.ti.com
Clocks and Timers	www.ti.com/clocks
Interface	interface.ti.com
Logic	logic.ti.com
Power Mgmt	power.ti.com
Microcontrollers	microcontroller.ti.com
RFID	www.ti-rfid.com
RF/IF and ZigBee® Solutions	www.ti.com/lprf

Applications

Audio	www.ti.com/audio
Automotive	www.ti.com/automotive
Broadband	www.ti.com/broadband
Digital Control	www.ti.com/digitalcontrol
Medical	www.ti.com/medical
Military	www.ti.com/military
Optical Networking	www.ti.com/opticalnetwork
Security	www.ti.com/security
Telephony	www.ti.com/telephony
Video & Imaging	www.ti.com/video
Wireless	www.ti.com/wireless

Mailing Address: Texas Instruments, Post Office Box 655303, Dallas, Texas 75265
Copyright © 2008, Texas Instruments Incorporated

Looking for pricing, stock, or lifecycle information?

Click below to explore more details on WIN SOURCE:

 [View SN65LVDM31DR on WIN SOURCE](#)

 [Texas Instruments](#) Information

Optimize Your Supply Chain with WIN SOURCE Solutions

-  Global Sourcing Solution
-  Obsolete Management
-  Cost Control Management
-  Shortage Management
-  Alternative Solution
-  Excess Inventory Management