

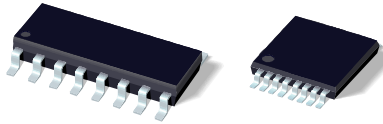

**THE DATASHEET OF
SN65LVCP22PW**





2x2 LVDS CROSSPOINT SWITCH

FEATURES

- High Speed (>1000 Mbps) Upgrade for DS90CP22 2x2 LVDS Crosspoint Switch
- LVPECL Crosspoint Switch Available in SN65LVCP23
- Low-Jitter Fully Differential Data Path
- 50 ps (Typ), of Peak-to-Peak Jitter With PRBS = $2^{23}-1$ Pattern
- Less Than 200 mW (Typ), 300 mW (Max) Total Power Dissipation
- Output (Channel-to-Channel) Skew Is 10 ps (Typ), 50 ps (Max)
- Configurable as 2:1 Mux, 1:2 Demux, Repeater or 1:2 Signal Splitter
- Inputs Accept LVDS, LVPECL, and CML Signals
- Fast Switch Time of 1.7 ns (Typ)
- Fast Propagation Delay of 0.65 ns (Typ)
- 16 Lead SOIC and TSSOP Packages
- Inter-Operates With TIA/EIA-644-A LVDS Standard
- Operating Temperature: -40°C to 85°C

APPLICATIONS

- Base Stations
- Add/Drop Muxes
- Protection Switching for Serial Backplanes
- Network Switches/Routers
- Optical Networking Line Cards/Switches
- Clock Distribution

DESCRIPTION

The SN65LVCP22 is a 2x2 crosspoint switch providing greater than 1000 Mbps operation for each path. The dual channels incorporate wide common-mode (0 V to 4 V) receivers, allowing for the receipt of LVDS, LVPECL, and CML signals. The dual outputs are LVDS drivers to provide low-power, low-EMI, high-speed operation. The SN65LVCP22 provides a single device supporting 2:2 buffering (repeating), 1:2 splitting, 2:1 multiplexing, 2x2 switching, and LVPECL/CML to LVDS level translation on each channel. The flexible operation of the SN65LVCP22 provides a single device to support the redundant serial bus transmission needs (working and protection switching cards) of fault-tolerant switch systems found in optical networking, wireless infrastructure, and data communications systems. TI offers additional gigabit repeater/ translator and crosspoint products in the SN65LVDS100 and SN65LVDS122.

The SN65LVCP22 uses a fully differential data path to ensure low-noise generation, fast switching times, low pulse width distortion, and low jitter. Output channel-to-channel skew is less than 10 ps (typ) and 50 ps (max) to ensure accurate alignment of outputs in all applications. Both SOIC and TSSOP package options are available to allow easy upgrade for existing solutions, and board area savings where space is critical.

OUTPUTS OPERATING SIMULTANEOUSLY

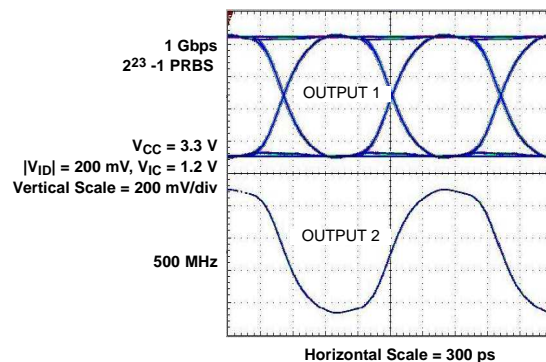

Please be aware that an important notice concerning availability, standard warranty, and use in critical applications of Texas Instruments semiconductor products and disclaimers thereto appears at the end of this data sheet.



These devices have limited built-in ESD protection. The leads should be shorted together or the device placed in conductive foam during storage or handling to prevent electrostatic damage to the MOS gates.

ORDERING INFORMATION

PACKAGE DESIGNATOR	PART NUMBER ⁽¹⁾	SYMBOLIZATION
SOIC	SN65LVCP22D	LVCP22
TSSOP	SN65LVCP22PW	LVCP22

(1) Add the suffix R for taped and reeled carrier

PACKAGE DISSIPATION RATINGS

PACKAGE	CIRCUIT BOARD MODEL	T _A ≤ 25°C POWER RATING	DERATING FACTOR ⁽¹⁾ ABOVE T _A = 25°C	T _A = 85°C POWER RATING
SOIC (D)	High-K ⁽²⁾	1361 mW	13.9 mW/°C	544 mW
TSSOP (PW)	High-K ⁽²⁾	1074 mW	10.7 mW/°C	430 mW

(1) This is the inverse of the junction-to-ambient thermal resistance when board-mounted and with no air flow.
 (2) In accordance with the High-K thermal metric definitions of EIA/JESD51-7.

THERMAL CHARACTERISTICS

PARAMETER		TEST CONDITIONS		VALUE	UNITS
θ _{JB}	Junction-to-board thermal resistance	D		11.2	°C/W
		PW		18.4	
θ _{JC}	Junction-to-case thermal resistance	D		23.7	°C/W
		PW		16.0	
P _D	Device power dissipation	Typical	V _{CC} = 3.3 V, T _A = 25°C, 1 Gbps	198	mW
		Maximum	V _{CC} = 3.6 V, T _A = 85°C, 1 Gbps	313	

FUNCTION TABLE

SEL0	SEL1	OUT0	OUT1	FUNCTION
0	0	IN0	IN0	1:2 Splitter
0	1	IN0	IN1	Repeater
1	0	IN1	IN0	Switch
1	1	IN1	IN1	1:2 Splitter

FUNCTIONAL BLOCK DIAGRAM

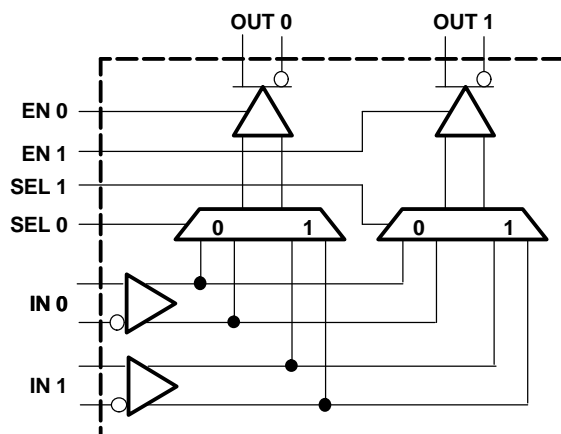

EQUIVALENT INPUT AND OUTPUT SCHEMATIC DIAGRAMS

INPUTS

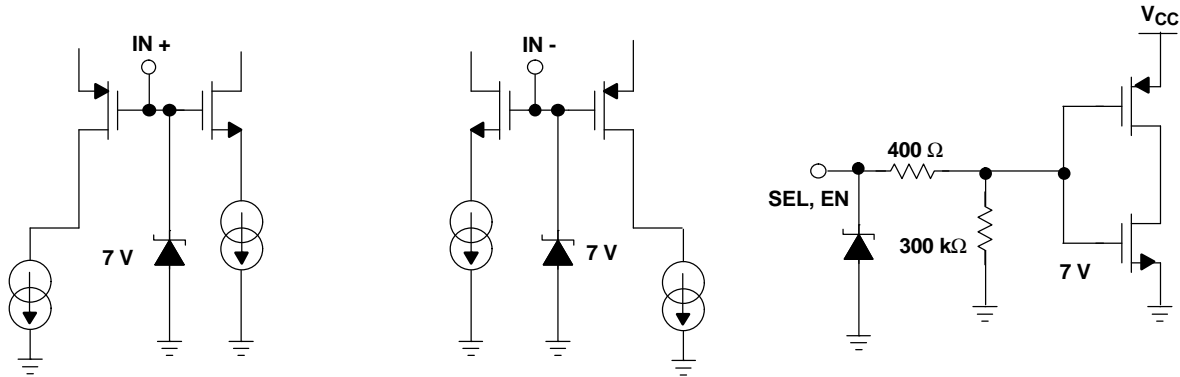

OUTPUTS

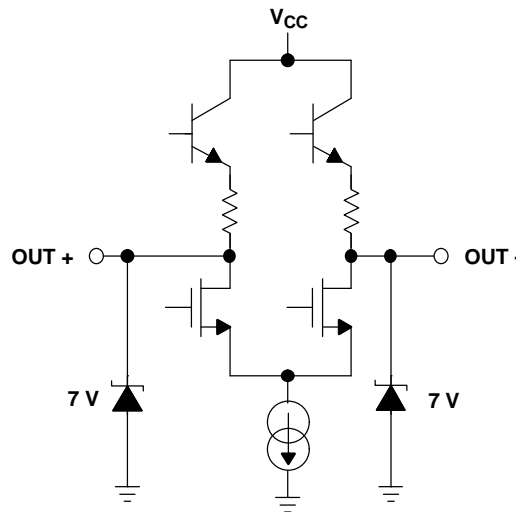

ABSOLUTE MAXIMUM RATINGS

over operating free-air temperature range unless otherwise noted⁽¹⁾

		UNITS	
Supply voltage ⁽²⁾ range, V_{CC}		-0.5 V to 4 V	
CMOS/TTL input voltage (ENO, EN1, SEL0, SEL1)		-0.5 V to 4 V	
LVDS receiver input voltage (IN+, IN-)		-0.7 V to 4.3 V	
LVDS driver output voltage (OUT+, OUT-)		-0.5 V to 4 V	
LVDS output short circuit current		Continuous	
Storage temperature range		-65°C to 125°C	
Lead temperature 1,6 mm (1/16 inch) from case for 10 seconds		235°C	
Continuous power dissipation		See Dissipation Rating Table	
Electrostatic discharge	Human body model ⁽³⁾	All pins	±5 kV
	Charged-device mode ⁽⁴⁾	All pins	±500 V

- (1) Stresses beyond those listed under *absolute maximum ratings* may cause permanent damage to the device. These are stress ratings only, and functional operation of the device at these or any other conditions beyond those indicated under *recommended operating conditions* is not implied. Exposure to absolute-maximum-rated conditions for extended periods may affect device reliability.
- (2) All voltage values, except differential I/O bus voltages, are with respect to network ground terminals.
- (3) Tested in accordance with JEDEC Standard 22, Test Method A114-A.
- (4) Tested in accordance with JEDEC Standard 22, Test Method C101.

RECOMMENDED OPERATING CONDITIONS

	MIN	NOM	MAX	UNIT
Supply voltage, V_{CC}	3	3.3	3.6	V
Receiver input voltage	0		4	V
Junction temperature			125	°C
Operating free-air temperature, $T_A^{(1)}$	-40		85	°C
Magnitude of differential input voltage $ V_{ID} $	0.1		3	V

(1) Maximum free-air temperature operation is allowed as long as the device maximum junction temperature is not exceeded.

INPUT ELECTRICAL CHARACTERISTICS

over recommended operating conditions unless otherwise noted

PARAMETER	TEST CONDITIONS	MIN	TYP ⁽¹⁾	MAX	UNIT
CMOS/TTL DC SPECIFICATIONS (EN0, EN1, SEL0, SEL1)					
V_{IH} High-level input voltage		2		V_{CC}	V
V_{IL} Low-level input voltage		GND		0.8	V
I_{IH} High-level input current	$V_{IN} = 3.6\text{ V or }2.0\text{ V}, V_{CC} = 3.6\text{ V}$		±3	±20	µA
I_{IL} Low-level input current	$V_{IN} = 0.0\text{ V or }0.8\text{ V}, V_{CC} = 3.6\text{ V}$		±1	±10	µA
V_{CL} Input clamp voltage	$I_{CL} = -18\text{ mA}$		-0.8	-1.5	V
LVDS OUTPUT SPECIFICATIONS (OUT0, OUT1)					
$ V_{OD} $ Differential output voltage	$R_L = 75\ \Omega$, See Figure 2	270	365	475	mV
	$R_L = 75\ \Omega, V_{CC} = 3.3\text{ V}, T_A = 25^\circ\text{C}$, See Figure 2	285	365	440	
$\Delta V_{OD} $ Change in differential output voltage magnitude between logic states	$V_{ID} = \pm 100\text{ mV}$, See Figure 2	-25		25	mV
V_{OS} Steady-state offset voltage	See Figure 3	1	1.2	1.45	V
ΔV_{OS} Change in steady-state offset voltage between logic states	See Figure 3	-25		25	mV
$V_{OC(PP)}$ Peak-to-peak common-mode output voltage	See Figure 3		50	150	mV
I_{OZ} High-impedance output current	$V_{OUT} = \text{GND or } V_{CC}$			±10	µA
I_{OFF} Power-off leakage current	$V_{CC} = 0\text{ V}, 1.5\text{ V}; V_{OUT} = 3.6\text{ V or GND}$			±10	µA
I_{OS} Output short-circuit current	V_{OUT+} or $V_{OUT-} = 0\text{ V}$			-24	mA
I_{OSB} Both outputs short-circuit current	V_{OUT+} and $V_{OUT-} = 0\text{ V}$	-12		12	mA
C_O Differential output capacitance	$V_I = 0.4 \sin(4E6\pi t) + 0.5\text{ V}$		3		pF
LVDS RECEIVER DC SPECIFICATIONS (IN0, IN1)					
V_{TH} Positive-going differential input voltage threshold	See Figure 1 and Table 1			100	mV
V_{TL} Negative-going differential input voltage threshold	See Figure 1 and Table 1	-100			mV
$V_{ID(HYS)}$ Differential input voltage hysteresis			25		mV
V_{CMR} Common-mode voltage range	$V_{ID} = 100\text{ mV}, V_{CC} = 3.0\text{ V to }3.6\text{ V}$	0.05		3.95	V
I_{IN} Input current	$V_{IN} = 4\text{ V}, V_{CC} = 3.6\text{ V or }0.0$		±1	±10	µA
	$V_{IN} = 0\text{ V}, V_{CC} = 3.6\text{ V or }0.0$		±1	±10	
C_{IN} Differential input capacitance	$V_I = 0.4 \sin(4E6\pi t) + 0.5\text{ V}$		3		pF
SUPPLY CURRENT					
I_{CCD} Total supply current	$R_L = 75\ \Omega, C_L = 5\text{ pF}, 500\text{ MHz (1000 Mbps)}, EN0=EN1=High$		60	87	mA
I_{CCZ} 3-state supply current	$EN0 = EN1 = Low$		25	35	mA

(1) All typical values are at 25°C and with a 3.3-V supply.

SWITCHING CHARACTERISTICS

over recommended operating conditions unless otherwise noted

parameter	TEST CONDITIONS	MIN	TYP	MAX	UNIT
t_{SET} Input to SEL setup time	See Figure 6	1	0.5		ns
t_{HOLD} Input to SEL hold time	See Figure 6	1.1	0.5		ns
t_{SWITCH} SEL to switched output	See Figure 6		1.7	2.5	ns
t_{PHZ} Disable time, high-level-to-high-impedance	See Figure 5		2	4	ns
t_{PLZ} Disable time, low-level-to-high-impedance	See Figure 5		2	4	ns
t_{PZH} Enable time, high-impedance -to-high-level output	See Figure 5		2	4	ns
t_{PZL} Enable time, high-impedance-to-low-level output	See Figure 5		2	4	ns
t_{LHT} Differential output signal rise time (20%-80%) ⁽¹⁾	$C_L = 5$ pF, See Figure 4	150	280	450	ps
t_{HLT} Differential output signal fall time (20%-80%) ⁽¹⁾	$C_L = 5$ pF, See Figure 4	150	280	450	ps
t_{JIT} Added peak-to-peak jitter	$V_{ID} = 200$ mV, 50% duty cycle, $V_{CM} = 1.2$ V, 500 MHz, $C_L = 5$ pF		20	40	ps
	$V_{ID} = 200$ mV, PRBS = 2 ²³ -1 data pattern, $V_{CM} = 1.2$ V at 1000 Mbps, $C_L = 5$ pF		50	105	ps
t_{Jrms} Added random jitter (rms)	$V_{ID} = 200$ mV, 50% duty cycle, $V_{CM} = 1.2$ V at 500 MHz, $C_L = 5$ pF		1.1	1.8	ps _{RMS}
t_{PLHD} Propagation delay time, low-to-high-level output ⁽¹⁾		400	650	1000	ps
t_{PHLD} Propagation delay time, high-to-low-level output ⁽¹⁾		400	650	1000	ps
t_{skew} Pulse skew ($ t_{PLHD} - t_{PHLD} $) ⁽²⁾	$C_L = 5$ pF, See Figure 4		20	100	ps
t_{CCS} Output channel-to-channel skew, splitter mode	$C_L = 5$ pF, See Figure 4		10	50	ps
f_{MAX} Maximum operating frequency ⁽³⁾		1			GHz

(1) Input: $V_{IC} = 1.2$ V, $V_{ID} = 200$ mV, 50% duty cycle, 1 MHz, $t_r/t_f = 500$ ps

(2) t_{skew} is the magnitude of the time difference between the t_{PLHD} and t_{PHLD} of any output of a single device.

(3) Signal generator conditions: 50% duty cycle, t_r or $t_f \leq 100$ ps (10% to 90%), transmitter output criteria: duty cycle = 45% to 55% $V_{OD} \geq 300$ mV.

PIN ASSIGNMENTS

D or PW PACKAGE
(TOP VIEW)

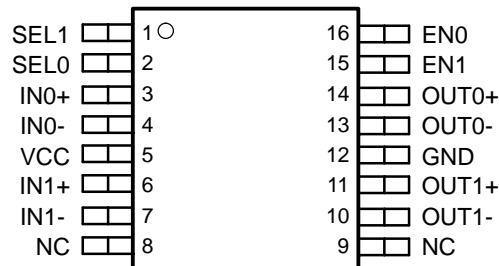

NC - No internal connection

PARAMETER MEASUREMENT INFORMATION

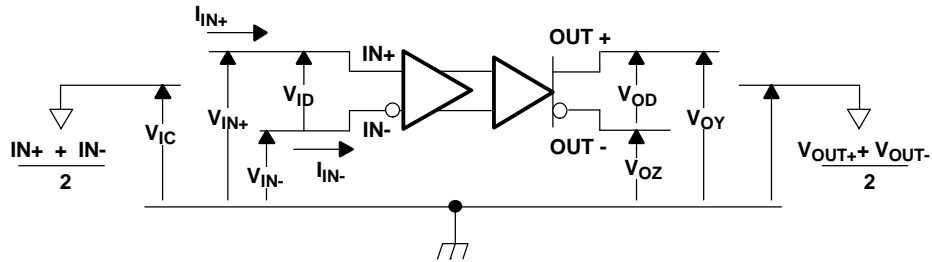

Figure 1. Voltage and Current Definitions

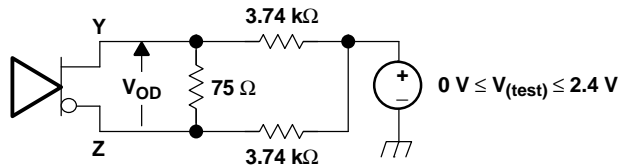
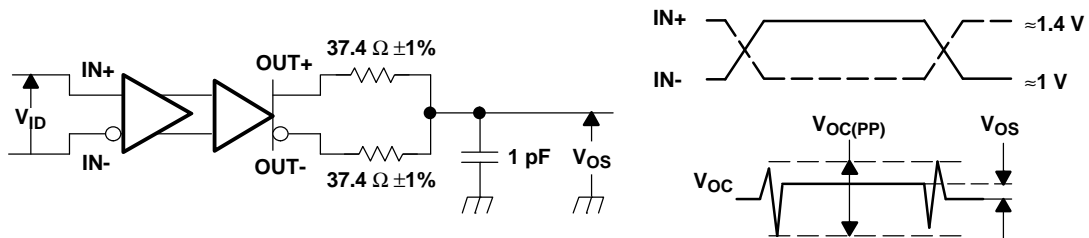

Figure 2. Differential Output Voltage (V_{OD}) Test Circuit



NOTE: All input pulses are supplied by a generator having the following characteristics: t_r or $t_f \leq 1$ ns, pulse-repetition rate (PRR) = 0.5 Mpps, pulse width = 500 ± 10 ns; $R_L = 100 \Omega$; C_L includes instrumentation and fixture capacitance within 0,06 mm of the D.U.T.; the measurement of $V_{OC(PP)}$ is made on test equipment with a -3 dB bandwidth of at least 300 MHz.

Figure 3. Test Circuit and Definitions for the Driver Common-Mode Output Voltage

PARAMETER MEASUREMENT INFORMATION (continued)

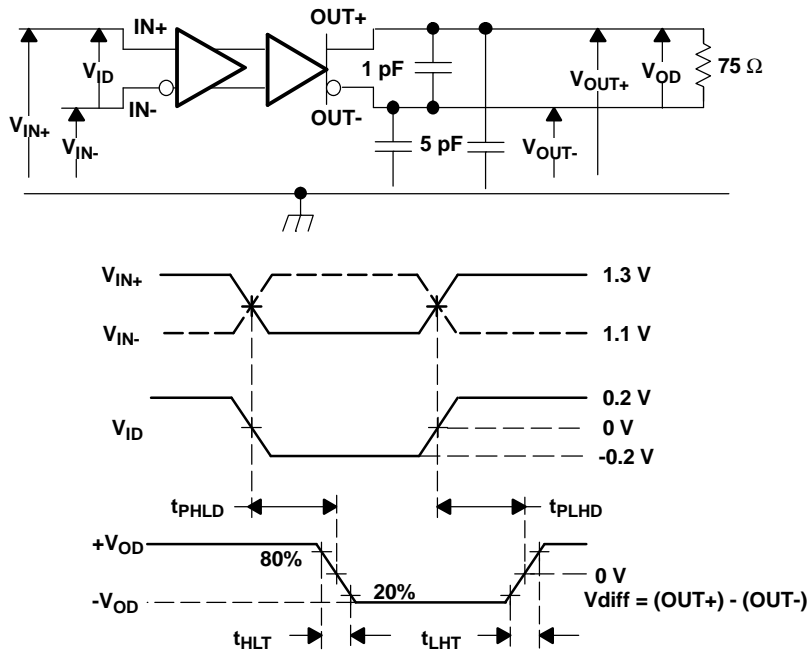

NOTE: All input pulses are supplied by a generator having the following characteristics: t_r or $t_f \leq .25$ ns, pulse-repetition rate (PRR) = 0.5 Mpps, pulse width = 500 ± 10 ns. C_L includes instrumentation and fixture capacitance within 0,06 mm of the D.U.T.

Figure 4. Timing Test Circuit and Waveforms

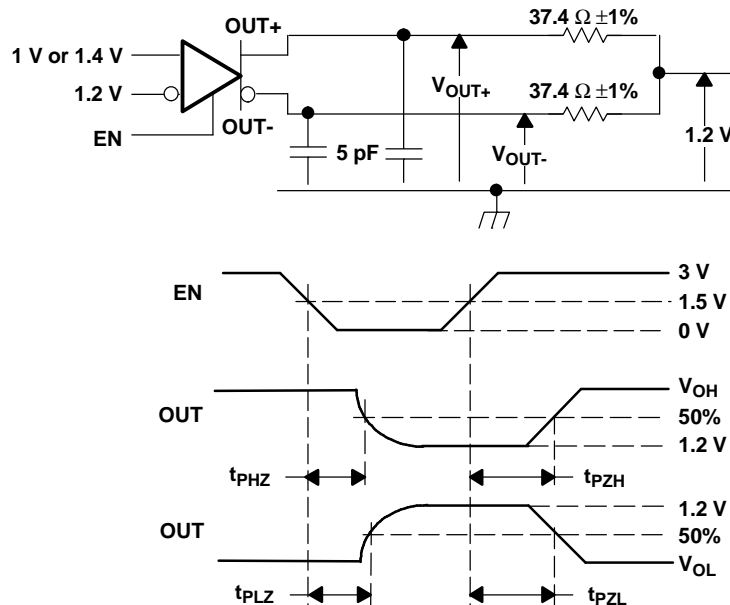

NOTE: All input pulses are supplied by a generator having the following characteristics: t_r or $t_f \leq 1$ ns, pulse-repetition rate (PRR) = 0.5 Mpps, pulse width = 500 ± 10 ns. C_L includes instrumentation and fixture capacitance within 0,06 mm of the D.U.T.

Figure 5. Enable and Disable Time Circuit and Definitions

Table 1. Receiver Input Voltage Threshold Test

APPLIED VOLTAGES		RESULTING DIFFERENTIAL INPUT VOLTAGE	RESULTING COMMON- MODE INPUT VOLTAGE	OUTPUT ⁽¹⁾
V_{IA}	V_{IB}	V_{ID}	V_{IC}	
1.25 V	1.15 V	100 mV	1.2 V	H
1.15 V	1.25 V	–100 mV	1.2 V	L
4.0 V	3.9 V	100 mV	3.95 V	H
3.9 V	4.0 V	–100 mV	3.95 V	L
0.1 V	0.0 V	100 mV	0.05 V	H
0.0 V	0.1 V	–100 mV	0.05 V	L
1.7 V	0.7 V	1000 mV	1.2 V	H
0.7 V	1.7 V	–1000 mV	1.2 V	L
4.0 V	3.0 V	1000 mV	3.5 V	H
3.0 V	4.0 V	–1000 mV	3.5 V	L
1.0 V	0.0 V	1000 mV	0.5 V	H
0.0 V	1.0 V	–1000 mV	0.5 V	L

(1) H = high level, L = low level

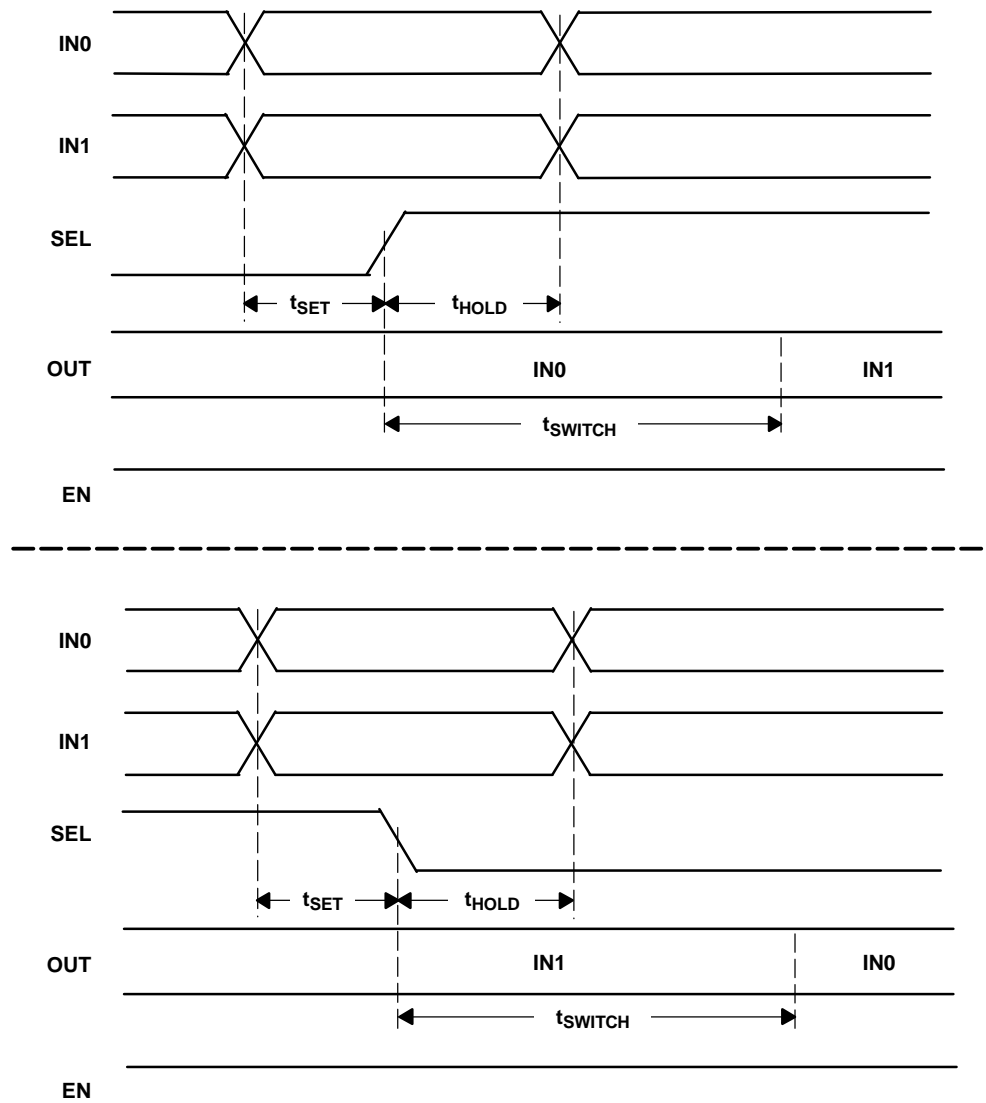

NOTE: t_{SET} and t_{HOLD} times specify that data must be in a stable state before and after mux control switches.

Figure 6. Input to Select for Both Rising and Falling Edge Setup and Hold Times

TYPICAL CHARACTERISTICS

DIFFERENTIAL OUTPUT VOLTAGE
VS
RESISTIVE LOAD

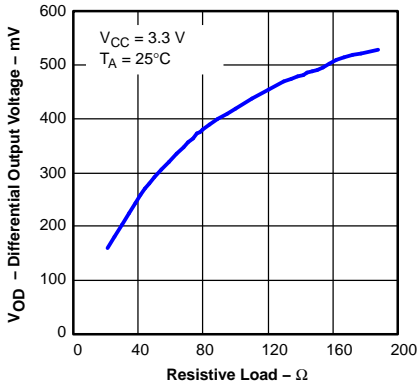

Figure 7.

SUPPLY CURRENT
VS
FREQUENCY

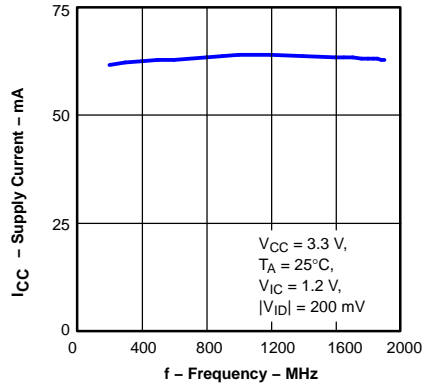

Figure 8.

PROPAGATION DELAY TIME
VS
FREE-AIR TEMPERATURE

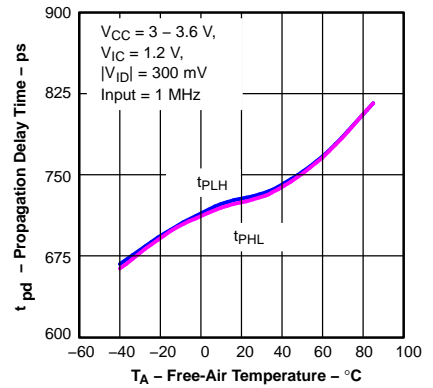

Figure 9.

PEAK-TO-PEAK JITTER
VS
FREQUENCY

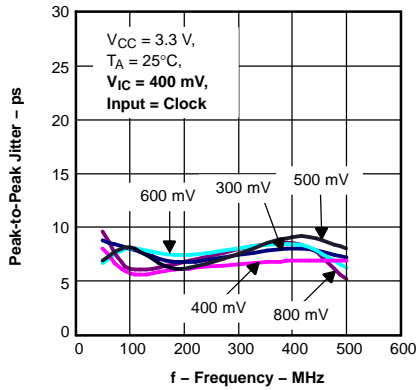

Figure 10.

PEAK-TO-PEAK JITTER
VS
DATA RATE

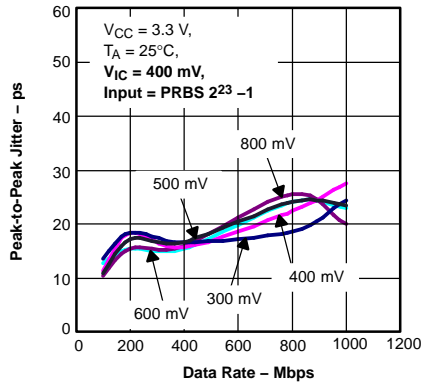

Figure 11.

PEAK-TO-PEAK JITTER
VS
FREQUENCY

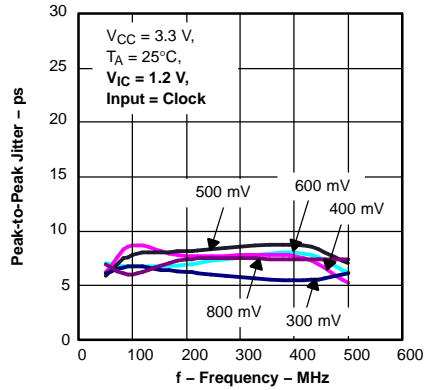

Figure 12.

PEAK-TO-PEAK JITTER
VS
DATA RATE

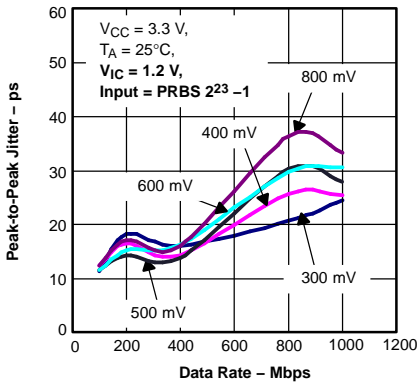

Figure 13.

PEAK-TO-PEAK JITTER
VS
FREQUENCY

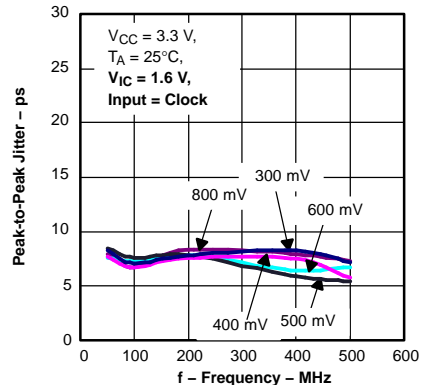

Figure 14.

PEAK-TO-PEAK JITTER
VS
DATA RATE

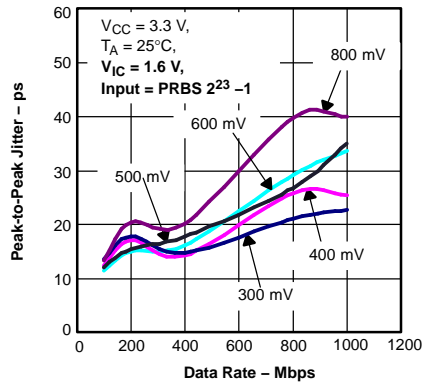

Figure 15.

TYPICAL CHARACTERISTICS (continued)

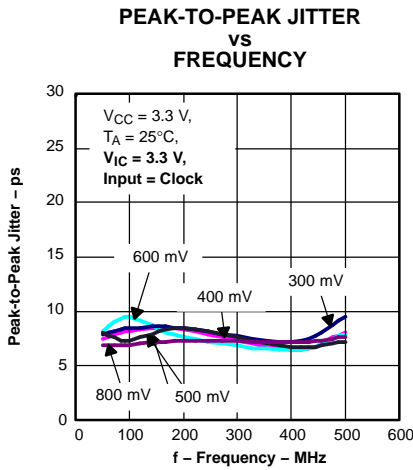

Figure 16.

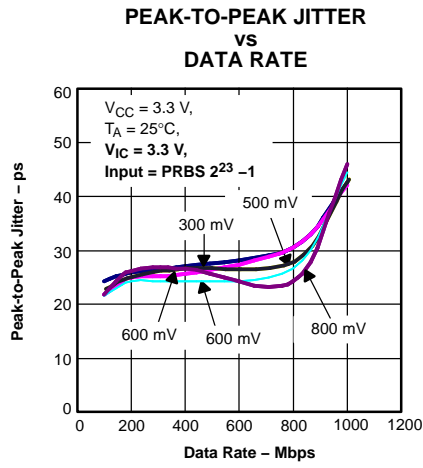

Figure 17.

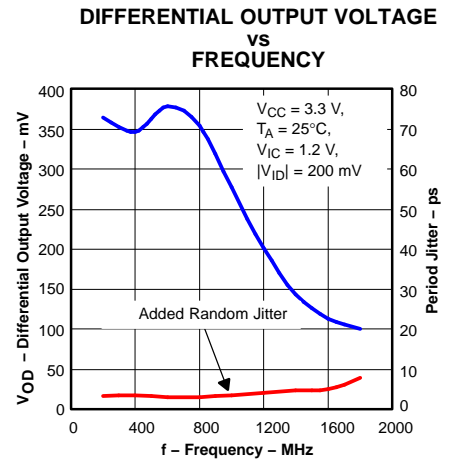

Figure 18.

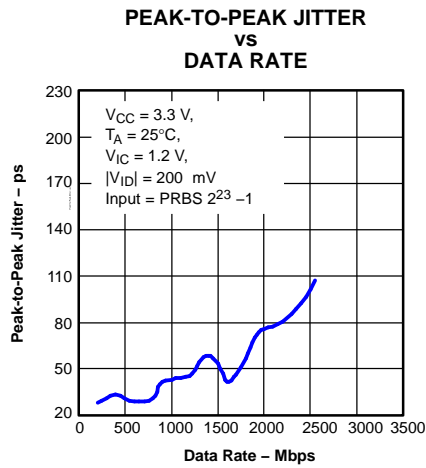

Figure 19.

APPLICATION INFORMATION

TYPICAL APPLICATION CIRCUITS (ECL, PECL, LVDS, etc.)

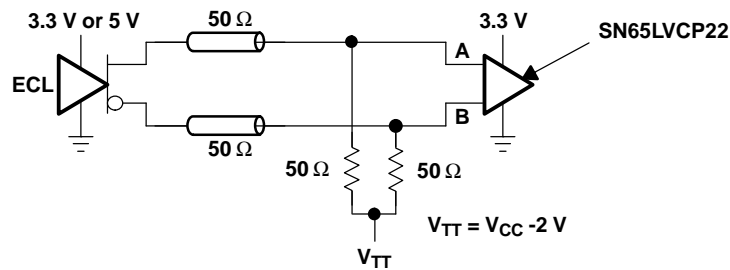

Figure 20. Low-Voltage Positive Emitter-Coupled Logic (LVPECL)

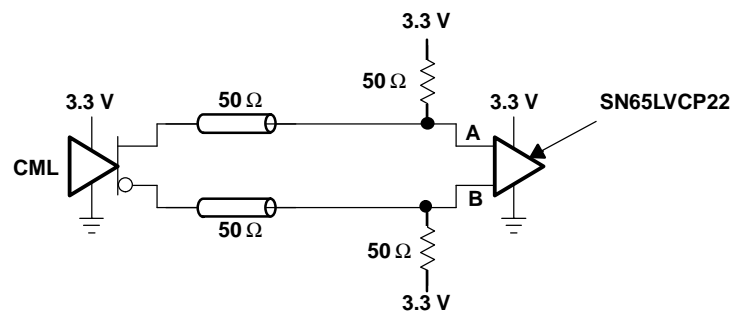

Figure 21. Current-Mode Logic (CML)

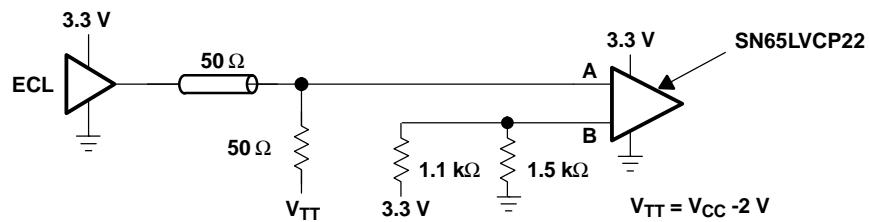

Figure 22. Single-Ended (LVPECL)

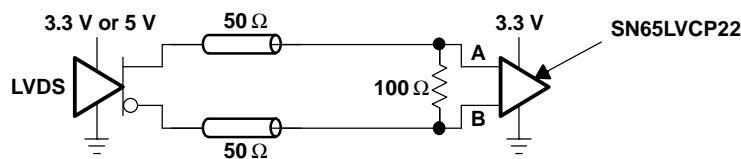

Figure 23. Low-Voltage Differential Signaling (LVDS)

APPLICATION INFORMATION (continued)

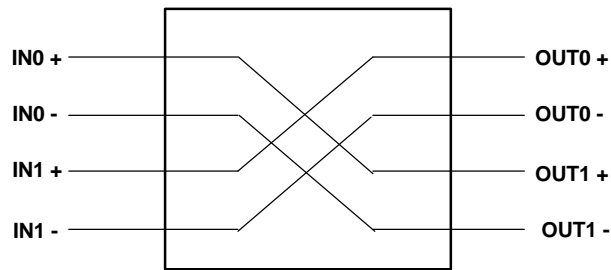

Figure 24. 2 x 2 Crosspoint

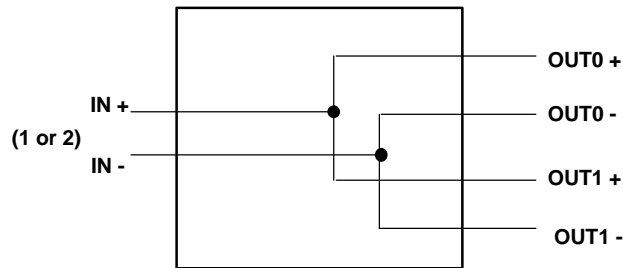

Figure 25. 1:2 Splitter



Figure 26. Dual Repeater

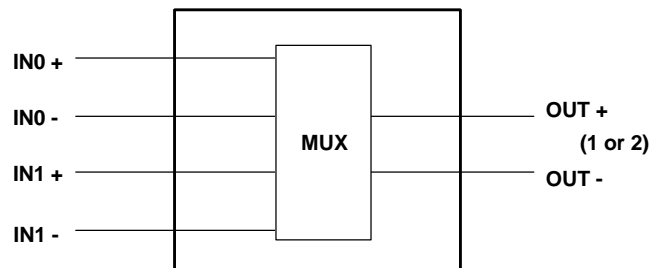

Figure 27. 2:1 MUX

PACKAGING INFORMATION

Orderable Device	Status (1)	Package Type	Package Drawing	Pins	Package Qty	Eco Plan (2)	Lead/Ball Finish (6)	MSL Peak Temp (3)	Op Temp (°C)	Device Marking (4/5)	Samples
SN65LVCP22D	ACTIVE	SOIC	D	16	40	Green (RoHS & no Sb/Br)	CU NIPDAU	Level-1-260C-UNLIM	-40 to 85	LVCP22	Samples
SN65LVCP22DG4	ACTIVE	SOIC	D	16	40	Green (RoHS & no Sb/Br)	CU NIPDAU	Level-1-260C-UNLIM	-40 to 85	LVCP22	Samples
SN65LVCP22DR	ACTIVE	SOIC	D	16	2500	Green (RoHS & no Sb/Br)	CU NIPDAU	Level-1-260C-UNLIM	-40 to 85	LVCP22	Samples
SN65LVCP22PW	ACTIVE	TSSOP	PW	16	90	Green (RoHS & no Sb/Br)	CU NIPDAU	Level-1-260C-UNLIM	-40 to 85	LVCP22	Samples
SN65LVCP22PWR	ACTIVE	TSSOP	PW	16	2000	Green (RoHS & no Sb/Br)	CU NIPDAU	Level-1-260C-UNLIM	-40 to 85	LVCP22	Samples

(1) The marketing status values are defined as follows:

ACTIVE: Product device recommended for new designs.

LIFEBUY: TI has announced that the device will be discontinued, and a lifetime-buy period is in effect.

NRND: Not recommended for new designs. Device is in production to support existing customers, but TI does not recommend using this part in a new design.

PREVIEW: Device has been announced but is not in production. Samples may or may not be available.

OBSOLETE: TI has discontinued the production of the device.

(2) **RoHS:** TI defines "RoHS" to mean semiconductor products that are compliant with the current EU RoHS requirements for all 10 RoHS substances, including the requirement that RoHS substance do not exceed 0.1% by weight in homogeneous materials. Where designed to be soldered at high temperatures, "RoHS" products are suitable for use in specified lead-free processes. TI may reference these types of products as "Pb-Free".

RoHS Exempt: TI defines "RoHS Exempt" to mean products that contain lead but are compliant with EU RoHS pursuant to a specific EU RoHS exemption.

Green: TI defines "Green" to mean the content of Chlorine (Cl) and Bromine (Br) based flame retardants meet JS709B low halogen requirements of <=1000ppm threshold. Antimony trioxide based flame retardants must also meet the <=1000ppm threshold requirement.

(3) MSL, Peak Temp. - The Moisture Sensitivity Level rating according to the JEDEC industry standard classifications, and peak solder temperature.

(4) There may be additional marking, which relates to the logo, the lot trace code information, or the environmental category on the device.

(5) Multiple Device Markings will be inside parentheses. Only one Device Marking contained in parentheses and separated by a "-" will appear on a device. If a line is indented then it is a continuation of the previous line and the two combined represent the entire Device Marking for that device.

(6) Lead/Ball Finish - Orderable Devices may have multiple material finish options. Finish options are separated by a vertical ruled line. Lead/Ball Finish values may wrap to two lines if the finish value exceeds the maximum column width.

Important Information and Disclaimer: The information provided on this page represents TI's knowledge and belief as of the date that it is provided. TI bases its knowledge and belief on information provided by third parties, and makes no representation or warranty as to the accuracy of such information. Efforts are underway to better integrate information from third parties. TI has taken and continues to take reasonable steps to provide representative and accurate information but may not have conducted destructive testing or chemical analysis on incoming materials and chemicals. TI and TI suppliers consider certain information to be proprietary, and thus CAS numbers and other limited information may not be available for release.

In no event shall TI's liability arising out of such information exceed the total purchase price of the TI part(s) at issue in this document sold by TI to Customer on an annual basis.

TAPE AND REEL INFORMATION



QUADRANT ASSIGNMENTS FOR PIN 1 ORIENTATION IN TAPE



*All dimensions are nominal

Device	Package Type	Package Drawing	Pins	SPQ	Reel Diameter (mm)	Reel Width W1 (mm)	A0 (mm)	B0 (mm)	K0 (mm)	P1 (mm)	W (mm)	Pin1 Quadrant
SN65LVCP22DR	SOIC	D	16	2500	330.0	16.4	6.5	10.3	2.1	8.0	16.0	Q1
SN65LVCP22PWR	TSSOP	PW	16	2000	330.0	12.4	6.9	5.6	1.6	8.0	12.0	Q1

TAPE AND REEL BOX DIMENSIONS

*All dimensions are nominal

Device	Package Type	Package Drawing	Pins	SPQ	Length (mm)	Width (mm)	Height (mm)
SN65LVCP22DR	SOIC	D	16	2500	350.0	350.0	43.0
SN65LVCP22PWR	TSSOP	PW	16	2000	350.0	350.0	43.0

D (R-PDSO-G16)

PLASTIC SMALL OUTLINE



- NOTES:
- A. All linear dimensions are in inches (millimeters).
 - B. This drawing is subject to change without notice.
 - C. Body length does not include mold flash, protrusions, or gate burrs. Mold flash, protrusions, or gate burrs shall not exceed 0.006 (0,15) each side.
 - D. Body width does not include interlead flash. Interlead flash shall not exceed 0.017 (0,43) each side.
 - E. Reference JEDEC MS-012 variation AC.

D (R-PDSO-G16)

PLASTIC SMALL OUTLINE

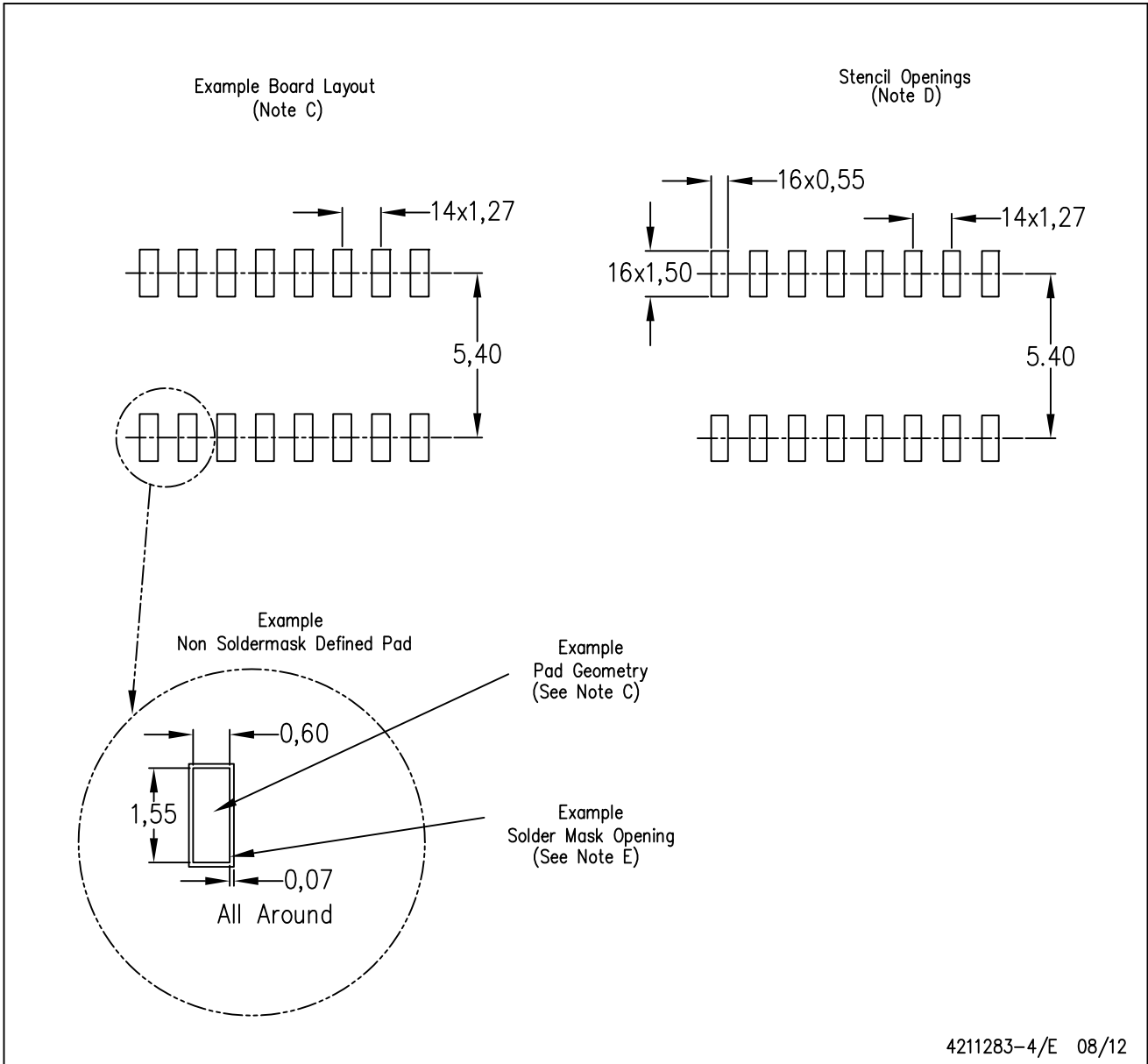

- NOTES:
- All linear dimensions are in millimeters.
 - This drawing is subject to change without notice.
 - Publication IPC-7351 is recommended for alternate designs.
 - Laser cutting apertures with trapezoidal walls and also rounding corners will offer better paste release. Customers should contact their board assembly site for stencil design recommendations. Refer to IPC-7525 for other stencil recommendations.
 - Customers should contact their board fabrication site for solder mask tolerances between and around signal pads.



4220204/A 02/2017

NOTES:

1. All linear dimensions are in millimeters. Any dimensions in parenthesis are for reference only. Dimensioning and tolerancing per ASME Y14.5M.
2. This drawing is subject to change without notice.
3. This dimension does not include mold flash, protrusions, or gate burrs. Mold flash, protrusions, or gate burrs shall not exceed 0.15 mm per side.
4. This dimension does not include interlead flash. Interlead flash shall not exceed 0.25 mm per side.
5. Reference JEDEC registration MO-153.

EXAMPLE BOARD LAYOUT

PW0016A

TSSOP - 1.2 mm max height

SMALL OUTLINE PACKAGE



LAND PATTERN EXAMPLE
EXPOSED METAL SHOWN
SCALE: 10X



SOLDER MASK DETAILS

4220204/A 02/2017

NOTES: (continued)

- 6. Publication IPC-7351 may have alternate designs.
- 7. Solder mask tolerances between and around signal pads can vary based on board fabrication site.

EXAMPLE STENCIL DESIGN

PW0016A

TSSOP - 1.2 mm max height

SMALL OUTLINE PACKAGE



SOLDER PASTE EXAMPLE
BASED ON 0.125 mm THICK STENCIL
SCALE: 10X

4220204/A 02/2017

NOTES: (continued)

8. Laser cutting apertures with trapezoidal walls and rounded corners may offer better paste release. IPC-7525 may have alternate design recommendations.
9. Board assembly site may have different recommendations for stencil design.

IMPORTANT NOTICE AND DISCLAIMER

TI PROVIDES TECHNICAL AND RELIABILITY DATA (INCLUDING DATASHEETS), DESIGN RESOURCES (INCLUDING REFERENCE DESIGNS), APPLICATION OR OTHER DESIGN ADVICE, WEB TOOLS, SAFETY INFORMATION, AND OTHER RESOURCES "AS IS" AND WITH ALL FAULTS, AND DISCLAIMS ALL WARRANTIES, EXPRESS AND IMPLIED, INCLUDING WITHOUT LIMITATION ANY IMPLIED WARRANTIES OF MERCHANTABILITY, FITNESS FOR A PARTICULAR PURPOSE OR NON-INFRINGEMENT OF THIRD PARTY INTELLECTUAL PROPERTY RIGHTS.

These resources are intended for skilled developers designing with TI products. You are solely responsible for (1) selecting the appropriate TI products for your application, (2) designing, validating and testing your application, and (3) ensuring your application meets applicable standards, and any other safety, security, or other requirements. These resources are subject to change without notice. TI grants you permission to use these resources only for development of an application that uses the TI products described in the resource. Other reproduction and display of these resources is prohibited. No license is granted to any other TI intellectual property right or to any third party intellectual property right. TI disclaims responsibility for, and you will fully indemnify TI and its representatives against, any claims, damages, costs, losses, and liabilities arising out of your use of these resources.

TI's products are provided subject to TI's Terms of Sale (www.ti.com/legal/termsofsale.html) or other applicable terms available either on ti.com or provided in conjunction with such TI products. TI's provision of these resources does not expand or otherwise alter TI's applicable warranties or warranty disclaimers for TI products.

Mailing Address: Texas Instruments, Post Office Box 655303, Dallas, Texas 75265
Copyright © 2019, Texas Instruments Incorporated

Looking for pricing, stock, or lifecycle information?

Click below to explore more details on WIN SOURCE:

 [View SN65LVCP22PW on WIN SOURCE](#)

 [Texas Instruments](#) Information

Optimize Your Supply Chain with WIN SOURCE Solutions

-  Global Sourcing Solution
-  Obsolete Management
-  Cost Control Management
-  Shortage Management
-  Alternative Solution
-  Excess Inventory Management